

Symantec NetBackup™ for NDMP Administrator's Guide

UNIX, Windows, and Linux

Release 7.5



Symantec NetBackup™ for NDMP Administrator's Guide

The software described in this book is furnished under a license agreement and may be used only in accordance with the terms of the agreement.

Documentation version: 7.5

Legal Notice

Copyright © 2012 Symantec Corporation. All rights reserved.

Symantec and the Symantec Logo and NetBackup are trademarks or registered trademarks of Symantec Corporation or its affiliates in the U.S. and other countries. Other names may be trademarks of their respective owners. are trademarks or registered trademarks of Symantec Corporation or its affiliates in the U.S. and other countries. Other names may be trademarks of their respective owners.

This Symantec product may contain third party software for which Symantec is required to provide attribution to the third party ("Third Party Programs"). Some of the Third Party Programs are available under open source or free software licenses. The License Agreement accompanying the Software does not alter any rights or obligations you may have under those open source or free software licenses. Please see the Third Party Legal Notice Appendix to this Documentation or TPIP ReadMe File accompanying this Symantec product for more information on the Third Party Programs.

The product described in this document is distributed under licenses restricting its use, copying, distribution, and decompilation/reverse engineering. No part of this document may be reproduced in any form by any means without prior written authorization of Symantec Corporation and its licensors, if any.

THE DOCUMENTATION IS PROVIDED "AS IS" AND ALL EXPRESS OR IMPLIED CONDITIONS, REPRESENTATIONS AND WARRANTIES, INCLUDING ANY IMPLIED WARRANTY OF MERCHANTABILITY, FITNESS FOR A PARTICULAR PURPOSE OR NON-INFRINGEMENT, ARE DISCLAIMED, EXCEPT TO THE EXTENT THAT SUCH DISCLAIMERS ARE HELD TO BE LEGALLY INVALID. SYMANTEC CORPORATION SHALL NOT BE LIABLE FOR INCIDENTAL OR CONSEQUENTIAL DAMAGES IN CONNECTION WITH THE FURNISHING, PERFORMANCE, OR USE OF THIS DOCUMENTATION. THE INFORMATION CONTAINED IN THIS DOCUMENTATION IS SUBJECT TO CHANGE WITHOUT NOTICE.

The Licensed Software and Documentation are deemed to be commercial computer software as defined in FAR 12.212 and subject to restricted rights as defined in FAR Section 52.227-19 "Commercial Computer Software - Restricted Rights" and DFARS 227.7202, "Rights in Commercial Computer Software or Commercial Computer Software Documentation", as applicable, and any successor regulations. Any use, modification, reproduction release, performance, display or disclosure of the Licensed Software and Documentation by the U.S. Government shall be solely in accordance with the terms of this Agreement.

Symantec Corporation
350 Ellis Street
Mountain View, CA 94043
<http://www.symantec.com>

Technical Support

Symantec Technical Support maintains support centers globally. Technical Support's primary role is to respond to specific queries about product features and functionality. The Technical Support group also creates content for our online Knowledge Base. The Technical Support group works collaboratively with the other functional areas within Symantec to answer your questions in a timely fashion. For example, the Technical Support group works with Product Engineering and Symantec Security Response to provide alerting services and virus definition updates.

Symantec's support offerings include the following:

- A range of support options that give you the flexibility to select the right amount of service for any size organization
- Telephone and/or Web-based support that provides rapid response and up-to-the-minute information
- Upgrade assurance that delivers software upgrades
- Global support purchased on a regional business hours or 24 hours a day, 7 days a week basis
- Premium service offerings that include Account Management Services

For information about Symantec's support offerings, you can visit our Web site at the following URL:

www.symantec.com/business/support/

All support services will be delivered in accordance with your support agreement and the then-current enterprise technical support policy.

Contacting Technical Support

Customers with a current support agreement may access Technical Support information at the following URL:

www.symantec.com/business/support/

Before contacting Technical Support, make sure you have satisfied the system requirements that are listed in your product documentation. Also, you should be at the computer on which the problem occurred, in case it is necessary to replicate the problem.

When you contact Technical Support, please have the following information available:

- Product release level

- Hardware information
- Available memory, disk space, and NIC information
- Operating system
- Version and patch level
- Network topology
- Router, gateway, and IP address information
- Problem description:
 - Error messages and log files
 - Troubleshooting that was performed before contacting Symantec
 - Recent software configuration changes and network changes

Licensing and registration

If your Symantec product requires registration or a license key, access our technical support Web page at the following URL:

www.symantec.com/business/support/

Customer service

Customer service information is available at the following URL:

www.symantec.com/business/support/

Customer Service is available to assist with non-technical questions, such as the following types of issues:

- Questions regarding product licensing or serialization
- Product registration updates, such as address or name changes
- General product information (features, language availability, local dealers)
- Latest information about product updates and upgrades
- Information about upgrade assurance and support contracts
- Information about the Symantec Buying Programs
- Advice about Symantec's technical support options
- Nontechnical presales questions
- Issues that are related to CD-ROMs, DVDs, or manuals

Support agreement resources

If you want to contact Symantec regarding an existing support agreement, please contact the support agreement administration team for your region as follows:

Asia-Pacific and Japan customercare_apac@symantec.com

Europe, Middle-East, and Africa semea@symantec.com

North America and Latin America supportsolutions@symantec.com

Contents

Technical Support	4
Chapter 1 Introduction to NetBackup for NDMP	11
About NetBackup for NDMP	12
NetBackup for NDMP features	12
NetBackup for NDMP terminology	14
Network Data Management Protocol (NDMP)	17
Types of NDMP backup	18
NDMP local backup	18
NDMP three-way back up	19
Backup to Media Manager storage units (remote NDMP)	20
NDMP policies	21
NetBackup storage units	22
NDMP-type storage units	22
Media Manager storage units	22
About assigning tape drives to different hosts	22
NDMP host	24
NetBackup server	25
NDMP backup process	25
NDMP restore process	27
Direct Access Recovery (DAR)	29
NDMP DirectCopy with VTL	30
NDMP DirectCopy without VTL	32
NDMP DirectCopy notes and limitations	33
NDMP information on the Web	34
Snapshot Client assistance	34
NDMP multiplexing	34
NDMP multiplexing general considerations	35
NDMP IPv6 address data connections	35
NDMP IPv6 general considerations	36
About NDMP support for Replication Director	36
Limitations of NDMP support for Replication Director	36

Chapter 2	Installing NetBackup for NDMP	39
	NetBackup for NDMP installation prerequisites	39
	Installing NetBackup for NDMP on UNIX servers	40
	Installing NetBackup for NDMP on Windows servers	41
	Uninstalling NetBackup for NDMP	41
Chapter 3	Configuring NDMP backup to NDMP-attached devices	43
	About configuring NDMP-attached devices	44
	Authorizing NetBackup access to the NDMP host	44
	About access for three-way backups and remote NDMP	46
	Media and Device Management configuration	46
	Adding a robot directly attached to an NDMP host	46
	Adding a drive	49
	Checking the device configuration	51
	About adding volumes	52
	About verifying NDMP password and robot connection	52
	Adding NDMP storage units	52
	About creating an NDMP policy	53
	Required Attributes tab options for an NDMP policy	54
	Required Schedules tab options for an NDMP policy	54
	Required Clients tab options for an NDMP policy	55
	Required backup selections options for an NDMP policy	55
	About environment variables in the backup selections list	56
	Backup types in a schedule for an NDMP policy	57
	About enabling or disabling DAR	57
	Disabling DAR for file and directory restores	58
	Disabling DAR for directory restores only	59
	Setting up clustering	59
	Post-installation changes	60
	About testing an NDMP configuration	60
Chapter 4	Configuring NDMP backup to NetBackup media servers (remote NDMP)	61
	About remote NDMP	61
	Configuring NDMP backup to Media Manager storage units	62
Chapter 5	Configuring NDMP direct copy	65
	About NDMP DirectCopy	65
	Prerequisites for using NDMP DirectCopy	65

	Configuring NDMP DirectCopy	66
	Using NDMP DirectCopy to duplicate a backup image	67
	Requirements to use NDMP DirectCopy for image duplication	67
	Initiating NDMP DirectCopy with the NetBackup Administration Console	68
Chapter 6	Remote NDMP and disk devices	69
	About remote NDMP and disk devices	69
	Configuring remote NDMP	70
Chapter 7	Using the Shared Storage Option (SSO)	73
	About the Shared Storage Option (SSO)	73
	Setting up SSO overview	74
	Using the NetBackup Device Configuration Wizard	75
Chapter 8	Backup and restore procedures	79
	About NDMP backup	79
	Automatic backup of an NDMP policy	79
	Performing a manual backup of an NDMP policy	79
	Performing a restore from the server	80
Chapter 9	Troubleshooting	83
	Additional troubleshooting information	83
	NDMP operating notes and restrictions	84
	Notes on Direct Access Recovery (DAR)	84
	Types of NetBackup logs	85
	Using NetBackup logs	85
	NetBackup for NDMP troubleshooting suggestions	86
	NDMP backup levels	87
	Troubleshooting media and devices on Windows	88
	Troubleshooting media and devices on UNIX	89
	Troubleshooting NDMP DirectCopy	89
	Troubleshooting Direct Access Recovery (DAR)	89
	About testing a robot	90
	TL8 robot test example for Windows	91
	TLD robot test example for UNIX	91
	TLH robot test example for UNIX	92

Chapter 10	Using scripts	93
	About the NetBackup for NDMP scripts	93
	ndmp_start_notify script (UNIX)	94
	ndmp_start_notify.cmd script (Microsoft Windows)	96
	ndmp_end_notify script (UNIX)	98
	ndmp_end_notify.cmd script (Microsoft Windows)	100
	ndmp_start_path_notify script (UNIX)	102
	ndmp_start_path_notify.cmd script (Microsoft Windows)	105
	ndmp_end_path_notify script (UNIX)	107
	ndmp_end_path_notify.cmd script (Microsoft Windows)	109
	ndmp_moving_path_notify script (UNIX)	111
	ndmp_moving_path_notify.cmd script (Microsoft Windows)	114
Index		117

Introduction to NetBackup for NDMP

This chapter includes the following topics:

- [About NetBackup for NDMP](#)
- [NetBackup for NDMP features](#)
- [NetBackup for NDMP terminology](#)
- [Network Data Management Protocol \(NDMP\)](#)
- [Types of NDMP backup](#)
- [NDMP local backup](#)
- [NDMP three-way back up](#)
- [Backup to Media Manager storage units \(remote NDMP\)](#)
- [NDMP policies](#)
- [NetBackup storage units](#)
- [NDMP-type storage units](#)
- [Media Manager storage units](#)
- [About assigning tape drives to different hosts](#)
- [NDMP host](#)
- [NetBackup server](#)
- [NDMP backup process](#)

- [NDMP restore process](#)
- [Direct Access Recovery \(DAR\)](#)
- [NDMP DirectCopy with VTL](#)
- [NDMP DirectCopy without VTL](#)
- [NDMP DirectCopy notes and limitations](#)
- [NDMP information on the Web](#)
- [Snapshot Client assistance](#)
- [NDMP multiplexing](#)
- [NDMP multiplexing general considerations](#)
- [NDMP IPv6 address data connections](#)
- [NDMP IPv6 general considerations](#)
- [About NDMP support for Replication Director](#)
- [Limitations of NDMP support for Replication Director](#)

About NetBackup for NDMP

NetBackup for NDMP is an optional NetBackup application. It enables NetBackup to use the Network Data Management Protocol (NDMP) to initiate and control backups and restores of Network Attached Storage (NAS) systems.

NetBackup for NDMP features

The following table describes the NetBackup for NDMP features.

Table 1-1 NetBackup for NDMP features

Feature	Description
Support for NDMP protocol	Supports the NDMP protocol versions V2, V3, and V4.
Centralized backup-policy management	Scheduling, catalog management, and other backup tasks are managed from a NetBackup master server. NetBackup for NDMP can be installed on a NetBackup master or media server.

Table 1-1 NetBackup for NDMP features (*continued*)

Feature	Description
Device and media management	NetBackup software provides complete management and control of the devices and media that are used for backups and restores of NDMP hosts. The NetBackup Device Configuration Wizard discovers and configures the storage devices that are attached to an NDMP host (requires NDMP protocol versions V3 or V4). Note that wizard-based discovery depends upon a number of device-specific features, such as SCSI inquiry and serialization, which some NAS vendors may not support.
High speed local backup of NDMP hosts	Backup data travels between the disk drives and tape drives that are directly attached to the same NDMP host. This transfer provides high-speed backup without slowing network throughput.
Backup of network-attached NDMP hosts to a tape device on another NDMP host or to advanced tape libraries with an embedded NDMP server	Backup data travels across the network, from a disk on an NDMP host to tape on another NDMP host. This backup is referred to as three-way backup. This data movement option requires support from the NAS/NDMP host.
Backup of a network-attached NDMP host to a tape device on a NetBackup media server	Backup data travels across the network, from a disk on an NDMP host to tape on a NetBackup media server. This backup is a form of three-way backup also known as remote NDMP. This feature supports NDMP versions V2, V3, and V4 on the NDMP hosts.
Shared tape libraries	Tape libraries can be shared between NDMP hosts and NetBackup servers, or between multiple NDMP hosts. Robotic control can be on an NDMP host or on a NetBackup server.
Shared tape drives with the Shared Storage Option	Tape drives can be shared between servers (both NetBackup servers and NDMP hosts). This setup requires the Shared Storage Option (SSO) license. See “NDMP information on the Web” on page 34.
Snapshots of data on NDMP hosts	NetBackup can make point-in-time data snapshots on an NDMP (NAS) host without interrupting client access to data, using the NDMP V4 snapshot extension. The snapshot is stored on the same device that contains the NDMP client data. From the snapshot, you can restore individual files or roll back a file system or volume by means of Snapshot Client Instant Recovery. A NetBackup Snapshot Client license is required, in addition to the NetBackup for NDMP license. This Snapshot Client feature uses the NAS_Snapshot method. Refer to the <i>NetBackup Snapshot Client Administrator’s Guide</i> for details.

Table 1-1 NetBackup for NDMP features (*continued*)

Feature	Description
NDMP DirectCopy	NetBackup can copy virtual tape library (VTL) images directly from the VTL to physical tape or to another VTL, without using media server I/O resources or network bandwidth. NetBackup can directly copy NDMP backup images from one NDMP-attached tape drive to another NDMP tape drive that is attached to the same NDMP host. Note that the operation does not use media server I/O. Note: The VTL must have an embedded NDMP tape server.
Direct Access Recovery (DAR)	For NDMP hosts that support DAR, this feature greatly reduces the time that is needed to restore a directory, a single file, or a small number of files.
Path-based file history	The NDMP server can send catalog information consisting of complete path names to NetBackup. Some vendors do not support this feature. Up-to-date information is available on the vendors that support path-based history. See “NDMP information on the Web” on page 34.
NetBackup for NDMP servers are supported in a NetBackup-clustered environment	The NetBackup for NDMP servers are supported in a NetBackup-clustered environment.
Enhanced ability to run customized scripts during a backup	The enhanced ability to run customized scripts during a backup, especially for relational databases residing on NAS devices.
NDMP multiplexing	NDMP multiplexing enables NDMP backups to be multiplexed to Media Manager storage units. Only remote NDMP multiplexing is supported.
NDMP to disk	NetBackup can write NDMP backups to disk storage units.
IPv6 support	NDMP supports the filers that are running the IPv6 network protocol.
NDMP support for Replication Director	NDMP support for Replication Director enables NetBackup to use NDMP for the following. You can use Backup From Snapshot, restore from snapshot backups, live browse snapshots, and restore from snapshots (for copy back method). Support all of the items provided for replicated snapshots.

NetBackup for NDMP terminology

The following table describes the NetBackup for NDMP terminology. For explanations of other NetBackup terms, consult the NetBackup online glossary in NetBackup help.

Table 1-2 Terminology

Term	Definition
DAR (Direct Access Recovery)	The NDMP host positions the tape to the exact location of the requested file(s), reading only the data that is needed for those files. Restore times can be reduced from hours to minutes.
NDMP (Network Data Management Protocol)	NDMP is a widely used protocol through which an NDMP-conformant backup application can control the backups and restores for an NDMP host.
NDMP backup to Media Manager storage units	A form of three-way backup and restore also known as Remote NDMP. Data travels from an NDMP host to a tape drive that is attached to a NetBackup media server.
NDMP client	<p>An NDMP client is an NDMP-compliant backup application (also known as a Data Management Application or DMA) that is an NDMP server application client. An NDMP client sends commands to the NDMP server application to control the backups and restores on an NDMP host.</p> <p>NetBackup for NDMP allows NetBackup to act as an NDMP client.</p>
NetBackup for NDMP server	A NetBackup for NDMP server is a NetBackup master or media server on which NetBackup for NDMP software is installed.
NDMP host	<p>An NAS system that serves files to clients using HTTP, FTP, CIFS, or NFS protocols. It also runs an NDMP server application that communicates with NDMP client backup software to configure and perform backup and restore tasks. NAS systems provide fast, multi-protocol file access and cost effective data storage to workstations and servers in the network or across the Internet.</p> <p>In a NetBackup configuration, the NDMP host is considered a client of NetBackup. However, NetBackup client software is never installed on an NDMP host.</p>

Table 1-2 Terminology (*continued*)

Term	Definition
NDMP multiplexing	NDMP multiplexing concurrently writes multiple backup streams to the same Media Manager tape storage device from the same client or different clients. NDMP multiplexing improves overall NetBackup performance by more efficient use of the storage unit drives. State of the art storage devices can typically stream data faster than client agents can create backup streams. Therefore multiple data streams can be sent to and effectively processed by a given storage unit. Remote NDMP multiplexing only is supported.
NDMP server application	An NDMP server application runs on an NDMP host and runs backup, restore, and device control commands that it receives from an NDMP-conformant backup application. The backup application (NetBackup) is considered an NDMP client. A separate instance of an NDMP server process exists for each connection to an NDMP client. That is, if two backups are in progress, an NDMP server process exists for each backup.
NDMP storage unit	An NDMP storage unit stores the backup data for an NDMP host. The tape drives in this storage unit attach directly to the NDMP host or can be configured on a SAN. Note that NDMP storage units cannot be used to store data for non-NDMP hosts, and NetBackup disk storage units cannot be used for NDMP tasks.
Redirected restore (to a different client)	In a redirected restore, files are restored to a client other than the one from which they were originally backed up. In NetBackup for NDMP, the restore data travels from an NDMP host (or NetBackup media server) with a locally attached storage device to another NDMP host on the network.
Remote NDMP	See “Configuring NDMP backup to Media Manager storage units” on page 62.
Three-way backup/restore	In a three-way backup or restore, data travels between an NDMP host and a storage device that is attached to another NDMP host or to a NetBackup media server. This backup contrasts with local NDMP backup or restore where the data travels between an NDMP host’s disk and a storage device directly attached to the same NDMP host.

Table 1-2 Terminology (*continued*)

Term	Definition
Virtual Tape Library (VTL)	A virtual tape library is a storage system that uses disk-based technology to emulate a tape library and tape drives. For secondary storage, NetBackup can copy VTL images directly to a physical tape or to another VTL, by means of NDMP DirectCopy.

Network Data Management Protocol (NDMP)

NDMP is a widely used protocol through which an NDMP-conformant backup application controls the backups and restores of any NDMP host that runs an NDMP server application.

NDMP architecture follows the client and server model:

- The NetBackup master or media server where NetBackup for NDMP is installed is called a NetBackup for NDMP server.
- The host where the NDMP server application resides is called an NDMP host.
- The NetBackup software is a client of the NDMP server application. NetBackup for NDMP lets NetBackup act as an NDMP client. The NDMP hosts, on the other hand, act as NetBackup clients.

The following figure shows an example of NDMP and NetBackup hosts as clients of each other.

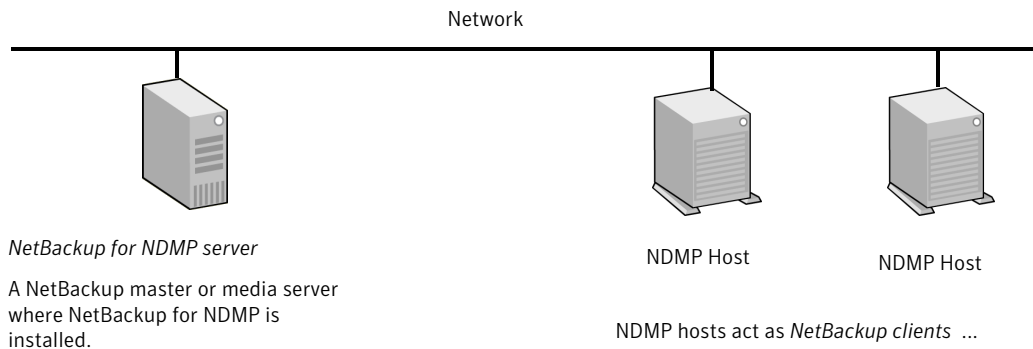
Figure 1-1 NDMP and NetBackup hosts as clients of each other

The NetBackup for NDMP server acts as an *NDMP client*.

NOTE: NetBackup software is NOT installed on NDMP hosts.

Types of NDMP backup

The NDMP server application on the NDMP host performs backups and restores of the NDMP host, directed by commands from an NDMP client (NetBackup). Backups can be conducted in any of the following ways:

- NDMP local backup
See [“NDMP local backup”](#) on page 18.
- NDMP three-way back up
See [“NDMP three-way back up”](#) on page 19.
- Backup to a Media Manager storage unit on the NetBackup server
See [“Backup to Media Manager storage units \(remote NDMP\)”](#) on page 20.

NDMP local backup

If you use the NDMP local backup, the NetBackup for NDMP server initiates the backup. The data travels from the NDMP host’s disk to a storage device that is attached to the same host or, the storage device is available on a SAN.

The following figure shows an example of an NDMP local backup and restore.

Figure 1-2 NDMP local backup and restore

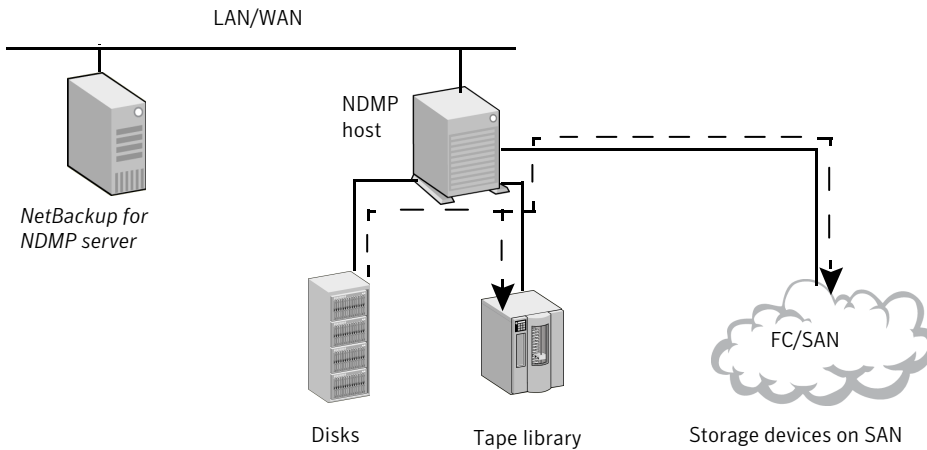

Local NDMP backup

Data travels from disk to tape on same NDMP host, or from disk to tape device on SAN. *Backup data is NOT sent over local network.*

The tape drives must be in NDMP-type storage units.

NDMP three-way back up

If you use the NDMP three-way backup, the NetBackup for NDMP server initiates the backup. Data travels over the network by going from an NDMP host to a storage device that is attached to another NDMP host on the local network or is available on a SAN.

The following figure shows an example of an NDMP three way backup and restore.

Figure 1-3 NDMP three way backup and restore

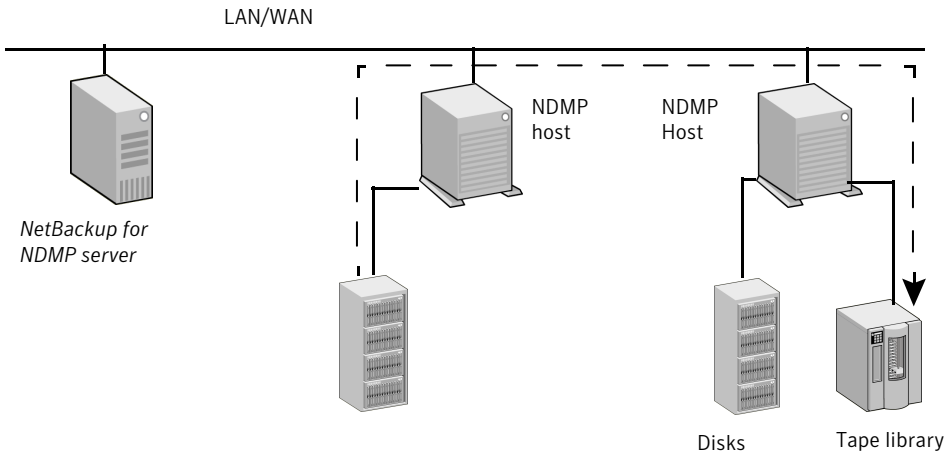

Three-Way NDMP backup

Data travels from disk on an NDMP host to tape device on another NDMP host. Backup data is sent over the local network.

The tape drives must be in NDMP-type storage units.

Backup to Media Manager storage units (remote NDMP)

If you use the backup to Media Manager storage units (remote NDMP), the data travels over the network by going from an NDMP host to a Media Manager-type storage device that is attached to a NetBackup media server or is available on the SAN. The NetBackup drive(s) must be in Media Manager storage units (not NDMP storage units).

The following figure shows an example of an NDMP backup to a Media Manager device (remote NDMP).

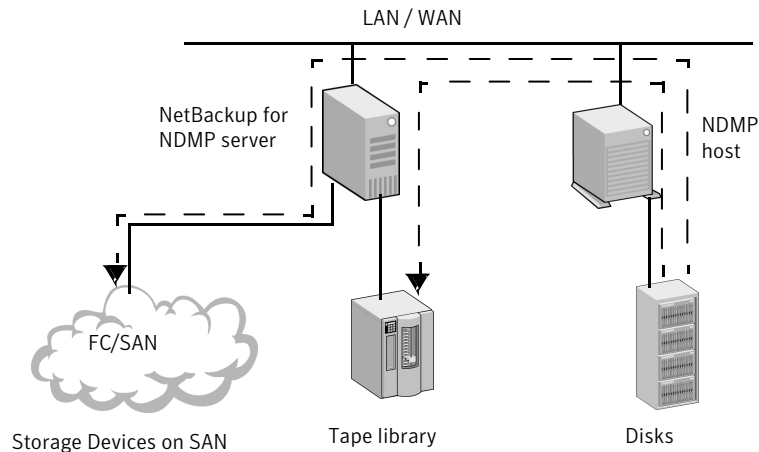
Figure 1-4 NDMP backup to a media manager device (remote NDMP)

To NetBackup Server-Attached Media Manager Storage Units

Data travels from NDMP host to a drive on a NetBackup media server or on a SAN. *Backup data is sent over the local network.*

NOTE: The NetBackup drive(s) must be in Media Manager type storage units.

NDMP policies

After you install and configure NetBackup for NDMP, you can schedule backups by creating an NDMP policy in NetBackup.

An NDMP policy can have one or more NetBackup clients. Each NetBackup client must be an NDMP host.

See [Figure 1-1](#) on page 17.

Note that you do not install any NetBackup software on the NDMP hosts.

The allowable backup types for schedules in an NDMP policy are: Full, Cumulative Incremental, or Differential Incremental. User-initiated backups and archives are not allowed because the NDMP protocol does not permit these tasks.

Restores of NDMP host backups can be initiated from any NetBackup media server that meets the following criteria:

- Resides within the same overall NetBackup storage domain
- Uses the same NetBackup master server that the media server uses to perform the backup

The data can be restored to the NDMP host where it was backed up, or to another NDMP host.

NDMP policies can use either NDMP storage units or Media Manager storage units.

NetBackup storage units

NetBackup uses either one of the following storage units:

- NDMP-type storage units (for local or three-way backup)
See “[NDMP-type storage units](#)” on page 22.
- Media Manager storage units (for backup to devices that are attached to a NetBackup media server)
See “[Media Manager storage units](#)” on page 22.

NDMP-type storage units

NetBackup requires NDMP-type storage units when you back up NDMP host data to the devices that are as follows:

- Attached to an NDMP host
- Available to the NDMP host on a SAN

An NDMP storage unit can contain stand-alone or robotic drives. Robotic controls can be in a TLD (tape library DLT), TL8 (tape library 8MM), TLH (tape library Half Inch), or ACS robot type.

Media Manager storage units

You can use the drives that were configured in Media Manager-type storage units when you back up NDMP host data to devices that are as follows:

- Attached to a NetBackup for NDMP server
- Available to the server on a SAN

For NDMP backup, drives in Media Manager-type storage units do not have to be dedicated to NDMP data. They can store backups of regular (non-NDMP) NetBackup clients as well as of NDMP clients.

About assigning tape drives to different hosts

The robotic tape drives can be divided up among NDMP hosts and NetBackup servers.

The following figure shows the NDMP and non-NDMP storage units with the following configuration:

- Tape drives 1, 3, and 5 are attached to NDMP hosts. They are in the NDMP storage units that can be used for NDMP backups (local or three way).
The commands that control these drives originate on the NetBackup for NDMP server and are sent through the NDMP connection on the network. The NDMP server application on each NDMP host translates the NDMP commands into SCSI commands for the local drives.
- Tape drives 2 and 4 are attached to a NetBackup server. They are in non-NDMP storage units and are controlled in the same way as other drives on NetBackup servers. Depending on the type of storage unit, these drives can be used for the following:
 - Non-NDMP clients of NetBackup
 - In the case of tape drives in Media Manager storage units, they can be used for both NDMP (local or three way) and non-NDMP backups.

In the following figure, all of the tape drives except drive 4 are used for NDMP backup.

Figure 1-5 NDMP and non-NDMP storage units

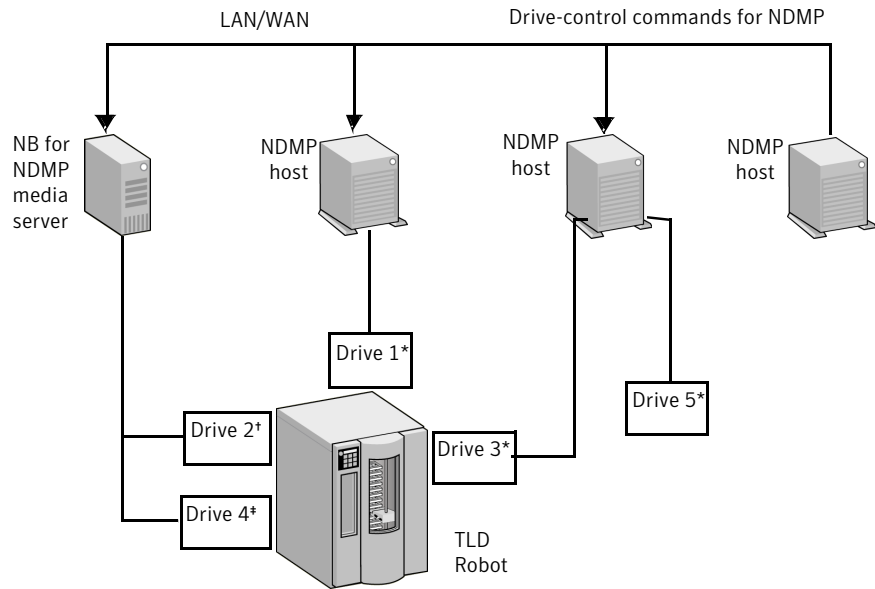

- * In NDMP storage unit
- † In NetBackup Media Manager storage unit
- ‡ In another type of NetBackup storage unit (not NDMP or Media Manager)

Drives 1, 3, and 5 (in NDMP storage units) can be used for NDMP backups.

Drive 2 (in Media Manager storage unit) can be used for NDMP or non-NDMP backup.

Drive 4 (in different type of NetBackup storage unit) cannot be used for NDMP backup.

NDMP host

Robotics control can be attached to an NDMP host or to a NetBackup server.

The following figure shows how NetBackup sends commands over the network to the NDMP host, which in turn sends them to the robot.

Figure 1-6 Robotics control that is attached to an NDMP host

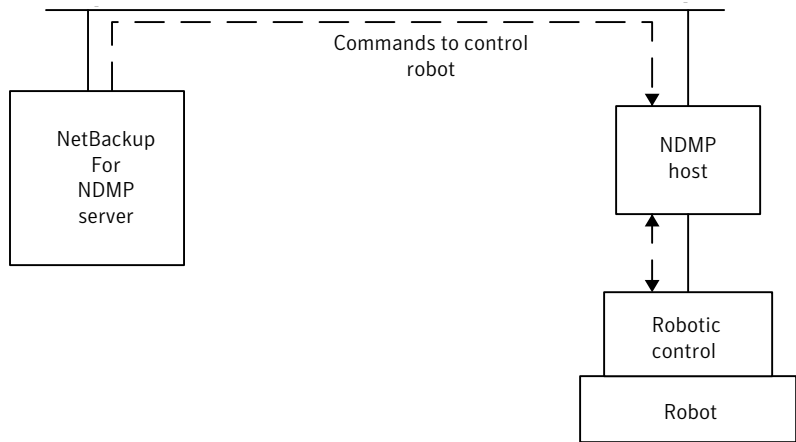

NetBackup server

The following figure shows how the robot is controlled in the same way as the other robots on NetBackup servers.

Figure 1-7 Robotics control that is attached to a NetBackup server

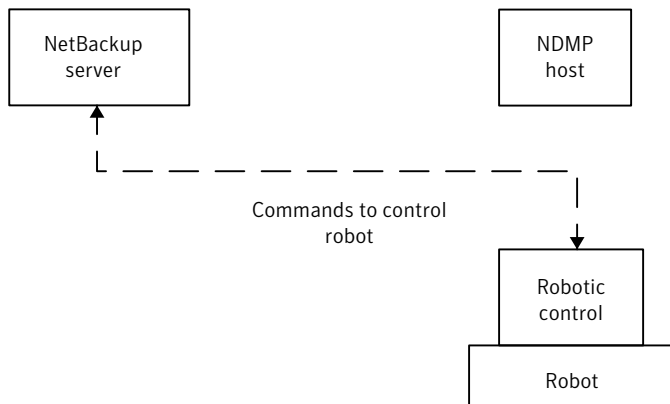

NDMP backup process

During a backup, the following events occur in this order:

- From the EMM database, NetBackup obtains a media ID for the tape that is used for the backup and sends a tape-mount request to `ltid`.
- `ltid` on the NetBackup for NDMP server sends the necessary NDMP (SCSI robotic) commands to mount the requested tape on the storage device.
- NetBackup sends the NDMP commands that are necessary to have the NDMP server application perform a backup to the tape. The backup data travels in one of two ways:
 - Between the local disk and tape drives on an NDMP host.
 - Over the network, data travels from an NDMP host without its own storage device to an NDMP host (or NetBackup media server) with a locally attached storage device (three-way back up).
- The NDMP server application sends information to the NetBackup for NDMP server about the files that were backed up. This information is stored in the NetBackup file database.
- The NDMP server application sends status about the backup operation to the NetBackup for NDMP server.

The following figure shows the NetBackup processes that are involved in the NDMP backups.

Figure 1-8 NetBackup backup processes

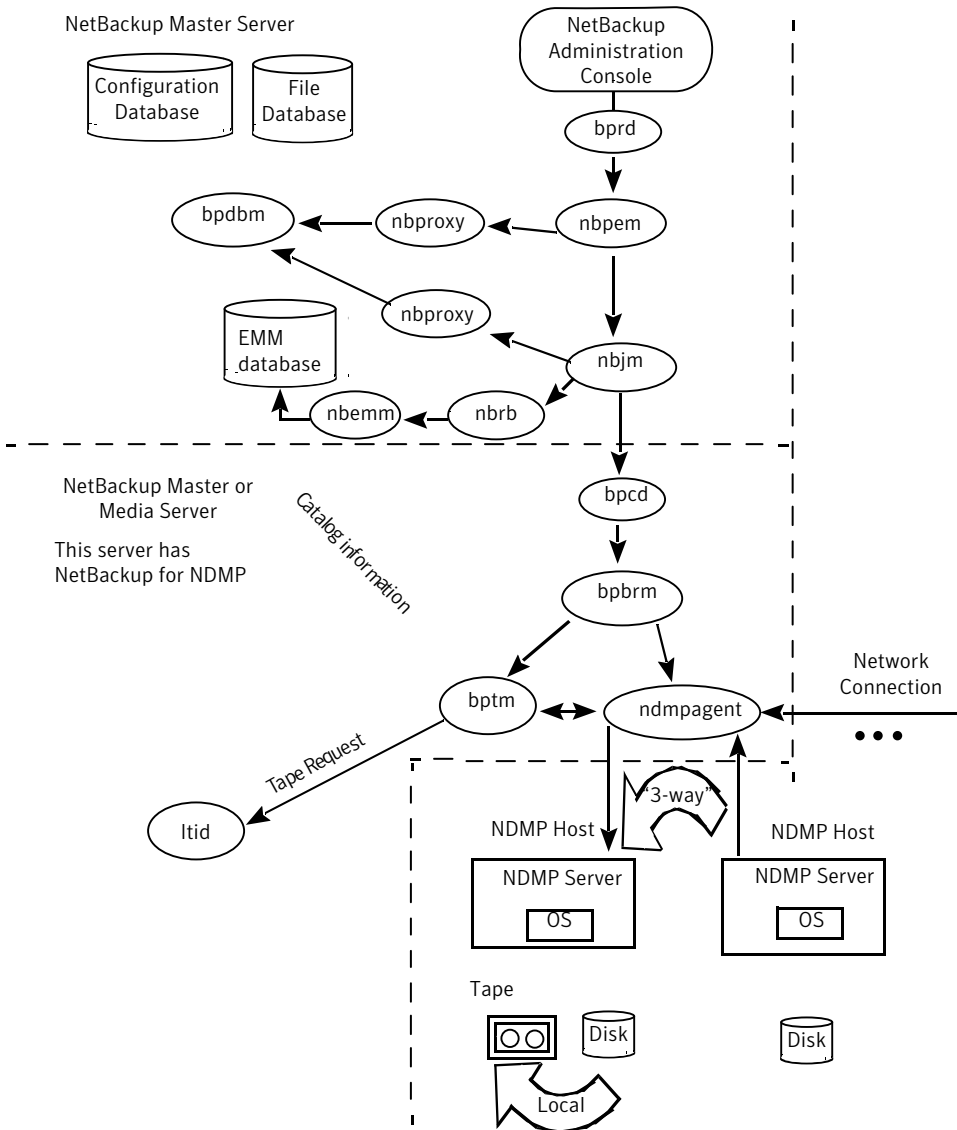

NDMP restore process

Because of the design of the NDMP protocol, only an administrator on a NetBackup server (master or media) can restore files from NDMP backups. During a restore,

the administrator browses the file catalog and selects files from NDMP images in the same manner as for standard backup images.

The following events occur during a restore, in this order:

- The NetBackup for NDMP server looks in its EMM database for the tape that contains the backup, and asks `ltid` to mount that tape.
- `ltid` on the NetBackup for NDMP server sends the necessary NDMP commands to load the requested tape on the storage device.
- NetBackup sends the NDMP commands that are necessary to have the NDMP server application perform a restore operation to the disk. The restore data travels in one of two ways:
 - From a tape drive to a local disk (tape drive and disk are on the same NDMP host)
 - Over the network, from an NDMP host (or NetBackup media server) with a locally attached storage device to another NDMP host (three-way backups or restores)
- The NDMP server application sends status about the restore operation to the NetBackup for NDMP server.

The following figure shows the NetBackup processes involved in NDMP restores.

Figure 1-9 NetBackup restore processes

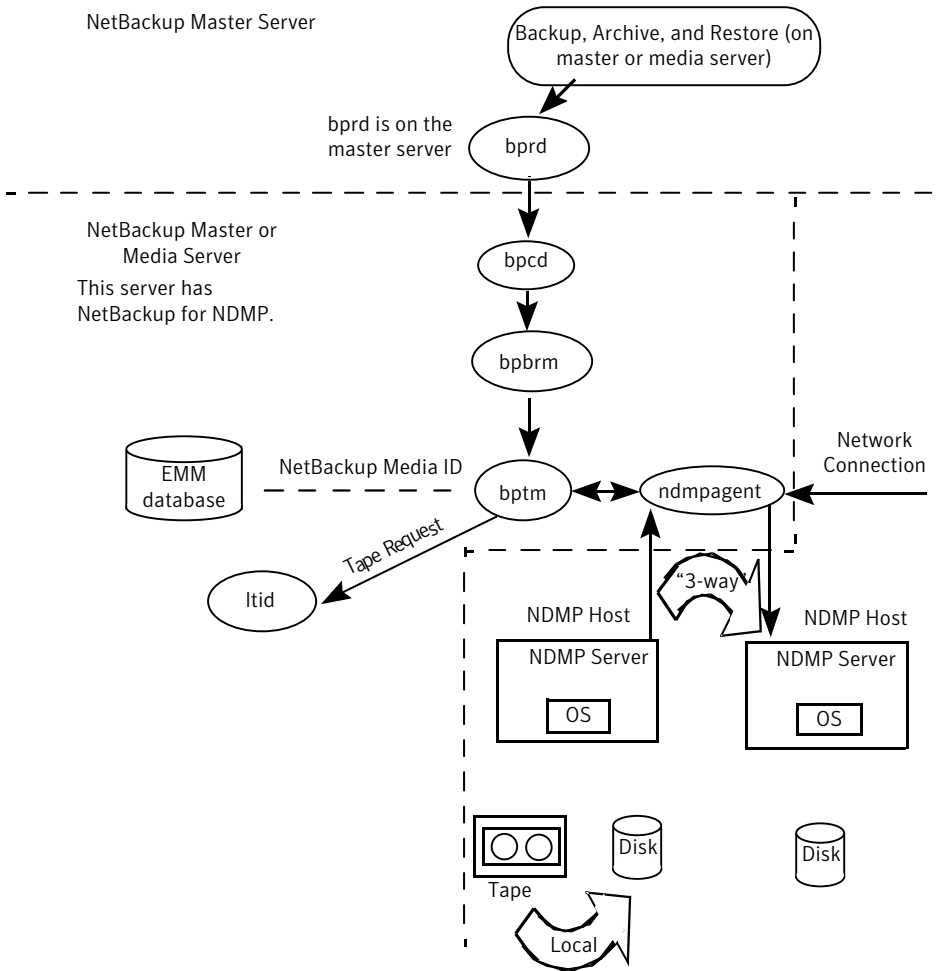

Direct Access Recovery (DAR)

NetBackup uses Direct Access Recovery (DAR) to restore a directory or individual files from a backup image. DAR can greatly reduce the time it takes to restore files and directories. DAR is enabled by default (no configuration is required).

DAR enables the NDMP host to position the tape to the exact location of the requested file(s). It reads only the data that is needed for those files. For individual file restore, NetBackup automatically determines whether DAR shortens the

duration of the restore. It activates DAR only when it results in a faster restore. Further details are available as to when DAR is used and how to disable it.

See “[About enabling or disabling DAR](#)” on page 57.

The following two prerequisites are necessary for using DAR with NetBackup for NDMP:

- The NDMP host must support DAR where the NDMP server application resides.
- NetBackup 4.5 GA or later, with the catalog in binary format (binary format is the default).

NDMP DirectCopy with VTL

NetBackup supports virtual tape libraries (VTLs). A virtual tape library uses disk-based technology to emulate a tape library (robot) and drives. The backup image is written to one or more disks in the VTL. The VTL allows the image to be treated as though it resides on tape, but with the access speed of a disk.

For additional storage (such as for disaster recovery), NetBackup copies backup images from the VTL disk to a physical tape in an NDMP storage unit. It copies without using media server I/O or network bandwidth. NetBackup can also copy NDMP images directly between NDMP tape drives attached to an NDMP host. In both cases, this feature is called NDMP DirectCopy. This feature also enables NetBackup to restore data directly from either the image in the VTL or from, the physical NDMP tape.

To initiate the NDMP DirectCopy, you can use the NetBackup duplication feature in the **NetBackup Administration Console**, the `bpduplicate` command, or NetBackup Vault.

The following figure represents a VTL from two perspectives; it shows the actual hardware present in a VTL configuration and the configuration from the perspective of NetBackup.

Figure 1-10 Overview of NDMP DirectCopy with VTL

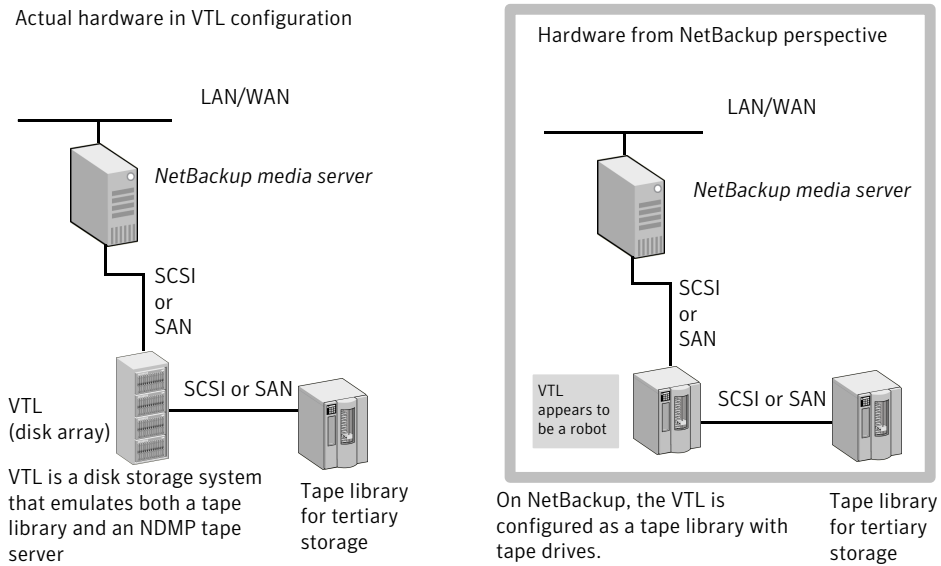

The NDMP DirectCopy feature uses a VTL that has an embedded NDMP tape server using the NDMP protocol. The embedded NDMP tape server moves the image from the VTL disk directly to a physical tape. The image does not pass through the NetBackup media server or travel over the network.

The following figure shows the data flow and control for a VTL.

Figure 1-11 NDMP DirectCopy with VTL data flow and control

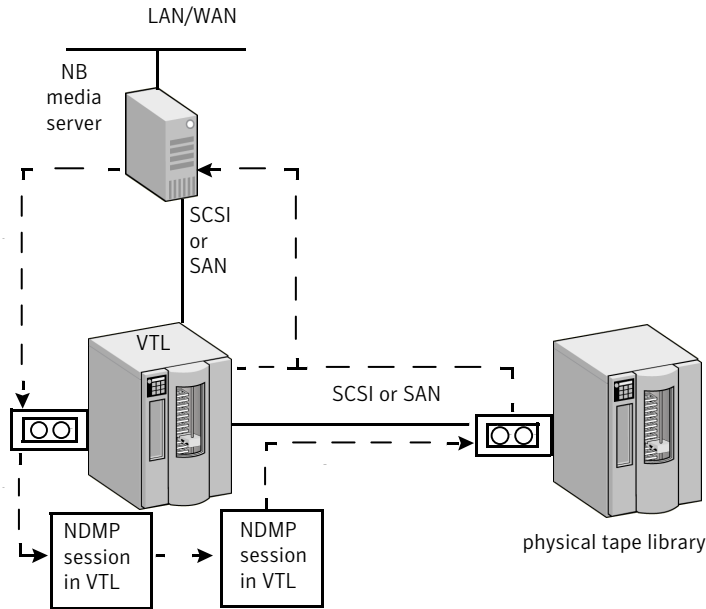

1. NetBackup media server sends the backup over a direct device path (SCSI or SAN) to the VTL.
2. NetBackup selects an NDMP device path to the VTL and creates an NDMP control session for the device.
3. NetBackup selects a tape volume from the physical tape library. It then selects an NDMP device path from the library and creates a second NDMP control session for the device.
4. By means of the NDMP protocol, the backup image in the VTL is copied directly to the physical tape library (not sent over the network).
5. The image can be restored directly to the media server from either the VTL or the physical tape.

NDMP DirectCopy without VTL

By means of the NetBackup duplication feature, NetBackup can copy NDMP images between tape drives attached to an NDMP host. A typical usage is to copy images between tape drives within the same tape library. (Images can also be copied between tape libraries.) Like NDMP DirectCopy with a VTL, the copied data does not pass through the NetBackup media server or travel over the network.

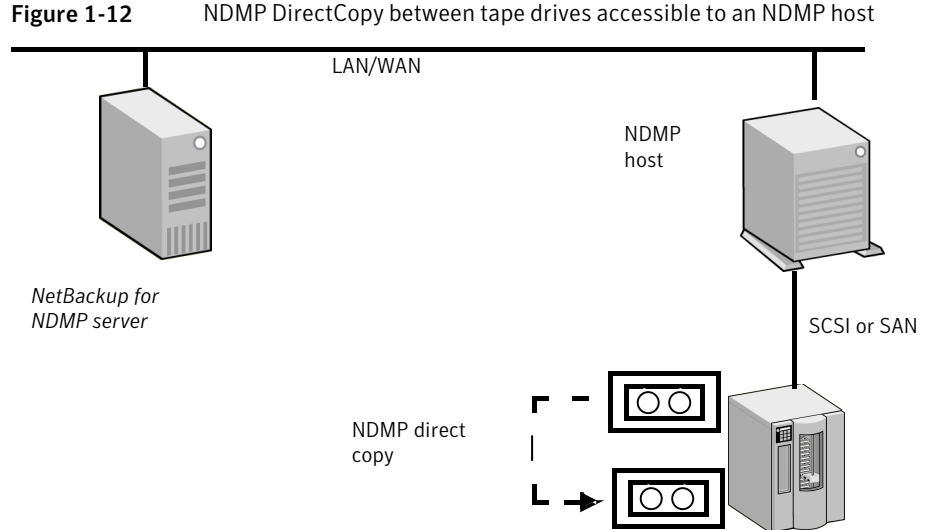

NDMP DirectCopy notes and limitations

Note the following about NDMP DirectCopy:

- Supports backup to tape and restore from tape, for NDMP data as well as non-NDMP data. Tape-to-tape duplications of backup images are also supported.
- Does not support synthetic backup or multiple copies.
- Does not support multiplexed backup.
- Does not support storage unit groups for the destination device. If you select a storage unit group, NDMP DirectCopy is disabled. The data transfer takes place over the network by means of the NetBackup server.
- In a VTL environment, a NAS appliance is not required; the VTL emulates a NAS (NDMP) host. The VTL requires NDMP tape server functionality.
- NetBackup for NDMP software must be installed. NetBackup for NDMP is enabled by the Enterprise Disk Option license. Requires the NDMP protocol version V4 or higher.
- NetBackup servers (master and media) must be at NetBackup 6.5 or later.
- The NetBackup 7.x hardware compatibility list (HCL) indicates which VTL software supports this functionality:
<http://entsupport.symantec.com/docs/336875.htm>

NDMP information on the Web

The Symantec support Web site has a PDF document on supported NDMP operating systems and NAS vendors. The document is titled *NetBackup for NDMP: NAS Appliance Information*. It also contains configuration and troubleshooting help for particular NAS systems:

<http://entsupport.symantec.com/docs/267773>

For the features and software releases for each NAS vendor, for SSO support, and for the NetBackup versions that support these vendors, refer to the NetBackup 7.x hardware compatibility list (HCL):

<http://entsupport.symantec.com/docs/336875.htm>

Snapshot Client assistance

For Snapshot Client assistance, see the *NetBackup Snapshot Client Administrator's Guide*. For additional information, see the Snapshot Client Configuration document:

<http://entsupport.symantec.com/docs/288300>

Document 288300 includes the following:

- An up-to-date list of supported operating systems and peripherals
- A list of NAS vendors that are supported for the NAS_Snapshot method
- Sections on SAN device configuration and on setting up NetBackup for off-host data mover backups (including instructions on creating `3pc.conf` and `mover.conf` files)

NDMP multiplexing

NDMP multiplexing concurrently writes multiple backup streams to the same tape storage device from the same client or different clients. NDMP multiplexing only supports remote NDMP and improves overall NetBackup performance by better using tape storage devices. State of the art tape storage devices can typically stream data faster than client agents can create backup streams. Therefore multiple data streams can be sent to and effectively processed by a given tape storage unit.

A Network Attached Storage (NAS) device with an NDMP server is an agent that produces a backup stream that is similar to a NetBackup client. Multiplexing is desired for NDMP backups because NAS devices are limited in the rate at which

they create backup streams. These backup streams are often much slower than the tape storage device consuming and writing the stream.

NDMP multiplexing provides the following features:

- Several backups can be run at the same time writing to the same tape. This process can reduce the need for many tape devices.
- Backup time is reduced by writing concurrent backups to a single tape storage device.
- Many tape storage devices require that data is streamed to them at high transfer rates. When data is not streamed fast enough, they do not work efficiently and are subject to possible excessive wear.

NDMP multiplexing general considerations

Consider the following general items when implementing NDMP multiplexing.

- Only media manager tape storage units can be used for NDMP multiplexing.
- Multiplexing of NDMP backups and restores only supports remote NDMP. The remote NDMP processes backup streams by going through the media server.
- NDMP local and NDMP three-way backups and restores are not supported for NDMP multiplexing. Each of these methods process backup streams without going through the media server.
- Synthetic backups are not supported.
- Only tape devices are supported.
- Disk storage devices are not supported.
- A mix of NDMP and non-NDMP backups can be present in the same MPX backup group.
- File and directory DAR are allowed.
- NDMP multiplexing works with both VTL and PTL. However, VTL users typically do not use NDMP multiplexing because they can add more virtual tape devices to accommodate additional streams.
- For NDMP multiplexed backups the storage unit and policy schedule multiplex value must be set to a value greater than one.

NDMP IPv6 address data connections

NDMP supports 128-bit IPv6 address data connections in addition to the 32-bit IPv4 address data connections. NDMP data connections are made between filers

or between a NetBackup media server and a filer that is used to transfer the backup image.

NDMP IPv6 general considerations

Consider the following general items when using NDMP IPv6 address data connections.

- The filer needs to be enabled for IPv6 data communication.
- By default the NetBackup media server is enabled for IPv6 data communication.
- The filer vendor must support connection address extension or full IPv6.

About NDMP support for Replication Director

Replication Director enables NetBackup to use NDMP to perform the following operations:

- Restore from snapshot backups.
- Perform a live browse of snapshots.
- Restore from snapshots for the copy back method.

Support for all of the operations is provided for replicated snapshots as well.

Consider the following items before configuring NDMP to be used with Replication Director:

- To use the Point in Time rollback restore method, select the **Skip verification and force rollback** operation.
- To restore from backups for a standard or Windows client, all destinations must be mounted and shared from a compatible filer. All destinations must be on the same filer.
- To restore from backups for a standard or Windows client, do not mix backup selections: selections created from a policy with NDMP **Data Mover** enabled and selections from a policy without NDMP **Data Mover** enabled.
- User restores can be directed to any volume that the user can NFS or CIFS mount. Denying NFS or CIFS write access does not prevent the restore because the filer performs an NDMP restore.

Limitations of NDMP support for Replication Director

Replication Director and NDMP does not support the following items:

- The Solaris_x86 operating system is not supported.
- The **Multiple copies** NetBackup policy option is not supported for image copies in the NDMP data format.
- The **Restore the file using a temporary filename** restore option is not supported on Windows clients.
- Restores to a local file system are not supported with a **MS-Windows** or **Standard** policy that has the NDMP **Data Mover** enabled.
- Do not create a **MS-Windows** or **Standard** policy that contains backup selections that are on different filers. However, backup selections on different filers are supported if multistreaming is configured so that each backup selection is backed up in a separate job.
- Volume snapshot replication of `qtree` and `non-qtree` data is not supported.
- Only one NDMP backup of a snapshot per `backupid` is allowed.

Installing NetBackup for NDMP

This chapter includes the following topics:

- [NetBackup for NDMP installation prerequisites](#)
- [Installing NetBackup for NDMP on UNIX servers](#)
- [Installing NetBackup for NDMP on Windows servers](#)
- [Uninstalling NetBackup for NDMP](#)

NetBackup for NDMP installation prerequisites

Note the following items:

- The NetBackup for NDMP master or media server must run NetBackup 7.0 or later.
- For a list of operating systems that NetBackup 7.1 for NDMP supports, refer to the NetBackup 7.x operating system Compatibility List.
<http://seer.entsupport.symantec.com/docs/337048.htm>
- For a detailed list of NAS platforms that NetBackup for NDMP supports, refer to the following document:
<http://seer.entsupport.symantec.com/docs/267773.htm>
- For making snapshots of NDMP (NAS) hosts, NetBackup Snapshot Client software must be installed on the NetBackup master server and the NetBackup clients that are used to perform backups.
For more information, refer to the *NetBackup Snapshot Client Administrator's Guide*.

- The drives and robots that are attached to the NDMP host must be the types that the NDMP host and NetBackup support. A list of supported robot types is available.
See “[NDMP-type storage units](#)” on page 22.
For more information on storage devices, see the *NetBackup Administrator’s Guide, Volume I*.
- Notes and tips on your particular NDMP host are available.
See “[NDMP information on the Web](#)” on page 34.

Installing NetBackup for NDMP on UNIX servers

NetBackup for NDMP installs on a UNIX or Linux system when the NetBackup server software is installed. No separate installation procedure is required. However, you must enter a valid license key to use NDMP. On the UNIX host that you want to be the NetBackup for NDMP server, perform the following procedure.

Note: If you install in a cluster environment, first freeze the active node so that migrations do not occur during installation. For information about freezing a service group, see the clustering section in the *NetBackup High Availability Administrator’s Guide* for the cluster software you are running.

To install NetBackup for NDMP on UNIX servers

- 1 Log on as root.
- 2 Install NetBackup server and client software as explained in the *NetBackup Installation Guide for UNIX and Linux*.
- 3 To make sure a valid license key for NetBackup for NDMP is registered, enter the following command to list and add keys:

```
/usr/opensv/netbackup/bin/admincmd/get_license_key
```
- 4 If this NetBackup for NDMP server is not your master server, install your NDMP license key on the master.
- 5 In a clustered environment, perform these steps on each node in the cluster.
- 6 If you install in a cluster environment, unfreeze the active node after the installation completes.

For information about unfreezing a service group, see the clustering section in the *NetBackup High Availability Administrator’s Guide* for the cluster software you are running.

Installing NetBackup for NDMP on Windows servers

Use the following procedure on the Windows host that you want to be the NetBackup for NDMP server.

Note: If you install in a cluster environment, first freeze the active node so that migrations do not occur during installation. For information about freezing a service group, see the clustering section in the *NetBackup High Availability Administrator's Guide* for the cluster software you are running.

To install NetBackup for NDMP on Windows servers

- 1 Log on.
- 2 Install NetBackup server and client software as explained in the *NetBackup Installation Guide for Windows*.
- 3 NetBackup for NDMP is part of the core NetBackup product. To make sure a valid license key for NetBackup for NDMP is registered, do the following to list and add keys:
 - In the **NetBackup Administration Console**, select **Help**.
 - On the **Help** menu, select **License Keys**.
 - Existing keys are listed in the lower part of the window.
 - To register a new key, click the star icon to open the **Add a new License Key** dialog box. Type the new license key in the **New license key** field and click **Add**.

The new license key appears in the lower part of the dialog box.

- 4 If this NetBackup for NDMP server is not your master server, install your NDMP license key on the master.
- 5 In a clustered environment, perform these steps on each node in the cluster.
- 6 If you install in a cluster environment, unfreeze the active node after the installation completes.

For information about unfreezing a service group, see the clustering section in the *NetBackup High Availability Administrator's Guide* for the cluster software you are running.

Uninstalling NetBackup for NDMP

This procedure uninstalls NetBackup for NDMP (and all of NetBackup).

To uninstall NetBackup

- 1 On the master server, check the Activity Monitor in the **NetBackup Administration Console**. Make sure that no NetBackup for NDMP backups are active or running for the client (the **Job State** field should read `Done`).
- 2 Perform the uninstall procedure that is described in the *NetBackup Installation Guide*. Note that the procedure uninstalls all of NetBackup.

Configuring NDMP backup to NDMP-attached devices

This chapter includes the following topics:

- [About configuring NDMP-attached devices](#)
- [Authorizing NetBackup access to the NDMP host](#)
- [About access for three-way backups and remote NDMP](#)
- [Media and Device Management configuration](#)
- [Adding a robot directly attached to an NDMP host](#)
- [Adding a drive](#)
- [Checking the device configuration](#)
- [About adding volumes](#)
- [About verifying NDMP password and robot connection](#)
- [Adding NDMP storage units](#)
- [About creating an NDMP policy](#)
- [Required Attributes tab options for an NDMP policy](#)
- [Required Schedules tab options for an NDMP policy](#)
- [Required Clients tab options for an NDMP policy](#)
- [Required backup selections options for an NDMP policy](#)
- [About environment variables in the backup selections list](#)

- [Backup types in a schedule for an NDMP policy](#)
- [About enabling or disabling DAR](#)
- [Disabling DAR for file and directory restores](#)
- [Disabling DAR for directory restores only](#)
- [Setting up clustering](#)
- [Post-installation changes](#)
- [About testing an NDMP configuration](#)

About configuring NDMP-attached devices

This topic explains how to configure backups on the storage devices that are attached to NDMP hosts. Only the NDMP-specific steps are described.

You can also use the NetBackup **Device Configuration Wizard** to discover and configure the robots and drives that are attached to an NDMP host. The wizard requires NDMP protocol versions V3 or V4.

To configure and use the NAS_Snapshot method, see the *NetBackup Snapshot Client Administrator's Guide*.

Authorizing NetBackup access to the NDMP host

Before NetBackup can perform backups, it must have access to the NDMP host.

Note: Perform the following procedure on the master server (not media server) if you plan to create snapshots using the Snapshot Client NAS_Snapshot method.

To authorize NetBackup access to the NDMP host

- 1 On the NetBackup server **NetBackup Administration Console**, expand **Media and Device Management > Credentials > NDMP Hosts**.
- 2 Under the **Actions** menu, select **New > New NDMP Host**.
- 3 In the **Add NDMP Host** dialog box, enter the name of the NDMP server for NetBackup to back up.

The NDMP host name is case-sensitive. Whenever this host name is used, the name must be identical to the name entered here. (For example, when you configure tape drives and storage units for this host.)

- 4 Click **OK**.
- 5 In the **New NDMP Host** dialog box, specify the following:
 (The term credentials refer to the user name and password that NetBackup uses to access the NDMP host.)

Use global NDMP credentials for this NDMP host Enables all NetBackup media servers under the master server to access this NDMP host using a predefined global NDMP logon.

To create this logon, click **Host Properties > Master Server > Properties > NDMP** in the **NDMP Global Credentials** dialog box.

Use the following credentials for this NDMP host on all media servers Enables all NetBackup media servers that are connected to the NDMP host to access the NDMP host using the logon you specify:

- **User name:** The user name under which NetBackup accesses the NDMP server. This user must have permission to run NDMP commands.
- **Password** and **Confirm Password:** Enter the password for this user.

Use different credentials for this NDMP host on each media server Specifies NDMP logons for particular NetBackup servers. Then click **Advanced Configuration**.

- In the **Advanced NDMP Credentials** dialog box, click **Add**.
- In the **Add Credentials** dialog box, select a NetBackup server and specify the user name and password it uses to access the NDMP host.
- Click **OK**. NetBackup validates the user name and password.
- The NetBackup server and user name appear in the **Advanced NDMP Credentials** dialog box.
- If necessary, click **Add** again to specify other servers and user

- 6 Repeat this procedure for each NDMP host that NetBackup backs up.

About access for three-way backups and remote NDMP

To perform three-way backups, you must authorize access to the NDMP host as described in the previous section.

Note the following points:

- Three-way backups; for the **NDMP host name**, specify the NDMP host that has no attached tape drive.
- NDMP to Media Manager storage units (remote NDMP); for the **NDMP host name**, specify the NDMP host to back up to the Media Manager storage unit that is defined on the NetBackup server.

See “[About remote NDMP](#)” on page 61.

Media and Device Management configuration

On the NetBackup for NDMP server, use **Media and Device Management** in the **NetBackup Administration Console** to add drives and robots. As an alternative, you can use the NetBackup **Device Configuration Wizard**.

The following procedures and examples treat NDMP configuration issues only.

See the *NetBackup Administrator's Guide, Volume I*, for general information on configuring NetBackup media.

More information on configuring storage devices for specific NDMP hosts is available.

See “[NDMP information on the Web](#)” on page 34.

These procedures do not apply to setting up the devices that are attached to the NetBackup media server. To back up NDMP data to media servers, you must configure storage units in the same way as ordinary NetBackup (non-NDMP) devices.

See “[About remote NDMP](#)” on page 61.

See also the *NetBackup Administrator's Guide, Volume I*.

Adding a robot directly attached to an NDMP host

This procedure describes how to configure a robot that is attached to an NDMP host.

To add a robot directly attached to an NDMP host

- 1 Start the **NetBackup Administration Console** on the NetBackup for NDMP server as follows:

Windows In the Windows **Start** menu, click **Programs > Symantec NetBackup > NetBackup Administration Console**.

UNIX Enter the following:

```
/usr/openv/netbackup/bin/jnbSA &
```

- 2 Expand **Media and Device Management > Devices** in the left pane.
- 3 On the **Actions** menu, select **New**. Then select **New Robot** from the pop-up menu .

4 In the **Add Robot** dialog box, select the following:

- | | |
|------------------------------------|--|
| Media Manager host | Specify the host that manages the EMM database (by default, this host is the NetBackup master server). |
| Device host | Use the pull-down to select the NetBackup media server. |
| Robot type | Specify type. |
| Robot number | Specify number. |
| Robot control | Click Robot control is attached to an NDMP host . |
| Robot device path | Enter the device name of the robot. You do not need to include the NDMP host name as part of the device path.

You can determine the device name of the robot. More information on your NDMP host is available.

See “NDMP information on the Web” on page 34. |
| NDMP host name | Enter the name of the NDMP host to which the robot is attached |
| Bus, Target, and LUN values | Specify these values if the NDMP host requires them. By default, the bus, target, and LUN values are 0.

More information on your NDMP host is available.

See “NDMP information on the Web” on page 34. |

Explained in online help or in the *NetBackup Administrator's Guide, Volume I*.

Explained in the following steps.

The screenshot shows the 'Add a New Robot' dialog box with the following configuration:

- Media Manager host: ste
- Device host: ste
- Robot type: TLD - Tape Library DLT
- Robot number: 0
- Robot name: TLD(0)
- Robot control:
 - Robot is controlled locally by this device host.
 - Robot control is handled by a remote host.
 - Robot control is attached to an NDMP host.
- Robot device path: o2i3i0
- NDMP host name: qe
- Bus: 2
- Target: 3
- LUN: 0

For further assistance with the **Add Robot** dialog box, refer to the online Help. The following steps explain the portions that are unique to configuring NetBackup for NDMP.

- 5 Click **OK**.
- 6 In the pop-up message that asks if you want to stop and restart the device manager service (or daemon), click **Yes**.

Adding a drive

This procedure describes how to configure a tape drive.

To add a drive

- 1 In the **NetBackup Administration Console**, select **Media and Device Management > Devices** in the left pane.
- 2 On the **Actions** menu, select **New**.
- 3 In the popup, select **New Tape Drive** (on UNIX, **Tape Drive**).
- 4 In the **Add a New Drive** dialog box, in the **Drive Name** box, enter the name of the drive.

Add a New Drive

Drive name: Use drive name rules

Host and path information

Enabled	Host	NDMP ...	Path	Serial N...	Port	Bus	Target	Lun
<input checked="" type="checkbox"/>	ba	toaster...	nrst2a					

Drive information

Drive type: Cleaning frequency (in hours):

Drive is in a robotic library.

Robotic library:

Robot drive number:

- 5 Click **Add** to specify a drive path.

- 6 In the **Add Path** dialog box, select the host and the path information as follows:

Device host Select the name of the NetBackup media server. Use the pull-down to select media servers already defined, or click **Add** to enter a new one.

Path Enter the device file name of the tape drive, such as nrst2a. Refer to the NAS vendor documentation for your drive for the correct format of the device file name.

An alternate method is to use the following command to find the device file name for the drive, if the NDMP host is running NDMP protocol V3 or later:

```
tpautoconf -probe ndmp_host_name
```

- 7 Click **This path is for a Network Attached Storage device**.
- 8 In the **NDMP Host** drop-down list, select the name of the NAS filer to which the drive is attached.
- 9 Click **OK**.
- 10 Return to the **Add a New Drive** dialog box and enter the drive information as required. Repeat this procedure for each drive that must be added.

When you are prompted to restart the Media Manager device daemon and all robotic daemons, click **Yes**.

Checking the device configuration

On the NetBackup for NDMP server, use the following procedure to check the device configuration.

To check the device configuration

- 1 On UNIX, execute `/usr/openv/volmgr/bin/vmps`
Verify `ltid`, `vmd`, `avrd`, and any required robotic daemons are active.
- 2 On Windows, go to the **NetBackup Administration Console**.
Click **Activity Monitor** and in the right pane, click the **Processes** tab to verify `ltid`, `vmd`, `avrd`, and any required robotic daemons processes are active.
- 3 From the **NetBackup Administration Console**, click **Device Monitor** and check the drive status to ensure that the drive is in the UP state.

About adding volumes

Use the NetBackup **Media and Device Management** utility to add the volumes that you plan to use for the NDMP host backups.

See the *NetBackup Administrator's Guide, Volume I*, for instructions.

When you specify the **Robot control host** for a volume that is in a robot, specify the host name for the NetBackup for NDMP server. Do not specify the NDMP host.

About verifying NDMP password and robot connection

When you authorize NetBackup access to the NDMP host and configure robots using the **NetBackup Administration Console**, NetBackup automatically verifies the NDMP credentials and the robotic configuration. If you want, you can re-verify them. For example:

```
tpautoconf -verify ndmp_host_name
```

A successful verification looks like the following:

```
Connecting to host "stripes" as user "root"...  
Waiting for connect notification message...  
Opening session--attempting with NDMP protocol version 4...  
Opening session--successful with NDMP protocol version 4  
  host supports MD5 authentication  
Getting MD5 challenge from host...  
Logging in using MD5 method...  
Host info is:  
  host name "stripes"  
  os type "NetApp"  
  os version "NetApp Release 7.0.0.1"  
  host id "0033625811"  
Login was successful  
Host supports LOCAL backup/restore  
Host supports 3-way backup/restore
```

Adding NDMP storage units

On the NetBackup master server, add an NDMP-type storage unit for the devices that contain the backup data. Most of the requirements are the same as for adding a Media Manager storage unit. The following explains how to add an NDMP storage unit.

See the *NetBackup Administrator's Guide, Volume I*, for more information on storage units.

The NDMP-type storage units are not used for backups to devices that are attached to NetBackup media servers. Use a non-NDMP storage unit instead.

See “[About remote NDMP](#)” on page 61.

To add NDMP storage units

- 1 In the **NetBackup Administration Console**, select **NetBackup Management > Storage**.
- 2 On the **Actions** menu, select **New > New Storage Unit**.
- 3 In the **New Storage Unit** dialog box, enter the following:

Storage unit name	Enter a unique name for the storage unit.
Storage unit type	Select NDMP .
On demand only	Specify whether the storage unit is available only when a policy or schedule specifically requests it. If this option is not used, the storage unit is available to any NDMP policy or schedule.
Storage Device	Select the type of device for this storage unit.
Media server	Select the media server associated with this storage unit.
Maximum concurrent write drives	Select the maximum number of drives for concurrent writing.
Reduce fragment size to	Enter the minimum fragment size for this storage unit.
Enable multiplexing	Select this item to enable NDMP multiplexing.
Maximum streams per drive	Select the maximum number of data streams to use with NDMP multiplexing.
	Note: You must select at least two data streams.

The remaining fields are described in the *NetBackup Administrator's Guide, Volume I*.

About creating an NDMP policy

On the NetBackup master server, you must create an NDMP policy to configure backups of the NDMP host.

Note: You can use the **Backup Policy Configuration Wizard** to create NDMP policies.

Creating an NDMP policy is very similar to creating other NetBackup policy types. The following topics explain the differences when creating NDMP policies.

See the *NetBackup Administrator's Guide, Volume I*, for more information on NetBackup policies and the Policy utility.

To configure a policy for the NAS_Snapshot method, see the *NetBackup Snapshot Client Administrator's Guide*.

Required Attributes tab options for an NDMP policy

The following policy attributes are required when you create an NDMP policy:

Note: Some of the policy options in this list are necessary when configuring NDMP support with Replication Director.

Policy Type: NDMP	Do not select any other policy type.
Policy Storage Unit	<ul style="list-style-type: none">■ To direct backups for this policy to a specific storage unit if the NDMP host has multiple storage units, specify that storage unit name.■ For a three-way backup, specify a storage unit that was defined for the target NDMP host with attached tape.■ For NDMP backup to Media Manager storage units, specify a Media Manager storage unit that is defined for a device that is connected to a NetBackup media server. See the topic on remote NDMP.
Perform off-host backup	Select the Perform off-host backup option . Use this option when configuring NDMP support with Replication Director.
Use: Data mover	Select the data mover. Use this option when configuring NDMP support with Replication Director.
Machine: NDMP	Select the NDMP computer. Use this option when configuring NDMP support with Replication Director.

Required Schedules tab options for an NDMP policy

In the schedules list under the **Attributes** tab, the following is optional for each schedule in an NDMP policy but it is required for NDMP multiplexing:

Media multiplexing This value must be set to a number greater than one.

Required Clients tab options for an NDMP policy

In the client list, the following options are required for each client in an NDMP policy:

Hostname	Name of the NDMP host
Hardware and operating system	NDMP NDMP

Required backup selections options for an NDMP policy

The backup selections list must specify directories from the perspective of the NDMP host.

Two examples:

```
/home/dir1/  
/voll
```

The following backup selections capabilities are NOT supported for an NDMP policy:

- Wildcards in pathnames. For example, `/home/*` is an invalid entry.
- Individual file names. Only directory or volume names are allowed.
- Exclude list (because client software is not installed on the NDMP host). You can, however, exclude files by using the `SET` keyword.

See [“About environment variables in the backup selections list”](#) on page 56.

The `SET` option lets you exclude files on a backup. The format is vendor dependent; refer to the vendor’s documentation for more details on which variable can be passed and in what format.

About environment variables in the backup selections list

NDMP lets you use environment variables to pass configuration parameters to an NDMP host with each backup. NDMP environment variables can be one of the following types:

- Defined as optional by the NDMP protocol specification.
You can set these variables.
- Specific to an NDMP host vendor.
You can set these variables.
- Reserved for use by NetBackup:
FILESYSTEM
LEVEL
DIRECT
EXTRACT
ACL_START

In NetBackup, environment variables can be set within the backup selections list by specifying one or more `SET` directives.

Note: In the backup selections list, the `SET` directive must be the first in the list, followed by the file systems or volumes to back up.

To obtain up-to-date information on environment variables relating to particular NAS vendors, refer to the following:

See “[NDMP information on the Web](#)” on page 34.

In general, the syntax of a `SET` directive is as follows:

```
SET variable = value
```

Where *variable* is the name of the environment variable and *value* is the value that is assigned to it. The value can be enclosed in single or double quotes, and must be enclosed in quotes if it contains a space character. For example:

```
SET ABC = 22  
SET DEF = "hello there"  
SET type = tar
```

Setting a variable equal to no value unsets that variable. For example:

```
SET ABC =
```

Variables accumulate as the backup selections list is processed. For example, if backup selections contains the following entries:

```
/vol/vol1  
SET HIST = N  
/vol/vol2  
SET DEF = 20  
SET SAMPLE = all  
/vol/vol3
```

Directory `/vol/vol1` is backed up without any user-specified environment variables. The second directory (`/vol/vol2`) is backed up with the variable `HIST` set to `N`. The third directory (`/vol/vol3`) is backed up with all three of the environment variables set.

If an environment variable appears again later in the list, the value of this variable overrides the previous value of the variable.

The values that each backup uses are saved and provided to subsequent restores of the directory. The NDMP host may have some environment variables that are set internally and these are also saved for restores.

Backup types in a schedule for an NDMP policy

You can specify any of the following backup types in a schedule for an NDMP policy:

- Full
- Cumulative Incremental
- Differential Incremental

Specify **Override policy storage unit** only if the client of NetBackup (the NDMP host) has more than one storage unit and you want to use a specific storage unit for this schedule. In this case, the client must be the only client in this NDMP policy.

About enabling or disabling DAR

By default, NetBackup for NDMP is configured to use Direct Access Recovery (DAR) to restore files or directories. DAR is used somewhat differently for file restore than for directory restore.

The following table describes how DAR is used for file and directory restores.

Table 3-1 How DAR is used for file and directory restores

Type of restore	Description
File restore	For each restore of files (not of directories), NetBackup automatically determines if the use of DAR speeds up the restore. NetBackup uses DAR only when it results in a faster restore.
Directory restore	<p>For restore of directories, by default DAR is always used to restore a subdirectory but never used to restore the directory containing an entire image. For example, if <code>/vol/vol0</code> contains the entire image, and <code>/vol/vol0/dir1</code> is a subdirectory, DAR is used by default to restore <code>/vol/vol0/dir1</code>. But it is not used to restore <code>/vol/vol0</code>.</p> <p>For restore of subdirectories, NetBackup does not attempt to gauge the effectiveness of using DAR. Unless DAR is manually disabled, NetBackup always uses DAR to restore subdirectories.</p> <p>See “Disabling DAR for file and directory restores” on page 58.</p>

Note: You may have to disable DAR if you have problems with DAR and your NDMP host is an older computer or is not running the latest NAS OS version.

Disabling DAR for file and directory restores

This procedure disables DAR for both file and directory restores, for all NDMP policies.

To disable DAR

- 1 In the **NetBackup Administration Console**, expand **Host Properties** and click **Master Servers** or **Media Servers**.
- 2 Right-click the name of the server and select **Properties**.
- 3 Click **General Server**.
- 4 Uncheck the **Use direct access recovery for NDMP restores** box and click **Apply**.

This action disables DAR on all NDMP restores.

- 5 Click **OK**.

Disabling DAR for directory restores only

This procedure disables DAR for directory restores only. It leaves DAR enabled for individual file restores.

To disable DAR on restores of directories only, for all NDMP policies

- 1 Enter the string `NDMP_DAR_DIRECTORY_DISABLED` in the following file:

```
/usr/openv/netbackup/db/config/ndmp.cfg
```

- 2 To turn on directory DAR, remove (or comment out) the `NDMP_DAR_DIRECTORY_DISABLED` string from the `ndmp.cfg` file.

Setting up clustering

The following must be installed on each node of the cluster before configuring NetBackup for NDMP for clustering, :

- The NetBackup server
See the *NetBackup Installation Guide*.
- NetBackup for NDMP software.
See “[NetBackup for NDMP installation prerequisites](#)” on page 39.
For Windows servers, only the NetBackup for NDMP license key has to be installed.

To set up clustering

- 1 Configure NDMP-attached robots and drives. Then configure storage units and policies as in a normal, non-clustered environment:
 - You can use the NetBackup **Device Configuration Wizard**, or configure the devices manually.
See “[Authorizing NetBackup access to the NDMP host](#)” on page 44.
 - To use the same robotic libraries throughout a cluster, the robot numbers must be consistent. The **Device Configuration Wizard** attempts to ensure this configuration. If you configure robots manually, be sure to use the same robot number for a given robot, from one host to another in the cluster.
- 2 When you finish configuring devices and policies for NetBackup for NDMP, failover to the next node in the cluster and configure the drives and robots. Select the same robot number that you used when configuring the robot for the first node.

Post-installation changes

After NetBackup is configured in a clustered environment, most configuration information is available to all nodes in the cluster. The information is available by means of a shared hard drive. However, in the **NetBackup Administration Console**, if you make changes to **NetBackup Management > Host Properties**, they are not available on the shared drive. Such changes apply only to the active node. You must manually duplicate on each node the changes to **Host Properties** that are made on the active node. This action lets NetBackup perform exactly the same way in case of failover to another node.

Refer to the *NetBackup High Availability Guide* for assistance.

About testing an NDMP configuration

To test the configuration, run the backup and then restore some files. See the following topics:

- See [“Performing a manual backup of an NDMP policy”](#) on page 79.
- See [“Performing a restore from the server”](#) on page 80.
- See [“Additional troubleshooting information”](#) on page 83.

Configuring NDMP backup to NetBackup media servers (remote NDMP)

This chapter includes the following topics:

- [About remote NDMP](#)
- [Configuring NDMP backup to Media Manager storage units](#)

About remote NDMP

This topic describes how to configure NetBackup for NDMP to make backups to Media Manager storage units (remote NDMP). Only NDMP-specific steps are described.

Using remote NDMP, you can back up NDMP data to a configured drive in a Media Manager storage unit on a NetBackup media server. The drive can be used for both NDMP backups and for non-NDMP backups.

An added feature to remote NDMP is NDMP multiplexing. NDMP multiplexing works with remote NDMP. It concurrently writes multiple backup streams to the same storage device from the same client or different clients.

Figure 4-1 NDMP backup to a Media Manager storage unit

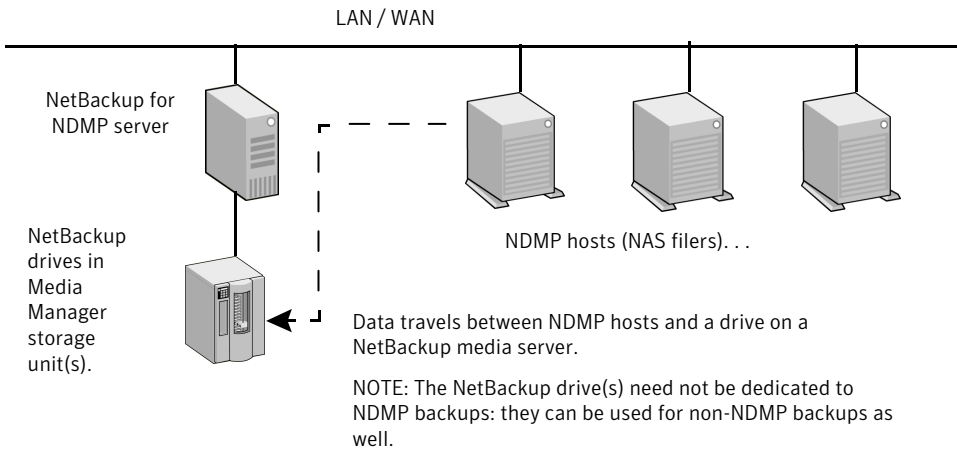

Configuring NDMP backup to Media Manager storage units

This section describes how to configure NDMP backups to Media Manager storage units.

To configure NDMP backups to Media Manager storage units

- 1 Authorize the NetBackup server to access the NDMP hosts you want to back up.

Do the following on the master server (not media server) if you plan to create snapshots using the Snapshot Client NAS_Snapshot method:

- Under **Media and Device Management > Credentials**, click on **NDMP Hosts**. Under the **Actions** menu, choose **New > New NDMP Host** to display the **Add NDMP Host** dialog box.
- Fill in the values.
See "[Authorizing NetBackup access to the NDMP host](#)" on page 44.
- Repeat the above for each NDMP host that the NetBackup server backs up.

- 2 Use the NetBackup **Device Configuration Wizard** to configure the drive(s) and robot(s).

Note the following:

- Do not use the "Configuring NDMP backup to NDMP-attached devices" topic in this guide. Configure the robots and drives as ordinary NetBackup devices, not as NDMP-attached devices.
See the *NetBackup Administrator's Guide, Volume I*.
 - Drives can be shared using the NetBackup Shared Storage Option (SSO). The drives can be shared as both NDMP drives and non-NDMP drives.
See "[About the Shared Storage Option \(SSO\)](#)" on page 73.
- 3 Create a Media Manager storage unit for the drive(s). The storage unit type must be Media Manager, not NDMP.
- Note the following for NDMP multiplexing:
- Select the **Enable Multiplexing** check box on the **New Storage Unit** menu.
 - Set the **Maximum streams per drive** entry to a value greater than one.
- For details on storage units, refer to the *NetBackup Administrator's Guide, Volume I*.
- 4 Create an NDMP-type policy. On the **New/Change Policy** display, be sure to specify the storage unit that was created in the previous step.
- Note the following for NDMP multiplexing:
- Set the **Media multiplexing** attribute on the **Add New Schedule** menu to a value greater than one.

Configuring NDMP direct copy

This chapter includes the following topics:

- [About NDMP DirectCopy](#)
- [Configuring NDMP DirectCopy](#)
- [Using NDMP DirectCopy to duplicate a backup image](#)

About NDMP DirectCopy

NDMP DirectCopy operates in the following environments:

- A NetBackup media server that is connected to a VTL that has access to a physical tape library. The steps for configuring NDMP DirectCopy are described in this topic.
- A NetBackup for the NDMP server that is connected to an NDMP host that has access to a tape library (no VTL). This NDMP backup environment is described in other topics of this guide. In this environment, no additional configuration is required for NDMP DirectCopy.

If your NDMP host and storage devices are correctly configured, NetBackup uses NDMP DirectCopy when you duplicate an NDMP backup that NetBackup had created.

Information about NDMP notes and limitations is available.

See “[NDMP DirectCopy notes and limitations](#)” on page 33.

Prerequisites for using NDMP DirectCopy

Note the following prerequisites for using NDMP DirectCopy:

- If your environment includes a VTL, the VTL must be installed and set up according to the vendor's instructions. The NetBackup Enterprise Disk Option license(s) are required. The Enterprise Disk Option license enables NDMP DirectCopy functionality.
- The VTL must have the NDMP capabilities needed to support NDMP DirectCopy.
- To make direct copies from one NDMP tape drive to another (no VTL), the NetBackup for NDMP license is required.

Configuring NDMP DirectCopy

Use the following procedure to configure NDMP DirectCopy from the backups that were made to a VTL.

To configure NDMP DirectCopy from the backups that were made to a VTL

- 1 Configure the VTL as an NDMP host. You can use the NetBackup **Device Configuration Wizard**, as follows. In the **NetBackup Administration Console**, click **Media and Device Management** and, in the right panel, click **Configure Storage Devices**.
 - In the **Device Hosts** dialog box of the wizard, choose the device host, then click **Change**.
 - In the **Change Device Host** dialog box, select **NDMP server** and click **OK**.
 - Click **Next**. The VTL appears in the **NDMP Host** window of the **NDMP Hosts** dialog box.
See "[Using the NetBackup Device Configuration Wizard](#)" on page 75.
- 2 Authorize NetBackup access to the VTL. Note that the VTL emulates an NDMP host.
See "[Authorizing NetBackup access to the NDMP host](#)" on page 44.
- 3 Configure the VTL as a robot, then configure one or more tape drives in a Media Manager storage unit.

You can use the NetBackup **Device Configuration Wizard**. Additional help configuring devices and Media Manager storage units is also available.

See the *NetBackup Administrator's Guide Volume I*.

- 4 Configure one or more tape drives in the VTL as Network Attached Storage devices, and create one or more NDMP storage units for the drives.

See [“Adding a drive”](#) on page 49.

See [“Adding NDMP storage units”](#) on page 52.

The drives can be the same as those that were selected in the previous step. NetBackup supports sharing of drives among media servers and NDMP hosts.

- 5 Configure one or more NDMP tape drives in the physical tape library, and add the drives to NDMP storage units. Use the same procedures as those mentioned in the previous step.

You can also use these drives in Media Manager storage units, if they are shared on a SAN.

Using NDMP DirectCopy to duplicate a backup image

NetBackup uses NDMP DirectCopy when you duplicate a backup image. To run a duplication, you can use any of the following:

- In the **NetBackup Administration Console**, expand **NetBackup Management > Catalog** and then, in the right pane, in the **Action** list box select the **Duplicate** action.

See [“Initiating NDMP DirectCopy with the NetBackup Administration Console”](#) on page 68.

- NetBackup Vault.
Refer to the *NetBackup Vault Administrator's Guide*.
- The `bpduplicate` command.
Refer to the *NetBackup Commands Guide*.

Requirements to use NDMP DirectCopy for image duplication

When NetBackup uses NDMP DirectCopy to duplicate an image, note the following:

- For the destination for the duplication, you must designate an NDMP storage unit in a VTL or in a physical tape library.
- An NDMP tape drive must be available to mount the source image. The NDMP tape drive can be one that was defined in the VTL, or it can be a physical tape drive in a tape library.

Setup instructions are available.

See [“About NDMP DirectCopy”](#) on page 65.

If these two requirements are met, NDMP DirectCopy is enabled. NetBackup copies the image directly to the designated storage unit without using media server I/O or network bandwidth.

NetBackup policy type for image duplication

You can duplicate an image that any NetBackup policy created; the policy need not be an NDMP policy.

See “[NDMP DirectCopy notes and limitations](#)” on page 33.

The backup can be made to a storage unit in the VTL or to a storage device that is attached to an NDMP host. You can then copy the backup directly to a tape drive using the NetBackup Duplicate feature, as follows.

Initiating NDMP DirectCopy with the NetBackup Administration Console

Use the following procedure to initiate NDMP DirectCopy.

To initiate NDMP DirectCopy

- 1 In the **NetBackup Administration Console**, expand **NetBackup Management > Catalog**.
- 2 Set up the search criteria for the image that you want to duplicate. Click **Search Now**.
- 3 Right-click the image(s) you want to duplicate and select **Duplicate** from the shortcut menu.

You must designate an NDMP storage unit as the destination for the duplication. Use the **Storage unit** field in the **Setup Duplication Variables** dialog box.

See “Duplicating backup images” in the *NetBackup Administrator’s Guide, Volume I*.

Remote NDMP and disk devices

This chapter includes the following topics:

- [About remote NDMP and disk devices](#)
- [Configuring remote NDMP](#)

About remote NDMP and disk devices

This remote NDMP feature involves backing up NAS data (Network Attached Storage) to a storage device that is configured on a NetBackup media server. NetBackup supports disk devices on the media server.

The following figure shows the main components for NDMP backup to disk storage.

Figure 6-1 NDMP backup to a storage unit on media server (remote NDMP)

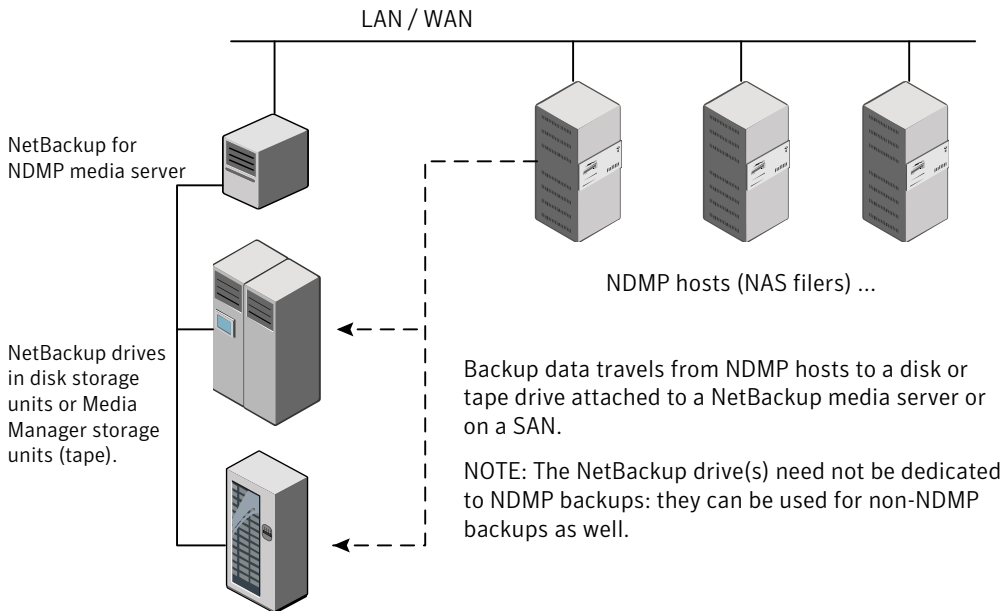

Configuring remote NDMP

Configure NetBackup to make backups to either disk storage or tape storage units that are attached to a NetBackup media server. Only NDMP-specific steps are described.

To configure NDMP backups to disk storage or tape storage units

- 1 Authorize the NetBackup server to access the NDMP hosts that you want to back up.

Do the following on the NetBackup media server:

- Expand **Media and Device Management > Credentials > NDMP Hosts**. Under the **Actions** menu, choose **New > New NDMP Host** to display the **Add NDMP Host** dialog box.
- Enter the name of the NDMP server (NAS filer) to back up. This NDMP host name is case-sensitive.

- Repeat the previous step for each NDMP host that the NetBackup server backs up.
 - If you plan to create snapshots using the Snapshot Client NAS_Snapshot method, do the previous step on the master server (not on the media server).
- 2 Use the NetBackup **Device Configuration Wizard** to configure devices for remote NDMP (disks, or tape drives and robots, on the media server).

Note the following:

- Do not use the device configuration procedure in “Configuring NDMP backup to NDMP-attached devices” in the *NetBackup for NDMP Administrator’s Guide*. Instead, configure the disk, robots, and drives the same way as the ordinary NetBackup devices are configured. See the *NetBackup Administrator’s Guide, Volume I*.
 - Tape drives can be shared using the Shared Storage Option (SSO) of NetBackup. The drives can be shared as both NDMP drives and non-NDMP drives. See “[About the Shared Storage Option \(SSO\)](#)” on page 73.
- 3 Create a disk or Media Manager storage unit for the drive(s). The storage unit type must be Disk or Media Manager, not NDMP.
For details on storage units, refer to the *NetBackup Administrator’s Guide, Volume I*.
 - 4 Create an NDMP-type policy. On the **New/Change Policy** display, be sure to specify the storage unit that was created at
See “About Creating an NDMP policy” in the *NetBackup for NDMP Administrator’s Guide*.

Using the Shared Storage Option (SSO)

This chapter includes the following topics:

- [About the Shared Storage Option \(SSO\)](#)
- [Setting up SSO overview](#)
- [Using the NetBackup Device Configuration Wizard](#)

About the Shared Storage Option (SSO)

The following figure shows a robotic library on a SAN that can share its drives between two NetBackup for NDMP servers and two NDMP hosts. Drive sharing requires a license for the Shared Storage Option. A SAN is not required.

Figure 7-1 NDMP backup using Shared Storage Option

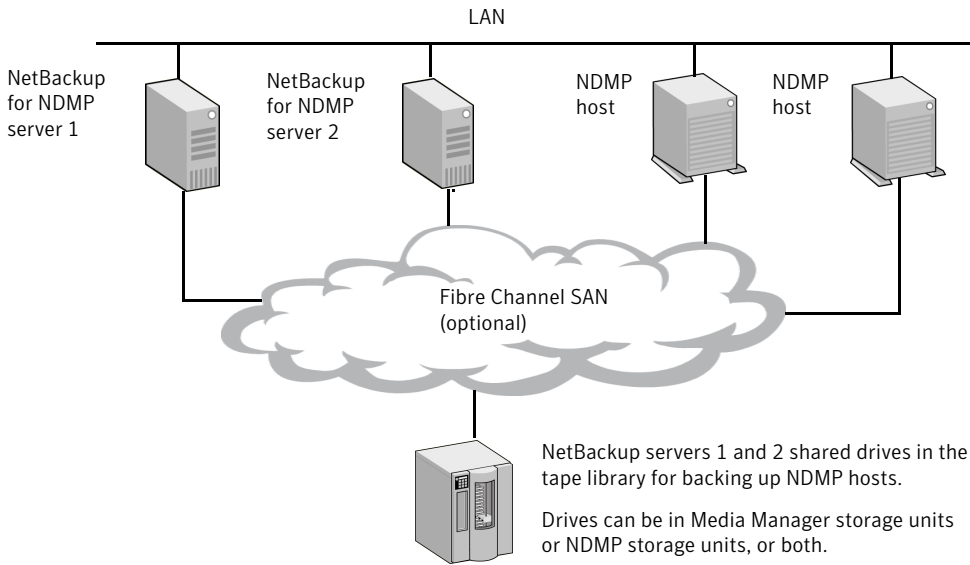

For each robot, either a NetBackup media server or an NDMP server (not both) can handle robotic control.

Setting up SSO overview

This overview includes an outline of the steps for setting up access to a drive that is shared between NDMP and NetBackup servers.

For a more complete discussion of SSO, refer to the *NetBackup Shared Storage Guide*.

This procedure assumes the following:

- That the prerequisites for SSO have been met, as described in the *NetBackup Shared Storage Guide*.
- That all physical devices, including the NDMP host, are correctly connected to the network.
- That NetBackup for NDMP supports the NDMP host.

A document that lists supported NAS systems is available.

See “[NDMP information on the Web](#)” on page 34.

The NetBackup NDMP Compatibility List indicates which versions of vendor software support SSO for NDMP. The NAS systems (hardware) do not provide the support; the proper software version provides it.

To set up an SSO

- 1 Configure NetBackup access to the NDMP host.

See “[Authorizing NetBackup access to the NDMP host](#)” on page 44.

- 2 Verify that the NDMP host can access the required robots and drives.

To verify NDMP host access to the required devices, run the following commands on a NetBackup media server that is authorized to access the host:

```
tpautoconf -verify ndmp_host_name  
tpautoconf -probe ndmp_host_name
```

The `-verify` option verifies that the NetBackup server can access the NDMP host. The `-probe` option lists the devices that are visible to the NDMP host.

- 3 From the **NetBackup Administration Console**, use the **Device Configuration Wizard** to configure the devices and storage units.

See “[Using the NetBackup Device Configuration Wizard](#)” on page 75.

An NDMP storage unit must be defined for each NDMP host that shares a drive. If all hosts have access to the shared drive(s), the **Device Configuration Wizard** can create these storage units automatically.

Using the NetBackup Device Configuration Wizard

The most convenient way to configure devices and storage units for NDMP hosts (with or without SSO) is to use the NetBackup **Device Configuration Wizard**.

To use the Device Configuration Wizard

- 1 In the **NetBackup Administration Console**, click **Configure Storage Devices** in the right panel to launch the **Device Configuration Wizard**.
- 2 Click **Next** on the **Welcome** window. The **Device Hosts** window appears.

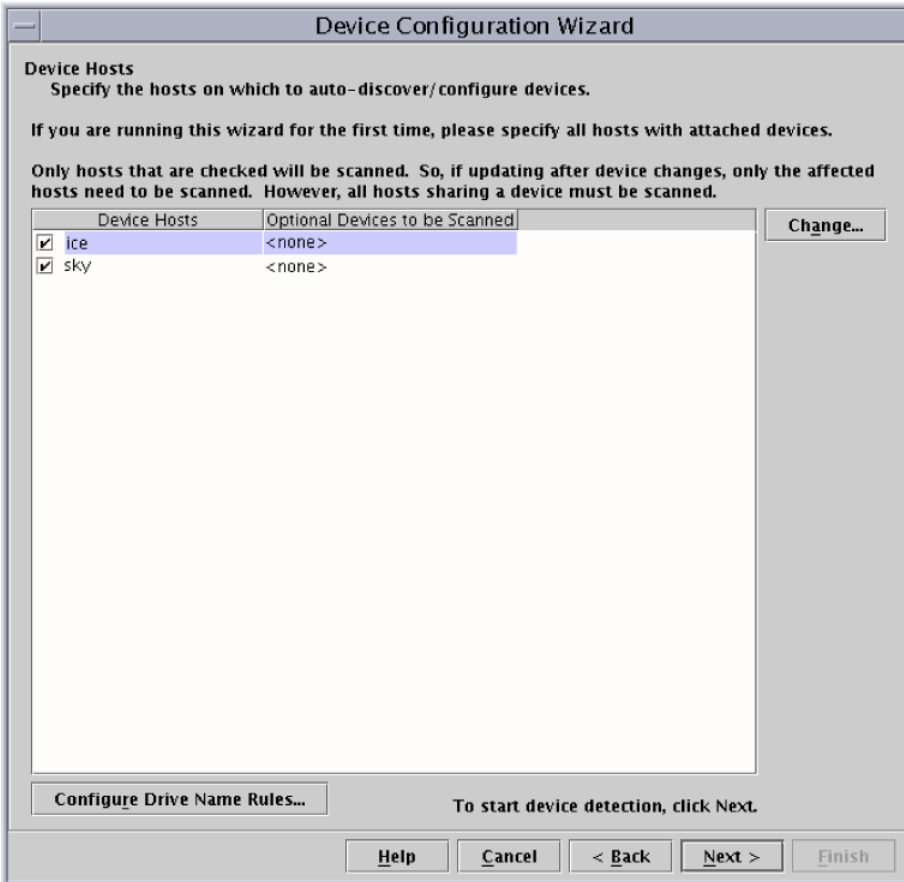

- 3 Under **Device Hosts**, place a check beside the NetBackup media server that accesses the NDMP host.
- 4 Click the server name to select it and click **Change**.

- 5 In the **Change Device Host** window, place a check beside **NDMP server**.



- 6 Click **OK**.
- 7 In the **Device Hosts** window, "NDMP" is now listed in the **Optional Devices to be Scanned** column for the media server.

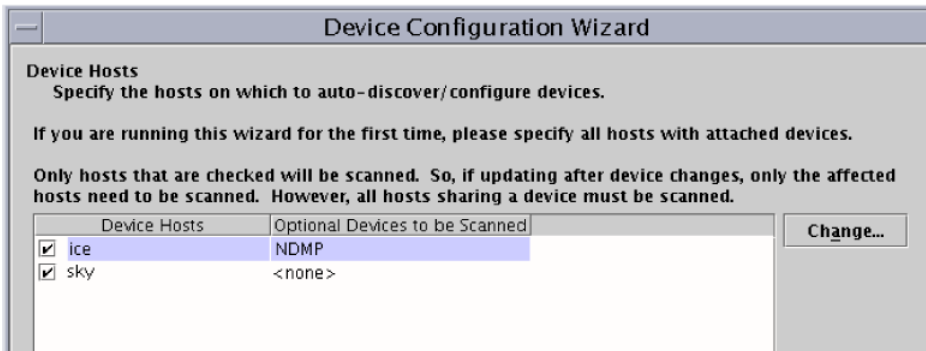

- 8 Click **Next** to continue.

- 9 In the **NDMP Hosts** screen that shows the NDMP host(s) where you can configure devices, click **Next** to configure the NDMP-attached devices.



- 10 Follow the screens in the wizard to complete the configuration.

Backup and restore procedures

This chapter includes the following topics:

- [About NDMP backup](#)
- [Automatic backup of an NDMP policy](#)
- [Performing a manual backup of an NDMP policy](#)
- [Performing a restore from the server](#)

About NDMP backup

Only the administrator can perform NDMP backups and restores on the NetBackup server (master or media). The NDMP protocol does not allow users to initiate a backup or restore; no NetBackup client software is installed on an NDMP host.

Automatic backup of an NDMP policy

Information is available to help you configure an NDMP policy and set up schedules for automatic, unattended backups.

See the *NetBackup Administrator's Guide, Volume I*.

Performing a manual backup of an NDMP policy

Only a NetBackup administrator can initiate an NDMP backup. The following procedure explains how to perform the backup using the **NetBackup Administration Console**.

For more information on the **NetBackup Administration Console**, see the *NetBackup Administrator's Guide, Volume I*.

To perform a manual backup of an NDMP policy

- 1 As administrator, start the **NetBackup Administration Console** on the NetBackup server in the following way:

On Windows, from the Windows **Start** menu, click **Programs > Symantec NetBackup > NetBackup Administration Console**.

On UNIX, enter the following:

```
/usr/opensv/netbackup/bin/jnbSA &
```

- 2 Click **Policies**.
- 3 Right-click the NDMP policy name and select **Manual Backup** from the pop-up menu.
- 4 In the **Manual Backup** dialog box, select a schedule and then select the clients (NDMP hosts) that you want to back up.

If you do not select any schedules, NetBackup uses the schedule with the highest retention level. If you do not select any clients, NetBackup backs up all configured NDMP hosts.
- 5 Click **OK** to start the backup.

Performing a restore from the server

The user-directed restores of files are not allowed, because no NetBackup client software is installed on an NDMP host.

The administrator can use the **Backup, Archive, and Restore** interface on a NetBackup server (master or media server) to restore files to the NDMP host from which they were backed up or to a different NDMP host.

For help with the restore procedure, see the NetBackup online Help in the **NetBackup Administration Console** or the *NetBackup Backup, Archive, and Restore Getting Started Guide*.

To perform a restore from the server

- 1 In the **Backup, Archive, and Restore** interface on a NetBackup server, click **Actions > Specify NetBackup Machines and Policy Type**.

- 2 For the server, select the NetBackup master server.

If your configuration has multiple master servers, specify the master server that has the policy for the NDMP host that you plan to restore. If the server name is not in the pull-down list, use **Edit Server List** to add it.

- 3 For the source and destination clients, select the appropriate NDMP (NAS) hosts.

The destination host must be an NDMP host compatible with the data format of the source. (The source and destination must be of the same NAS vendor type.)

Warning: An NDMP restore always overwrites existing files.

If the hosts that you want are not available in the pull-down menu, use **Edit Client List** to add the client.

- 4 In the policy type field, select **NDMP**.

Troubleshooting

This chapter includes the following topics:

- [Additional troubleshooting information](#)
- [NDMP operating notes and restrictions](#)
- [Notes on Direct Access Recovery \(DAR\)](#)
- [Types of NetBackup logs](#)
- [Using NetBackup logs](#)
- [NetBackup for NDMP troubleshooting suggestions](#)
- [Troubleshooting media and devices on Windows](#)
- [Troubleshooting media and devices on UNIX](#)
- [Troubleshooting NDMP DirectCopy](#)
- [Troubleshooting Direct Access Recovery \(DAR\)](#)
- [About testing a robot](#)

Additional troubleshooting information

For explanations of the NetBackup status codes, refer to the *NetBackup Troubleshooting Guide*.

Troubleshooting information is also available about particular NAS vendors.

See [“NDMP information on the Web”](#) on page 34.

NDMP operating notes and restrictions

Before you try to troubleshoot a suspected problem, review the following operating notes:

- A tape that was created on an NDMP storage unit is in backup format. It cannot be restored from a non-NDMP storage unit. If you duplicate an NDMP backup image, the new copy is still in backup format. It cannot be used for restores on a non-NDMP storage unit.
- In the Backup Selections list for an NDMP policy, you can include only directory paths. Wildcards and individual file names are not allowed.
- You cannot back up files where the path length is greater than 1024 characters.
- The NDMP protocol uses port 10000 for communication.
- On UNIX systems, the NetBackup `avrd` process uses ICMP (Internet Control Message Protocol) to ping NDMP hosts to verify network connectivity. This protocol is required for the NetBackup for NDMP product.
- If backup or restore jobs are running slowly, verify that the network interface cards (NIC) are set to full duplex. Half duplex often causes poor performance. For assistance viewing and resetting duplex mode for a particular NAS host, consult the documentation that the manufacturer provides. You may be able to use the `ifconfig` (or `ipconfig`) command, as explained in the *NetBackup Troubleshooting Guide*.
- Do not perform incremental backups of the same NDMP data from two different policies. Incremental backups performed by one of the policies may be incomplete, because NDMP filers perform level-based incrementals instead of time-based incrementals. Consider the following example:

Policy A does a full backup of `/vol/vol1` (level 0).

Policy B then does a full backup of `/vol/vol1` (level 0). The filer now considers the policy B backup to be the last full (level 0) backup of `/vol/vol1`.

Policy A does an incremental backup of `/vol/vol1` (level 1). The policy A incremental backup captures only the data that changed since the full backup that was done by policy B. The incremental backup misses any changes that occurred between the policy A full backup and the policy B full backup.

Notes on Direct Access Recovery (DAR)

Note the following points when using DAR:

- DAR can be used when restoring NetBackup 4.5GA or later backups. Starting with NetBackup 4.5GA, NetBackup stores the required DAR offset information on each backup.
- Backups must have been performed with the NetBackup catalog set to binary mode. If backups were made with the catalog set to ASCII mode, restores cannot use DAR. ASCII mode did not store the required DAR offset information on each backup. Note that all backups that were made before NetBackup 4.5 used ASCII catalog mode.

Note: Starting with NetBackup 6.0, all backups are in binary mode.

- To use DAR with NetBackup, the NDMP host you want to restore must support DAR. Some NDMP host vendors do not currently support DAR.

Types of NetBackup logs

NetBackup uses two types of logging, unified logging and legacy logging. Both logging types are described in the "Using Logs and Reports" topic in the *NetBackup Troubleshooting Guide*.

Note the following:

- All unified logs are written to `/usr/opensv/logs` (UNIX) or `install_path\logs` (Windows). Unlike legacy logging, you do not need to create logging directories.
- Use the `vxlogview` command to examine unified logs:
See "Using NetBackup logs" on page 85.
On UNIX: `/usr/opensv/netbackup/bin/vxlogview`
On Windows: `install_path\NetBackup\bin\vxlogview`
Refer to the *NetBackup Troubleshooting Guide* for assistance in using the `vxlogview` command.
See also the `vxlogview` man page or the *NetBackup Commands Guide*.

Using NetBackup logs

The following procedure describes how to use NetBackup logs.

Note: The legacy and unified logging files can consume a lot of disk space. Delete the log files when you are finished and set logging to a lower level of detail.

To use the NetBackup logs

- 1 In the **NetBackup Administration Console** in the left pane, expand **Host Properties > Media Servers**, and right-click on the server name in the right pane.
- 2 From the pop-up, select **Properties**, then click **Logging** and set the **Global logging level** to 5.

This increases logging detail to the highest level, for both unified logging and legacy logging.

- 3 Click **Apply** and then **OK**.
- 4 View the unified logging information in `/usr/opensv/logs` (UNIX) or `install_path\logs` (Windows) for the following processes:

`ndmpagent` (originator ID 134)

`ndmp` (originator ID 151)

`nbpem` (originator ID 116)

`nbjm` (originator ID 117)

`nbrb` (originator ID 118)

- 5 For `ndmpagent` logs, try the `vxlogview` command as follows:

```
/usr/opensv/netbackup/bin/vxlogview -I ndmpagent -d T,s,x,p
```

- 6 For `ndmp` logs, try the `vxlogview` command as follows:

```
/usr/opensv/netbackup/bin/vxlogview -I ndmp -d T,s,x,p
```

- 7 On the NetBackup for NDMP server, create `bptm`, `bpbrm`, and `ndmpagent` legacy debug log folders in the `/usr/opensv/netbackup/logs` directory (UNIX) or `install_path\NetBackup\logs` folder (Windows).

NetBackup writes legacy log files in these directories, if the directories exist.

NetBackup for NDMP troubleshooting suggestions

Try the following troubleshooting suggestions:

- Check the NetBackup All Log Entries report for information about the failed job.

- To verify that the appropriate services are running, use one of the following: the NetBackup Activity Monitor, the Windows control panel (on Windows systems), or the `bpps` command (UNIX systems).
- If NDMP host backups terminate with a status code of 154 (storage unit characteristics mismatch requests), the problem may be one of the following:
 - Verify that the NetBackup configuration is correct.
 - There may be a conflict between the policy type and storage unit type. (For example, if the policy type is Standard and the storage unit is of type NDMP.)
- If your NDMP backup fails with a status code of 99 (NDMP backup failure), no paths in your NDMP policy backup selections list were backed up. Check the NetBackup All Log Entries report for more information. A possible cause of this status is that none of the backup paths exist on the NDMP host.

NDMP backup levels

At the start of a debug log, you may see an entry titled `LEVEL`. This entry refers to an environment variable that NetBackup set based on the type of backup. Here is an example from a `bptm` log:

```
08:48:38.816 [22923] <2> write_data_ndmp: backup environment
values:
08:48:38.816 [22923] <2> write_data_ndmp: Environment 1:
TYPE=dump
08:48:38.816 [22923] <2> write_data_ndmp: Environment 2:
FILESYSTEM=/vol/vol0/2million
08:48:38.817 [22923] <2> write_data_ndmp: Environment 3:
PREFIX=/vol/vol0/2million
08:48:38.817 [22923] <2> write_data_ndmp: Environment 4: LEVEL=0
```

The NDMP backup level is modeled after UNIX dump levels. The backup level is a number in the range of 0 to 9.

An NDMP backup level of 0 is a full backup. A backup level greater than 0 is an incremental backup of all objects that were modified since the last backup of a lower level. For example, level 1 is a backup of all objects that were modified since the full backup (level 0). Level 3 is a backup of all objects that were modified since the last level 2 incremental.

Table 9-1 NetBackup backup types and corresponding NDMP backup levels

NetBackup backup types	NDMP backup levels
NetBackup Full	NDMP level 0

Table 9-1 NetBackup backup types and corresponding NDMP backup levels
(continued)

NetBackup backup types	NDMP backup levels
NetBackup Cumulative Incremental	NDMP level 1
NetBackup Differential Incremental	NDMP level (last level + 1, up to 9) never goes higher than 9

More information is available on environment variables.

See [“About environment variables in the backup selections list”](#) on page 56.

Troubleshooting media and devices on Windows

To troubleshoot media and devices on Windows, try the following:

- For legacy logging, enable debug logging by creating `reqlib` and `daemon` directories in the `install_path\Volmgr\debug` directory on the NetBackup for NDMP server.
- Check the Windows Event Viewer Application log for troubleshooting clues. For more information on the **Event Viewer logging** option, refer to the *NetBackup Troubleshooting Guide*.
- Use the **Activity Monitor** utility or the Windows control panel to verify that the **Media and Device Management** utilities are running.
- Drives can be unexpectedly set to the DOWN state.
This action is due to communication problems between `avrd` on the NetBackup for NDMP server and the NDMP server application on the NDMP host. Some possible causes for the communication problems are:
 - Network cable on the NDMP host was unplugged.
 - NIS (Network Information System) problems on the NetBackup for NDMP server (NDMP client).
 - The NDMP host was halted for too long.

Note: Whatever the cause, if the `avrd` connection to the NDMP host fails, the drive is set to DOWN. It is not automatically set to UP when the communication problem is corrected.

Troubleshooting media and devices on UNIX

To troubleshoot media and devices on UNIX, try the following:

- Ensure that the `syslogd` logs debug messages relating to `ltid` and other device processes.
 For more information on `syslogd`, refer to the *NetBackup Troubleshooting Guide*.
- Start `ltid` with the `-v` option. Check the system’s syslog for troubleshooting clues.
- Use `vmps` to make sure that the appropriate daemons are running.
- Drives can be unexpectedly set to the DOWN state. This action is due to communication problems between `avrd` on the NetBackup for NDMP server and the NDMP server application on the NDMP host.
 Further details are available.
 See “[Troubleshooting media and devices on Windows](#)” on page 88.

Troubleshooting NDMP DirectCopy

When NetBackup enables NDMP DirectCopy for a backup image duplication, the NetBackup progress log includes the message "NDMP DirectCopy should be used." If NDMP DirectCopy was not enabled for the duplication, no specific messages about NDMP DirectCopy are listed in the progress log. For detailed messages (such as why NDMP DirectCopy was not used), consult the legacy debug logs for the admin log or the `bptm` log.

Refer to the *NetBackup Troubleshooting Guide* for information on legacy NetBackup logs.

Troubleshooting Direct Access Recovery (DAR)

The following table lists the messages that may appear in the unified logs for `ndmpagent` (originator ID 134) on the NetBackup media server. These messages are also written to the progress log.

Table 9-2 DAR log messages

Message	Explanation
Data host does not support DAR recovery	The current NDMP host does not support DAR.

Table 9-2 DAR log messages (*continued*)

Message	Explanation
DAR disabled—continuing restore without DAR	DAR information is not available for the file.
DAR disabled—backup was performed before NB 4.5	The DAR feature can be used to restore the backups that NetBackup 4.5GA or later made. Starting with NetBackup 4.5GA, NetBackup stores the required DAR offset information on each backup. For pre-4.5GA NetBackup backups, restores cannot use DAR because the pre-4.5 versions did not store DAR offset information.
DAR disabled—NDMP host did not provide DAR info during backup	The backup was performed with an NDMP host version that does not support DAR. Ask the NDMP host vendor if a later NAS software version is available that supports DAR.
DAR disabled—Exceeded optimal DAR parameters for this image size	NetBackup determined that the restore would take longer with DAR than without it.
DAR disabled—Directory DAR not supported	DAR is automatically disabled when a restore job specifies a directory to restore. DAR can be used to restore files, but not to restoring directories.
DAR disabled by host parameters	DAR was disabled on the Master or Media Server Properties dialog box. See “About enabling or disabling DAR” on page 57.

About testing a robot

Depending on the type of robot, use the tests in the following table to exercise the robot.

Table 9-3 Robot types and tests

Robot type	Test
TLD	tlldtest
TL8	tl8test
TLH	tlhstest

Table 9-3 Robot types and tests (*continued*)

Robot type	Test
ACS	acstest

TL8 robot test example for Windows

To exercise the TL8 robot `c2t310` that the NDMP host `stripes` controls, use the following test and commands on Windows:

Note: The drive must be down before you perform this test, or `avrd` may interfere.

```
install_path\Volmgr\bin\tl8test -r stripes:c2t310 -d1 stripes:/dev/RMT/Ocbl
```

At the prompt, enter `?` for help information.

`inquiry` (Displays the vendor ID and product ID. If you get a UNIT ATTENTION message, try the `mode` command and then continue your testing.)

`s s` (Checks slot status.)

`s d` (Checks drive status.)

`m s3 d1` (Moves a tape from slot 3 to drive 1.)

`m d1 s3` (Moves the tape back to slot 3.)

TLD robot test example for UNIX

To exercise drive 1 in the TLD robot `c2t310` the NDMP host `stripes` controls, use the following commands on UNIX:

```
/usr/opensv/volmgr/bin/tldtest -r stripes:c2t310 -d1 stripes:/dev/RMT/Ocbl
```

At the prompt, enter `?` for help information.

`inquiry` (Displays the Vendor ID and Product ID. If you get a UNIT ATTENTION message, try the `mode` command and then continue your testing.)

`s s` (Checks slot status.)

`s d` (Checks drive status.)

`m s3 d1` (Moves a tape from slot 3 to drive 1.)

`unload d1` (Unloads the tape.)

`m d1 s3` (Moves the tape back to slot 3.)

TLH robot test example for UNIX

To exercise drive 1 in a TLH robot, use the following command on UNIX:

```
/usr/opensv/volmgr/bin/tlhtest -r /dev/lmcpo -d1 stripes:/dev/RMT/Ocbn
```

Note that a TLH robot cannot attach directly to the NDMP host; only a TLH drive can directly attach to the NDMP host.

At the prompt, enter ? for help information.

`inv` (Inventories the robot.)

`drstat` (Shows drive status.)

`m media_id drive_name` (Moves specified media to the specified drive.)

`dm drive_name` (Dismounts the tape.)

`unload drive_name` (Unloads the tape.)

Using scripts

This chapter includes the following topics:

- [About the NetBackup for NDMP scripts](#)
- [ndmp_start_notify script \(UNIX\)](#)
- [ndmp_start_notify.cmd script \(Microsoft Windows\)](#)
- [ndmp_end_notify script \(UNIX\)](#)
- [ndmp_end_notify.cmd script \(Microsoft Windows\)](#)
- [ndmp_start_path_notify script \(UNIX\)](#)
- [ndmp_start_path_notify.cmd script \(Microsoft Windows\)](#)
- [ndmp_end_path_notify script \(UNIX\)](#)
- [ndmp_end_path_notify.cmd script \(Microsoft Windows\)](#)
- [ndmp_moving_path_notify script \(UNIX\)](#)
- [ndmp_moving_path_notify.cmd script \(Microsoft Windows\)](#)

About the NetBackup for NDMP scripts

This topic explains how to customize the NDMP-specific notify scripts.

NetBackup for NDMP provides the following scripts (commands on Windows) for collecting information and providing notification of events.

Table 10-1 Scripts to run on the NetBackup for NDMP server

Scripts for UNIX	Scripts for Windows
ndmp_start_notify	ndmp_start_notify.cmd

Table 10-1 Scripts to run on the NetBackup for NDMP server (*continued*)

Scripts for UNIX	Scripts for Windows
ndmp_end_notify	ndmp_end_notify.cmd
ndmp_start_path_notify	ndmp_start_path_notify.cmd
ndmp_end_path_notify	ndmp_end_path_notify.cmd
ndmp_moving_path_notify	ndmp_moving_path_notify.cmd

The scripts are similar to those already included in your NetBackup server installation. To create the scripts on UNIX, copy the `bpstart_notify` and `bpend_notify` scripts from

```
/usr/opensv/netbackup/bin/goodies (UNIX)
```

to

```
/usr/opensv/netbackup/bin
```

on the NetBackup for NDMP server. Then rename the copied scripts and modify as needed.

On Windows, you must create the scripts from scratch.

ndmp_start_notify script (UNIX)

The UNIX scripts are provided as examples only. You must customize the scripts before using them. For example, the `-ne` value in the first `if` statement must be modified to reflect the number of passed parameters. For the `ndmp_start_notify` script, the `-ne` value must be set to 7.

On the UNIX media server, NetBackup calls the `ndmp_start_notify` script each time the client starts a backup operation. To use this script, create a script similar to

```
/usr/opensv/netbackup/bin/goodies/bpstart_notify
```

on the server, and copy it to

```
/usr/opensv/netbackup/bin/ndmp_start_notify
```

on the UNIX NetBackup for NDMP server. Then, modify the script and ensure that you have permission to run it.

Note: Before you use this script, make sure that you can run it by using `other` on the media server. Run `chmod 755 script_name`, where `script_name` is the name of the script.

The `ndmp_start_notify` script runs each time a backup starts and after the tape has been positioned. This script must exit with a status of 0 for the calling program to continue and for the backup to proceed. A nonzero status causes the client backup to exit with a status of `ndmp_start_notify failed`.

If the `/usr/opensv/netbackup/bin/ndmp_start_notify` script exists, it runs in the foreground. The `bptm` process that is on the NetBackup for NDMP server waits for it to complete before continuing. Any commands in the script that do not end with an `&` character run serially.

The server expects the client to respond with a `continue` message within the period of time that the NetBackup `CLIENT_READ_TIMEOUT` option on the server specifies.

The default for `CLIENT_READ_TIMEOUT` is 300. If the script needs more time than 300 seconds, increase the value to allow more time.

NetBackup passes the following parameters to the script:

Table 10-2 Script parameters for `ndmp_start_notify` (UNIX)

Parameter	Description
\$1	Specifies the name of the NDMP host.
\$2	Specifies the policy name from the NetBackup catalog.
\$3	Specifies the schedule name from the NetBackup catalog.
\$4	Specifies one of the following: FULL INCR (differential incremental) CINC (cumulative incremental)
\$5	Specifies the NetBackup status code for the operation.

For example:

```
ndmp_start_notify freddie cd4000s fulls FULL 0
ndmp_start_notify danr cd4000s incrementals INCR 0
ndmp_start_notify hare cd4000s fulls FULL 0
```

To create an `ndmp_start_notify` script for a specific policy or policy and schedule combination, create script files with a `.policyname` or `.policyname.schedulename` suffix. In the following two examples of script names, the policy is named `production` and the schedule is named `fulls`:

```
/usr/opensv/netbackup/bin/ndmp_start_notify.production
/usr/opensv/netbackup/bin/ndmp_start_notify.production.fulls
```

The first script affects all scheduled backups in the policy that is named `production`. The second script affects scheduled backups in the policy that is named `production` only when the schedule is named `fulls`.

Note: For a given backup, NetBackup uses only one `ndmp_start_notify` script and that is the one with the most specific name. For example, if there are both `ndmp_start_notify.production` and `ndmp_start_notify.production.fulls` scripts, NetBackup uses only `ndmp_start_notify.production.fulls`.

The `ndmp_start_notify` script can use the following environment variables:

```
BACKUPID
UNIXBACKUPTIME
BACKUPTIME
```

The NetBackup `bptm` process creates these variables. The following are examples of the strings that are available to the script for use in recording information about a backup:

```
BACKUPID=freddie_0857340526
UNIXBACKUPTIME=0857340526
BACKUPTIME=Sun Mar 2 16:08:46 1997
```

ndmp_start_notify.cmd script (Microsoft Windows)

When you use Windows NetBackup for NDMP media servers, you can create the batch scripts that provide notification whenever the client starts a backup. These scripts must reside on the media server in the following directory:

```
install_path\NetBackup\bin
```

where *install_path* is the directory where NetBackup is installed.

You can create `ndmp_start_notify` scripts that provide notification for all backups or only for backups of a specific policy or schedule. The `ndmp_start_notify` script runs each time a backup starts and after the tape is positioned.

To create a script that applies to all backups, name the script:

```
install_path\netbackup\bin\ndmp_start_notify.cmd
```

To create an `ndmp_start_notify` script that applies only to a specific policy or policy and schedule combination, add a `.policyname` or `.policyname.schedulename` suffix to the script name. The following are two examples:

- The following script applies only to a policy named `days`:

```
install_path\netbackup\bin\ndmp_start_notify.days.cmd
```

- The following script applies only to a schedule that is named `fulls`, which is in a policy named `days`:

```
install_path\netbackup\bin\ndmp_start_notify.days.fulls.cmd
```

The first script affects the scheduled backups in the policy named `days`. The second script affects the scheduled backups in the policy named `days` only when the schedule is named `fulls`.

For a given backup, NetBackup calls only one `ndmp_start_notify` script and checks for them in the following order:

```
ndmp_start_notify.policy.schedule.cmd
ndmp_start_notify.policy.cmd
ndmp_start_notify.cmd
```

For example, if there are both `ndmp_start_notify.policy.cmd` and `ndmp_start_notify.policy.schedule.cmd` scripts, NetBackup uses only the `ndmp_start_notify.policy.schedule.cmd` script.

Note: If you also use `ndmp_end_notify` scripts, they can provide a different level of notification than the `ndmp_start_notify` scripts. For example, if you had one of each, they could be `ndmp_start_notify.policy.cmd` and `ndmp_end_notify.policy.schedule.cmd`.

When the backup starts, NetBackup passes the following parameters to the script:

Table 10-3 Script parameters for `ndmp_start_notify.cmd` (Microsoft Windows)

Parameter	Description
%1	Specifies the name of the client from the NetBackup catalog.

Table 10-3 Script parameters for ndmp_start_notify.cmd (Microsoft Windows)
(continued)

Parameter	Description
%2	Specifies the policy name from the NetBackup catalog.
%3	Specifies the schedule name from the NetBackup catalog.
%4	Specifies one of the following: FULL INCR CINC
%5	Specifies the status of the operation is always 0 for bpstart_notify.
%6	Specifies the results file that NetBackup checks for a return code from the script. NetBackup uses %6 to pass the file name and then expects the script to create the file in the same directory as the script. If the script applies to a specific policy and schedule, the results file must be named <i>install_path\netbackup\bin\NDMP_START_NOTIFY_RES.policy.schedule</i> If the script applies to a specific policy, the results file must be named <i>install_path\netbackup\bin\NDMP_START_NOTIFY_RES.policy</i> If the script applies to all backups, the results file must be named <i>install_path\netbackup\bin\NDMP_START_NOTIFY_RES</i> An <code>echo 0> %6</code> statement is one way for the script to create the file. NetBackup deletes the existing results file before it calls the script. After the script runs, NetBackup checks the new results file for the status. The status must be 0 for the script to be considered successful. If the results file does not exist, NetBackup assumes that the script was successful.

The server expects the client to respond with a `continue` message within the period of time that the NetBackup `CLIENT_READ_TIMEOUT` option on the server specifies. The default is 300 seconds. If the script needs more than 300 seconds, increase the value to allow more time.

ndmp_end_notify script (UNIX)

The `ndmp_end_notify` script is run at the end of the backup. The backup does not wait for the script to complete.

Note: Before you use this script, make sure you can run it by using `other` on the media server. Run `chmod 755 script_name`, where `script_name` is the name of the script.

The UNIX scripts are provided as examples only. You must customize the scripts before using them. For example, the `-ne` value in the first `if` statement must be modified to reflect the number of passed parameters. For the `ndmp_end_notify` script, the `-ne` value must be set to 7.

For a UNIX media server, if you need notification whenever the NDMP host completes a backup, copy

```
/usr/opensv/netbackup/bin/goodies/bpend_notify
```

from the server, to

```
/usr/opensv/netbackup/bin/ndmp_end_notify
```

on the UNIX NetBackup for NDMP host. Then, modify the script and ensure that you have permission to run it.

The `ndmp_end_notify` script runs each time a backup completes.

NetBackup passes the following parameters to the `ndmp_end_notify` script:

Table 10-4 Script parameters for `ndmp_end_notify` (UNIX)

Parameter	Description
\$1	Specifies the name of the client from the NetBackup catalog.
\$2	Specifies the policy name from the NetBackup catalog.
\$3	Specifies the schedule name from the NetBackup catalog.
\$4	Specifies one of the following: FULL INCR (differential incremental) CINC (cumulative incremental)
\$5	Specifies the exit code from <code>bptm</code> .

For example:

```
ndmp_end_notify freddie cd4000s fulls FULL 0
ndmp_end_notify danr cd4000s incrementals INCR 73
```

To create an `ndmp_end_notify` script for a specific policy or policy and schedule combination, create script files with a `.policyname` or `.policyname.schedulename` suffix. In the following two examples of script names, the policy is named `production` and the schedule is named `fulls`:

```
/usr/opensv/netbackup/bin/ndmp_end_notify.production
/usr/opensv/netbackup/bin/ndmp_end_notify.production.fulls
```

The first script affects all scheduled backups in the policy that is named `production`. The second script affects scheduled backups in the policy that is named `production` only when the schedule is named `fulls`.

Note: For a given backup, NetBackup uses only one `ndmp_end_notify` script and that is the one with the most specific name. For example, if there are both `ndmp_end_notify.production` and `ndmp_end_notify.production.fulls` scripts, NetBackup uses only `ndmp_end_notify.production.fulls`.

The `ndmp_end_notify` script can use the following environment variables:

```
BACKUPID
UNIXBACKUPTIME
BACKUPTIME
```

The NetBackup `bptm` process creates these variables. The following are examples of the strings that are available to the script for use in recording information about a backup:

```
BACKUPID=freddie_0857340526
UNIXBACKUPTIME=0857340526
BACKUPTIME=Sun Mar 2 16:08:46 1997
```

ndmp_end_notify.cmd script (Microsoft Windows)

For Windows media servers, you can create the batch scripts that provide notification whenever the client completes a backup. These scripts must reside on the media server in the same directory as the NetBackup binaries:

```
install_path\NetBackup\bin
```

where *install_path* is the directory where NetBackup is installed.

You can create `ndmp_end_notify` scripts that provide notification for all backups or only for backups of a specific policy or schedule.

To create an `ndmp_end_notify` script that applies to all backups, name the script:

```
install_path\netbackup\bin\ndmp_end_notify.cmd
```

To create a script that applies only to a specific policy or policy and schedule combination, add a `.policyname` or `.policyname.schedulename` suffix to the script name. The following are two examples:

- The following script applies only to a policy named `days`:

```
install_path\netbackup\bin\ndmp_end_notify.days.cmd
```

- The following script applies only to a schedule that is named `fulls`, which is in a policy named `days`:

```
install_path\netbackup\bin\ndmp_end_notify.days.fulls.cmd
```

The first script affects all scheduled backups in the policy named `days`. The second script affects scheduled backups in the policy named `days` only when the schedule is named `fulls`.

For a given backup, NetBackup calls only one `ndmp_end_notify` script and checks for them in the following order:

```
ndmp_end_notify.policy.schedule.cmd
ndmp_end_notify.policy.cmd
ndmp_end_notify.cmd
```

For example, if there are both `ndmp_end_notify.policy.cmd` and `ndmp_end_notify.policy.schedule.cmd` scripts, NetBackup uses only `ndmp_end_notify.policy.schedule.cmd`.

Note: If you also use `ndmp_start_notify` scripts, they can provide a different level of notification than the `ndmp_end_notify` scripts. For example, if you had one of each, they could be `ndmp_start_notify.policy.cmd` and `ndmp_end_notify.policy.schedule.cmd`.

When the backup completes, NetBackup passes the following parameters to the script:

Table 10-5 Script parameters for `ndmp_end_notify.cmd` (Microsoft Windows)

Parameter	Description
%1	Specifies the name of the client from the NetBackup catalog.
%2	Specifies the policy name from the NetBackup catalog.

Table 10-5 Script parameters for ndmp_end_notify.cmd (Microsoft Windows)
(continued)

Parameter	Description
%3	Specifies the schedule name from the NetBackup catalog.
%4	Specifies one of the following: FULL INCR CINC
%5	Specifies the status of the operation. It is the same as the status sent to the NetBackup server. This status is 0 for successful backups and 1 for partially successful backups. If an error occurs, the status is the value associated with that error.
%6	<p>Note: The following file is not checked at the end of a backup.</p> <p>Specifies the results file that NetBackup checks for a return code from the script. NetBackup uses %6 to pass the file name and then expects the script to create the file in the same directory as the script.</p> <p>If the script applies to a specific policy and schedule, the results file must be named <i>install_path\netbackup\bin\NDMP_END_NOTIFY_RES.policy.schedule</i></p> <p>If the script applies to a specific policy, the results file must be named <i>install_path\netbackup\bin\NDMP_END_NOTIFY_RES.policy</i></p> <p>If the script applies to all backups, the results file must be named <i>install_path\netbackup\bin\NDMP_END_NOTIFY_RES</i></p> <p>An <code>echo 0 > %6</code> statement is one way for the script to create the file.</p> <p>NetBackup deletes the existing results file before it calls the script. After the script runs, NetBackup checks the new results file for the status. The status must be 0 for the script to be considered successful. If the results file does not exist, NetBackup assumes that the script was successful.</p>

ndmp_start_path_notify script (UNIX)

The UNIX scripts are provided as examples only. You must customize the scripts before using them. For example, the `-ne` value in the first if statement must be modified to reflect the number of passed parameters. For the `ndmp_start_path_notify` script, the `-ne` value must be set to 7.

To use this script, create a script similar to

```
/usr/opensv/netbackup/bin/goodies/bpstart_notify
```

on the server, and copy it to

```
/usr/opensv/netbackup/bin/ndmp_start_path_notify
```

on the UNIX NetBackup for NDMP server. Then, modify the script and ensure that you have permission to run it.

On the UNIX media server, the `ndmp_start_path_notify` script runs before the backup process is issued to the NAS machine. This script must exit with a status of 0 for the calling program to continue and for the backup to proceed. A nonzero status causes the client backup to exit with a status of 99 (NDMP backup failure).

Note: Before you use this script, make sure you can run it by using `other` on the media server. Run `chmod 755 script_name`, where `script_name` is the name of the script.

If the `/usr/opensv/netbackup/bin/ndmp_start_path_notify` script exists, it runs in the foreground. The `bptm` process on the NetBackup for NDMP server waits for it to complete before continuing. Any commands in the script that do not end with an `&` character run serially.

The server expects the client to respond with a `continue` message within the period of time that the NetBackup `CLIENT_READ_TIMEOUT` option on the server specifies.

The default for `CLIENT_READ_TIMEOUT` is 300. If the script needs more time than 300 seconds, increase the value to allow more time.

NetBackup passes the following parameters to the script:

Table 10-6 Script parameters for `ndmp_start_path_notify` (UNIX)

Parameter	Description
\$1	Specifies the name of the NDMP host.
\$2	Specifies the policy name from the NetBackup catalog.
\$3	Specifies the schedule name from the NetBackup catalog.
\$4	Specifies one of the following: FULL INCR (differential incremental) CINC (cumulative incremental)

Table 10-6 Script parameters for ndmp_start_path_notify (UNIX) (*continued*)

Parameter	Description
\$5	Specifies the NetBackup status code for the operation.
\$6	Not used.
\$7	Specifies the path being backed up.

For example:

```
ndmp_start_path_notify freddie cd4000s fulls FULL
ndmp_start_path_notify danr cd4000s incrementals INCR
ndmp_start_path_notify hare cd4000s fulls FULL
```

To create an `ndmp_start_path_notify` script for a specific policy or policy and schedule combination, create script files with a `.policyname` or `.policyname.schedulename` suffix. In the following two examples of script names, the policy is named `production` and the schedule is named `fulls`:

```
/usr/opensv/netbackup/bin/ndmp_start_path_notify.production
/usr/opensv/netbackup/bin/ndmp_start_path_notify.production.fulls
```

The first script affects all scheduled backups in the policy that is named `production`. The second script affects scheduled backups in the policy that is named `production` only when the schedule is named `fulls`.

Note: For a given backup, NetBackup uses only one `ndmp_start_path_notify` script and that is the one with the most specific name. For example, if there are both `ndmp_start_path_notify.production` and `ndmp_start_path_notify.production.fulls` scripts, NetBackup uses only `ndmp_start_path_notify.production.fulls`.

The `ndmp_start_path_notify` script can use the following environment variables:

```
BACKUPID
UNIXBACKUPTIME
BACKUPTIME
```

The NetBackup `bptm` process creates these variables. The following are examples of the strings that are available to the script for use in recording information about a backup:

```
BACKUPID=freddie_0857340526
UNIXBACKUPTIME=0857340526
BACKUPTIME=Sun Mar 2 16:08:46 1997
```

ndmp_start_path_notify.cmd script (Microsoft Windows)

For Windows media servers, you can create the batch scripts that provide notification before the backup process is issued to the NAS machine. These scripts must reside on the media server in the same directory as the NetBackup binaries:

```
install_path\NetBackup\bin
```

where *install_path* is the directory where NetBackup is installed.

You can create `ndmp_start_path_notify` scripts that provide notification for all backups or only for backups of a specific policy or schedule.

To create an `ndmp_start_path_notify` script that applies to all backups, name the script:

```
install_path\netbackup\bin\ndmp_start_path_notify.cmd
```

To create a script that applies only to a specific policy or policy and schedule combination, add a `.policyname` or `.policyname.schedulename` suffix to the script name. The following are two examples:

- The following script applies only to a policy named `days`:

```
install_path\netbackup\bin\ndmp_start_path_notify.days.cmd
```

- The following script applies only to a schedule that is named `fulls`, which in a policy named `days`:

```
install_path\netbackup\bin\ndmp_start_path_notify.days.fulls.cmd
```

The first script affects all scheduled backups in the policy named `days`. The second script affects scheduled backups in the policy named `days` only when the schedule is named `fulls`.

For a given backup, NetBackup calls only one `ndmp_start_path_notify` script and checks for them in the following order:

```
ndmp_start_path_notify.policy.schedule.cmd
ndmp_start_path_notify.policy.cmd
ndmp_start_path_notify.cmd
```

ndmp_start_path_notify.cmd script (Microsoft Windows)

For example, if there are both `ndmp_start_path_notify.policy.cmd` and `ndmp_start_path_notify.policy.schedule.cmd` scripts, NetBackup uses only `ndmp_start_path_notify.policy.schedule.cmd`.

Note: If you also use `ndmp_start_notify` scripts, they can provide a different level of notification than the `ndmp_start_path_notify` scripts. For example, if you had one of each, they could be `ndmp_start_notify.policy.cmd` and `ndmp_start_path_notify.policy.schedule.cmd`.

When the backup starts, NetBackup passes the following parameters to the script:

Table 10-7 Script parameters for `ndmp_start_path_notify.cmd` (Microsoft Windows)

Parameter	Description
%1	Specifies the name of the client from the NetBackup catalog.
%2	Specifies the policy name from the NetBackup catalog.
%3	Specifies the schedule name from the NetBackup catalog.
%4	Specifies one of the following: FULL INCR CINC
%5	Specifies the status of the operation. It is the same as the status sent to the NetBackup server. This status is 0 for successful backups and 1 for partially successful backups. If an error occurs, the status is the value associated with that error.

Table 10-7 Script parameters for ndmp_start_path_notify.cmd (Microsoft Windows) (continued)

Parameter	Description
%6	<p>Specifies the results file that NetBackup checks for a return code from the script. NetBackup uses %6 to pass the file name and then expects the script to create the file in the same directory as the script.</p> <p>If the script applies to a specific policy and schedule, the results file must be named <code>install_path\netbackup\bin\NDMP_START_PATH_NOTIFY_RES.policy.schedule</code></p> <p>If the script applies to a specific policy, the results file must be named <code>install_path\netbackup\bin\NDMP_START_PATH_NOTIFY_RES.policy</code></p> <p>If the script applies to all backups, the results file must be named <code>install_path\netbackup\bin\NDMP_START_PATH_NOTIFY_RES</code></p> <p>An <code>echo 0> %6</code> statement is one way for the script to create the file.</p> <p>NetBackup deletes the existing results file before it calls the script. After the script runs, NetBackup checks the new results file for the status. The status must be 0 for the script to be considered successful. If the results file does not exist, NetBackup assumes that the script was successful.</p>
%7	Pathname being backed up.

ndmp_end_path_notify script (UNIX)

The UNIX scripts are provided as examples only. You must customize the scripts before using them. For example, the `-ne` value in the first if statement must be modified to reflect the number of passed parameters. For the `ndmp_end_path_notify` script, the `-ne` value must be set to 7.

Note: Before you use this script, make sure you can run it by using `other` on the media server. Run `chmod 755 script_name`, where `script_name` is the name of the script.

For a UNIX media server, if you need notification whenever the NDMP host completes a backup, copy

```
/usr/opensv/netbackup/bin/goodies/bpend_notify
```

from the server, to

```
/usr/opensv/netbackup/bin/ndmp_end_path_notify
```

on the UNIX NetBackup for NDMP host. Then, modify the script and ensure that you have permission to run it.

The `ndmp_end_path_notify` script runs after the NAS machine has informed NetBackup that it has completed sending data.

NetBackup passes the following parameters to the `ndmp_end_notify` script:

Table 10-8 Script parameters for `ndmp_end_path_notify` (UNIX)

Parameter	Description
\$1	Specifies the name of the client from the NetBackup catalog.
\$2	Specifies the policy name from the NetBackup catalog.
\$3	Specifies the schedule name from the NetBackup catalog.
\$4	Specifies one of the following: FULL INCR (differential incremental) CINC (cumulative incremental)
\$5	Specifies the exit code from <code>bptm</code> .
\$6	Not used.
\$7	Specifies the path being backed up.

For example:

```
ndmp_end_path_notify freddie cd4000s fulls FULL 0
ndmp_end_path_notify danr cd4000s incrementals INCR 73
```

To create an `ndmp_end_path_notify` script for a specific policy or policy and schedule combination, create script files with a `.policyname` or `.policyname.schedulename` suffix. In the following two examples of script names, the policy is named `production` and the schedule is named `fulls`:

```
/usr/opensv/netbackup/bin/ndmp_end_path_notify.production
/usr/opensv/netbackup/bin/ndmp_end_path_notify.production.fulls
```

The first script affects all scheduled backups in the policy that is named `production`. The second script affects scheduled backups in the policy that is named `production` only when the schedule is named `fulls`.

Note: For a given backup, NetBackup uses only one `ndmp_end_path_notify` script and that is the one with the most specific name. For example, if there are both `ndmp_end_path_notify.production` and `ndmp_end_path_notify.production.fulls` scripts, NetBackup uses only `ndmp_end_path_notify.production.fulls`.

The `ndmp_end_path_notify` script can use the following environment variables:

```
BACKUPID
UNIXBACKUPTIME
BACKUPTIME
```

The NetBackup `bptm` process creates these variables. The following are examples of the strings that are available to the script for use in recording information about a backup:

```
BACKUPID=freddie_0857340526
UNIXBACKUPTIME=0857340526
BACKUPTIME=Sun Mar 2 16:08:46 1997
```

ndmp_end_path_notify.cmd script (Microsoft Windows)

For Windows media servers, you can create the batch scripts that provide notification whenever the client is finished writing to tape. These scripts must reside on the media server in the same directory as the NetBackup binaries:

```
install_path\NetBackup\bin
```

where *install_path* is the directory where NetBackup is installed.

You can create `ndmp_end_path_notify` scripts that provide notification for all backups or only for backups of a specific policy or schedule.

To create an `ndmp_end_path_notify` script that applies to all backups, name the script:

```
install_path\netbackup\bin\ndmp_end_path_notify.cmd
```

To create a script that applies only to a specific policy or policy and schedule combination, add a `.policyname` or `.policyname.schedulename` suffix to the script name. The following are two examples:

- The following script applies only to a policy named `days`:

```
install_path\netbackup\bin\ndmp_end_path_notify.days.cmd
```

- The following script applies only to a schedule that is named `fulls`, which is in a policy named `days`:

```
install_path\netbackup\bin\ndmp_end_path_notify.days.fulls.  
cmd
```

The first script affects all scheduled backups in the policy named `days`. The second script affects scheduled backups in the policy named `days` only when the schedule is named `fulls`.

For a given backup, NetBackup calls only one `ndmp_end_path_notify` script and checks for them in the following order:

```
ndmp_end_path_notify.policy.schedule.cmd  
ndmp_end_path_notify.policy.cmd  
ndmp_end_path_notify.cmd
```

For example, if there are both `ndmp_end_path_notify.policy.cmd` and `ndmp_end_path_notify.policy.schedule.cmd` scripts, NetBackup uses only `ndmp_end_path_notify.policy.schedule.cmd`.

Note: If you also use `ndmp_end_notify` scripts, they can provide a different level of notification than the `ndmp_end_path_notify` scripts. For example, if you had one of each, they could be `ndmp_end_notify.policy.cmd` and `ndmp_end_path_notify.policy.schedule.cmd`.

When the backup completes, NetBackup passes the following parameters to the script:

Table 10-9 Script parameters for `ndmp_end_path_notify.cmd` (Microsoft Windows)

Parameter	Description
%1	Specifies the name of the client from the NetBackup catalog.
%2	Specifies the policy name from the NetBackup catalog.
%3	Specifies the schedule name from the NetBackup catalog.

Table 10-9 Script parameters for ndmp_end_path_notify.cmd (Microsoft Windows) (*continued*)

Parameter	Description
%4	<p>Specifies one of the following:</p> <p>FULL INCR CINC</p>
%5	<p>Specifies the status of the operation. It is the same as the status sent to the NetBackup server. This status is 0 for successful backups and 1 for partially successful backups. If an error occurs, the status is the value associated with that error.</p>
%6	<p>Note: The following file is not checked when using ndmp_end_path_notify.</p> <p>Specifies the results file that NetBackup checks for a return code from the script. NetBackup uses %6 to pass the file name and then expects the script to create the file in the same directory as the script.</p> <p>If the script applies to a specific policy and schedule, the results file must be named</p> <pre>install_path\netbackup\bin\NDMP_END_PATH_NOTIFY_RES.policy.schedule</pre> <p>If the script applies to a specific policy, the results file must be named</p> <pre>install_path\netbackup\bin\NDMP_END_PATH_NOTIFY_RES.policy</pre> <p>If the script applies to all backups, the results file must be named</p> <pre>install_path\netbackup\bin\NDMP_END_PATH_NOTIFY_RES</pre> <p>An <code>echo 0 > %6</code> statement is one way for the script to create the file.</p> <p>NetBackup deletes the existing results file before it calls the script. After the script runs, NetBackup checks the new results file for the status. The status must be 0 for the script to be considered successful. If the results file does not exist, NetBackup assumes that the script was successful.</p>
%7	<p>Specifies the pathname being backed up.</p>

ndmp_moving_path_notify script (UNIX)

The UNIX scripts are provided as examples only. You must customize the scripts before using them. For example, the `-ne` value in the first if statement must be modified to reflect the number of passed parameters. For the `ndmp_moving_path_notify` script, the `-ne` value must be set to 7.

To use this script, create a script similar to

```
/usr/opensv/netbackup/bin/goodies/bpstart_notify
```

on the server, and copy it to

```
/usr/opensv/netbackup/bin/ndmp_moving_path_notify
```

on the UNIX NetBackup for NDMP server. Then, modify the script and ensure that you have permission to run it.

On UNIX media servers, the `ndmp_moving_path_notify` script runs after the backup process sends data to NetBackup.

Note: Before you use this script, make sure you can run it using other on the media server. Run `chmod 755 script_name`, where *script_name* is the name of the script.

If the `/usr/opensv/netbackup/bin/ndmp_moving_path_notify` script exists, it runs in the foreground. The `bptm` process that is on the NetBackup for NDMP server waits for it to complete before continuing. Any commands in the script that do not end with an `&` character run serially.

The server expects the client to respond with a `continue` message within the period of time that the NetBackup `CLIENT_READ_TIMEOUT` option on the server specifies.

The default for `CLIENT_READ_TIMEOUT` is 300 seconds. If the script needs more than 300 seconds, increase the value to allow more time.

NetBackup passes the following parameters to the script:

Table 10-10 Script parameters for `ndmp_moving_path_notify` (UNIX)

Parameter	Description
\$1	Specifies the name of the NDMP host.
\$2	Specifies the policy name from the NetBackup catalog.
\$3	Specifies the schedule name from the NetBackup catalog
\$4	Specifies one of the following: FULL INCR (differential incremental) CINC (cumulative incremental)
\$5	Specifies the NetBackup status code for the operation.
\$6	Not used.

Table 10-10 Script parameters for ndmp_moving_path_notify (UNIX) (*continued*)

Parameter	Description
\$7	Specifies the path being backed up.

For example:

```
ndmp_moving_path_notify freddie cd4000s fulls FULL
ndmp_moving_path_notify danr cd4000s incrementals INCR
ndmp_moving_path_notify hare cd4000s fulls FULL
```

To create an `ndmp_moving_path_notify` script for a specific policy or policy and schedule combination, create script files with a `.policyname` or `.policyname.schedulename` suffix. In the following two examples of script names, the policy is named `production` and the schedule is named `fulls`:

```
/usr/opensv/netbackup/bin/ndmp_moving_path_notify.production
/usr/opensv/netbackup/bin/ndmp_moving_path_notify.production.fulls
```

The first script affects all scheduled backups in the policy that is named `production`. The second script affects scheduled backups in the policy that is named `production` only when the schedule is named `fulls`.

Note: For a given backup, NetBackup uses only one `ndmp_moving_path_notify` script and that is the one with the most specific name. For example, if there are both `ndmp_moving_path_notify.production` and `ndmp_moving_path_notify.production.fulls` scripts, NetBackup uses only `ndmp_moving_path_notify.production.fulls`.

The `ndmp_moving_path_notify` script can use the following environment variables:

```
BACKUPID
UNIXBACKUPTIME
BACKUPTIME
```

The NetBackup `bptm` process creates these variables. The following are examples of the strings that are available to the script for use in recording information about a backup:

```
BACKUPID=freddie_0857340526
UNIXBACKUPTIME=0857340526
BACKUPTIME=Sun Mar 2 16:08:46 1997
```

ndmp_moving_path_notify.cmd script (Microsoft Windows)

For Windows media servers, you can create the batch scripts that provide notification whenever the NAS machine starts sending data. These scripts must reside on the media server in the same directory as the NetBackup binaries:

```
install_path\NetBackup\bin
```

where *install_path* is the directory where NetBackup is installed.

You can create `ndmp_moving_path_notify` scripts that provide notification for all backups or only for backups of a specific policy or schedule.

To create an `ndmp_moving_path_notify` script that applies to all backups, name the script:

```
install_path\netbackup\bin\ndmp_moving_path_notify.cmd
```

To create a script that applies only to a specific policy or policy and schedule combination, add a `.policyname` or `.policyname.schedulename` suffix to the script name. The following are two examples:

- The following script applies only to a policy named `days`:

```
install_path\netbackup\bin\ndmp_moving_path_notify.days.cmd
```

- The following script applies only to a schedule that is named `fulls`, which is in a policy named `days`:

```
install_path\netbackup\bin\ndmp_moving_path_notify.days.fulls.cmd
```

The first script affects all scheduled backups in the policy named `days`. The second script affects scheduled backups in the policy named `days` only when the schedule is named `fulls`.

For a given backup, NetBackup calls only one `ndmp_moving_path_notify` script and checks for them in the following order:

```
ndmp_moving_path_notify.policy.schedule.cmd  
ndmp_moving_path_notify.policy.cmd  
ndmp_moving_path_notify.cmd
```

For example, if there are both `ndmp_moving_path_notify.policy.cmd` and `ndmp_moving_path_notify.policy.schedule.cmd` scripts, NetBackup uses only `ndmp_moving_path_notify.policy.schedule.cmd`.

Note: If you also use `ndmp_start_notify` scripts, they can provide a different level of notification than the `ndmp_moving_path_notify` scripts. For example, if you had one of each, they could be `ndmp_start_notify.policy.cmd` and `ndmp_moving_path_notify.policy.schedule.cmd`.

When the backup starts, NetBackup passes the following parameters to the script.

Table 10-11 Script parameters for `ndmp_moving_path_notify.cmd` (Microsoft Windows)

Parameter	Description
%1	Specifies the name of the client from the NetBackup catalog.
%2	Specifies the policy name from the NetBackup catalog.
%3	Specifies the schedule name from the NetBackup catalog.
%4	Specifies one of the following: FULL INCR CINC
%5	Specifies the status of the operation. It is the same as the status sent to the NetBackup server. This status is 0 for successful backups and 1 for partially successful backups. If an error occurs, the status is the value associated with that error.

Table 10-11 Script parameters for ndmp_moving_path_notify.cmd (Microsoft Windows) *(continued)*

Parameter	Description
%6	<p>Note: The following is not checked when using <code>ndmp_moving_path_notify</code>.</p> <p>Specifies the results file that NetBackup checks for a return code from the script. NetBackup uses %6 to pass the file name and then expects the script to create the file in the same directory as the script.</p> <p>If the script applies to a specific policy and schedule, the results file must be named <code>install_path\netbackup\bin\NDMP_END_NOTIFY_RES.policy.schedule</code></p> <p>If the script applies to a specific policy, the results file must be named <code>install_path\netbackup\bin\NDMP_END_NOTIFY_RES.policy</code></p> <p>If the script applies to all backups, the results file must be named <code>install_path\netbackup\bin\NDMP_END_NOTIFY_RES</code></p> <p>An <code>echo 0> %6</code> statement is one way for the script to create the file.</p> <p>NetBackup deletes the existing results file before it calls the script. After the script runs, NetBackup checks the new results file for the status. The status must be 0 for the script to be considered successful. If the results file does not exist, NetBackup assumes that the script was successful.</p>
%7	<p>Specifies the pathname being backed up.</p>

Index

Symbols

- 10000
 - port (used by NDMP) 84
- 3pc.conf file 34

A

- access
 - for three-way backups and remote NDMP 46
- acstest 91
- Activity Monitor utility 88
- Add Drive dialog 50, 53
- Add Robot dialog 49
- adding
 - drives 50
 - Media Manager storage unit 63
 - NDMP storage units 52
 - robots 46
 - volumes 52
- adding a robot
 - directly attached to an NDMP host 46
- assigning
 - tape drives to different hosts 22
- authorization
 - NDMP host access 44
 - NDMP user and password 44
- auto discovery of devices 13, 44, 75
- automatic backup
 - of an NDMP policy 79
- avrd 84

B

- backup
 - automatic 79
 - format 84
 - level (NDMP vs. NetBackup) 87
 - local vs. three-way 13, 16, 19, 26
 - manual
 - of NDMP policy 79
 - ndmp_end_notify script (UNIX) 99
 - ndmp_end_notify script (Windows) 100

backup (*continued*)

- ndmp_end_path_notify script (UNIX) 108
- ndmp_end_path_notify script (Windows) 109
- ndmp_moving_path_notify script (UNIX) 112
- ndmp_moving_path_notify script (Windows) 114
- ndmp_start_notify script (Windows) 96
- ndmp_start_path_notify script (UNIX) 103
- ndmp_start_path_notify script (Windows) 105
- overview 25
- procedure 79
- three-way
 - configuring for 46
 - to Media Manager storage units (remote NDMP) 20
 - types allowed 57
- backup levels
 - NDMP 87
- backup process
 - NDMP 25
- Backup Selections list 55
 - environment variables 56
- backup types
 - backup to Media Manager storage units (remote NDMP) 20
 - NDMP local backup 18
 - NDMP three-way backup 19

C

- changes
 - post-installation 60
- checking
 - device configuration 51
- clustering 14
 - setting up 59
- compatibility list
 - for NDMP 34
- configuration
 - add Media Manager storage unit 63
 - add NDMP storage unit 52
 - add volumes 52

- configuration (*continued*)
 - adding drives/robots 46
 - Backup Selections list 55
 - check devices 51
 - client list 55
 - drive
 - for NDMP-attached host 50
 - for clustering 59
 - general policy attributes 54
 - media and device management 46
 - policy storage unit 54
 - policy type 54
 - robot 47
 - schedules 54, 57
 - testing 60
- configure
 - NDMP DirectCopy 66
- configuring
 - NDMP-attached devices 44
 - remote NDMP 70
- control panel
 - Windows 88
- creating
 - NDMP policy 54

D

- DAR 14, 29
 - defined 15
 - how to turn on/off 57
 - troubleshooting 89
- DAR (Direct Access Recovery)
 - notes 84
- data mover 34
- Data Mover off-host backup method 36–37
- debug logs 86
- deinstallation
 - server 42
- Device Configuration Wizard 13, 44
 - using 75
- Device Monitor 51
- different client restore 16
- Direct Access Recovery (DAR) 29
- Direct Access Recovery (see DAR) 14, 84
- direct copy
 - NDMP 30, 89
- DirectCopy
 - NDMP 65
- directory restores
 - disabling DAR 59

- disabling DAR
 - for directory restores only 59
 - for file and directory restores 58
- Disk Option license 33
- drives
 - adding
 - for NDMP-attached host 50
 - configuring 46
- duplex mode and performance 84

E

- enabling or disabling
 - DAR 57
- Enterprise Disk Option
 - licensing 66
- environment variables
 - in Backup Selections list 56
- exclude
 - files
 - using SET directive 55
 - list
 - using 55

F

- fail over 59
- features
 - NetBackup for NDMP 12
- file and directory restores
 - disabling DAR 58
- file list 55
- file names (not allowed in Backup Selections list) 55, 84

H

- Hardware Compatibility List 34
- High Availability 14, 59
- host
 - NDMP 24

I

- ICMP protocol 84
- image duplication
 - NetBackup policy type 68
 - requirements 67
- initiating NDMP DirectCopy
 - with the NetBackup Administration Console 68
- installation
 - deinstallation 42

- installation *(continued)*
 - NetBackup for NDMP 39
 - prerequisites 39
- installing NDMP
 - on UNIX servers 40
- installing NetBackup for NDMP
 - on Windows servers 41
- instant recovery 13
- IPv6
 - address data connections 35

J

- jnbSA 80

L

- legacy logging 85
- LEVEL (NDMP backup) 87
- limitations
 - NDMP DirectCopy 33
- log directories 86, 88–89
- ltid
 - restarting 51

M

- manual backup
 - of an NDMP policy 79
- media and device management
 - configuration 46
- media and devices
 - troubleshooting 88
- media and devices on UNIX
 - troubleshooting 89
- media and devices on Windows
 - troubleshooting 88
- Media Manager
 - storage units 22
- mover.conf file 34
- multiplexing
 - NDMP 34

N

- NAS snapshot 13, 44, 62
- nbjm 86
- nbpem 86
- nbrb 86
- NDMP
 - access web info 34

NDMP *(continued)*

- backup 79
 - manual 79
- backup levels 87
- backup process 25
- client
 - definition of 15
- client type 55
- Data Mover off-host backup method 36–37
- direct copy 14, 30, 89
 - how to configure 66
 - licensing 66
 - VTL license 33
- DirectCopy 65
- host 24
 - definition of 15
- host, authorizing access 44
- IPv6 35
- IPv6 address data connections 35
- LEVEL
 - related to NetBackup backups 87
- Multiplexing 35
- multiplexing 34
 - definition of 16
- multiplexing general considerations 35
- operating notes and restrictions 84
- policy
 - attributes 54
 - clients 55
 - files 55
 - schedules 54, 57
- policy storage unit attribute
 - configuration 54
- policy type
 - configuration 54
 - overview 21
- protocol 15, 17, 84
- Replication Director support for 36
- restore 80
- restore process 27
- schedule 54
- server application
 - definition of 16
- storage unit
 - adding 52
 - definition of 16
- storage units 22
- to media server 15, 46, 54, 61
 - how to configure 62

- NDMP and disk devices
 - remote 69
 - NDMP backup
 - types 18
 - NDMP configuration
 - testing 60
 - NDMP DirectCopy
 - how to use 67
 - limitations 33
 - prerequisites 65
 - troubleshooting 89
 - without VTL 32
 - NDMP host
 - adding a robot directly attached to 46
 - NDMP information
 - on the Web 34
 - NDMP IPv6 35
 - general considerations 36
 - NDMP local backup 18
 - ndmp logging 86
 - NDMP Multiplexing 35
 - NDMP password and robot connection
 - verifying 52
 - NDMP policies 21
 - NDMP policy
 - automatic backup 79
 - backup types in a schedule 57
 - manual backup 79
 - required attributes 54
 - required client options 55
 - required files (backup selections) 55
 - schedules 54
 - NDMP three-way backup 19
 - NDMP to media server 13, 20
 - NDMP-attached devices
 - configuring 44
 - ndmp_end_notify script
 - UNIX 99
 - Windows 100
 - ndmp_end_notify script (UNIX) 98
 - ndmp_end_path_notify script
 - UNIX 108
 - Windows 109
 - ndmp_moving_path_notify script
 - UNIX 112
 - Windows 114
 - ndmp_start_notify script
 - Windows 96
 - ndmp_start_notify script (UNIX) 94
 - ndmp_start_path_notify script
 - Windows 105
 - ndmp_start_path_notify script (UNIX) 102
 - ndmpagent
 - legacy debug log 86
 - unified logging 86
 - NetBackup
 - logs 85
 - server 25
 - storage units 22
 - NetBackup Administration Console 80
 - initiating NDMP DirectCopy 68
 - NetBackup for NDMP
 - configuration 44
 - definition 12
 - features 12
 - installation 39
 - introduction 12
 - server
 - definition 15
 - terminology 14
 - troubleshooting 86
 - uninstalling 41
 - NetBackup logs
 - using 85
 - NetBackup policy type
 - for image duplication 68
 - network interface cards 84
 - NIC cards and full duplex 84
 - notification scripts 93
- O**
- off-host backup
 - with data mover 34
 - on demand storage unit 53
 - operating notes and restrictions
 - NDMP 84
 - Override policy storage unit
 - setting 57
 - overwriting files 81
- P**
- password
 - verifying 46, 52
 - path length limit 84
 - path-based history 14
 - peripherals (latest info on web) 34
 - ping 84

- Point in Time rollback restore 36
- point-in-time snapshots 13
- policies
 - NDMP 21
- policy
 - attributes 54
- port 10000 (used by NDMP) 84
- post-installation
 - changes 60
- prerequisites
 - for using NDMP DirectCopy 65
 - installation 39
- protocol
 - NDMP 17
- protocol supported (NDMP) 12, 44

R

- remote
 - NDMP and disk devices 69
- remote NDMP 61
 - backup 20
- required
 - client options for an NDMP policy 55
 - files (backup selections) for an NDMP policy 55
 - policy attributes for an NDMP policy 54
- requirements
 - to use NDMP DirectCopy for image duplication 67
- reserved environment variables 56
- restart
 - device manager 49
 - Media Manager device daemon 51
- restore
 - from the server 80
 - local vs. three-way 16, 19, 26
 - overview 28
 - overwriting files 81
 - procedure 80
 - three-way 28
 - to different client 16, 21
- restore process
 - NDMP 27
- restoring
 - Point in Time rollback 36
- restrictions
 - NetBackup for NDMP 84
- robot
 - adding 46
 - supported types 22

- robot (*continued*)
 - test device configuration 90
 - testing 90
- robot connection
 - verifying 52
- Robot Control Host
 - for volume 52
- robot test examples
 - TL8 91
 - TLD 91
 - TLH 92
- robots
 - configuring 46

S

- schedules 54
 - backup types for an NDMP policy 57
- script
 - ndmp_end_notify (UNIX) 98
 - ndmp_end_notify.cmd (Microsoft Windows) 100
 - ndmp_moving_path_notify (UNIX) 112
 - ndmp_moving_path_notify.cmd script (Microsoft Windows) 114
 - ndmp_start_notify (UNIX) 94
 - ndmp_start_notify.cmd (Microsoft Windows) 96
 - ndmp_start_path_notify (UNIX) 102
 - ndmp_start_path_notify.cmd (Microsoft Windows) 105
- scripts
 - notification 93
- server
 - NetBackup 25
- SET directive 56
- setting up
 - clustering 59
- Shared Storage Option (see SSO) 74
- Shared Storage Option (SSO)
 - introduction 73
- Snapshot Client 13
 - access web info 34
 - assistance 34
- snapshots 13
- SSO 13
 - configuration overview 74
- SSO, see Shared Storage Option 73
- storage devices
 - auto discovery 13, 44
- storage unit
 - adding 52

- storage unit *(continued)*
 - media manager type 61
 - NDMP type
 - overview 22
 - specify for NDMP policy 54
- storage units
 - Media Manager 22
 - NDMP 22
 - NetBackup 22
- support web site 34
- supported robots 22

T

- tape drives
 - assigning to different hosts 22
- tape libraries supported 22
- tape server 19
- terminology
 - NetBackup for NDMP 14
- testing
 - an NDMP configuration 60
 - robots 90
- testing configuration 60
- third-party copy device 34
- three-way backup 16
 - configuring for 46
- three-way backups and remote NDMP
 - access 46
- TL8 robot
 - test example for Windows 91
- tl8test 90
- TLD robot
 - test example for UNIX 91
- tldtest 90
- TLH robot
 - test example for UNIX 92
- tlhtest 90, 92
- tpautoconf 52, 75
- troubleshooting
 - additional information 83
 - DAR (Direct Access Recovery) 89
 - media and devices on UNIX 89
 - media and devices on Windows 88
 - NDMP DirectCopy 89
 - suggestions 86
- type
 - of backup allowed 57
 - of policy 54

- types
 - NDMP backup 18

U

- unified logging 85–86
- uninstalling
 - NetBackup for NDMP 41
- uninstalling NetBackup 42
- UNIX servers
 - NDMP installed on 40
- user-directed
 - backups and archives 21
 - not allowed 79
 - restores
 - not allowed 80
- using
 - Device Configuration Wizard 75
 - NDMP DirectCopy 67
 - NetBackup logs 85

V

- variables
 - environment 56
- vendors (latest info on) 34
- verifying
 - NDMP password and robot connection 52
- verifying NDMP password 46
- version supported (NDMP) 12, 44
- Virtual tape Library
 - see VTL 14
- volumes
 - adding 52
- VTL 14, 30, 65, 89
 - license 33
 - NDMP DirectCopy 32
- vxlogview 85

W

- web access
 - to NDMP info 34
 - to Snapshot Client info 34
- wildcards
 - in Backup Selections list 55, 84
- Windows control panel 88
- Windows servers
 - installing NetBackup for NDMP 41