

# PARTIAL DIFFERENTIAL EQUATIONS MA 3132 LECTURE NOTES

**B. Neta** Department of Mathematics  
Naval Postgraduate School  
Code MA/Nd  
Monterey, California 93943

March 14, 2006

© 1996 - Professor Beny Neta

# Contents

<b>1</b>	<b>Introduction and Applications</b>	<b>1</b>
1.1	Basic Concepts and Definitions . . . . .	1
1.2	Applications . . . . .	4
1.3	Conduction of Heat in a Rod . . . . .	5
1.4	Boundary Conditions . . . . .	7
1.5	A Vibrating String . . . . .	10
1.6	Boundary Conditions . . . . .	11
1.7	Diffusion in Three Dimensions . . . . .	13
<b>2</b>	<b>Classification and Characteristics</b>	<b>15</b>
2.1	Physical Classification . . . . .	15
2.2	Classification of Linear Second Order PDEs . . . . .	15
2.3	Canonical Forms . . . . .	19
2.3.1	Hyperbolic . . . . .	19
2.3.2	Parabolic . . . . .	22
2.3.3	Elliptic . . . . .	24
2.4	Equations with Constant Coefficients . . . . .	28
2.4.1	Hyperbolic . . . . .	28
2.4.2	Parabolic . . . . .	29
2.4.3	Elliptic . . . . .	29
2.5	Linear Systems . . . . .	32
2.6	General Solution . . . . .	33
<b>3</b>	<b>Method of Characteristics</b>	<b>37</b>
3.1	Advection Equation (first order wave equation) . . . . .	37
3.1.1	Numerical Solution . . . . .	42
3.2	Quasilinear Equations . . . . .	44
3.2.1	The Case $S = 0$ , $c = c(u)$ . . . . .	45
3.2.2	Graphical Solution . . . . .	46
3.2.3	Fan-like Characteristics . . . . .	49
3.2.4	Shock Waves . . . . .	50
3.3	Second Order Wave Equation . . . . .	58
3.3.1	Infinite Domain . . . . .	58
3.3.2	Semi-infinite String . . . . .	62
3.3.3	Semi Infinite String with a Free End . . . . .	65
3.3.4	Finite String . . . . .	68
3.3.5	Parallelogram Rule . . . . .	70
<b>4</b>	<b>Separation of Variables-Homogeneous Equations</b>	<b>73</b>
4.1	Parabolic equation in one dimension . . . . .	73
4.2	Other Homogeneous Boundary Conditions . . . . .	77
4.3	Eigenvalues and Eigenfunctions . . . . .	83

<b>5</b>	<b>Fourier Series</b>	<b>85</b>
5.1	Introduction . . . . .	85
5.2	Orthogonality . . . . .	86
5.3	Computation of Coefficients . . . . .	88
5.4	Relationship to Least Squares . . . . .	96
5.5	Convergence . . . . .	97
5.6	Fourier Cosine and Sine Series . . . . .	99
5.7	Term by Term Differentiation . . . . .	106
5.8	Term by Term Integration . . . . .	108
5.9	Full solution of Several Problems . . . . .	110
<b>6</b>	<b>Sturm-Liouville Eigenvalue Problem</b>	<b>120</b>
6.1	Introduction . . . . .	120
6.2	Boundary Conditions of the Third Kind . . . . .	127
6.3	Proof of Theorem and Generalizations . . . . .	131
6.4	Linearized Shallow Water Equations . . . . .	137
6.5	Eigenvalues of Perturbed Problems . . . . .	140
<b>7</b>	<b>PDEs in Higher Dimensions</b>	<b>147</b>
7.1	Introduction . . . . .	147
7.2	Heat Flow in a Rectangular Domain . . . . .	148
7.3	Vibrations of a rectangular Membrane . . . . .	151
7.4	Helmholtz Equation . . . . .	155
7.5	Vibrating Circular Membrane . . . . .	158
7.6	Laplace's Equation in a Circular Cylinder . . . . .	164
7.7	Laplace's equation in a sphere . . . . .	170
<b>8</b>	<b>Separation of Variables-Nonhomogeneous Problems</b>	<b>179</b>
8.1	Inhomogeneous Boundary Conditions . . . . .	179
8.2	Method of Eigenfunction Expansions . . . . .	182
8.3	Forced Vibrations . . . . .	186
8.3.1	Periodic Forcing . . . . .	187
8.4	Poisson's Equation . . . . .	190
8.4.1	Homogeneous Boundary Conditions . . . . .	190
8.4.2	Inhomogeneous Boundary Conditions . . . . .	192
<b>9</b>	<b>Fourier Transform Solutions of PDEs</b>	<b>195</b>
9.1	Motivation . . . . .	195
9.2	Fourier Transform pair . . . . .	196
9.3	Heat Equation . . . . .	200
9.4	Fourier Transform of Derivatives . . . . .	204
9.5	Fourier Sine and Cosine Transforms . . . . .	208
9.6	Fourier Transform in 2 Dimensions . . . . .	214

<b>10 Green's Functions</b>	<b>220</b>
10.1 Introduction . . . . .	220
10.2 One Dimensional Heat Equation . . . . .	220
10.3 Green's Function for Sturm-Liouville Problems . . . . .	224
10.4 Dirac Delta Function . . . . .	230
10.5 Nonhomogeneous Boundary Conditions . . . . .	233
10.6 Fredholm Alternative And Modified Green's Functions . . . . .	235
10.7 Green's Function For Poisson's Equation . . . . .	241
10.7.1 Nonhomogeneous Boundary Conditions . . . . .	242
10.7.2 Two Dimensional Infinite Domain . . . . .	243
10.7.3 Two Dimensional Bounded Domains . . . . .	244
10.8 Wave Equation on Infinite Domains . . . . .	247
10.9 Heat Equation on Infinite Domains . . . . .	255
10.10 Green's Function for the Wave Equation on a Cube . . . . .	260
<b>11 Laplace Transform</b>	<b>270</b>
11.1 Introduction . . . . .	270
11.2 Solution of Wave Equation . . . . .	275
<b>12 Finite Differences</b>	<b>281</b>
12.1 Taylor Series . . . . .	281
12.2 Finite Differences . . . . .	282
12.3 Irregular Mesh . . . . .	284
12.4 Thomas Algorithm . . . . .	285
12.5 Methods for Approximating PDEs . . . . .	286
12.5.1 Undetermined coefficients . . . . .	286
12.5.2 Integral Method . . . . .	287
12.6 Eigenpairs of a Certain Tridiagonal Matrix . . . . .	288
<b>13 Finite Differences</b>	<b>290</b>
13.1 Introduction . . . . .	290
13.2 Difference Representations of PDEs . . . . .	291
13.3 Heat Equation in One Dimension . . . . .	295
13.3.1 Implicit method . . . . .	297
13.3.2 DuFort Frankel method . . . . .	297
13.3.3 Crank-Nicholson method . . . . .	298
13.3.4 Theta ( $\theta$ ) method . . . . .	300
13.3.5 An example . . . . .	300
13.4 Two Dimensional Heat Equation . . . . .	305
13.4.1 Explicit . . . . .	305
13.4.2 Crank Nicholson . . . . .	306
13.4.3 Alternating Direction Implicit . . . . .	306
13.5 Laplace's Equation . . . . .	307
13.5.1 Iterative solution . . . . .	310

13.6	Vector and Matrix Norms . . . . .	311
13.7	Matrix Method for Stability . . . . .	315
13.8	Derivative Boundary Conditions . . . . .	316
13.9	Hyperbolic Equations . . . . .	317
13.9.1	Stability . . . . .	317
13.9.2	Euler Explicit Method . . . . .	320
13.9.3	Upstream Differencing . . . . .	320
13.10	Inviscid Burgers' Equation . . . . .	324
13.10.1	Lax Method . . . . .	325
13.10.2	Lax Wendroff Method . . . . .	326
13.11	Viscous Burgers' Equation . . . . .	328
13.11.1	FTCS method . . . . .	330
13.11.2	Lax Wendroff method . . . . .	332
<b>14</b>	<b>Numerical Solution of Nonlinear Equations</b>	<b>334</b>
14.1	Introduction . . . . .	334
14.2	Bracketing Methods . . . . .	334
14.3	Fixed Point Methods . . . . .	336
14.4	Example . . . . .	338
14.5	Appendix . . . . .	340

# List of Figures

1	A rod of constant cross section . . . . .	6
2	Outward normal vector at the boundary . . . . .	7
3	A thin circular ring . . . . .	8
4	A string of length $L$ . . . . .	10
5	The forces acting on a segment of the string . . . . .	10
6	The families of characteristics for the hyperbolic example . . . . .	21
7	The family of characteristics for the parabolic example . . . . .	24
8	Characteristics $t = \frac{1}{c}x - \frac{1}{c}x(0)$ . . . . .	38
9	2 characteristics for $x(0) = 0$ and $x(0) = 1$ . . . . .	40
10	Solution at time $t = 0$ . . . . .	40
11	Solution at several times . . . . .	41
12	$u(x_0, 0) = f(x_0)$ . . . . .	44
13	Graphical solution . . . . .	46
14	The characteristics for Example 4 . . . . .	49
15	The solution of Example 4 . . . . .	50
16	Intersecting characteristics . . . . .	51
17	Sketch of the characteristics for Example 6 . . . . .	53
18	Shock characteristic for Example 5 . . . . .	55
19	Solution of Example 5 . . . . .	55
20	Domain of dependence . . . . .	59
21	Domain of influence . . . . .	60
22	The characteristic $x - ct = 0$ divides the first quadrant . . . . .	62
23	The solution at P . . . . .	64
24	Reflected waves reaching a point in region 5 . . . . .	68
25	Parallelogram rule . . . . .	69
26	Use of parallelogram rule to solve the finite string case . . . . .	70
27	$\sinh x$ and $\cosh x$ . . . . .	75
28	Graph of $f(x) = x$ and the $N^{th}$ partial sums for $N = 1, 5, 10, 20$ . . . . .	90
29	Graph of $f(x)$ given in Example 3 and the $N^{th}$ partial sums for $N = 1, 5, 10, 20$ . . . . .	91
30	Graph of $f(x)$ given in Example 4 . . . . .	92
31	Graph of $f(x)$ given by example 4 ( $L = 1$ ) and the $N^{th}$ partial sums for $N = 1, 5, 10, 20$ . Notice that for $L = 1$ all cosine terms and odd sine terms vanish, thus the first term is the constant .5 . . . . .	93
32	Graph of $f(x)$ given by example 4 ( $L = 1/2$ ) and the $N^{th}$ partial sums for $N = 1, 5, 10, 20$ . . . . .	94
33	Graph of $f(x)$ given by example 4 ( $L = 2$ ) and the $N^{th}$ partial sums for $N = 1, 5, 10, 20$ . . . . .	94
34	Sketch of $f(x)$ given in Example 5 . . . . .	98
35	Sketch of the periodic extension . . . . .	98
36	Sketch of the Fourier series . . . . .	98
37	Sketch of $f(x)$ given in Example 6 . . . . .	99
38	Sketch of the periodic extension . . . . .	99

39	Graph of $f(x) = x^2$ and the $N^{th}$ partial sums for $N = 1, 5, 10, 20$ . . . . .	101
40	Graph of $f(x) =  x $ and the $N^{th}$ partial sums for $N = 1, 5, 10, 20$ . . . . .	102
41	Sketch of $f(x)$ given in Example 10 . . . . .	103
42	Sketch of the Fourier sine series and the periodic odd extension . . . . .	103
43	Sketch of the Fourier cosine series and the periodic even extension . . . . .	103
44	Sketch of $f(x)$ given by example 11 . . . . .	104
45	Sketch of the odd extension of $f(x)$ . . . . .	104
46	Sketch of the Fourier sine series is <u>not</u> continuous since $f(0) \neq f(L)$ . . . . .	104
47	Graphs of both sides of the equation in case 1 . . . . .	127
48	Graphs of both sides of the equation in case 3 . . . . .	128
49	Bessel functions $J_n, n = 0, \dots, 5$ . . . . .	160
50	Bessel functions $Y_n, n = 0, \dots, 5$ . . . . .	161
51	Bessel functions $I_n, n = 0, \dots, 4$ . . . . .	167
52	Bessel functions $K_n, n = 0, \dots, 3$ . . . . .	167
53	Legendre polynomials $P_n, n = 0, \dots, 5$ . . . . .	173
54	Legendre functions $Q_n, n = 0, \dots, 3$ . . . . .	174
55	Rectangular domain . . . . .	191
56	Plot $G(\omega)$ for $\alpha = 2$ and $\alpha = 5$ . . . . .	196
57	Plot $g(x)$ for $\alpha = 2$ and $\alpha = 5$ . . . . .	197
58	Plot of the error function $erf(x)$ . . . . .	202
59	Domain for Laplace's equation example . . . . .	210
60	Representation of a continuous function by unit pulses . . . . .	230
61	Several impulses of unit area . . . . .	230
62	Irregular mesh near curved boundary . . . . .	284
63	Nonuniform mesh . . . . .	284
64	Rectangular domain with a hole . . . . .	290
65	Polygonal domain . . . . .	290
66	Amplification factor for simple explicit method . . . . .	295
67	Uniform mesh for the heat equation . . . . .	296
68	Computational molecule for explicit solver . . . . .	296
69	Computational molecule for implicit solver . . . . .	297
70	Amplification factor for several methods . . . . .	298
71	Computational molecule for Crank Nicholson solver . . . . .	299
72	Numerical and analytic solution with $r = .5$ at $t = .025$ . . . . .	301
73	Numerical and analytic solution with $r = .5$ at $t = .5$ . . . . .	301
74	Numerical and analytic solution with $r = .51$ at $t = .0255$ . . . . .	302
75	Numerical and analytic solution with $r = .51$ at $t = .255$ . . . . .	303
76	Numerical and analytic solution with $r = .51$ at $t = .459$ . . . . .	303
77	Numerical (implicit) and analytic solution with $r = 1$ . at $t = .5$ . . . . .	304
78	Computational molecule for the explicit solver for 2D heat equation . . . . .	306
79	Uniform grid on a rectangle . . . . .	308
80	Computational molecule for Laplace's equation . . . . .	308
81	Amplitude versus relative phase for various values of Courant number for Lax Method . . . . .	318

82	Amplification factor modulus for upstream differencing . . . . .	323
83	Relative phase error of upstream differencing . . . . .	324
84	Solution of Burgers' equation using Lax method . . . . .	326
85	Solution of Burgers' equation using Lax Wendroff method . . . . .	328
86	Stability of FTCS method . . . . .	331
87	Solution of example using FTCS method . . . . .	332



Overview MA 3132  
PDEs

1. Definitions
2. Physical Examples
3. Classification/Characteristic Curves
4. Method of Characteristics
  - (a) 1<sup>st</sup> order linear hyperbolic
  - (b) 1<sup>st</sup> order quasilinear hyperbolic
  - (c) 2<sup>nd</sup> order linear (constant coefficients) hyperbolic
5. Separation of Variables Method
  - (a) Fourier series
  - (b) One dimensional heat & wave equations (homog., 2<sup>nd</sup> order, constant coefficients)
  - (c) Two dimensional elliptic (non homog., 2<sup>nd</sup> order, constant coefficients) for both cartesian and polar coordinates.
  - (d) Sturm Liouville Theorem to get results for nonconstant coefficients
  - (e) Two dimensional heat and wave equations (homog., 2<sup>nd</sup> order, constant coefficients) for both cartesian and polar coordinates
  - (f) Helmholtz equation
  - (g) generalized Fourier series
  - (h) Three dimensional elliptic (nonhomog, 2<sup>nd</sup> order, constant coefficients) for cartesian, cylindrical and spherical coordinates
  - (i) Nonhomogeneous heat and wave equations
  - (j) Poisson's equation
6. Solution by Fourier transform (infinite domain only!)
  - (a) One dimensional heat equation (constant coefficients)
  - (b) One dimensional wave equation (constant coefficients)
  - (c) Fourier sine and cosine transforms
  - (d) Double Fourier transform

# 1 Introduction and Applications

This section is devoted to basic concepts in partial differential equations. We start the chapter with definitions so that we are all clear when a term like linear partial differential equation (PDE) or second order PDE is mentioned. After that we give a list of physical problems that can be modelled as PDEs. An example of each class (parabolic, hyperbolic and elliptic) will be derived in some detail. Several possible boundary conditions are discussed.

## 1.1 Basic Concepts and Definitions

Definition 1. A partial differential equation (PDE) is an equation containing partial derivatives of the dependent variable.

For example, the following are PDEs

$$u_t + cu_x = 0 \tag{1.1.1}$$

$$u_{xx} + u_{yy} = f(x, y) \tag{1.1.2}$$

$$\alpha(x, y)u_{xx} + 2u_{xy} + 3x^2u_{yy} = 4e^x \tag{1.1.3}$$

$$u_x u_{xx} + (u_y)^2 = 0 \tag{1.1.4}$$

$$(u_{xx})^2 + u_{yy} + a(x, y)u_x + b(x, y)u = 0 . \tag{1.1.5}$$

Note: We use subscript to mean differentiation with respect to the variables given, e.g.  $u_t = \frac{\partial u}{\partial t}$ . In general we may write a PDE as

$$F(x, y, \dots, u, u_x, u_y, \dots, u_{xx}, u_{xy}, \dots) = 0 \tag{1.1.6}$$

where  $x, y, \dots$  are the independent variables and  $u$  is the unknown function of these variables. Of course, we are interested in solving the problem in a certain domain  $D$ . A solution is a function  $u$  satisfying (1.1.6). From these many solutions we will select the one satisfying certain conditions on the boundary of the domain  $D$ . For example, the functions

$$\begin{aligned} u(x, t) &= e^{x-ct} \\ u(x, t) &= \cos(x - ct) \end{aligned}$$

are solutions of (1.1.1), as can be easily verified. We will see later (section 3.1) that the general solution of (1.1.1) is any function of  $x - ct$ .

Definition 2. The order of a PDE is the order of the highest order derivative in the equation. For example (1.1.1) is of first order and (1.1.2) - (1.1.5) are of second order.

Definition 3. A PDE is linear if it is linear in the unknown function and all its derivatives with coefficients depending only on the independent variables.

For example (1.1.1) - (1.1.3) are linear PDEs.

Definition 4. A PDE is nonlinear if it is not linear. A special class of nonlinear PDEs will be discussed in this book. These are called quasilinear.

Definition 5. A PDE is quasilinear if it is linear in the highest order derivatives with coefficients depending on the independent variables, the unknown function and its derivatives of order lower than the order of the equation.

For example (1.1.4) is a quasilinear second order PDE, but (1.1.5) is not.

We shall primarily be concerned with linear second order PDEs which have the general form

$$A(x, y)u_{xx} + B(x, y)u_{xy} + C(x, y)u_{yy} + D(x, y)u_x + E(x, y)u_y + F(x, y)u = G(x, y) . \quad (1.1.7)$$

Definition 6. A PDE is called homogeneous if the equation does not contain a term independent of the unknown function and its derivatives.

For example, in (1.1.7) if  $G(x, y) \equiv 0$ , the equation is homogenous. Otherwise, the PDE is called inhomogeneous.

Partial differential equations are more complicated than ordinary differential ones. Recall that in ODEs, we find a particular solution from the general one by finding the values of arbitrary constants. For PDEs, selecting a particular solution satisfying the supplementary conditions may be as difficult as finding the general solution. This is because the general solution of a PDE involves an arbitrary function as can be seen in the next example. Also, for linear homogeneous ODEs of order  $n$ , a linear combination of  $n$  linearly independent solutions is the general solution. This is not true for PDEs, since one has an infinite number of linearly independent solutions.

### Example

Solve the linear second order PDE

$$u_{\xi\eta}(\xi, \eta) = 0 \quad (1.1.8)$$

If we integrate this equation with respect to  $\eta$ , keeping  $\xi$  fixed, we have

$$u_{\xi} = f(\xi)$$

(Since  $\xi$  is kept fixed, the integration constant may depend on  $\xi$ .)

A second integration yields (upon keeping  $\eta$  fixed)

$$u(\xi, \eta) = \int f(\xi)d\xi + G(\eta)$$

Note that the integral is a function of  $\xi$ , so the solution of (1.1.8) is

$$u(\xi, \eta) = F(\xi) + G(\eta) . \quad (1.1.9)$$

To obtain a particular solution satisfying some boundary conditions will require the determination of the two functions  $F$  and  $G$ . In ODEs, on the other hand, one requires two constants. We will see later that (1.1.8) is the one dimensional wave equation describing the vibration of strings.

## Problems

1. Give the order of each of the following PDEs

- a.  $u_{xx} + u_{yy} = 0$
- b.  $u_{xxx} + u_{xy} + a(x)u_y + \log u = f(x, y)$
- c.  $u_{xxx} + u_{xyyy} + a(x)u_{xxy} + u^2 = f(x, y)$
- d.  $u u_{xx} + u_{yy}^2 + e^u = 0$
- e.  $u_x + cu_y = d$

2. Show that

$$u(x, t) = \cos(x - ct)$$

is a solution of

$$u_t + cu_x = 0$$

3. Which of the following PDEs is linear? quasilinear? nonlinear? If it is linear, state whether it is homogeneous or not.

- a.  $u_{xx} + u_{yy} - 2u = x^2$
- b.  $u_{xy} = u$
- c.  $u u_x + x u_y = 0$
- d.  $u_x^2 + \log u = 2xy$
- e.  $u_{xx} - 2u_{xy} + u_{yy} = \cos x$
- f.  $u_x(1 + u_y) = u_{xx}$
- g.  $(\sin u_x)u_x + u_y = e^x$
- h.  $2u_{xx} - 4u_{xy} + 2u_{yy} + 3u = 0$
- i.  $u_x + u_x u_y - u_{xy} = 0$

4. Find the general solution of

$$u_{xy} + u_y = 0$$

(Hint: Let  $v = u_y$ )

5. Show that

$$u = F(xy) + x G\left(\frac{y}{x}\right)$$

is the general solution of

$$x^2 u_{xx} - y^2 u_{yy} = 0$$

## 1.2 Applications

In this section we list several physical applications and the PDE used to model them. See, for example, Fletcher (1988), Haltiner and Williams (1980), and Pedlosky (1986).

For the heat equation (parabolic, see definition 7 later).

$$u_t = ku_{xx} \quad (\text{in one dimension}) \quad (1.2.1)$$

the following applications

1. Conduction of heat in bars and solids
2. Diffusion of concentration of liquid or gaseous substance in physical chemistry
3. Diffusion of neutrons in atomic piles
4. Diffusion of vorticity in viscous fluid flow
5. Telegraphic transmission in cables of low inductance or capacitance
6. Equilization of charge in electromagnetic theory.
7. Long wavelength electromagnetic waves in a highly conducting medium
8. Slow motion in hydrodynamics
9. Evolution of probability distributions in random processes.

Laplace's equation (elliptic)

$$u_{xx} + u_{yy} = 0 \quad (\text{in two dimensions}) \quad (1.2.2)$$

or Poisson's equation

$$u_{xx} + u_{yy} = S(x, y) \quad (1.2.3)$$

is found in the following examples

1. Steady state temperature
2. Steady state electric field (voltage)
3. Inviscid fluid flow
4. Gravitational field.

Wave equation (hyperbolic)

$$u_{tt} - c^2u_{xx} = 0 \quad (\text{in one dimension}) \quad (1.2.4)$$

appears in the following applications

1. Linearized supersonic airflow
2. Sound waves in a tube or a pipe
3. Longitudinal vibrations of a bar
4. Torsional oscillations of a rod
5. Vibration of a flexible string
6. Transmission of electricity along an insulated low-resistance cable
7. Long water waves in a straight canal.

Remark: For the rest of this book when we discuss the parabolic PDE

$$u_t = k \nabla^2 u \tag{1.2.5}$$

we always refer to  $u$  as temperature and the equation as the heat equation. The hyperbolic PDE

$$u_{tt} - c^2 \nabla^2 u = 0 \tag{1.2.6}$$

will be referred to as the wave equation with  $u$  being the displacement from rest. The elliptic PDE

$$\nabla^2 u = Q \tag{1.2.7}$$

will be referred to as Laplace's equation (if  $Q = 0$ ) and as Poisson's equation (if  $Q \neq 0$ ). The variable  $u$  is the steady state temperature. Of course, the reader may want to think of any application from the above list. In that case the unknown  $u$  should be interpreted depending on the application chosen.

In the following sections we give details of several applications. The first example leads to a parabolic one dimensional equation. Here we model the heat conduction in a wire (or a rod) having a constant cross section. The boundary conditions and their physical meaning will also be discussed. The second example is a hyperbolic one dimensional wave equation modelling the vibrations of a string. We close with a three dimensional advection diffusion equation describing the dissolution of a substance into a liquid or gas. A special case (steady state diffusion) leads to Laplace's equation.

### 1.3 Conduction of Heat in a Rod

Consider a rod of constant cross section  $A$  and length  $L$  (see Figure 1) oriented in the  $x$  direction.

Let  $e(x, t)$  denote the thermal energy density or the amount of thermal energy per unit volume. Suppose that the lateral surface of the rod is perfectly insulated. Then there is no thermal energy loss through the lateral surface. The thermal energy may depend on  $x$  and  $t$  if the bar is not uniformly heated. Consider a slice of thickness  $\Delta x$  between  $x$  and  $x + \Delta x$ .

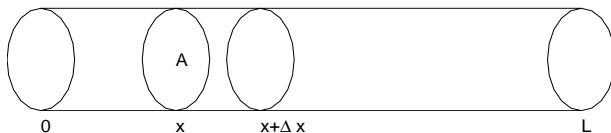

Figure 1: A rod of constant cross section

If the slice is small enough then the total energy in the slice is the product of thermal energy density and the volume, i.e.

$$e(x, t)A\Delta x . \quad (1.3.1)$$

The rate of change of heat energy is given by

$$\frac{\partial}{\partial t}[e(x, t)A\Delta x] . \quad (1.3.2)$$

Using the conservation law of heat energy, we have that this rate of change per unit time is equal to the sum of the heat energy generated inside per unit time and the heat energy flowing across the boundaries per unit time. Let  $\varphi(x, t)$  be the heat flux (amount of thermal energy per unit time flowing to the right per unit surface area). Let  $S(x, t)$  be the heat energy per unit volume generated per unit time. Then the conservation law can be written as follows

$$\frac{\partial}{\partial t}[e(x, t)A\Delta x] = \varphi(x, t)A - \varphi(x + \Delta x, t)A + S(x, t)A\Delta x . \quad (1.3.3)$$

This equation is only an approximation but it is exact at the limit when the thickness of the slice  $\Delta x \rightarrow 0$ . Divide by  $A\Delta x$  and let  $\Delta x \rightarrow 0$ , we have

$$\frac{\partial}{\partial t}e(x, t) = - \underbrace{\lim_{\Delta x \rightarrow 0} \frac{\varphi(x + \Delta x, t) - \varphi(x, t)}{\Delta x}}_{= \frac{\partial \varphi(x, t)}{\partial x}} + S(x, t) . \quad (1.3.4)$$

We now rewrite the equation using the temperature  $u(x, t)$ . The thermal energy density  $e(x, t)$  is given by

$$e(x, t) = c(x)\rho(x)u(x, t) \quad (1.3.5)$$

where  $c(x)$  is the specific heat (heat energy to be supplied to a unit mass to raise its temperature by one degree) and  $\rho(x)$  is the mass density. The heat flux is related to the temperature via Fourier's law

$$\varphi(x, t) = -K \frac{\partial u(x, t)}{\partial x} \quad (1.3.6)$$

where  $K$  is called the thermal conductivity. Substituting (1.3.5) - (1.3.6) in (1.3.4) we obtain

$$c(x)\rho(x) \frac{\partial u}{\partial t} = \frac{\partial}{\partial x} \left( K \frac{\partial u}{\partial x} \right) + S . \quad (1.3.7)$$

For the special case that  $c, \rho, K$  are constants we get

$$u_t = ku_{xx} + Q \quad (1.3.8)$$

where

$$k = \frac{K}{c\rho} \tag{1.3.9}$$

and

$$Q = \frac{S}{c\rho} \tag{1.3.10}$$

## 1.4 Boundary Conditions

In solving the above model, we have to specify two boundary conditions and an initial condition. The initial condition will be the distribution of temperature at time  $t = 0$ , i.e.

$$u(x, 0) = f(x) .$$

The boundary conditions could be of several types.

1. Prescribed temperature (Dirichlet b.c.)

$$u(0, t) = p(t)$$

or

$$u(L, t) = q(t) .$$

2. Insulated boundary (Neumann b.c.)

$$\frac{\partial u(0, t)}{\partial n} = 0$$

where  $\frac{\partial}{\partial n}$  is the derivative in the direction of the outward normal. Thus at  $x = 0$

$$\frac{\partial}{\partial n} = -\frac{\partial}{\partial x}$$

and at  $x = L$

$$\frac{\partial}{\partial n} = \frac{\partial}{\partial x}$$

(see Figure 2).

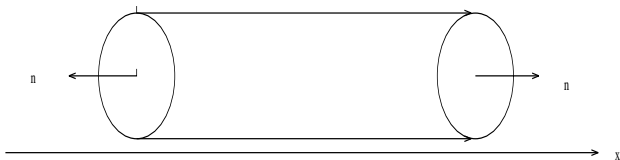

Figure 2: Outward normal vector at the boundary

This condition means that there is no heat flowing out of the rod at that boundary.



### 3. Newton's law of cooling

When a one dimensional wire is in contact at a boundary with a moving fluid or gas, then there is a heat exchange. This is specified by Newton's law of cooling

$$-K(0)\frac{\partial u(0, t)}{\partial x} = -H\{u(0, t) - v(t)\}$$

where  $H$  is the heat transfer (convection) coefficient and  $v(t)$  is the temperature of the surroundings. We may have to solve a problem with a combination of such boundary conditions. For example, one end is insulated and the other end is in a fluid to cool it.

### 4. Periodic boundary conditions

We may be interested in solving the heat equation on a thin circular ring (see figure 3).

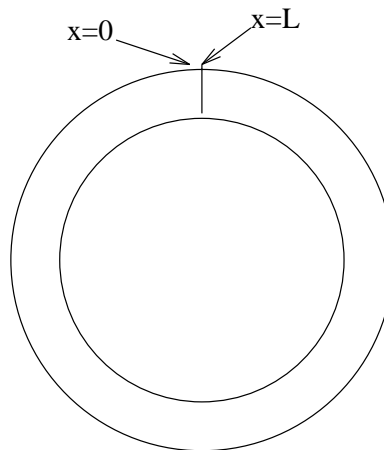

Figure 3: A thin circular ring

If the endpoints of the wire are tightly connected then the temperatures and heat fluxes at both ends are equal, i.e.

$$\begin{aligned}u(0, t) &= u(L, t) \\u_x(0, t) &= u_x(L, t) .\end{aligned}$$

## Problems

1. Suppose the initial temperature of the rod was

$$u(x, 0) = \begin{cases} 2x & 0 \leq x \leq 1/2 \\ 2(1-x) & 1/2 \leq x \leq 1 \end{cases}$$

and the boundary conditions were

$$u(0, t) = u(1, t) = 0,$$

what would be the behavior of the rod's temperature for later time?

2. Suppose the rod has a constant internal heat source, so that the equation describing the heat conduction is

$$u_t = ku_{xx} + Q, \quad 0 < x < 1.$$

Suppose we fix the temperature at the boundaries

$$\begin{aligned} u(0, t) &= 0 \\ u(1, t) &= 1. \end{aligned}$$

What is the steady state temperature of the rod? (Hint: set  $u_t = 0$ .)

3. Derive the heat equation for a rod with thermal conductivity  $K(x)$ .

4. Transform the equation

$$u_t = k(u_{xx} + u_{yy})$$

to polar coordinates and specialize the resulting equation to the case where the function  $u$  does NOT depend on  $\theta$ . (Hint:  $r = \sqrt{x^2 + y^2}$ ,  $\tan \theta = y/x$ )

5. Determine the steady state temperature for a one-dimensional rod with constant thermal properties and

$$\begin{aligned} \text{a. } Q &= 0, & u(0) &= 1, & u(L) &= 0 \\ \text{b. } Q &= 0, & u_x(0) &= 0, & u(L) &= 1 \\ \text{c. } Q &= 0, & u(0) &= 1, & u_x(L) &= \varphi \end{aligned}$$

$$\text{d. } \frac{Q}{k} = x^2, \quad u(0) = 1, \quad u_x(L) = 0$$

$$\text{e. } Q = 0, \quad u(0) = 1, \quad u_x(L) + u(L) = 0$$

## 1.5 A Vibrating String

Suppose we have a tightly stretched string of length  $L$ . We imagine that the ends are tied down in some way (see next section). We describe the motion of the string as a result of disturbing it from equilibrium at time  $t = 0$ , see Figure 4.



Figure 4: A string of length  $L$

We assume that the slope of the string is small and thus the horizontal displacement can be neglected. Consider a small segment of the string between  $x$  and  $x + \Delta x$ . The forces acting on this segment are along the string (tension) and vertical (gravity). Let  $T(x, t)$  be the tension at the point  $x$  at time  $t$ , if we assume the string is flexible then the tension is in the direction tangent to the string, see Figure 5.

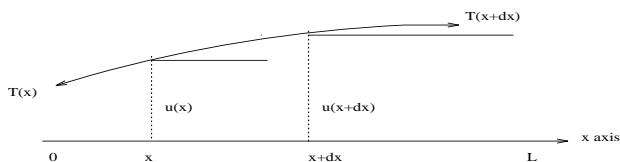

Figure 5: The forces acting on a segment of the string

The slope of the string is given by

$$\tan \theta = \lim_{\Delta x \rightarrow 0} \frac{u(x + \Delta x, t) - u(x, t)}{\Delta x} = \frac{\partial u}{\partial x}. \quad (1.5.1)$$

Thus the sum of all vertical forces is:

$$T(x + \Delta x, t) \sin \theta(x + \Delta x, t) - T(x, t) \sin \theta(x, t) + \rho_0(x) \Delta x Q(x, t) \quad (1.5.2)$$

where  $Q(x, t)$  is the vertical component of the body force per unit mass and  $\rho_0(x)$  is the density. Using Newton's law

$$F = ma = \rho_0(x) \Delta x \frac{\partial^2 u}{\partial t^2}. \quad (1.5.3)$$

Thus

$$\rho_0(x) u_{tt} = \frac{\partial}{\partial x} [T(x, t) \sin \theta(x, t)] + \rho_0(x) Q(x, t) \quad (1.5.4)$$

For small angles  $\theta$ ,

$$\sin \theta \approx \tan \theta \quad (1.5.5)$$

Combining (1.5.1) and (1.5.5) with (1.5.4) we obtain

$$\rho_0(x) u_{tt} = (T(x, t) u_x)_x + \rho_0(x) Q(x, t) \quad (1.5.6)$$

For perfectly elastic strings  $T(x, t) \cong T_0$ . If the only body force is the gravity then

$$Q(x, t) = -g \quad (1.5.7)$$

Thus the equation becomes

$$u_{tt} = c^2 u_{xx} - g \quad (1.5.8)$$

where  $c^2 = T_0/\rho_0(x)$ .

In many situations, the force of gravity is negligible relative to the tensile force and thus we end up with

$$u_{tt} = c^2 u_{xx} . \quad (1.5.9)$$

## 1.6 Boundary Conditions

If an endpoint of the string is fixed, then the displacement is zero and this can be written as

$$u(0, t) = 0 \quad (1.6.1)$$

or

$$u(L, t) = 0 . \quad (1.6.2)$$

We may vary an endpoint in a prescribed way, e.g.

$$u(0, t) = b(t) . \quad (1.6.3)$$

A more interesting condition occurs if the end is attached to a dynamical system (see e.g. Haberman [4])

$$T_0 \frac{\partial u(0, t)}{\partial x} = k (u(0, t) - u_E(t)) . \quad (1.6.4)$$

This is known as an elastic boundary condition. If  $u_E(t) = 0$ , i.e. the equilibrium position of the system coincides with that of the string, then the condition is homogeneous.

As a special case, the free end boundary condition is

$$\frac{\partial u}{\partial x} = 0 . \quad (1.6.5)$$

Since the problem is second order in time, we need two initial conditions. One usually has

$$u(x, 0) = f(x)$$

$$u_t(x, 0) = g(x)$$

i.e. given the displacement and velocity of each segment of the string.

## Problems

1. Derive the telegraph equation

$$u_{tt} + au_t + bu = c^2 u_{xx}$$

by considering the vibration of a string under a damping force proportional to the velocity and a restoring force proportional to the displacement.

2. Use Kirchoff's law to show that the current and potential in a wire satisfy

$$\begin{aligned}i_x + C v_t + Gv &= 0 \\v_x + L i_t + Ri &= 0\end{aligned}$$

where  $i$  = current,  $v = L$  = inductance potential,  $C$  = capacitance,  $G$  = leakage conductance,  $R$  = resistance,

- b. Show how to get the one dimensional wave equations for  $i$  and  $v$  from the above.

## 1.7 Diffusion in Three Dimensions

Diffusion problems lead to partial differential equations that are similar to those of heat conduction. Suppose  $C(x, y, z, t)$  denotes the concentration of a substance, i.e. the mass per unit volume, which is dissolving into a liquid or a gas. For example, pollution in a lake. The amount of a substance (pollutant) in the given domain  $V$  with boundary  $\Gamma$  is given by

$$\int_V C(x, y, z, t) dV . \quad (1.7.1)$$

The law of conservation of mass states that the time rate of change of mass in  $V$  is equal to the rate at which mass flows into  $V$  minus the rate at which mass flows out of  $V$  plus the rate at which mass is produced due to sources in  $V$ . Let's assume that there are no internal sources. Let  $\vec{q}$  be the mass flux vector, then  $\vec{q} \cdot \vec{n}$  gives the mass per unit area per unit time crossing a surface element with outward unit normal vector  $\vec{n}$ .

$$\frac{d}{dt} \int_V C dV = \int_V \frac{\partial C}{\partial t} dV = - \int_{\Gamma} \vec{q} \cdot \vec{n} dS. \quad (1.7.2)$$

Use Gauss divergence theorem to replace the integral on the boundary

$$\int_{\Gamma} \vec{q} \cdot \vec{n} dS = \int_V \text{div } \vec{q} dV. \quad (1.7.3)$$

Therefore

$$\frac{\partial C}{\partial t} = -\text{div } \vec{q}. \quad (1.7.4)$$

Fick's law of diffusion relates the flux vector  $\vec{q}$  to the concentration  $C$  by

$$\vec{q} = -D \text{grad } C + C \vec{v} \quad (1.7.5)$$

where  $\vec{v}$  is the velocity of the liquid or gas, and  $D$  is the diffusion coefficient which may depend on  $C$ . Combining (1.7.4) and (1.7.5) yields

$$\frac{\partial C}{\partial t} = \text{div} (D \text{grad } C) - \text{div}(C \vec{v}). \quad (1.7.6)$$

If  $D$  is constant then

$$\frac{\partial C}{\partial t} = D \nabla^2 C - \nabla \cdot (C \vec{v}) . \quad (1.7.7)$$

If  $\vec{v}$  is negligible or zero then

$$\frac{\partial C}{\partial t} = D \nabla^2 C \quad (1.7.8)$$

which is the same as (1.3.8).

If  $D$  is relatively negligible then one has a first order PDE

$$\frac{\partial C}{\partial t} + \vec{v} \cdot \nabla C + C \text{div } \vec{v} = 0 . \quad (1.7.9)$$

At steady state ( $t$  large enough) the concentration  $C$  will no longer depend on  $t$ . Equation (1.7.6) becomes

$$\nabla \cdot (D \nabla C) - \nabla \cdot (C \vec{v}) = 0 \quad (1.7.10)$$

and if  $\vec{v}$  is negligible or zero then

$$\nabla \cdot (D \nabla C) = 0 \quad (1.7.11)$$

which is Laplace's equation.

## 2 Classification and Characteristics

In this chapter we classify the linear second order PDEs. This will require a discussion of transformations, characteristic curves and canonical forms. We will show that there are three types of PDEs and establish that these three cases are in a certain sense typical of what occurs in the general theory. The type of equation will turn out to be decisive in establishing the kind of initial and boundary conditions that serve in a natural way to determine a solution uniquely (see e.g. Garabedian (1964)).

### 2.1 Physical Classification

Partial differential equations can be classified as equilibrium problems and marching problems. The first class, equilibrium or steady state problems are also known as elliptic. For example, Laplace's or Poisson's equations are of this class. The marching problems include both the parabolic and hyperbolic problems, i.e. those whose solution depends on time.

### 2.2 Classification of Linear Second Order PDEs

Recall that a linear second order PDE in two variables is given by

$$Au_{xx} + Bu_{xy} + Cu_{yy} + Du_x + Eu_y + Fu = G \quad (2.2.1)$$

where all the coefficients  $A$  through  $F$  are real functions of the independent variables  $x, y$ . Define a discriminant  $\Delta(x, y)$  by

$$\Delta(x_0, y_0) = B^2(x_0, y_0) - 4A(x_0, y_0)C(x_0, y_0). \quad (2.2.2)$$

(Notice the similarity to the discriminant defined for conic sections.)

**Definition 7.** An equation is called hyperbolic at the point  $(x_0, y_0)$  if  $\Delta(x_0, y_0) > 0$ . It is parabolic at that point if  $\Delta(x_0, y_0) = 0$  and elliptic if  $\Delta(x_0, y_0) < 0$ .

The classification for equations with more than two independent variables or with higher order derivatives are more complicated. See Courant and Hilbert [5].

Example.

$$\begin{aligned} u_{tt} - c^2 u_{xx} &= 0 \\ A = 1, B = 0, C &= -c^2 \end{aligned}$$

Therefore,

$$\Delta = 0^2 - 4 \cdot 1(-c^2) = 4c^2 \geq 0$$

Thus the problem is hyperbolic for  $c \neq 0$  and parabolic for  $c = 0$ .

The transformation leads to the discovery of special loci known as characteristic curves along which the PDE provides only an incomplete expression for the second derivatives. Before we discuss transformation to canonical forms, we will motivate the name and explain why such transformation is useful. The name canonical form is used because this form



corresponds to particularly simple choices of the coefficients of the second partial derivatives. Such transformation will justify why we only discuss the method of solution of three basic equations (heat equation, wave equation and Laplace's equation). Sometimes, we can obtain the solution of a PDE once it is in a canonical form (several examples will be given later in this chapter). Another reason is that characteristics are useful in solving first order quasilinear and second order linear hyperbolic PDEs, which will be discussed in the next chapter. (In fact nonlinear first order PDEs can be solved that way, see for example F. John (1982).)

To transform the equation into a canonical form, we first show how a general transformation affects equation (2.2.1). Let  $\xi, \eta$  be twice continuously differentiable functions of  $x, y$

$$\xi = \xi(x, y), \quad (2.2.3)$$

$$\eta = \eta(x, y). \quad (2.2.4)$$

Suppose also that the Jacobian  $J$  of the transformation defined by

$$J = \begin{vmatrix} \xi_x & \xi_y \\ \eta_x & \eta_y \end{vmatrix} \quad (2.2.5)$$

is non zero. This assumption is necessary to ensure that one can make the transformation back to the original variables  $x, y$ .

Use the chain rule to obtain all the partial derivatives required in (2.2.1). It is easy to see that

$$u_x = u_\xi \xi_x + u_\eta \eta_x \quad (2.2.6)$$

$$u_y = u_\xi \xi_y + u_\eta \eta_y. \quad (2.2.7)$$

The second partial derivatives can be obtained as follows:

$$\begin{aligned} u_{xy} &= (u_x)_y = (u_\xi \xi_x + u_\eta \eta_x)_y \\ &= (u_\xi \xi_x)_y + (u_\eta \eta_x)_y \\ &= (u_\xi)_y \xi_x + u_\xi \xi_{xy} + (u_\eta)_y \eta_x + u_\eta \eta_{xy} \end{aligned}$$

Now use (2.2.7)

$$u_{xy} = (u_{\xi\xi} \xi_y + u_{\xi\eta} \eta_y) \xi_x + u_\xi \xi_{xy} + (u_{\eta\xi} \xi_y + u_{\eta\eta} \eta_y) \eta_x + u_\eta \eta_{xy}.$$

Reorganize the terms

$$u_{xy} = u_{\xi\xi} \xi_x \xi_y + u_{\xi\eta} (\xi_x \eta_y + \xi_y \eta_x) + u_{\eta\eta} \eta_x \eta_y + u_\xi \xi_{xy} + u_\eta \eta_{xy}. \quad (2.2.8)$$

In a similar fashion we get  $u_{xx}, u_{yy}$

$$u_{xx} = u_{\xi\xi} \xi_x^2 + 2u_{\xi\eta} \xi_x \eta_x + u_{\eta\eta} \eta_x^2 + u_\xi \xi_{xx} + u_\eta \eta_{xx}. \quad (2.2.9)$$

$$u_{yy} = u_{\xi\xi} \xi_y^2 + 2u_{\xi\eta} \xi_y \eta_y + u_{\eta\eta} \eta_y^2 + u_\xi \xi_{yy} + u_\eta \eta_{yy}. \quad (2.2.10)$$

Introducing these into (2.2.1) one finds after collecting like terms

$$A^*u_{\xi\xi} + B^*u_{\xi\eta} + C^*u_{\eta\eta} + D^*u_{\xi} + E^*u_{\eta} + F^*u = G^* \quad (2.2.11)$$

where all the coefficients are now functions of  $\xi, \eta$  and

$$A^* = A\xi_x^2 + B\xi_x\xi_y + C\xi_y^2 \quad (2.2.12)$$

$$B^* = 2A\xi_x\eta_x + B(\xi_x\eta_y + \xi_y\eta_x) + 2C\xi_y\eta_y \quad (2.2.13)$$

$$C^* = A\eta_x^2 + B\eta_x\eta_y + C\eta_y^2 \quad (2.2.14)$$

$$D^* = A\xi_{xx} + B\xi_{xy} + C\xi_{yy} + D\xi_x + E\xi_y \quad (2.2.15)$$

$$E^* = A\eta_{xx} + B\eta_{xy} + C\eta_{yy} + D\eta_x + E\eta_y \quad (2.2.16)$$

$$F^* = F \quad (2.2.17)$$

$$G^* = G. \quad (2.2.18)$$

The resulting equation (2.2.11) is in the same form as the original one. The type of the equation (hyperbolic, parabolic or elliptic) will not change under this transformation. The reason for this is that

$$\Delta^* = (B^*)^2 - 4A^*C^* = J^2(B^2 - 4AC) = J^2\Delta \quad (2.2.19)$$

and since  $J \neq 0$ , the sign of  $\Delta^*$  is the same as that of  $\Delta$ . Proving (2.2.19) is not complicated but definitely messy. It is left for the reader as an exercise using a symbolic manipulator such as MACSYMA or MATHEMATICA.

The classification depends only on the coefficients of the second derivative terms and thus we write (2.2.1) and (2.2.11) respectively as

$$Au_{xx} + Bu_{xy} + Cu_{yy} = H(x, y, u, u_x, u_y) \quad (2.2.20)$$

and

$$A^*u_{\xi\xi} + B^*u_{\xi\eta} + C^*u_{\eta\eta} = H^*(\xi, \eta, u, u_{\xi}, u_{\eta}). \quad (2.2.21)$$

## Problems

1. Classify each of the following as hyperbolic, parabolic or elliptic at every point  $(x, y)$  of the domain

- a.  $x u_{xx} + u_{yy} = x^2$
- b.  $x^2 u_{xx} - 2xy u_{xy} + y^2 u_{yy} = e^x$
- c.  $e^x u_{xx} + e^y u_{yy} = u$
- d.  $u_{xx} + u_{xy} - x u_{yy} = 0$  in the left half plane ( $x \leq 0$ )
- e.  $x^2 u_{xx} + 2xy u_{xy} + y^2 u_{yy} + xy u_x + y^2 u_y = 0$
- f.  $u_{xx} + x u_{yy} = 0$  (Tricomi equation)

2. Classify each of the following constant coefficient equations

- a.  $4u_{xx} + 5u_{xy} + u_{yy} + u_x + u_y = 2$
- b.  $u_{xx} + u_{xy} + u_{yy} + u_x = 0$
- c.  $3u_{xx} + 10u_{xy} + 3u_{yy} = 0$
- d.  $u_{xx} + 2u_{xy} + 3u_{yy} + 4u_x + 5u_y + u = e^x$
- e.  $2u_{xx} - 4u_{xy} + 2u_{yy} + 3u = 0$
- f.  $u_{xx} + 5u_{xy} + 4u_{yy} + 7u_y = \sin x$

3. Use any symbolic manipulator (e.g. MACSYMA or MATHEMATICA) to prove (2.2.19). This means that a transformation does NOT change the type of the PDE.

## 2.3 Canonical Forms

In this section we discuss canonical forms, which correspond to particularly simple choices of the coefficients of the second partial derivatives of the unknown. To obtain a canonical form, we have to transform the PDE which in turn will require the knowledge of characteristic curves. Three equivalent properties of characteristic curves, each can be used as a definition:

1. Initial data on a characteristic curve cannot be prescribed freely, but must satisfy a compatibility condition.
2. Discontinuities (of a certain nature) of a solution cannot occur except along characteristics.
3. Characteristics are the only possible “branch lines” of solutions, i.e. lines for which the same initial value problems may have several solutions.

We now consider specific choices for the functions  $\xi, \eta$ . This will be done in such a way that some of the coefficients  $A^*, B^*,$  and  $C^*$  in (2.2.21) become zero.

### 2.3.1 Hyperbolic

Note that  $A^*, C^*$  are similar and can be written as

$$A\zeta_x^2 + B\zeta_x\zeta_y + C\zeta_y^2 \quad (2.3.1.1)$$

in which  $\zeta$  stands for either  $\xi$  or  $\eta$ . Suppose we try to choose  $\xi, \eta$  such that  $A^* = C^* = 0$ . This is of course possible only if the equation is hyperbolic. (Recall that  $\Delta^* = (B^*)^2 - 4A^*C^*$  and for this choice  $\Delta^* = (B^*)^2 > 0$ . Since the type does not change under the transformation, we must have a hyperbolic PDE.) In order to annihilate  $A^*$  and  $C^*$  we have to find  $\zeta$  such that

$$A\zeta_x^2 + B\zeta_x\zeta_y + C\zeta_y^2 = 0. \quad (2.3.1.2)$$

Dividing by  $\zeta_y^2$ , the above equation becomes

$$A \left( \frac{\zeta_x}{\zeta_y} \right)^2 + B \left( \frac{\zeta_x}{\zeta_y} \right) + C = 0. \quad (2.3.1.3)$$

Along the curve

$$\zeta(x, y) = \text{constant}, \quad (2.3.1.4)$$

we have

$$d\zeta = \zeta_x dx + \zeta_y dy = 0. \quad (2.3.1.5)$$

Therefore,

$$\frac{\zeta_x}{\zeta_y} = -\frac{dy}{dx} \quad (2.3.1.6)$$

and equation (2.3.1.3) becomes

$$A \left( \frac{dy}{dx} \right)^2 - B \frac{dy}{dx} + C = 0. \quad (2.3.1.7)$$

This is a quadratic equation for  $\frac{dy}{dx}$  and its roots are

$$\frac{dy}{dx} = \frac{B \pm \sqrt{B^2 - 4AC}}{2A}. \quad (2.3.1.8)$$

These equations are called characteristic equations and are ordinary differential equations for families of curves in  $x, y$  plane along which  $\zeta = \text{constant}$ . The solutions are called characteristic curves. Notice that the discriminant is under the radical in (2.3.1.8) and since the problem is hyperbolic,  $B^2 - 4AC > 0$ , there are two distinct characteristic curves. We can choose one to be  $\xi(x, y)$  and the other  $\eta(x, y)$ . Solving the ODEs (2.3.1.8), we get

$$\phi_1(x, y) = C_1, \quad (2.3.1.9)$$

$$\phi_2(x, y) = C_2. \quad (2.3.1.10)$$

Thus the transformation

$$\xi = \phi_1(x, y) \quad (2.3.1.11)$$

$$\eta = \phi_2(x, y) \quad (2.3.1.12)$$

will lead to  $A^* = C^* = 0$  and the canonical form is

$$B^* u_{\xi\eta} = H^* \quad (2.3.1.13)$$

or after division by  $B^*$

$$u_{\xi\eta} = \frac{H^*}{B^*}. \quad (2.3.1.14)$$

This is called the first canonical form of the hyperbolic equation.

Sometimes we find another canonical form for hyperbolic PDEs which is obtained by making a transformation

$$\alpha = \xi + \eta \quad (2.3.1.15)$$

$$\beta = \xi - \eta. \quad (2.3.1.16)$$

Using (2.3.1.6)-(2.3.1.8) for this transformation one has

$$u_{\alpha\alpha} - u_{\beta\beta} = H^{**}(\alpha, \beta, u, u_\alpha, u_\beta). \quad (2.3.1.17)$$

This is called the second canonical form of the hyperbolic equation.

### Example

$$y^2 u_{xx} - x^2 u_{yy} = 0 \quad \text{for } x > 0, y > 0 \quad (2.3.1.18)$$

$$A = y^2$$

$$B = 0$$

$$C = -x^2$$

$$\Delta = 0 - 4y^2(-x^2) = 4x^2y^2 > 0$$

The equation is hyperbolic for all  $x, y$  of interest.

The characteristic equation

$$\frac{dy}{dx} = \frac{0 \pm \sqrt{4x^2y^2}}{2y^2} = \frac{\pm 2xy}{2y^2} = \pm \frac{x}{y}. \quad (2.3.1.19)$$

These equations are separable ODEs and the solutions are

$$\frac{1}{2}y^2 - \frac{1}{2}x^2 = c_1$$

$$\frac{1}{2}y^2 + \frac{1}{2}x^2 = c_2$$

The first is a family of hyperbolas and the second is a family of circles (see figure 6).

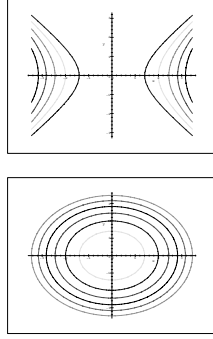

Figure 6: The families of characteristics for the hyperbolic example

We take then the following transformation

$$\xi = \frac{1}{2}y^2 - \frac{1}{2}x^2 \quad (2.3.1.20)$$

$$\eta = \frac{1}{2}y^2 + \frac{1}{2}x^2 \quad (2.3.1.21)$$

Evaluate all derivatives of  $\xi, \eta$  necessary for (2.2.6) - (2.2.10)

$$\xi_x = -x, \quad \xi_y = y, \quad \xi_{xx} = -1, \quad \xi_{xy} = 0, \quad \xi_{yy} = 1$$

$$\eta_x = x, \quad \eta_y = y, \quad \eta_{xx} = 1, \quad \eta_{xy} = 0, \quad \eta_{yy} = 1.$$

Substituting all these in the expressions for  $B^*, D^*, E^*$  (you can check that  $A^* = C^* = 0$ )

$$B^* = 2y^2(-x)x + 2(-x^2)y \cdot y = -2x^2y^2 - 2x^2y^2 = -4x^2y^2.$$

$$D^* = y^2(-1) + (-x^2) \cdot 1 = -x^2 - y^2.$$

$$E^* = y^2 \cdot 1 + (-x^2) \cdot 1 = y^2 - x^2.$$

Now solve (2.3.1.20) - (2.3.1.21) for  $x, y$

$$x^2 = \eta - \xi,$$

$$y^2 = \xi + \eta,$$

and substitute in  $B^*, D^*, E^*$  we get

$$-4(\eta - \xi)(\xi + \eta)u_{\xi\eta} + (-\eta + \xi - \xi - \eta)u_\xi + (\xi + \eta - \eta + \xi)u_\eta = 0$$

$$4(\xi^2 - \eta^2)u_{\xi\eta} - 2\eta u_\xi + 2\xi u_\eta = 0$$

$$u_{\xi\eta} = \frac{\eta}{2(\xi^2 - \eta^2)}u_\xi - \frac{\xi}{2(\xi^2 - \eta^2)}u_\eta \quad (2.3.1.22)$$

This is the first canonical form of (2.3.1.18).

### 2.3.2 Parabolic

Since  $\Delta^* = 0$ ,  $B^2 - 4AC = 0$  and thus

$$B = \pm 2\sqrt{A}\sqrt{C}. \quad (2.3.2.1)$$

Clearly we cannot arrange for both  $A^*$  and  $C^*$  to be zero, since the characteristic equation (2.3.1.8) can have only one solution. That means that parabolic equations have only one characteristic curve. Suppose we choose the solution  $\phi_1(x, y)$  of (2.3.1.8)

$$\frac{dy}{dx} = \frac{B}{2A} \quad (2.3.2.2)$$

to define

$$\xi = \phi_1(x, y). \quad (2.3.2.3)$$

Therefore  $A^* = 0$ .

Using (2.3.2.1) we can show that

$$\begin{aligned} 0 = A^* &= A\xi_x^2 + B\xi_x\xi_y + C\xi_y^2 \\ &= A\xi_x^2 + 2\sqrt{A}\sqrt{C}\xi_x\xi_y + C\xi_y^2 \\ &= (\sqrt{A}\xi_x + \sqrt{C}\xi_y)^2 \end{aligned} \quad (2.3.2.4)$$

It is also easy to see that

$$\begin{aligned} B^* &= 2A\xi_x\eta_x + B(\xi_x\eta_y + \xi_y\eta_x) + 2C\xi_y\eta_y \\ &= 2(\sqrt{A}\xi_x + \sqrt{C}\xi_y)(\sqrt{A}\eta_x + \sqrt{C}\eta_y) \\ &= 0 \end{aligned}$$

The last step is a result of (2.3.2.4). Therefore  $A^* = B^* = 0$ . To obtain the canonical form we must choose a function  $\eta(x, y)$ . This can be taken judiciously as long as we ensure that the Jacobian is not zero.

The canonical form is then

$$C^* u_{\eta\eta} = H^*$$

and after dividing by  $C^*$  (which cannot be zero) we have

$$u_{\eta\eta} = \frac{H^*}{C^*}. \quad (2.3.2.5)$$

If we choose  $\eta = \phi_1(x, y)$  instead of (2.3.2.3), we will have  $C^* = 0$ . In this case  $B^* = 0$  because the last factor  $\sqrt{A}\eta_x + \sqrt{C}\eta_y$  is zero. The canonical form in this case is

$$u_{\xi\xi} = \frac{H^*}{A^*} \quad (2.3.2.6)$$

Example

$$x^2 u_{xx} - 2xy u_{xy} + y^2 u_{yy} = e^x \quad (2.3.2.7)$$

$$A = x^2$$

$$B = -2xy$$

$$C = y^2$$

$$\Delta = (-2xy)^2 - 4 \cdot x^2 \cdot y^2 = 4x^2y^2 - 4x^2y^2 = 0.$$

Thus the equation is parabolic for all  $x, y$ . The characteristic equation (2.3.2.2) is

$$\frac{dy}{dx} = \frac{-2xy}{2x^2} = -\frac{y}{x}. \quad (2.3.2.8)$$

Solve

$$\frac{dy}{y} = -\frac{dx}{x}$$

$$\ln y + \ln x = C$$

In figure 7 we sketch the family of characteristics for (2.3.2.7). Note that since the problem is parabolic, there is **ONLY** one family.

Therefore we can take  $\xi$  to be this family

$$\xi = \ln y + \ln x \quad (2.3.2.9)$$

and  $\eta$  is arbitrary as long as  $J \neq 0$ . We take

$$\eta = x. \quad (2.3.2.10)$$



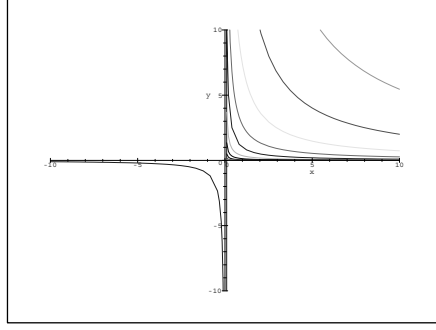

Figure 7: The family of characteristics for the parabolic example

Computing the necessary derivatives of  $\xi, \eta$  we have

$$\xi_x = \frac{1}{x}, \quad \xi_y = \frac{1}{y}, \quad \xi_{xx} = -\frac{1}{x^2}, \quad \xi_{xy} = 0, \quad \xi_{yy} = -\frac{1}{y^2}$$

$$\eta_x = 1, \quad \eta_y = \eta_{xx} = \eta_{xy} = \eta_{yy} = 0.$$

Substituting these derivatives in the expressions for  $C^*, D^*, E^*$  (recall that  $A^* = B^* = 0$ )

$$C^* = x^2 \cdot 1$$

$$D^* = x^2 \cdot \left(-\frac{1}{x^2}\right) - 2xy \cdot 0 + y^2 \cdot \left(-\frac{1}{y^2}\right) = -1 - 1 = -2$$

$$E^* = 0.$$

The equation in the canonical form ( $H^* = -D^*u_\xi + G^*$  in this case)

$$u_{\eta\eta} = \frac{2u_\xi + e^x}{x^2}$$

Now we must eliminate the old variables. Since  $x = \eta$  we have

$$u_{\eta\eta} = \frac{2}{\eta^2}u_\xi + \frac{1}{\eta^2}e^\eta. \quad (2.3.2.11)$$

Note that a different choice for  $\eta$  will lead to a different right hand side in (2.3.2.11).

### 2.3.3 Elliptic

This is the case that  $\Delta < 0$  and therefore there are NO real solutions to the characteristic equation (2.3.1.8). Suppose we solve for the complex valued functions  $\xi$  and  $\eta$ . We now define

$$\alpha = \frac{\xi + \eta}{2} \quad (2.3.3.1)$$

$$\beta = \frac{\xi - \eta}{2i} \quad (2.3.3.2)$$

that is  $\alpha$  and  $\beta$  are the real and imaginary parts of  $\xi$ . Clearly  $\eta$  is the complex conjugate of  $\xi$  since the coefficients of the characteristic equation are real. If we use these functions  $\alpha(x, y)$  and  $\beta(x, y)$  we get an equation for which

$$B^{**} = 0, \quad A^{**} = C^{**}. \quad (2.3.3.3)$$

To show that (2.3.3.3) is correct, recall that our choice of  $\xi, \eta$  led to  $A^* = C^* = 0$ . These are

$$A^* = (A\alpha_x^2 + B\alpha_x\alpha_y + C\alpha_y^2) - (A\beta_x^2 + B\beta_x\beta_y + C\beta_y^2) + i[2A\alpha_x\beta_x + B(\alpha_x\beta_y + \alpha_y\beta_x) + 2C\alpha_y\beta_y] = 0$$

$$C^* = (A\alpha_x^2 + B\alpha_x\alpha_y + C\alpha_y^2) - (A\beta_x^2 + B\beta_x\beta_y + C\beta_y^2) - i[2A\alpha_x\beta_x + B(\alpha_x\beta_y + \alpha_y\beta_x) + 2C\alpha_y\beta_y] = 0$$

Note the similarity of the terms in each bracket to those in (2.3.1.12)-(2.3.1.14)

$$A^* = (A^{**} - C^{**}) + iB^{**} = 0$$

$$C^* = (A^{**} - C^{**}) - iB^{**} = 0$$

where the double starred coefficients are given as in (2.3.1.12)-(2.3.1.14) except that  $\alpha, \beta$  replace  $\xi, \eta$  correspondingly. These last equations can be satisfied if and only if (2.3.3.3) is satisfied.

Therefore

$$A^{**}u_{\alpha\alpha} + A^{**}u_{\beta\beta} = H^{**}(\alpha, \beta, u, u_\alpha, u_\beta)$$

and the canonical form is

$$u_{\alpha\alpha} + u_{\beta\beta} = \frac{H^{**}}{A^{**}}. \quad (2.3.3.4)$$

Example

$$e^x u_{xx} + e^y u_{yy} = u \quad (2.3.3.5)$$

$$A = e^x$$

$$B = 0$$

$$C = e^y$$

$$\Delta = 0^2 - 4e^x e^y < 0, \quad \text{for all } x, y$$

The characteristic equation

$$\frac{dy}{dx} = \frac{0 \pm \sqrt{-4e^x e^y}}{2e^x} = \frac{\pm 2i\sqrt{e^x e^y}}{2e^x} = \pm i\sqrt{\frac{e^y}{e^x}}$$

$$\frac{dy}{e^{y/2}} = \pm i \frac{dx}{e^{x/2}}.$$

Therefore

$$\xi = -2e^{-y/2} - 2ie^{-x/2}$$

$$\eta = -2e^{-y/2} + 2ie^{-x/2}$$

The real and imaginary parts are:

$$\alpha = -2e^{-y/2} \quad (2.3.3.6)$$

$$\beta = -2e^{-x/2}. \quad (2.3.3.7)$$

Evaluate all necessary partial derivatives of  $\alpha, \beta$

$$\alpha_x = 0, \quad \alpha_y = e^{-y/2}, \quad \alpha_{xx} = 0, \quad \alpha_{xy} = 0, \quad \alpha_{yy} = -\frac{1}{2}e^{-y/2}$$

$$\beta_x = e^{-x/2}, \quad \beta_y = 0, \quad \beta_{xx} = -\frac{1}{2}e^{-x/2}, \quad \beta_{xy} = 0, \quad \beta_{yy} = 0$$

Now, instead of using both transformations, we recall that (2.3.1.12)-(2.3.1.18) are valid with  $\alpha, \beta$  instead of  $\xi, \eta$ . Thus

$$A^* = e^x \cdot 0 + 0 + e^y (e^{-y/2})^2 = 1$$

$$B^* = 0 + 0 + 0 = 0 \quad \text{as can be expected}$$

$$C^* = e^x (e^{-x/2})^2 + 0 + 0 = 1 \quad \text{as can be expected}$$

$$D^* = 0 + 0 + e^y \left(-\frac{1}{2}e^{-y/2}\right) = -\frac{1}{2}e^{y/2}$$

$$E^* = e^x \left(-\frac{1}{2}e^{-x/2}\right) + 0 + 0 = -\frac{1}{2}e^{x/2}$$

$$F^* = -1$$

$$H^* = -D^*u_\alpha - E^*u_\beta - F^*u = \frac{1}{2}e^{y/2}u_\alpha + \frac{1}{2}e^{x/2}u_\beta + u.$$

Thus

$$u_{\alpha\alpha} + u_{\beta\beta} = \frac{1}{2}e^{y/2}u_\alpha + \frac{1}{2}e^{x/2}u_\beta + u.$$

Using (2.3.3.6)-(2.3.3.7) we have

$$e^{x/2} = -\frac{2}{\beta}$$

$$e^{y/2} = -\frac{2}{\alpha}$$

and therefore the canonical form is

$$u_{\alpha\alpha} + u_{\beta\beta} = -\frac{1}{\alpha}u_\alpha - \frac{1}{\beta}u_\beta + u. \quad (2.3.3.8)$$

## Problems

1. Find the characteristic equation, characteristic curves and obtain a canonical form for each

- a.  $x u_{xx} + u_{yy} = x^2$
- b.  $u_{xx} + u_{xy} - x u_{yy} = 0 \quad (x \leq 0, \text{ all } y)$
- c.  $x^2 u_{xx} + 2xy u_{xy} + y^2 u_{yy} + xy u_x + y^2 u_y = 0$
- d.  $u_{xx} + x u_{yy} = 0$
- e.  $u_{xx} + y^2 u_{yy} = y$
- f.  $\sin^2 x u_{xx} + \sin 2x u_{xy} + \cos^2 x u_{yy} = x$

2. Use Maple to plot the families of characteristic curves for each of the above.

## 2.4 Equations with Constant Coefficients

In this case the discriminant is constant and thus the type of the equation is the same everywhere in the domain. The characteristic equation is easy to integrate.

### 2.4.1 Hyperbolic

The characteristic equation is

$$\frac{dy}{dx} = \frac{B \pm \sqrt{\Delta}}{2A}. \quad (2.4.1.1)$$

Thus

$$dy = \frac{B \pm \sqrt{\Delta}}{2A} dx$$

and integration yields two families of straight lines

$$\xi = y - \frac{B + \sqrt{\Delta}}{2A} x \quad (2.4.1.2)$$

$$\eta = y - \frac{B - \sqrt{\Delta}}{2A} x. \quad (2.4.1.3)$$

Notice that if  $A = 0$  then (2.4.1.1) is not valid. In this case we recall that (2.4.1.2) is

$$B\zeta_x\zeta_y + C\zeta_y^2 = 0 \quad (2.4.1.4)$$

If we divide by  $\zeta_y^2$  as before we get

$$B\frac{\zeta_x}{\zeta_y} + C = 0 \quad (2.4.1.5)$$

which is only linear and thus we get only one characteristic family. To overcome this difficulty we divide (2.4.1.4) by  $\zeta_x^2$  to get

$$B\frac{\zeta_y}{\zeta_x} + C\left(\frac{\zeta_y}{\zeta_x}\right)^2 = 0 \quad (2.4.1.6)$$

which is quadratic. Now

$$\frac{\zeta_y}{\zeta_x} = -\frac{dx}{dy}$$

and so

$$\frac{dx}{dy} = \frac{B \pm \sqrt{B^2 - 4 \cdot 0 \cdot C}}{2C} = \frac{B \pm B}{2C}$$

or

$$\frac{dx}{dy} = 0, \quad \frac{dx}{dy} = \frac{B}{C}. \quad (2.4.1.7)$$

The transformation is then

$$\xi = x, \quad (2.4.1.8)$$

$$\eta = x - \frac{B}{C}y. \quad (2.4.1.9)$$

The canonical form is similar to (2.3.1.14).

## 2.4.2 Parabolic

The only solution of (2.4.1.1) is

$$\frac{dy}{dx} = \frac{B}{2A}.$$

Thus

$$\xi = y - \frac{B}{2A}x. \quad (2.4.2.1)$$

Again  $\eta$  is chosen judiciously but in such a way that the Jacobian of the transformation is not zero.

Can  $A$  be zero in this case? In the parabolic case  $A = 0$  implies  $B = 0$  (since  $\Delta = B^2 - 4 \cdot 0 \cdot C$  must be zero.) Therefore the original equation is

$$Cu_{yy} + Du_x + Eu_y + Fu = G$$

which is already in canonical form

$$u_{yy} = -\frac{D}{C}u_x - \frac{E}{C}u_y - \frac{F}{C}u + \frac{G}{C}. \quad (2.4.2.2)$$

## 2.4.3 Elliptic

Now we have complex conjugate functions  $\xi, \eta$

$$\xi = y - \frac{B + i\sqrt{-\Delta}}{2A}x, \quad (2.4.3.1)$$

$$\eta = y - \frac{B - i\sqrt{-\Delta}}{2A}x. \quad (2.4.3.2)$$

Therefore

$$\alpha = y - \frac{B}{2A}x, \quad (2.4.3.3)$$

$$\beta = \frac{-\sqrt{-\Delta}}{2A}x. \quad (2.4.3.4)$$

(Note that  $-\Delta > 0$  and the radical yields a real number.) The canonical form is similar to (2.3.3.4).

Example

$$u_{tt} - c^2u_{xx} = 0 \quad (\text{wave equation}) \quad (2.4.3.5)$$

$$A = 1$$

$$B = 0$$

$$C = -c^2$$

$$\Delta = 4c^2 > 0 \quad (\text{hyperbolic}).$$

The characteristic equation is

$$\left(\frac{dx}{dt}\right)^2 - c^2 = 0$$

and the transformation is

$$\xi = x + ct, \tag{2.4.3.6}$$

$$\eta = x - ct. \tag{2.4.3.7}$$

The canonical form can be obtained as in the previous examples

$$u_{\xi\eta} = 0. \tag{2.4.3.8}$$

This is exactly the example from Chapter 1 for which we had

$$u(\xi, \eta) = F(\xi) + G(\eta). \tag{2.4.3.9}$$

The solution in terms of  $x, t$  is then (use (2.4.3.6)-(2.4.3.7))

$$u(x, t) = F(x + ct) + G(x - ct). \tag{2.4.3.10}$$

## Problems

1. Find the characteristic equation, characteristic curves and obtain a canonical form for

a.  $4u_{xx} + 5u_{xy} + u_{yy} + u_x + u_y = 2$

b.  $u_{xx} + u_{xy} + u_{yy} + u_x = 0$

c.  $3u_{xx} + 10u_{xy} + 3u_{yy} = x + 1$

d.  $u_{xx} + 2u_{xy} + 3u_{yy} + 4u_x + 5u_y + u = e^x$

e.  $2u_{xx} - 4u_{xy} + 2u_{yy} + 3u = 0$

f.  $u_{xx} + 5u_{xy} + 4u_{yy} + 7u_y = \sin x$

2. Use Maple to plot the families of characteristic curves for each of the above.



## 2.5 Linear Systems

In general, linear systems can be written in the form:

$$\frac{\partial \mathbf{u}}{\partial t} + A \frac{\partial \mathbf{u}}{\partial x} + B \frac{\partial \mathbf{u}}{\partial y} + \mathbf{r} = 0 \quad (2.5.1)$$

where  $\mathbf{u}$  is a vector valued function of  $t, x, y$ .

The system is called hyperbolic at a point  $(t, x)$  if the eigenvalues of  $A$  are all real and distinct. Similarly at a point  $(t, y)$  if the eigenvalues of  $B$  are real and distinct.

Example The system of equations

$$v_t = cv_x \quad (2.5.2)$$

$$w_t = cw_x \quad (2.5.3)$$

can be written in matrix form as

$$\frac{\partial \mathbf{u}}{\partial t} + A \frac{\partial \mathbf{u}}{\partial x} = 0 \quad (2.5.4)$$

where

$$\mathbf{u} = \begin{pmatrix} v \\ w \end{pmatrix} \quad (2.5.5)$$

and

$$A = \begin{pmatrix} 0 & -c \\ -c & 0 \end{pmatrix}. \quad (2.5.6)$$

The eigenvalues of  $A$  are given by

$$\lambda^2 - c^2 = 0 \quad (2.5.7)$$

or  $\lambda = c, -c$ . Therefore the system is hyperbolic, which we knew in advance since the system is the familiar wave equation.

Example The system of equations

$$u_x = v_y \quad (2.5.8)$$

$$u_y = -v_x \quad (2.5.9)$$

can be written in matrix form

$$\frac{\partial \mathbf{w}}{\partial x} + A \frac{\partial \mathbf{w}}{\partial y} = 0 \quad (2.5.10)$$

where

$$\mathbf{w} = \begin{pmatrix} u \\ v \end{pmatrix} \quad (2.5.11)$$

and

$$A = \begin{pmatrix} 0 & -1 \\ 1 & 0 \end{pmatrix}. \quad (2.5.12)$$

The eigenvalues of  $A$  are given by

$$\lambda^2 + 1 = 0 \quad (2.5.13)$$

or  $\lambda = i, -i$ . Therefore the system is elliptic. In fact, this system is the same as Laplace's equation.

## 2.6 General Solution

As we mentioned earlier, sometimes we can get the general solution of an equation by transforming it to a canonical form. We have seen one example (namely the wave equation) in the last section.

### Example

$$x^2 u_{xx} + 2xy u_{xy} + y^2 u_{yy} = 0. \quad (2.6.1)$$

Show that the canonical form is

$$u_{\eta\eta} = 0 \quad \text{for } y \neq 0 \quad (2.6.2)$$

$$u_{xx} = 0 \quad \text{for } y = 0. \quad (2.6.3)$$

To solve (2.6.2) we integrate with respect to  $\eta$  twice ( $\xi$  is fixed) to get

$$u(\xi, \eta) = \eta F(\xi) + G(\xi). \quad (2.6.4)$$

Since the transformation to canonical form is

$$\xi = \frac{y}{x} \quad \eta = y \quad (\text{arbitrary choice for } \eta) \quad (2.6.5)$$

then

$$u(x, y) = yF\left(\frac{y}{x}\right) + G\left(\frac{y}{x}\right). \quad (2.6.6)$$

### Example

Obtain the general solution for

$$4u_{xx} + 5u_{xy} + u_{yy} + u_x + u_y = 2. \quad (2.6.7)$$

(This example is taken from Myint-U and Debnath (19).) There is a mistake in their solution which we have corrected here. The transformation

$$\begin{aligned} \xi &= y - x, \\ \eta &= y - \frac{x}{4}, \end{aligned} \quad (2.6.8)$$

leads to the canonical form

$$u_{\xi\eta} = \frac{1}{3}u_{\eta} - \frac{8}{9}. \quad (2.6.9)$$

Let  $v = u_{\eta}$  then (2.6.9) can be written as

$$v_{\xi} = \frac{1}{3}v - \frac{8}{9} \quad (2.6.10)$$

which is a first order linear ODE (assuming  $\eta$  is fixed.) Therefore

$$v = \frac{8}{3} + e^{\xi/3}\phi(\eta). \quad (2.6.11)$$

Now integrating with respect to  $\eta$  yields

$$u(\xi, \eta) = \frac{8}{3}\eta + G(\eta)e^{\xi/3} + F(\xi). \quad (2.6.12)$$

In terms of  $x, y$  the solution is

$$u(x, y) = \frac{8}{3}\left(y - \frac{x}{4}\right) + G\left(y - \frac{x}{4}\right)e^{(y-x)/3} + F(y - x). \quad (2.6.13)$$

## Problems

1. Determine the general solution of

a.  $u_{xx} - \frac{1}{c^2}u_{yy} = 0 \quad c = \text{constant}$

b.  $u_{xx} - 3u_{xy} + 2u_{yy} = 0$

c.  $u_{xx} + u_{xy} = 0$

d.  $u_{xx} + 10u_{xy} + 9u_{yy} = y$

2. Transform the following equations to

$$U_{\xi\eta} = cU$$

by introducing the new variables

$$U = ue^{-(\alpha\xi + \beta\eta)}$$

where  $\alpha, \beta$  to be determined

a.  $u_{xx} - u_{yy} + 3u_x - 2u_y + u = 0$

b.  $3u_{xx} + 7u_{xy} + 2u_{yy} + u_y + u = 0$

(Hint: First obtain a canonical form. If you take the right transformation to canonical form then you can transform the equation in (a) to

$$U_{\xi\eta} = cU_{\eta}$$

and this can be integrated to get the exact solution. Is it possible to do that for part b?)

3. Show that

$$u_{xx} = au_t + bu_x - \frac{b^2}{4}u + d$$

is parabolic for  $a, b, d$  constants. Show that the substitution

$$u(x, t) = v(x, t)e^{\frac{b}{2}x}$$

transforms the equation to

$$v_{xx} = av_t + de^{-\frac{b}{2}x}$$

## Summary

Equation

$$Au_{xx} + Bu_{xy} + Cu_{yy} = -Du_x - Eu_y - Fu + G = H(x, y, u, u_x, u_y)$$

Discriminant

$$\Delta(x_0, y_0) = B^2(x_0, y_0) - 4A(x_0, y_0)C(x_0, y_0)$$

Class

$$\Delta > 0 \quad \text{hyperbolic at the point } (x_0, y_0)$$

$$\Delta = 0 \quad \text{parabolic at the point } (x_0, y_0)$$

$$\Delta < 0 \quad \text{elliptic at the point } (x_0, y_0)$$

Transformed Equation

$$A^*u_{\xi\xi} + B^*u_{\xi\eta} + C^*u_{\eta\eta} = -D^*u_{\xi} - E^*u_{\eta} - F^*u + G^* = H^*(\xi, \eta, u, u_{\xi}, u_{\eta})$$

where

$$A^* = A\xi_x^2 + B\xi_x\xi_y + C\xi_y^2$$

$$B^* = 2A\xi_x\eta_x + B(\xi_x\eta_y + \xi_y\eta_x) + 2C\xi_y\eta_y$$

$$C^* = A\eta_x^2 + B\eta_x\eta_y + C\eta_y^2$$

$$D^* = A\xi_{xx} + B\xi_{xy} + C\xi_{yy} + D\xi_x + E\xi_y$$

$$E^* = A\eta_{xx} + B\eta_{xy} + C\eta_{yy} + D\eta_x + E\eta_y$$

$$F^* = F$$

$$G^* = G$$

$$H^* = -D^*u_{\xi} - E^*u_{\eta} - F^*u + G^*$$

$$\frac{dy}{dx} = \frac{B \pm \sqrt{\Delta}}{2A} \quad \text{characteristic equation}$$

$$u_{\xi\eta} = \frac{H^*}{B^*} \quad \text{first canonical form for hyperbolic}$$

$$u_{\alpha\alpha} - u_{\beta\beta} = \frac{H^{**}}{B^{**}} \quad \alpha = \xi + \eta, \beta = \xi - \eta \quad \text{second canonical form for hyperbolic}$$

$$u_{\xi\xi} = \frac{H^*}{A^*} \quad \text{a canonical form for parabolic}$$

$$u_{\eta\eta} = \frac{H^*}{C^*} \quad \text{a canonical form for parabolic}$$

$$u_{\alpha\alpha} + u_{\beta\beta} = \frac{H^{**}}{A^{**}} \quad \alpha = (\xi + \eta)/2, \beta = (\xi - \eta)/2i \quad \text{a canonical form for elliptic}$$

### 3 Method of Characteristics

In this chapter we will discuss a method to solve first order linear and quasilinear PDEs. This method is based on finding the characteristic curve of the PDE. We will also show how to generalize this method for a second order constant coefficients wave equation. The method of characteristics can be used only for hyperbolic problems which possess the right number of characteristic families. Recall that for second order parabolic problems we have only one family of characteristics and for elliptic PDEs no real characteristic curves exist.

#### 3.1 Advection Equation (first order wave equation)

The one dimensional wave equation

$$\frac{\partial^2 u}{\partial t^2} - c^2 \frac{\partial^2 u}{\partial x^2} = 0 \tag{3.1.1}$$

can be rewritten as either of the following

$$\left( \frac{\partial}{\partial t} + c \frac{\partial}{\partial x} \right) \left( \frac{\partial}{\partial t} - c \frac{\partial}{\partial x} \right) u = 0 \tag{3.1.2}$$

$$\left( \frac{\partial}{\partial t} - c \frac{\partial}{\partial x} \right) \left( \frac{\partial}{\partial t} + c \frac{\partial}{\partial x} \right) u = 0 \tag{3.1.3}$$

since the mixed derivative terms cancel. If we let

$$v = \frac{\partial u}{\partial t} - c \frac{\partial u}{\partial x} \tag{3.1.4}$$

then (3.1.2) becomes

$$\frac{\partial v}{\partial t} + c \frac{\partial v}{\partial x} = 0. \tag{3.1.5}$$

Similarly (3.1.3) yields

$$\frac{\partial w}{\partial t} - c \frac{\partial w}{\partial x} = 0 \tag{3.1.6}$$

if

$$w = \frac{\partial u}{\partial t} + c \frac{\partial u}{\partial x}. \tag{3.1.7}$$

The only difference between (3.1.5) and (3.1.6) is the sign of the second term. We now show how to solve (3.1.5) which is called the first order wave equation or advection equation (in Meteorology).

Remark: Although (3.1.4)-(3.1.5) or (3.1.6)-(3.1.7) can be used to solve the one dimensional second order wave equation (3.1.1) , we will see in section 3.3 another way to solve (3.1.1) based on the results of Chapter 2.

To solve (3.1.5) we note that if we consider an observer moving on a curve  $x(t)$  then by the chain rule we get

$$\frac{dv(x(t), t)}{dt} = \frac{\partial v}{\partial t} + \frac{\partial v}{\partial x} \frac{dx}{dt}. \quad (3.1.8)$$

If the observer is moving at a rate  $\frac{dx}{dt} = c$ , then by comparing (3.1.8) and (3.1.5) we find

$$\frac{dv}{dt} = 0. \quad (3.1.9)$$

Therefore (3.1.5) can be replaced by a set of two ODEs

$$\frac{dx}{dt} = c, \quad (3.1.10)$$

$$\frac{dv}{dt} = 0. \quad (3.1.11)$$

These 2 ODEs are easy to solve. Integration of (3.1.10) yields

$$x(t) = x(0) + ct \quad (3.1.12)$$

and the other one has a solution

$$v = \text{constant along the curve given in (3.1.12)}.$$

The curve (3.1.12) is a straight line. In fact, we have a family of parallel straight lines, called characteristics, see figure 8.

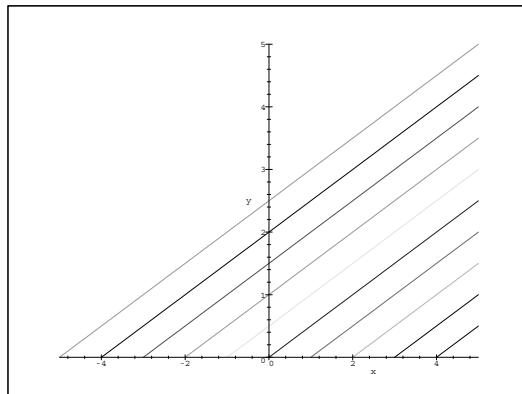

Figure 8: Characteristics  $t = \frac{1}{c}x - \frac{1}{c}x(0)$

In order to obtain the general solution of the one dimensional equation (3.1.5) subject to the initial value

$$v(x(0), 0) = f(x(0)), \quad (3.1.13)$$

we note that

$$v = \text{constant along } x(t) = x(0) + ct$$

but that constant is  $f(x(0))$  from (3.1.13). Since  $x(0) = x(t) - ct$ , the general solution is then

$$v(x, t) = f(x(t) - ct). \quad (3.1.14)$$

Let us show that (3.1.14) is the solution. First if we take  $t = 0$ , then (3.1.14) reduces to

$$v(x, 0) = f(x(0) - c \cdot 0) = f(x(0)).$$

To check the PDE we require the first partial derivatives of  $v$ . Notice that  $f$  is a function of only one variable, i.e. of  $x - ct$ . Therefore

$$\begin{aligned} \frac{\partial v}{\partial t} &= \frac{df(x-ct)}{dt} = \frac{df}{d(x-ct)} \frac{d(x-ct)}{dt} = -c \frac{df}{d(x-ct)} \\ \frac{\partial v}{\partial x} &= \frac{df(x-ct)}{dx} = \frac{df}{d(x-ct)} \frac{d(x-ct)}{dx} = 1 \frac{df}{d(x-ct)}. \end{aligned}$$

Substituting these two derivatives in (3.1.5) we see that the equation is satisfied.

### Example 1

$$\frac{\partial v}{\partial t} + 3 \frac{\partial v}{\partial x} = 0 \quad (3.1.15)$$

$$v(x, 0) = \begin{cases} \frac{1}{2}x & 0 < x < 1 \\ 0 & \text{otherwise.} \end{cases} \quad (3.1.16)$$

The two ODEs are

$$\frac{dx}{dt} = 3, \quad (3.1.17)$$

$$\frac{dv}{dt} = 0. \quad (3.1.18)$$

The solution of (3.1.17) is

$$x(t) = x(0) + 3t \quad (3.1.19)$$

and the solution of (3.1.18) is

$$v(x(t), t) = v(x(0), 0) = \text{constant}. \quad (3.1.20)$$

Using (3.1.16) the solution is then

$$v(x(t), t) = \begin{cases} \frac{1}{2}x(0) & 0 < x(0) < 1 \\ 0 & \text{otherwise.} \end{cases}$$

Substituting  $x(0)$  from (3.1.19) we have

$$v(x, t) = \begin{cases} \frac{1}{2}(x - 3t) & 0 < x - 3t < 1 \\ 0 & \text{otherwise.} \end{cases} \quad (3.1.21)$$

The interpretation of (3.1.20) is as follows. Given a point  $x$  at time  $t$ , find the characteristic through this point. Move on the characteristic to find the point  $x(0)$  and then use the initial value at that  $x(0)$  as the solution at  $(x, t)$ . (Recall that  $v$  is constant along a characteristic.)



Let's sketch the characteristics through the points  $x = 0, 1$  (see (3.1.19) and Figure 9.)

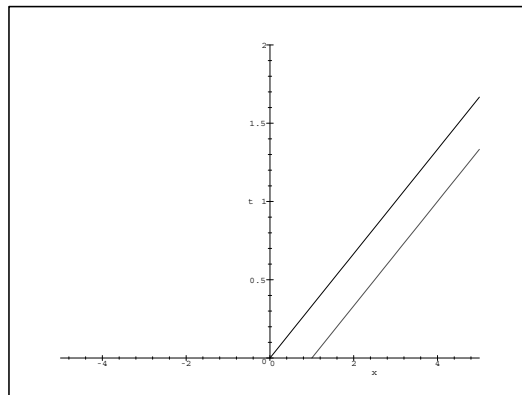

Figure 9: 2 characteristics for  $x(0) = 0$  and  $x(0) = 1$

The initial solution is sketched in figure 10

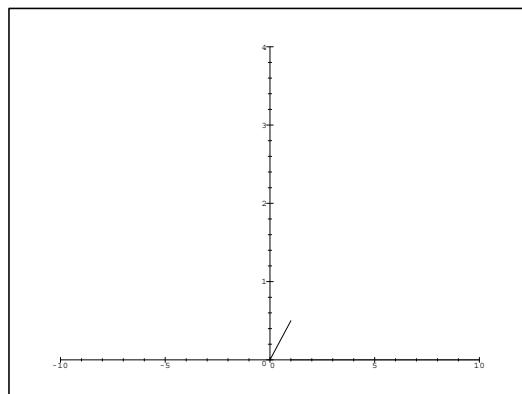

Figure 10: Solution at time  $t = 0$

This shape is constant along a characteristic, and moving at the rate of 3 units. For example, the point  $x = \frac{1}{2}$  at time  $t = 0$  will be at  $x = 3.5$  at time  $t = 1$ . The solution  $v$  will be exactly the same at both points, namely  $v = \frac{1}{4}$ . The solution at several times is given in figure 11.

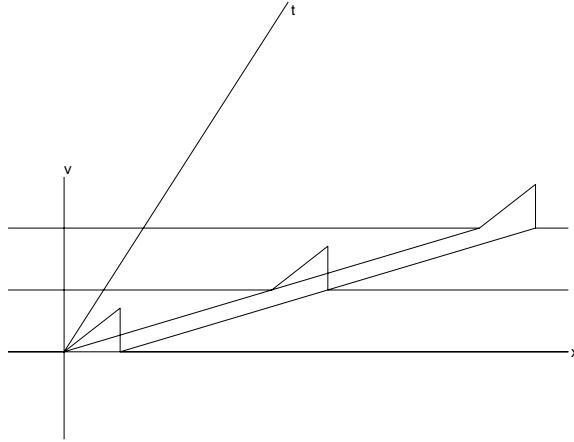

Figure 11: Solution at several times

Example 2

$$\frac{\partial u}{\partial t} - 2\frac{\partial u}{\partial x} = e^{2x} \quad (3.1.22)$$

$$u(x, 0) = f(x). \quad (3.1.23)$$

The system of ODEs is

$$\frac{du}{dt} = e^{2x} \quad (3.1.24)$$

$$\frac{dx}{dt} = -2. \quad (3.1.25)$$

Solve (3.1.25) to get the characteristic curve

$$x(t) = x(0) - 2t. \quad (3.1.26)$$

Substituting the characteristic equation in (3.1.24) yields

$$\frac{du}{dt} = e^{2(x(0)-2t)}.$$

Thus

$$\begin{aligned} du &= e^{2x(0)-4t} dt \\ u &= K - \frac{1}{4}e^{2x(0)-4t}. \end{aligned} \quad (3.1.27)$$

At  $t = 0$

$$f(x(0)) = u(x(0), 0) = K - \frac{1}{4}e^{2x(0)}$$

and therefore

$$K = f(x(0)) + \frac{1}{4}e^{2x(0)}. \quad (3.1.28)$$

Substitute  $K$  in (3.1.27) we have

$$u(x, t) = f(x(0)) + \frac{1}{4}e^{2x(0)} - \frac{1}{4}e^{2x(0)-4t}.$$

Now substitute for  $x(0)$  from (3.1.26) we get

$$u(x, t) = f(x + 2t) + \frac{1}{4}e^{2(x+2t)} - \frac{1}{4}e^{2x},$$

or

$$u(x, t) = f(x + 2t) + \frac{1}{4}e^{2x} (e^{4t} - 1). \quad (3.1.29)$$

Note that the first term on the right is the solution of the homogeneous equation and the second term is a result of the inhomogeneity.

### 3.1.1 Numerical Solution

Here we discuss a general linear first order hyperbolic

$$a(x, t)u_x + b(x, t)u_t = c(x, t)u + d(x, t). \quad (3.1.1)$$

Note that since  $b(x, t)$  may vanish, we cannot in general divide the equation by  $b(x, t)$  to get it in the same form as we had before. Thus we parametrize  $x$  and  $t$  in terms of a parameter  $s$ , and instead of taking the curve  $x(t)$ , we write it as  $x(s), t(s)$ .

The characteristic equation is now a system

$$\frac{dx}{ds} = a(x(s), t(s)) \quad (3.1.2)$$

$$x(0) = \xi \quad (3.1.3)$$

$$\frac{dt}{ds} = b(x(s), t(s)) \quad (3.1.4)$$

$$t(0) = 0 \quad (3.1.5)$$

$$\frac{du}{ds} = c(x(s), t(s))u(x(s), t(s)) + d(x(s), t(s)) \quad (3.1.6)$$

$$u(\xi, 0) = f(\xi) \quad (3.1.7)$$

This system of ODEs need to be solved numerically. One possibility is the use of Runge-Kutta method. This idea can also be used for quasilinear hyperbolic PDEs.

## Problems

1. Solve

$$\frac{\partial w}{\partial t} - 3\frac{\partial w}{\partial x} = 0$$

subject to

$$w(x, 0) = \sin x$$

2. Solve using the method of characteristics

a.  $\frac{\partial u}{\partial t} + c\frac{\partial u}{\partial x} = e^{2x}$  subject to  $u(x, 0) = f(x)$

b.  $\frac{\partial u}{\partial t} + x\frac{\partial u}{\partial x} = 1$  subject to  $u(x, 0) = f(x)$

c.  $\frac{\partial u}{\partial t} + 3t\frac{\partial u}{\partial x} = u$  subject to  $u(x, 0) = f(x)$

d.  $\frac{\partial u}{\partial t} - 2\frac{\partial u}{\partial x} = e^{2x}$  subject to  $u(x, 0) = \cos x$

e.  $\frac{\partial u}{\partial t} - t^2\frac{\partial u}{\partial x} = -u$  subject to  $u(x, 0) = 3e^x$

3. Show that the characteristics of

$$\frac{\partial u}{\partial t} + 2u\frac{\partial u}{\partial x} = 0$$

$$u(x, 0) = f(x)$$

are straight lines.

4. Consider the problem

$$\frac{\partial u}{\partial t} + 2u\frac{\partial u}{\partial x} = 0$$

$$u(x, 0) = f(x) = \begin{cases} 1 & x < 0 \\ 1 + \frac{x}{L} & 0 < x < L \\ 2 & L < x \end{cases}$$

- Determine equations for the characteristics
- Determine the solution  $u(x, t)$
- Sketch the characteristic curves.
- Sketch the solution  $u(x, t)$  for fixed  $t$ .

## 3.2 Quasilinear Equations

The method of characteristics is the only method applicable for quasilinear PDEs. All other methods such as separation of variables, Green's functions, Fourier or Laplace transforms cannot be extended to quasilinear problems.

In this section, we describe the use of the method of characteristics for the solution of

$$\frac{\partial u}{\partial t} + c(u, x, t) \frac{\partial u}{\partial x} = S(u, x, t) \quad (3.2.1)$$

$$u(x, 0) = f(x). \quad (3.2.2)$$

Such problems have applications in gas dynamics or traffic flow.

Equation (3.2.1) can be rewritten as a system of ODEs

$$\frac{dx}{dt} = c(u, x, t) \quad (3.2.3)$$

$$\frac{du}{dt} = S(u, x, t). \quad (3.2.4)$$

The first equation is the characteristic equation. The solution of this system can be very complicated since  $u$  appears nonlinearly in both. To find the characteristic curve one must know the solution. Geometrically, the characteristic curve has a slope depending on the solution  $u$  at that point, see figure 12.

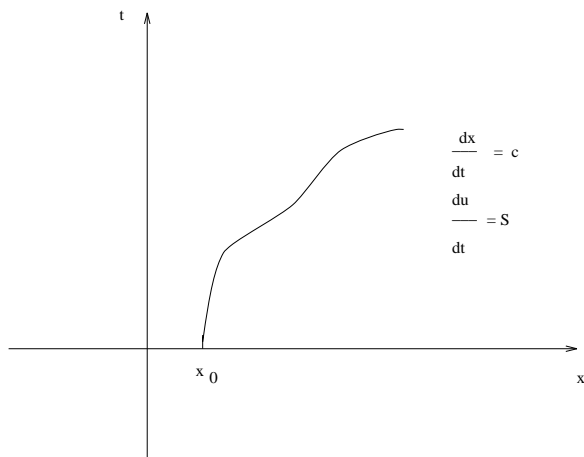

Figure 12:  $u(x_0, 0) = f(x_0)$

The slope of the characteristic curve at  $x_0$  is

$$\frac{1}{c(u(x_0), x_0, 0)} = \frac{1}{c(f(x_0), x_0, 0)}. \quad (3.2.5)$$

Now we can compute the next point on the curve, by using this slope (assuming a slow change of rate and that the point is close to the previous one). Once we have the point, we can then solve for  $u$  at that point.

### 3.2.1 The Case $S = 0$ , $c = c(u)$

The quasilinear equation

$$u_t + c(u)u_x = 0 \quad (3.2.1.1)$$

subject to the initial condition

$$u(x, 0) = f(x) \quad (3.2.1.2)$$

is equivalent to

$$\frac{dx}{dt} = c(u) \quad (3.2.1.3)$$

$$x(0) = \xi \quad (3.2.1.4)$$

$$\frac{du}{dt} = 0 \quad (3.2.1.5)$$

$$u(\xi, 0) = f(\xi). \quad (3.2.1.6)$$

Thus

$$u(x, t) = u(\xi, 0) = f(\xi) \quad (3.2.1.7)$$

$$\frac{dx}{dt} = c(f(\xi))$$

$$x = tc(f(\xi)) + \xi. \quad (3.2.1.8)$$

Solve (3.2.1.8) for  $\xi$  and substitute in (3.2.1.7) to get the solution.

To check our solution, we compute the first partial derivatives of  $u$

$$\frac{\partial u}{\partial t} = \frac{du}{d\xi} \frac{d\xi}{dt}$$

$$\frac{\partial u}{\partial x} = \frac{du}{d\xi} \frac{d\xi}{dx}.$$

Differentiating (3.2.1.8) with respect to  $x$  and  $t$  we have

$$1 = tc'(f(\xi))f'(\xi)\xi_x + \xi_x$$

$$0 = c(f(\xi)) + tc'(f(\xi))f'(\xi)\xi_t + \xi_t$$

correspondingly.

Thus when recalling that  $\frac{du}{d\xi} = f'(\xi)$

$$u_t = -\frac{c(f(\xi))}{1 + tc'(f(\xi))f'(\xi)}f'(\xi) \quad (3.2.1.9)$$

$$u_x = \frac{1}{1 + tc'(f(\xi))f'(\xi)}f'(\xi). \quad (3.2.1.10)$$

Substituting these expressions in (3.2.1.1) results in an identity. The initial condition (3.2.1.2) is exactly (3.2.1.7).

### Example 3

$$\frac{\partial u}{\partial t} + u \frac{\partial u}{\partial x} = 0 \quad (3.2.1.11)$$

$$u(x, 0) = 3x. \quad (3.2.1.12)$$

The equivalent system of ODEs is

$$\frac{du}{dt} = 0 \quad (3.2.1.13)$$

$$\frac{dx}{dt} = u. \quad (3.2.1.14)$$

Solving the first one yields

$$u(x, t) = u(x(0), 0) = 3x(0). \quad (3.2.1.15)$$

Substituting this solution in (3.2.1.14)

$$\frac{dx}{dt} = 3x(0)$$

which has a solution

$$x = 3x(0)t + x(0). \quad (3.2.1.16)$$

Solve (3.2.1.16) for  $x(0)$  and substitute in (3.2.1.15) gives

$$u(x, t) = \frac{3x}{3t + 1}. \quad (3.2.1.17)$$

### 3.2.2 Graphical Solution

Graphically, one can obtain the solution as follows:

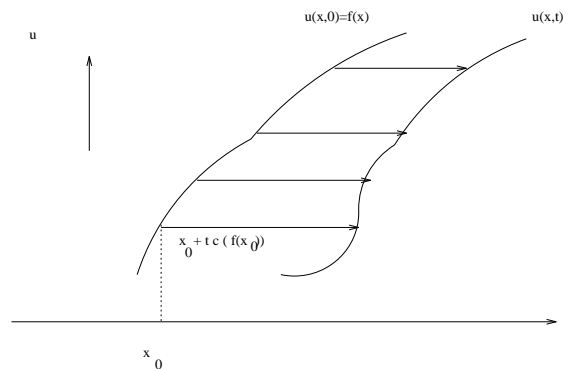

Figure 13: Graphical solution

Suppose the initial solution  $u(x, 0)$  is sketched as in figure 13. We know that each  $u(x_0)$  stays constant moving at its own constant speed  $c(u(x_0))$ . At time  $t$ , it moved from  $x_0$  to  $x_0 + tc(f(x_0))$  (horizontal arrow). This process should be carried out to enough points on the initial curve to get the solution at time  $t$ . Note that the lengths of the arrows are different and depend on  $c$ .

## Problems

1. Solve the following

a.  $\frac{\partial u}{\partial t} = 0$  subject to  $u(x, 0) = g(x)$

b.  $\frac{\partial u}{\partial t} = -3xu$  subject to  $u(x, 0) = g(x)$

2. Solve

$$\frac{\partial u}{\partial t} = u$$

subject to

$$u(x, t) = 1 + \cos x \quad \text{along} \quad x + 2t = 0$$

3. Let

$$\frac{\partial u}{\partial t} + c \frac{\partial u}{\partial x} = 0 \quad c = \text{constant}$$

a. Solve the equation subject to  $u(x, 0) = \sin x$

b. If  $c > 0$ , determine  $u(x, t)$  for  $x > 0$  and  $t > 0$  where

$$\begin{aligned} u(x, 0) &= f(x) && \text{for } x > 0 \\ u(0, t) &= g(t) && \text{for } t > 0 \end{aligned}$$

4. Solve the following linear equations subject to  $u(x, 0) = f(x)$

a.  $\frac{\partial u}{\partial t} + c \frac{\partial u}{\partial x} = e^{-3x}$

b.  $\frac{\partial u}{\partial t} + t \frac{\partial u}{\partial x} = 5$

c.  $\frac{\partial u}{\partial t} - t^2 \frac{\partial u}{\partial x} = -u$

d.  $\frac{\partial u}{\partial t} + x \frac{\partial u}{\partial x} = t$

e.  $\frac{\partial u}{\partial t} + x \frac{\partial u}{\partial x} = x$

5. Determine the parametric representation of the solution satisfying  $u(x, 0) = f(x)$ ,

a.  $\frac{\partial u}{\partial t} - u^2 \frac{\partial u}{\partial x} = 3u$



b.  $\frac{\partial u}{\partial t} + t^2 u \frac{\partial u}{\partial x} = -u$

6. Solve

$$\frac{\partial u}{\partial t} + t^2 u \frac{\partial u}{\partial x} = 5$$

subject to

$$u(x, 0) = x.$$

### 3.2.3 Fan-like Characteristics

Since the slope of the characteristic,  $\frac{1}{c}$ , depends in general on the solution, one may have characteristic curves intersecting or curves that fan-out. We demonstrate this by the following example.

#### Example 4

$$u_t + uu_x = 0 \tag{3.2.3.1}$$

$$u(x, 0) = \begin{cases} 1 & \text{for } x < 0 \\ 2 & \text{for } x > 0. \end{cases} \tag{3.2.3.2}$$

The system of ODEs is

$$\frac{dx}{dt} = u, \tag{3.2.3.3}$$

$$\frac{du}{dt} = 0. \tag{3.2.3.4}$$

The second ODE satisfies

$$u(x, t) = u(x(0), 0) \tag{3.2.3.5}$$

and thus the characteristics are

$$x = u(x(0), 0)t + x(0) \tag{3.2.3.6}$$

or

$$x(t) = \begin{cases} t + x(0) & \text{if } x(0) < 0 \\ 2t + x(0) & \text{if } x(0) > 0. \end{cases} \tag{3.2.3.7}$$

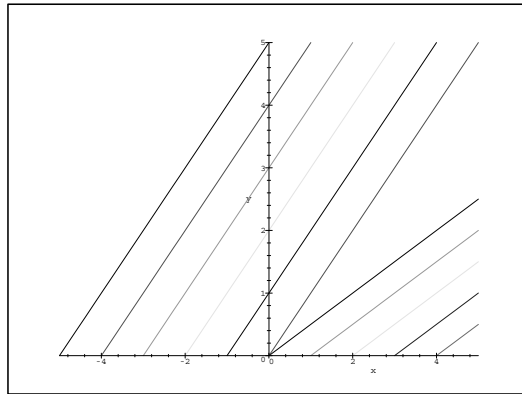

Figure 14: The characteristics for Example 4

Let's sketch those characteristics (Figure 14). If we start with a negative  $x(0)$  we obtain a straight line with slope 1. If  $x(0)$  is positive, the slope is  $\frac{1}{2}$ .

Since  $u(x(0), 0)$  is discontinuous at  $x(0) = 0$ , we find there are no characteristics through  $t = 0, x(0) = 0$ . In fact,<sup>1</sup> we imagine that there are infinitely many characteristics with all possible slopes from  $\frac{1}{2}$  to 1. Since the characteristics fan out from  $x = t$  to  $x = 2t$  we call these fan-like characteristics. The solution for  $t < x < 2t$  will be given by (3.2.3.6) with  $x(0) = 0$ , i.e.

$$x = ut$$

or

$$u = \frac{x}{t} \quad \text{for} \quad t < x < 2t. \quad (3.2.3.8)$$

To summarize the solution is then

$$u = \begin{cases} 1 & x(0) = x - t < 0 \\ 2 & x(0) = x - 2t > 0 \\ \frac{x}{t} & t < x < 2t \end{cases} \quad (3.2.3.9)$$

The sketch of the solution is given in figure 15.

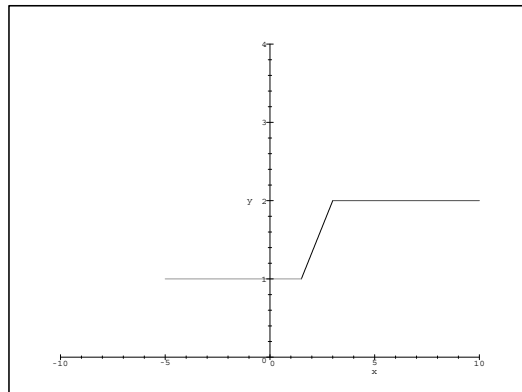

Figure 15: The solution of Example 4

### 3.2.4 Shock Waves

If the initial solution is discontinuous, but the value to the left is larger than that to the right, one will see intersecting characteristics.

#### Example 5

$$u_t + uu_x = 0 \quad (3.2.4.1)$$

$$u(x, 0) = \begin{cases} 2 & x < 1 \\ 1 & x > 1. \end{cases} \quad (3.2.4.2)$$

---

<sup>1</sup> $u = x/t$  is a general solution which only exists for  $t \neq 0$ . This is called rarefaction because it seems like fanning out from the point of discontinuity (inviscid Burgers' equation).

The solution is as in the previous example, i.e.

$$x(t) = u(x(0), 0)t + x(0) \quad (3.2.4.3)$$

$$x(t) = \begin{cases} 2t + x(0) & \text{if } x(0) < 1 \\ t + x(0) & \text{if } x(0) > 1. \end{cases} \quad (3.2.4.4)$$

The sketch of the characteristics is given in figure16.

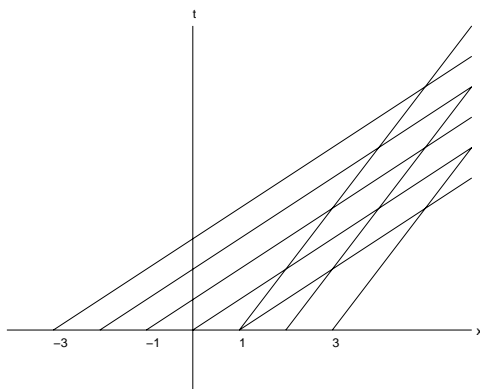

Figure 16: Intersecting characteristics

Since there are two characteristics through a point, one cannot tell on which characteristic to move back to  $t = 0$  to obtain the solution. In other words, at points of intersection the solution  $u$  is multi-valued. This situation happens whenever the speed along the characteristic on the left is larger than the one along the characteristic on the right, and thus catching up with it. We say in this case to have a shock wave. Let  $x_1(0) < x_2(0)$  be two points at  $t = 0$ , then

$$\begin{aligned} x_1(t) &= c(f(x_1(0)))t + x_1(0) \\ x_2(t) &= c(f(x_2(0)))t + x_2(0). \end{aligned} \quad (3.2.4.5)$$

If  $c(f(x_1(0))) > c(f(x_2(0)))$  then the characteristics emanating from  $x_1(0)$ ,  $x_2(0)$  will intersect. Suppose the points are close, i.e.  $x_2(0) = x_1(0) + \Delta x$ , then to find the point of intersection we equate  $x_1(t) = x_2(t)$ . Solving this for  $t$  yields

$$t = \frac{-\Delta x}{-c(f(x_1(0))) + c(f(x_1(0) + \Delta x))}. \quad (3.2.4.6)$$

If we let  $\Delta x$  tend to zero, the denominator (after dividing through by  $\Delta x$ ) tends to the derivative of  $c$ , i.e.

$$t = -\frac{1}{\frac{dc(f(x_1(0)))}{dx_1(0)}}. \quad (3.2.4.7)$$

Since  $t$  must be positive at intersection (we measure time from zero), this means that

$$\frac{dc}{dx_1} < 0. \quad (3.2.4.8)$$

So if the characteristic velocity  $c$  is locally decreasing then the characteristics will intersect. This is more general than the case in the last example where we have a discontinuity in the initial solution. One can have a continuous initial solution  $u(x, 0)$  and still get a shock wave. Note that (3.2.4.7) implies that

$$1 + t \frac{dc(f)}{dx} = 0$$

which is exactly the denominator in the first partial derivative of  $u$  (see (3.2.1.9)-(3.2.1.10)).

Example 6

$$u_t + uu_x = 0 \tag{3.2.4.9}$$

$$u(x, 0) = -x. \tag{3.2.4.10}$$

The solution of the ODEs

$$\frac{du}{dt} = 0, \tag{3.2.4.11}$$

$$\frac{dx}{dt} = u,$$

is

$$u(x, t) = u(x(0), 0) = -x(0), \tag{3.2.4.12}$$

$$x(t) = -x(0)t + x(0) = x(0)(1 - t). \tag{3.2.4.13}$$

Solving for  $x(0)$  and substituting in (3.2.4.12) yields

$$u(x, t) = -\frac{x(t)}{1 - t}. \tag{3.2.4.14}$$

This solution is undefined at  $t = 1$ . If we use (3.2.4.7) we get exactly the same value for  $t$ , since

$$f(x_0) = -x_0 \quad (\text{from (3.2.4.10)})$$

$$c(f(x_0)) = u(x_0) = -x_0 \quad (\text{from (3.2.4.9)})$$

$$\frac{dc}{dx_0} = -1$$

$$t = -\frac{1}{-1} = 1.$$

In the next figure we sketch the characteristics given by (3.2.4.13). It is clear that all characteristics intersect at  $t = 1$ . The shock wave starts at  $t = 1$ . If the initial solution is discontinuous then the shock wave is formed immediately.

How do we find the shock position  $x_s(t)$  and its speed? To this end, we rewrite the original equation in conservation law form, i.e.

$$u_t + \frac{\partial}{\partial x} q(u) = 0 \tag{3.2.4.15}$$

or

$$\int_{\alpha}^{\beta} u_t dx = \frac{d}{dt} \int_{\alpha}^{\beta} u dx = -q|_{\alpha}^{\beta}.$$

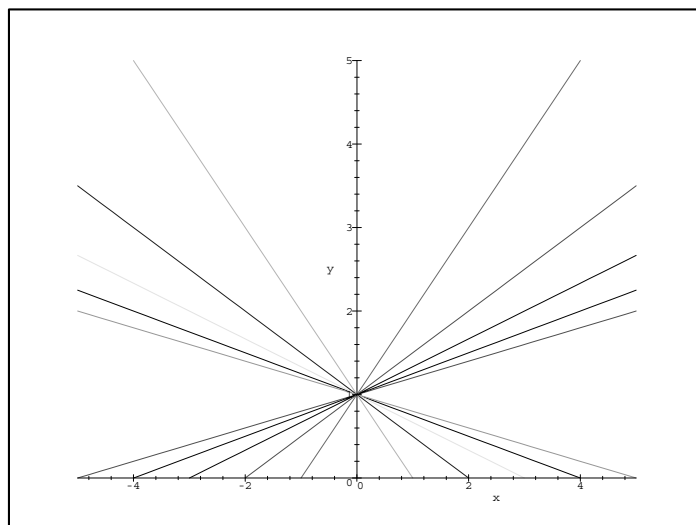

Figure 17: Sketch of the characteristics for Example 6

This is equivalent to the quasilinear equation (3.2.4.9) if  $q(u) = \frac{1}{2}u^2$ .

The terms “conservative form”, “conservation-law form”, “weak form” or “divergence form” are all equivalent. PDEs having this form have the property that the coefficients of the derivative term are either constant or, if variable, their derivatives appear nowhere in the equation. Normally, for PDEs to represent a physical conservation statement, this means that the divergence of a physical quantity can be identified in the equation. For example, the conservation form of the one-dimensional heat equation for a substance whose density,  $\rho$ , specific heat,  $c$ , and thermal conductivity  $K$ , all vary with position is

$$\rho c \frac{\partial u}{\partial t} = \frac{\partial}{\partial x} \left( K \frac{\partial u}{\partial x} \right)$$

whereas a nonconservative form would be

$$\rho c \frac{\partial u}{\partial t} = \frac{\partial K}{\partial x} \frac{\partial u}{\partial x} + K \frac{\partial^2 u}{\partial x^2}.$$

In the conservative form, the right hand side can be identified as the negative of the divergence of the heat flux (see Chapter 1).

Consider a discontinuous initial condition, then the equation must be taken in the integral form (3.2.4.15). We seek a solution  $u$  and a curve  $x = x_s(t)$  across which  $u$  may have a jump. Suppose that the left and right limits are

$$\begin{aligned} \lim_{x \rightarrow x_s(t)^-} u(x, t) &= u_\ell \\ \lim_{x \rightarrow x_s(t)^+} u(x, t) &= u_r \end{aligned} \tag{3.2.4.16}$$

and define the jump across  $x_s(t)$  by

$$[u] = u_r - u_\ell. \tag{3.2.4.17}$$

Let  $[\alpha, \beta]$  be any interval containing  $x_s(t)$  at time  $t$ . Then

$$\frac{d}{dt} \int_{\alpha}^{\beta} u(x, t) dx = - [q(u(\beta, t)) - q(u(\alpha, t))]. \quad (3.2.4.18)$$

However the left hand side is

$$\frac{d}{dt} \int_{\alpha}^{x_s(t)^-} u dx + \frac{d}{dt} \int_{x_s(t)^+}^{\beta} u dx = \int_{\alpha}^{x_s(t)^-} u_t dx + \int_{x_s(t)^+}^{\beta} u_t dx + u_{\ell} \frac{dx_s}{dt} - u_r \frac{dx_s}{dt}. \quad (3.2.4.19)$$

Recall the rule to differentiate a definite integral when one of the endpoints depends on the variable of differentiation, i.e.

$$\frac{d}{dt} \int_a^{\phi(t)} u(x, t) dx = \int_a^{\phi(t)} u_t(x, t) dx + u(\phi(t), t) \frac{d\phi}{dt}.$$

Since  $u_t$  is bounded in each of the intervals separately, the integrals on the right hand side of (3.2.4.19) tend to zero as  $\alpha \rightarrow x_s^-$  and  $\beta \rightarrow x_s^+$ . Thus

$$[u] \frac{dx_s}{dt} = [q].$$

This gives the characteristic equation for shocks

$$\frac{dx_s}{dt} = \frac{[q]}{[u]}. \quad (3.2.4.20)$$

Going back to the example (3.2.4.1)-(3.2.4.2) we find from (3.2.4.1) that

$$q = \frac{1}{2} u^2$$

and from (3.2.4.2)

$$\begin{aligned} u_{\ell} &= 2, \\ u_r &= 1. \end{aligned}$$

Therefore

$$\begin{aligned} \frac{dx_s}{dt} &= \frac{\frac{1}{2} \cdot 1^2 - \frac{1}{2} \cdot 2^2}{1 - 2} = \frac{-2 + \frac{1}{2}}{-1} = \frac{3}{2} \\ x_s(0) &= 1 \quad (\text{where discontinuity starts}). \end{aligned}$$

The solution is then

$$x_s = \frac{3}{2} t + 1. \quad (3.2.4.21)$$

We can now sketch this along with the other characteristics in figure 18. Any characteristic reaching the one given by (3.2.4.21) will stop there. The solution is given in figure 19.

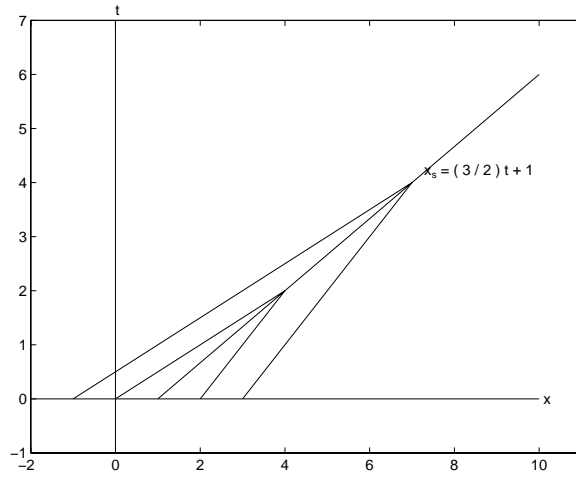

Figure 18: Shock characteristic for Example 5

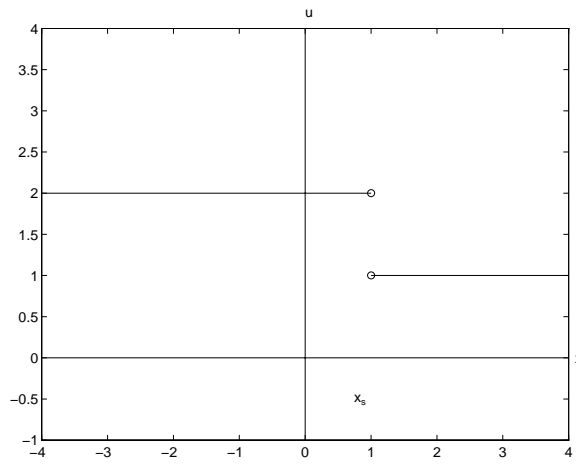

Figure 19: Solution of Example 5



## Problems

1. Consider Burgers' equation

$$\frac{\partial \rho}{\partial t} + u_{max} \left[ 1 - \frac{2\rho}{\rho_{max}} \right] \frac{\partial \rho}{\partial x} = \nu \frac{\partial^2 \rho}{\partial x^2}$$

Suppose that a solution exists as a density wave moving without change of shape at a velocity  $V$ ,  $\rho(x, t) = f(x - Vt)$ .

a. What ordinary differential equation is satisfied by  $f$

b. Show that the velocity of wave propagation,  $V$ , is the same as the shock velocity separating  $\rho = \rho_1$  from  $\rho = \rho_2$  (occurring if  $\nu = 0$ ).

2. Solve

$$\frac{\partial \rho}{\partial t} + \rho^2 \frac{\partial \rho}{\partial x} = 0$$

subject to

$$\rho(x, 0) = \begin{cases} 4 & x < 0 \\ 3 & x > 0 \end{cases}$$

3. Solve

$$\frac{\partial u}{\partial t} + 4u \frac{\partial u}{\partial x} = 0$$

subject to

$$u(x, 0) = \begin{cases} 3 & x < 1 \\ 2 & x > 1 \end{cases}$$

4. Solve the above equation subject to

$$u(x, 0) = \begin{cases} 2 & x < -1 \\ 3 & x > -1 \end{cases}$$

5. Solve the quasilinear equation

$$\frac{\partial u}{\partial t} + u \frac{\partial u}{\partial x} = 0$$

subject to

$$u(x, 0) = \begin{cases} 2 & x < 2 \\ 3 & x > 2 \end{cases}$$

6. Solve the quasilinear equation

$$\frac{\partial u}{\partial t} + u \frac{\partial u}{\partial x} = 0$$

subject to

$$u(x, 0) = \begin{cases} 0 & x < 0 \\ x & 0 \leq x < 1 \\ 1 & 1 \leq x \end{cases}$$

7. Solve the inviscid Burgers' equation

$$u_t + uu_x = 0$$

$$u(x, 0) = \begin{cases} 2 & \text{for } x < 0 \\ 1 & \text{for } 0 < x < 1 \\ 0 & \text{for } x > 1 \end{cases}$$

Note that two shocks start at  $t = 0$ , and eventually intersect to create a third shock. Find the solution for all time (analytically), and graphically display your solution, labeling all appropriate bounding curves.

### 3.3 Second Order Wave Equation

In this section we show how the method of characteristics is applied to solve the second order wave equation describing a vibrating string. The equation is

$$u_{tt} - c^2 u_{xx} = 0, \quad c = \text{constant}. \quad (3.3.1)$$

For the rest of this chapter the unknown  $u(x, t)$  describes the displacement from rest of every point  $x$  on the string at time  $t$ . We have shown in section 2.3 that the general solution is

$$u(x, t) = F(x - ct) + G(x + ct). \quad (3.3.2)$$

#### 3.3.1 Infinite Domain

The problem is to find the solution of (3.3.1) subject to the initial conditions

$$u(x, 0) = f(x) \quad -\infty < x < \infty \quad (3.3.1.1)$$

$$u_t(x, 0) = g(x) \quad -\infty < x < \infty. \quad (3.3.1.2)$$

These conditions will specify the arbitrary functions  $F, G$ . Combining the conditions with (3.3.2), we have

$$F(x) + G(x) = f(x) \quad (3.3.1.3)$$

$$-c \frac{dF}{dx} + c \frac{dG}{dx} = g(x). \quad (3.3.1.4)$$

These are two equations for the two arbitrary functions  $F$  and  $G$ . In order to solve the system, we first integrate (3.3.1.4), thus

$$-F(x) + G(x) = \frac{1}{c} \int_0^x g(\xi) d\xi. \quad (3.3.1.5)$$

Therefore, the solution of (3.3.1.3) and (3.3.1.5) is

$$F(x) = \frac{1}{2} f(x) - \frac{1}{2c} \int_0^x g(\xi) d\xi, \quad (3.3.1.6)$$

$$G(x) = \frac{1}{2} f(x) + \frac{1}{2c} \int_0^x g(\xi) d\xi. \quad (3.3.1.7)$$

Combining these expressions with (3.3.2), we have

$$u(x, t) = \frac{f(x + ct) + f(x - ct)}{2} + \frac{1}{2c} \int_{x-ct}^{x+ct} g(\xi) d\xi. \quad (3.3.1.8)$$

This is d'Alembert's solution to (3.3.1) subject to (3.3.1.1)-(3.3.1.2).

Note that the solution  $u$  at a point  $(x_0, t_0)$  depends on  $f$  at the points  $(x_0 + ct_0, 0)$  and  $(x_0 - ct_0, 0)$ , and on the values of  $g$  on the interval  $(x_0 - ct_0, x_0 + ct_0)$ . This interval is called

domain of dependence. In figure 20, we see that the domain of dependence is obtained by drawing the two characteristics

$$x - ct = x_0 - ct_0$$

$$x + ct = x_0 + ct_0$$

through the point  $(x_0, t_0)$ . This behavior is to be expected because the effects of the initial data propagate at the finite speed  $c$ . Thus the only part of the initial data that can influence the solution at  $x_0$  at time  $t_0$  must be within  $ct_0$  units of  $x_0$ . This is precisely the data given in the interval  $(x_0 - ct_0, x_0 + ct_0)$ .

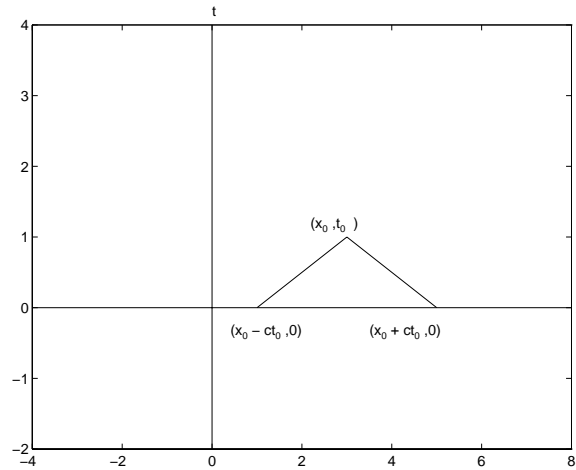

Figure 20: Domain of dependence

The functions  $f(x)$ ,  $g(x)$  describing the initial position and speed of the string are defined for all  $x$ . The initial disturbance  $f(x)$  at a point  $x_1$  will propagate at speed  $c$  whereas the effect of the initial velocity  $g(x)$  propagates at all speeds up to  $c$ . This infinite sector (figure 21) is called the domain of influence of  $x_1$ .

The solution (3.3.2) represents a sum of two waves, one is travelling at a speed  $c$  to the right ( $F(x - ct)$ ) and the other is travelling to the left at the same speed.

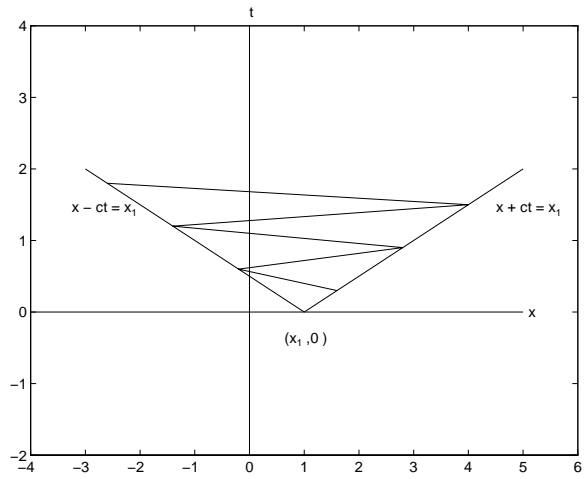

Figure 21: Domain of influence

## Problems

1. Suppose that

$$u(x, t) = F(x - ct).$$

Evaluate

a.  $\frac{\partial u}{\partial t}(x, 0)$

b.  $\frac{\partial u}{\partial x}(0, t)$

2. The general solution of the one dimensional wave equation

$$u_{tt} - 4u_{xx} = 0$$

is given by

$$u(x, t) = F(x - 2t) + G(x + 2t).$$

Find the solution subject to the initial conditions

$$u(x, 0) = \cos x \quad -\infty < x < \infty,$$

$$u_t(x, 0) = 0 \quad -\infty < x < \infty.$$

3. In section 3.1, we suggest that the wave equation can be written as a system of two first order PDEs. Show how to solve

$$u_{tt} - c^2u_{xx} = 0$$

using that idea.

### 3.3.2 Semi-infinite String

The problem is to solve the one-dimensional wave equation

$$u_{tt} - c^2 u_{xx} = 0, \quad 0 \leq x < \infty, \quad (3.3.2.1)$$

subject to the initial conditions

$$u(x, 0) = f(x), \quad 0 \leq x < \infty, \quad (3.3.2.2)$$

$$u_t(x, 0) = g(x), \quad 0 \leq x < \infty, \quad (3.3.2.3)$$

and the boundary condition

$$u(0, t) = h(t), \quad 0 \leq t. \quad (3.3.2.4)$$

Note that  $f(x)$  and  $g(x)$  are defined only for nonnegative  $x$ . Therefore, the solution (3.3.1.8) holds only if the arguments of  $f(x)$  are nonnegative, i.e.

$$\begin{aligned} x - ct &\geq 0 \\ x + ct &\geq 0 \end{aligned} \quad (3.3.2.5)$$

As can be seen in figure 22, the first quadrant must be divided to two sectors by the characteristic  $x - ct = 0$ . In the lower sector I, the solution (3.3.1.8) holds. In the other sector, one should note that a characteristic  $x - ct = K$  will cross the negative  $x$  axis and the positive  $t$  axis.

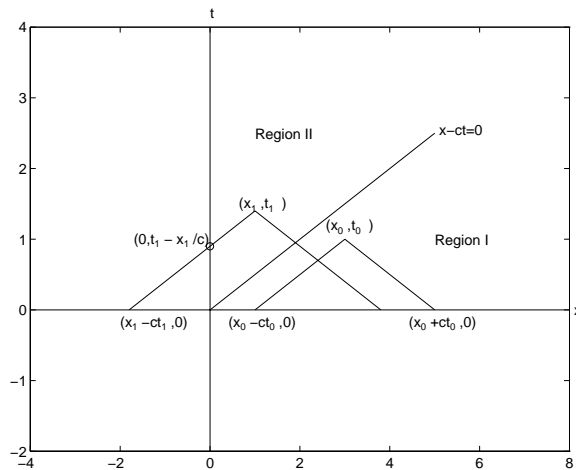

Figure 22: The characteristic  $x - ct = 0$  divides the first quadrant

The solution at point  $(x_1, t_1)$  must depend on the boundary condition  $h(t)$ . We will show how the dependence presents itself.

For  $x - ct < 0$ , we proceed as follows:

- Combine (3.3.2.4) with the general solution (3.3.2) at  $x = 0$

$$h(t) = F(-ct) + G(ct) \quad (3.3.2.6)$$

- Since  $x - ct < 0$  and since  $F$  is evaluated at this negative value, we use (3.3.2.6)

$$F(-ct) = h(t) - G(ct) \quad (3.3.2.7)$$

- Now let

$$z = -ct < 0$$

then

$$F(z) = h\left(-\frac{z}{c}\right) - G(-z). \quad (3.3.2.8)$$

So  $F$  for negative values is computed by (3.3.2.8) which requires  $G$  at positive values. In particular, we can take  $x - ct$  as  $z$ , to get

$$F(x - ct) = h\left(-\frac{x - ct}{c}\right) - G(ct - x). \quad (3.3.2.9)$$

- Now combine (3.3.2.9) with the formula (3.3.1.7) for  $G$

$$F(x - ct) = h\left(t - \frac{x}{c}\right) - \left(\frac{1}{2}f(ct - x) + \frac{1}{2c} \int_0^{ct-x} g(\xi) d\xi\right)$$

- The solution in sector II is then

$$u(x, t) = h\left(t - \frac{x}{c}\right) - \frac{1}{2}f(ct - x) - \frac{1}{2c} \int_0^{ct-x} g(\xi) d\xi + \frac{1}{2}f(x + ct) + \frac{1}{2c} \int_0^{x+ct} g(\xi) d\xi$$

$$u(x, t) = \begin{cases} \frac{f(x + ct) + f(x - ct)}{2} + \frac{1}{2c} \int_{x-ct}^{x+ct} g(\xi) d\xi & x - ct \geq 0 \\ h\left(t - \frac{x}{c}\right) + \frac{f(x + ct) - f(ct - x)}{2} + \frac{1}{2c} \int_{ct-x}^{x+ct} g(\xi) d\xi & x - ct < 0 \end{cases} \quad (3.3.2.10)$$

Note that the solution in sector II requires the knowledge of  $f(x)$  at point B (see Figure 23) which is the image of A about the  $t$  axis. The line BD is a characteristic (parallel to PC)

$$x + ct = K.$$

Therefore the solution at  $(x_1, t_1)$  is a combination of a wave moving on the characteristic CP and one moving on BD and reflected by the wall at  $x = 0$  to arrive at P along a characteristic

$$x - ct = x_1 - ct_1.$$



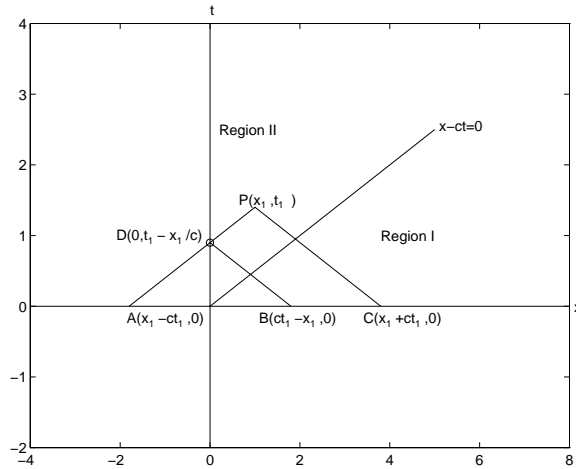

Figure 23: The solution at P

We now introduce several definitions to help us show that d'Alembert's solution (3.3.1.8) holds in other cases.

Definition 8. A function  $f(x)$  is called an even function if

$$f(-x) = f(x).$$

Definition 9. A function  $f(x)$  is called an odd function if

$$f(-x) = -f(x).$$

Note that some functions are neither.

Examples

1.  $f(x) = x^2$  is an even function.
2.  $f(x) = x^3$  is an odd function.
3.  $f(x) = x - x^2$  is neither odd nor even.

Definition 10. A function  $f(x)$  is called a periodic function of period  $p$  if

$$f(x + p) = f(x) \quad \text{for all } x.$$

The smallest such real number  $p$  is called the fundamental period.

Remark: If the boundary condition (3.3.2.4) is

$$u(0, t) = 0,$$

then the solution for the semi-infinite interval is the same as that for the infinite interval with  $f(x)$  and  $g(x)$  being extended as odd functions for  $x < 0$ . Since if  $f$  and  $g$  are odd functions then

$$\begin{aligned} f(-z) &= -f(z), \\ g(-z) &= -g(z). \end{aligned} \tag{3.3.2.11}$$

The solution for  $x - ct$  is now

$$u(x, t) = \frac{f(x + ct) - f(-(x - ct))}{2} + \frac{1}{2c} \left( \int_{ct-x}^0 g(\xi) d\xi + \int_0^{x+ct} g(\xi) d\xi \right). \quad (3.3.2.12)$$

But if we let  $\zeta = -\xi$  then

$$\begin{aligned} \int_{ct-x}^0 g(\xi) d\xi &= \int_{x-ct}^0 g(-\zeta)(-d\zeta) \\ &= \int_{x-ct}^0 -g(\zeta)(-d\zeta) = \int_{x-ct}^0 g(\zeta) d\zeta. \end{aligned}$$

Now combine this integral with the last term in (3.3.2.12) to have

$$u(x, t) = \frac{f(x + ct) + f(x - ct)}{2} + \frac{1}{2c} \int_{x-ct}^{x+ct} g(\xi) d\xi$$

which is exactly the same formula as for  $x - ct \geq 0$ . Therefore we have shown that for a semi-infinite string with fixed ends, one can use d'Alembert's solution (3.3.1.8) after extending  $f(x)$  and  $g(x)$  as odd functions for  $x < 0$ .

What happens if the boundary condition is

$$u_x(0, t) = 0?$$

We claim that one has to extend  $f(x)$ ,  $g(x)$  as even functions and then use (3.3.1.8). The details will be given in the next section.

### 3.3.3 Semi Infinite String with a Free End

In this section we show how to solve the wave equation

$$u_{tt} - c^2 u_{xx} = 0, \quad 0 \leq x < \infty, \quad (3.3.3.1)$$

subject to

$$u(x, 0) = f(x), \quad (3.3.3.2)$$

$$u_t(x, 0) = g(x), \quad (3.3.3.3)$$

$$u_x(0, t) = 0. \quad (3.3.3.4)$$

Clearly, the general solution for  $x - ct \geq 0$  is the same as before, i.e. given by (3.3.1.8). For  $x - ct < 0$ , we proceed in a similar fashion as last section. Using the boundary condition (3.3.3.4)

$$0 = u_x(0, t) = \left. \frac{dF(x - ct)}{dx} \right|_{x=0} + \left. \frac{dG(x + ct)}{dx} \right|_{x=0} = F'(-ct) + G'(ct).$$

Therefore

$$F'(-ct) = -G'(ct). \quad (3.3.3.5)$$

Let  $z = -ct < 0$  and integrate over  $[0, z]$

$$F(z) - F(0) = G(-z) - G(0). \quad (3.3.3.6)$$

From (3.3.1.6)-(3.3.1.7) we have

$$F(0) = G(0) = \frac{1}{2}f(0). \quad (3.3.3.7)$$

Replacing  $z$  by  $x - ct < 0$ , we have

$$F(x - ct) = G(-(x - ct)),$$

or

$$F(x - ct) = \frac{1}{2}f(ct - x) + \frac{1}{2c} \int_0^{ct-x} g(\xi) d\xi. \quad (3.3.3.8)$$

To summarize, the solution is

$$u(x, t) = \begin{cases} \frac{f(x + ct) + f(x - ct)}{2} + \frac{1}{2c} \int_{x-ct}^{x+ct} g(\xi) d\xi, & x \geq ct \\ \frac{f(x + ct) + f(ct - x)}{2} + \frac{1}{2c} \int_0^{x+ct} g(\xi) d\xi + \frac{1}{2c} \int_0^{ct-x} g(\xi) d\xi, & x < ct. \end{cases} \quad (3.3.3.9)$$

Remark: If  $f(x)$  and  $g(x)$  are extended for  $x < 0$  as even functions then

$$f(ct - x) = f(-(x - ct)) = f(x - ct)$$

and

$$\int_0^{ct-x} g(\xi) d\xi = \int_0^{x-ct} g(\zeta) (-d\zeta) = \int_{x-ct}^0 g(\zeta) d\zeta$$

where  $\zeta = -\xi$ .

Thus the integrals can be combined to one to give

$$\frac{1}{2c} \int_{x-ct}^{x+ct} g(\xi) d\xi.$$

Therefore with this extension of  $f(x)$  and  $g(x)$  we can write the solution in the form (3.3.1.8).

## Problems

1. Solve by the method of characteristics

$$\frac{\partial^2 u}{\partial t^2} - c^2 \frac{\partial^2 u}{\partial x^2} = 0, \quad x > 0$$

subject to

$$\begin{aligned} u(x, 0) &= 0, \\ \frac{\partial u}{\partial t}(x, 0) &= 0, \\ u(0, t) &= h(t). \end{aligned}$$

2. Solve

$$\frac{\partial^2 u}{\partial t^2} - c^2 \frac{\partial^2 u}{\partial x^2} = 0, \quad x < 0$$

subject to

$$\begin{aligned} u(x, 0) &= \sin x, & x < 0 \\ \frac{\partial u}{\partial t}(x, 0) &= 0, & x < 0 \\ u(0, t) &= e^{-t}, & t > 0. \end{aligned}$$

3. a. Solve

$$\frac{\partial^2 u}{\partial t^2} - c^2 \frac{\partial^2 u}{\partial x^2} = 0, \quad 0 < x < \infty$$

subject to

$$\begin{aligned} u(x, 0) &= \begin{cases} 0 & 0 < x < 2 \\ 1 & 2 < x < 3 \\ 0 & 3 < x \end{cases} \\ \frac{\partial u}{\partial t}(x, 0) &= 0, \\ \frac{\partial u}{\partial x}(0, t) &= 0. \end{aligned}$$

b. Suppose  $u$  is continuous at  $x = t = 0$ , sketch the solution at various times.

4. Solve

$$\frac{\partial^2 u}{\partial t^2} - c^2 \frac{\partial^2 u}{\partial x^2} = 0, \quad x > 0, \quad t > 0$$

subject to

$$\begin{aligned} u(x, 0) &= 0, \\ \frac{\partial u}{\partial t}(x, 0) &= 0, \\ \frac{\partial u}{\partial x}(0, t) &= h(t). \end{aligned}$$

5. Give the domain of influence in the case of semi-infinite string.

### 3.3.4 Finite String

This problem is more complicated because of multiple reflections. Consider the vibrations of a string of length  $L$ ,

$$u_{tt} - c^2 u_{xx} = 0, \quad 0 \leq x \leq L, \quad (3.3.4.1)$$

subject to

$$u(x, 0) = f(x), \quad (3.3.4.2)$$

$$u_t(x, 0) = g(x), \quad (3.3.4.3)$$

$$u(0, t) = 0, \quad (3.3.4.4)$$

$$u(L, t) = 0. \quad (3.3.4.5)$$

From the previous section, we can write the solution in regions 1 and 2 (see figure 24), i.e.

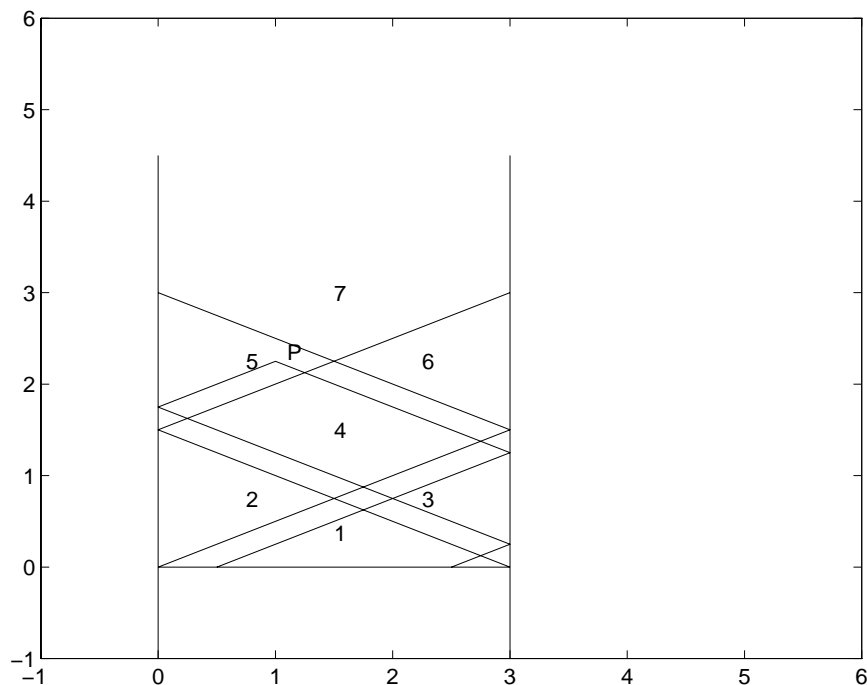

Figure 24: Reflected waves reaching a point in region 5

$u(x, t)$  is given by (3.3.1.8) in region 1 and by (3.3.2.10) with  $h \equiv 0$  in region 2. The solution in region 3 can be obtained in a similar fashion as (3.3.2.10), but now use the boundary condition (3.3.4.5).

In region 3, the boundary condition (3.3.4.5) becomes

$$u(L, t) = F(L - ct) + G(L + ct) = 0. \quad (3.3.4.6)$$

Since  $L + ct \geq L$ , we solve for  $G$

$$G(L + ct) = -F(L - ct).$$

Let

$$z = L + ct \geq L, \tag{3.3.4.7}$$

then

$$L - ct = 2L - z \leq L.$$

Thus

$$G(z) = -F(2L - z) \tag{3.3.4.8}$$

or

$$G(x + ct) = -F(2L - x - ct) = -\frac{1}{2}f(2L - x - ct) + \frac{1}{2c} \int_0^{2L-x-ct} g(\xi)d\xi$$

and so adding  $F(x - ct)$  given by (3.3.1.6) to the above we get the solution in region 3,

$$u(x, t) = \frac{f(x - ct) - f(2L - x - ct)}{2} + \frac{1}{2c} \int_0^{x-ct} g(\xi)d\xi + \frac{1}{2c} \int_0^{2L-x-ct} g(\xi)d\xi.$$

In other regions multiply reflected waves give the solution. (See figure 24, showing doubly reflected waves reaching points in region 5.)

As we remarked earlier, the boundary condition (3.3.4.4) essentially say that the initial conditions were extended as odd functions for  $x < 0$  (in this case for  $-L \leq x \leq 0$ .) The other boundary condition means that the initial conditions are extended again as odd functions to the interval  $[L, 2L]$ , which is the same as saying that the initial conditions on the interval  $[-L, L]$  are now extended periodically everywhere. Once the functions are extended to the real line, one can use (3.3.1.8) as a solution. A word of caution, this is true only when the boundary conditions are given by (3.3.4.4)-(3.3.4.5).

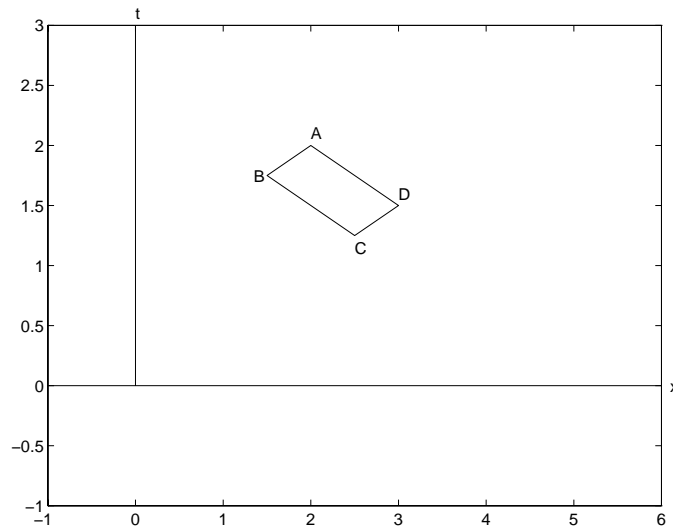

Figure 25: Parallelogram rule

### 3.3.5 Parallelogram Rule

If the four points  $A, B, C,$  and  $D$  form the vertices of a parallelogram whose sides are all segments of characteristic curves, (see figure 25) then the sums of the values of  $u$  at opposite vertices are equal, i.e.

$$u(A) + u(C) = u(B) + u(D). \quad (3.3.5.1)$$

This rule is useful in solving a problem with both initial and boundary conditions.

In region  $R_1$  (see figure 26) the solution is defined by d'Alembert's formula. For  $A = (x, t)$  in region  $R_2$ , let us form the parallelogram  $ABCD$  with  $B$  on the  $t$ -axis and  $C$  and  $D$  on the characteristic curve from  $(0, 0)$ . Thus

$$u(A) = -u(C) + u(B) + u(D) \quad (3.3.5.2)$$

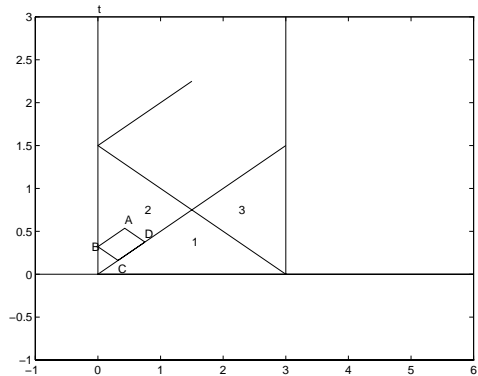

Figure 26: Use of parallelogram rule to solve the finite string case

$u(B)$  is a known boundary value and the others are known from  $R_1$ . We can do this for any point  $A$  in  $R_2$ . Similarly for  $R_3$ . One can use the solutions in  $R_2, R_3$  to get the solution in  $R_4$  and so on. The limitation is that  $u$  must be given on the boundary. If the boundary conditions are not of Dirichlet type, this rule is not helpful.

## SUMMARY

Linear:

$$u_t + c(x, t)u_x = S(u, x, t)$$
$$u(x(0), 0) = f(x(0))$$

Solve the characteristic equation

$$\frac{dx}{dt} = c(x, t)$$
$$x(0) = x_0$$

then solve

$$\frac{du}{dt} = S(u, x, t)$$
$$u(x(0), 0) = f(x(0)) \quad \text{on the characteristic curve}$$

Quasilinear:

$$u_t + c(u, x, t)u_x = S(u, x, t)$$
$$u(x(0), 0) = f(x(0))$$

Solve the characteristic equation

$$\frac{dx}{dt} = c(u, x, t)$$
$$x(0) = x_0$$

then solve

$$\frac{du}{dt} = S(u, x, t)$$
$$u(x(0), 0) = f(x(0)) \quad \text{on the characteristic curve}$$

fan-like characteristics

shock waves

Second order hyperbolic equations:

Infinite string

$$u_{tt} - c^2 u_{xx} = 0 \quad c = \text{constant}, \quad -\infty < x < \infty$$
$$u(x, 0) = f(x),$$
$$u_t(x, 0) = g(x),$$
$$u(x, t) = \frac{f(x+ct) + f(x-ct)}{2} + \frac{1}{2c} \int_{x-ct}^{x+ct} g(\xi) d\xi.$$



Semi infinite string

$$u_{tt} - c^2 u_{xx} = 0 \quad c = \text{constant}, \quad 0 \leq x < \infty$$

$$u(x, 0) = f(x),$$

$$u_t(x, 0) = g(x),$$

$$u(0, t) = h(t), \quad 0 \leq t.$$

$$u(x, t) = \begin{cases} \frac{f(x+ct) + f(x-ct)}{2} + \frac{1}{2c} \int_{x-ct}^{x+ct} g(\xi) d\xi, & x - ct \geq 0, \\ h\left(t - \frac{x}{c}\right) + \frac{f(x+ct) - f(ct-x)}{2} + \frac{1}{2c} \int_{ct-x}^{x+ct} g(\xi) d\xi, & x - ct < 0. \end{cases}$$

Semi infinite string - free end

$$u_{tt} - c^2 u_{xx} = 0 \quad c = \text{constant}, \quad 0 \leq x < \infty,$$

$$u(x, 0) = f(x),$$

$$u_t(x, 0) = g(x),$$

$$u_x(0, t) = h(t).$$

$$u(x, t) = \begin{cases} \frac{f(x+ct) + f(x-ct)}{2} + \frac{1}{2c} \int_{x-ct}^{x+ct} g(\xi) d\xi, & x \geq ct, \\ \int_0^{x-ct} h(-z/c) dz + \frac{f(x+ct) + f(ct-x)}{2} + \frac{1}{2c} \int_0^{x+ct} g(\xi) d\xi + \frac{1}{2c} \int_0^{ct-x} g(\xi) d\xi, & x < ct. \end{cases}$$

## 4 Separation of Variables-Homogeneous Equations

In this chapter we show that the process of separation of variables solves the one dimensional heat equation subject to various homogeneous boundary conditions and solves Laplace's equation. All problems in this chapter are homogeneous. We will not be able to give the solution without the knowledge of Fourier series. Therefore these problems will not be fully solved until Chapter 6 after we discuss Fourier series.

### 4.1 Parabolic equation in one dimension

In this section we show how separation of variables is applied to solve a simple problem of heat conduction in a bar whose ends are held at zero temperature.

$$u_t = ku_{xx}, \quad (4.1.1)$$

$$u(0, t) = 0, \quad \text{zero temperature on the left,} \quad (4.1.2)$$

$$u(L, t) = 0, \quad \text{zero temperature on the right,} \quad (4.1.3)$$

$$u(x, 0) = f(x), \quad \text{given initial distribution of temperature.} \quad (4.1.4)$$

Note that the equation must be linear and for the time being also homogeneous (no heat sources or sinks). The boundary conditions must also be linear and homogeneous. In Chapter 8 we will show how inhomogeneous boundary conditions can be transferred to a source/sink and then how to solve inhomogeneous partial differential equations. The method there requires the knowledge of eigenfunctions which are the solutions of the spatial parts of the homogeneous problems with homogeneous boundary conditions.

The idea of separation of variables is to assume a solution of the form

$$u(x, t) = X(x)T(t), \quad (4.1.5)$$

that is the solution can be written as a product of a function of  $x$  and a function of  $t$ . Differentiate (4.1.5) and substitute in (4.1.1) to obtain

$$X(x)\dot{T}(t) = kX''(x)T(t), \quad (4.1.6)$$

where prime denotes differentiation with respect to  $x$  and dot denotes time derivative. In order to separate the variables, we divide the equation by  $kX(x)T(t)$ ,

$$\frac{\dot{T}(t)}{kT(t)} = \frac{X''(x)}{X(x)}. \quad (4.1.7)$$

The left hand side depends only on  $t$  and the right hand side only on  $x$ . If we fix one variable, say  $t$ , and vary the other, then the left hand side cannot change ( $t$  is fixed) therefore the right hand side cannot change. This means that each side is really a constant. We denote that so called separation constant by  $-\lambda$ . Now we have two ordinary differential equations

$$X''(x) = -\lambda X(x), \quad (4.1.8)$$

$$\dot{T}(t) = -k\lambda T(t). \quad (4.1.9)$$

Remark: This does NOT mean that the separation constant is negative.

The homogeneous boundary conditions can be used to provide boundary conditions for (4.1.8). These are

$$X(0)T(t) = 0,$$

$$X(L)T(t) = 0.$$

Since  $T(t)$  cannot be zero (otherwise the solution  $u(x, t) = X(x)T(t)$  is zero), then

$$X(0) = 0, \quad (4.1.10)$$

$$X(L) = 0. \quad (4.1.11)$$

First we solve (4.1.8) subject to (4.1.10)-(4.1.11). This can be done by analyzing the following 3 cases. (We will see later that the separation constant  $\lambda$  is real.)

case 1:  $\lambda < 0$ .

The solution of (4.1.8) is

$$X(x) = Ae^{\sqrt{\mu}x} + Be^{-\sqrt{\mu}x}, \quad (4.1.12)$$

where  $\mu = -\lambda > 0$ .

Recall that one should try  $e^{rx}$  which leads to the characteristic equation  $r^2 = \mu$ . Using the boundary conditions, we have two equations for the parameters  $A, B$

$$A + B = 0, \quad (4.1.13)$$

$$Ae^{\sqrt{\mu}L} + Be^{-\sqrt{\mu}L} = 0. \quad (4.1.14)$$

Solve (4.1.13) for  $B$  and substitute in (4.1.14)

$$B = -A$$

$$A(e^{\sqrt{\mu}L} - e^{-\sqrt{\mu}L}) = 0.$$

Note that

$$e^{\sqrt{\mu}L} - e^{-\sqrt{\mu}L} = 2 \sinh \sqrt{\mu}L \neq 0$$

Therefore  $A = 0$  which implies  $B = 0$  and thus the solution is trivial (the zero solution).

Later we will see the use of writing the solution of (4.1.12) in one of the following four forms

$$\begin{aligned} X(x) &= Ae^{\sqrt{\mu}x} + Be^{-\sqrt{\mu}x} \\ &= C \cosh \sqrt{\mu}x + D \sinh \sqrt{\mu}x \\ &= E \cosh \left( \sqrt{\mu}x + F \right) \\ &= G \sinh \left( \sqrt{\mu}x + H \right). \end{aligned} \quad (4.1.15)$$

In figure 27 we have plotted the hyperbolic functions  $\sinh x$  and  $\cosh x$ , so one can see that the hyperbolic sine vanishes only at **one** point and the hyperbolic cosine never vanishes.

case 2:  $\lambda = 0$ .

cosh(x),sinh(x)

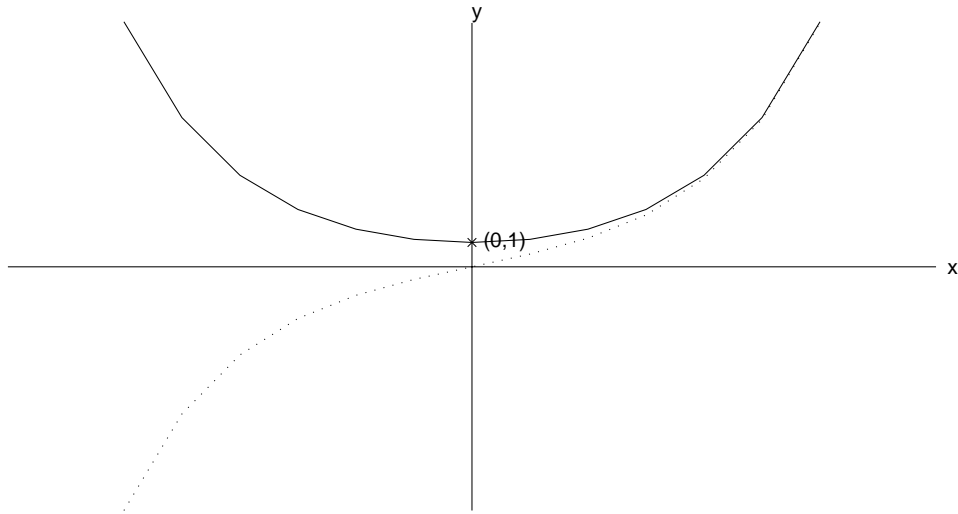

Figure 27:  $\sinh x$  and  $\cosh x$

This leads to

$$X''(x) = 0, \quad (4.1.16)$$

$$X(0) = 0,$$

$$X(L) = 0.$$

The ODE has a solution

$$X(x) = Ax + B. \quad (4.1.17)$$

Using the boundary conditions

$$A \cdot 0 + B = 0,$$

$$A \cdot L + B = 0,$$

we have

$$B = 0,$$

$$A = 0,$$

and thus

$$X(x) = 0,$$

which is the trivial solution (leads to  $u(x, t) = 0$ ) and thus of no interest.

case 3:  $\lambda > 0$ .

The solution in this case is

$$X(x) = A \cos \sqrt{\lambda}x + B \sin \sqrt{\lambda}x. \quad (4.1.18)$$

The first boundary condition leads to

$$X(0) = A \cdot 1 + B \cdot 0 = 0$$

which implies

$$A = 0.$$

Therefore, the second boundary condition (with  $A = 0$ ) becomes

$$B \sin \sqrt{\lambda}L = 0. \quad (4.1.19)$$

Clearly  $B \neq 0$  (otherwise the solution is trivial again), therefore

$$\sin \sqrt{\lambda}L = 0,$$

and thus

$$\sqrt{\lambda}L = n\pi, \quad n = 1, 2, \dots \quad (\text{since } \lambda > 0, \text{ then } n \geq 1)$$

and

$$\lambda_n = \left(\frac{n\pi}{L}\right)^2, \quad n = 1, 2, \dots \quad (4.1.20)$$

These are called the eigenvalues. The solution (4.1.18) becomes

$$X_n(x) = B_n \sin \frac{n\pi}{L}x, \quad n = 1, 2, \dots \quad (4.1.21)$$

The functions  $X_n$  are called eigenfunctions or modes. There is no need to carry the constants  $B_n$ , since the eigenfunctions are unique only to a multiplicative scalar (i.e. if  $X_n$  is an eigenfunction then  $KX_n$  is also an eigenfunction).

The eigenvalues  $\lambda_n$  will be substituted in (4.1.9) before it is solved, therefore

$$\dot{T}_n(t) = -k \left(\frac{n\pi}{L}\right)^2 T_n. \quad (4.1.22)$$

The solution is

$$T_n(t) = e^{-k\left(\frac{n\pi}{L}\right)^2 t}, \quad n = 1, 2, \dots \quad (4.1.23)$$

Combine (4.1.21) and (4.1.23) with (4.1.5)

$$u_n(x, t) = e^{-k\left(\frac{n\pi}{L}\right)^2 t} \sin \frac{n\pi}{L}x, \quad n = 1, 2, \dots \quad (4.1.24)$$

Since the PDE is linear, the linear combination of all the solutions  $u_n(x, t)$  is also a solution

$$u(x, t) = \sum_{n=1}^{\infty} b_n e^{-k\left(\frac{n\pi}{L}\right)^2 t} \sin \frac{n\pi}{L}x. \quad (4.1.25)$$

This is known as the principle of superposition. As in power series solution of ODEs, we have to prove that the infinite series converges (see section 5.5). This solution satisfies the PDE and the boundary conditions. To find  $b_n$ , we must use the initial condition and this will be done after we learn Fourier series.

## 4.2 Other Homogeneous Boundary Conditions

If one has to solve the heat equation subject to one of the following sets of boundary conditions

1.

$$u(0, t) = 0, \quad (4.2.1)$$

$$u_x(L, t) = 0. \quad (4.2.2)$$

2.

$$u_x(0, t) = 0, \quad (4.2.3)$$

$$u(L, t) = 0. \quad (4.2.4)$$

3.

$$u_x(0, t) = 0, \quad (4.2.5)$$

$$u_x(L, t) = 0. \quad (4.2.6)$$

4.

$$u(0, t) = u(L, t), \quad (4.2.7)$$

$$u_x(0, t) = u_x(L, t). \quad (4.2.8)$$

the procedure will be similar. In fact, (4.1.8) and (4.1.9) are unaffected. In the first case, (4.2.1)-(4.2.2) will be

$$X(0) = 0, \quad (4.2.9)$$

$$X'(L) = 0. \quad (4.2.10)$$

It is left as an exercise to show that

$$\lambda_n = \left[ \left( n - \frac{1}{2} \right) \frac{\pi}{L} \right]^2, \quad n = 1, 2, \dots \quad (4.2.11)$$

$$X_n = \sin \left( n - \frac{1}{2} \right) \frac{\pi}{L} x, \quad n = 1, 2, \dots \quad (4.2.12)$$

The boundary conditions (4.2.3)-(4.2.4) lead to

$$X'(0) = 0, \quad (4.2.13)$$

$$X(L) = 0, \quad (4.2.14)$$

and the eigenpairs are

$$\lambda_n = \left[ \left( n - \frac{1}{2} \right) \frac{\pi}{L} \right]^2, \quad n = 1, 2, \dots \quad (4.2.15)$$

$$X_n = \cos \left( n - \frac{1}{2} \right) \frac{\pi}{L} x, \quad n = 1, 2, \dots \quad (4.2.16)$$

The third case leads to

$$X'(0) = 0, \quad (4.2.17)$$

$$X'(L) = 0. \quad (4.2.18)$$

Here the eigenpairs are

$$\lambda_0 = 0, \quad (4.2.19)$$

$$X_0 = 1, \quad (4.2.20)$$

$$\lambda_n = \left(\frac{n\pi}{L}\right)^2, \quad n = 1, 2, \dots \quad (4.2.21)$$

$$X_n = \cos \frac{n\pi}{L}x, \quad n = 1, 2, \dots \quad (4.2.22)$$

The case of periodic boundary conditions require detailed solution.

case 1:  $\lambda < 0$ .

The solution is given by (4.1.12)

$$X(x) = Ae^{\sqrt{\mu}x} + Be^{-\sqrt{\mu}x}, \quad \mu = -\lambda > 0.$$

The boundary conditions (4.2.7)-(4.2.8) imply

$$A + B = Ae^{\sqrt{\mu}L} + Be^{-\sqrt{\mu}L}, \quad (4.2.23)$$

$$A\sqrt{\mu} - B\sqrt{\mu} = A\sqrt{\mu}e^{\sqrt{\mu}L} - B\sqrt{\mu}e^{-\sqrt{\mu}L}. \quad (4.2.24)$$

This system can be written as

$$A(1 - e^{\sqrt{\mu}L}) + B(1 - e^{-\sqrt{\mu}L}) = 0, \quad (4.2.25)$$

$$\sqrt{\mu}A(1 - e^{\sqrt{\mu}L}) + \sqrt{\mu}B(-1 + e^{-\sqrt{\mu}L}) = 0. \quad (4.2.26)$$

This homogeneous system can have a solution only if the determinant of the coefficient matrix is zero, i.e.

$$\begin{vmatrix} 1 - e^{\sqrt{\mu}L} & 1 - e^{-\sqrt{\mu}L} \\ (1 - e^{\sqrt{\mu}L})\sqrt{\mu} & (-1 + e^{-\sqrt{\mu}L})\sqrt{\mu} \end{vmatrix} = 0.$$

Evaluating the determinant, we get

$$2\sqrt{\mu}(e^{\sqrt{\mu}L} + e^{-\sqrt{\mu}L} - 2) = 0,$$

which is not possible for  $\mu > 0$ .

case 2:  $\lambda = 0$ .

The solution is given by (4.1.17). To use the boundary conditions, we have to differentiate  $X(x)$ ,

$$X'(x) = A. \quad (4.2.27)$$

The conditions (4.2.8) and (4.2.7) correspondingly imply

$$A = A,$$

$$B = AL + B, \quad \Rightarrow AL = 0 \quad \Rightarrow A = 0.$$

Thus for the eigenvalue

$$\lambda_0 = 0, \quad (4.2.28)$$

the eigenfunction is

$$X_0(x) = 1. \quad (4.2.29)$$

case 3:  $\lambda > 0$ .

The solution is given by

$$X(x) = A \cos \sqrt{\lambda}x + B \sin \sqrt{\lambda}x. \quad (4.2.30)$$

The boundary conditions give the following equations for  $A, B$ ,

$$A = A \cos \sqrt{\lambda}L + B \sin \sqrt{\lambda}L,$$

$$\sqrt{\lambda}B = -\sqrt{\lambda}A \sin \sqrt{\lambda}L + \sqrt{\lambda}B \cos \sqrt{\lambda}L,$$

or

$$A(1 - \cos \sqrt{\lambda}L) - B \sin \sqrt{\lambda}L = 0, \quad (4.2.31)$$

$$A\sqrt{\lambda} \sin \sqrt{\lambda}L + B\sqrt{\lambda}(1 - \cos \sqrt{\lambda}L) = 0. \quad (4.2.32)$$

The determinant of the coefficient matrix

$$\begin{vmatrix} 1 - \cos \sqrt{\lambda}L & -\sin \sqrt{\lambda}L \\ \sqrt{\lambda} \sin \sqrt{\lambda}L & \sqrt{\lambda}(1 - \cos \sqrt{\lambda}L) \end{vmatrix} = 0,$$

or

$$\sqrt{\lambda}(1 - \cos \sqrt{\lambda}L)^2 + \sqrt{\lambda} \sin^2 \sqrt{\lambda}L = 0.$$

Expanding and using some trigonometric identities,

$$2\sqrt{\lambda}(1 - \cos \sqrt{\lambda}L) = 0,$$

or

$$1 - \cos \sqrt{\lambda}L = 0. \quad (4.2.33)$$

Thus (4.2.31)-(4.2.32) become

$$-B \sin \sqrt{\lambda}L = 0,$$

$$A\sqrt{\lambda} \sin \sqrt{\lambda}L = 0,$$

which imply

$$\sin \sqrt{\lambda}L = 0. \quad (4.2.34)$$

Thus the eigenvalues  $\lambda_n$  must satisfy (4.2.33) and (4.2.34), that is

$$\lambda_n = \left(\frac{2n\pi}{L}\right)^2, \quad n = 1, 2, \dots \quad (4.2.35)$$



Condition (4.2.34) causes the system to be true for any  $A, B$ , therefore the eigenfunctions are

$$X_n(x) = \begin{cases} \cos \frac{2n\pi}{L}x & n = 1, 2, \dots \\ \sin \frac{2n\pi}{L}x & n = 1, 2, \dots \end{cases} \quad (4.2.36)$$

In summary, for periodic boundary conditions

$$\lambda_0 = 0, \quad (4.2.37)$$

$$X_0(x) = 1, \quad (4.2.38)$$

$$\lambda_n = \left(\frac{2n\pi}{L}\right)^2, \quad n = 1, 2, \dots \quad (4.2.39)$$

$$X_n(x) = \begin{cases} \cos \frac{2n\pi}{L}x & n = 1, 2, \dots \\ \sin \frac{2n\pi}{L}x & n = 1, 2, \dots \end{cases} \quad (4.2.40)$$

Remark: The ODE for  $X$  is the same even when we separate the variables for the wave equation. For Laplace's equation, we treat either the  $x$  or the  $y$  as the marching variable (depending on the boundary conditions given).

Example.

$$u_{xx} + u_{yy} = 0 \quad 0 \leq x, y \leq 1 \quad (4.2.41)$$

$$u(x, 0) = u_0 = \text{constant} \quad (4.2.42)$$

$$u(x, 1) = 0 \quad (4.2.43)$$

$$u(0, y) = u(1, y) = 0. \quad (4.2.44)$$

This leads to

$$X'' + \lambda X = 0 \quad (4.2.45)$$

$$X(0) = X(1) = 0 \quad (4.2.46)$$

and

$$Y'' - \lambda Y = 0 \quad (4.2.47)$$

$$Y(1) = 0. \quad (4.2.48)$$

The eigenvalues and eigenfunctions are

$$X_n = \sin n\pi x, \quad n = 1, 2, \dots \quad (4.2.49)$$

$$\lambda_n = (n\pi)^2, \quad n = 1, 2, \dots \quad (4.2.50)$$

The solution for the  $y$  equation is then

$$Y_n = \sinh n\pi(y - 1) \quad (4.2.51)$$

and the solution of the problem is

$$u(x, y) = \sum_{n=1}^{\infty} \alpha_n \sin n\pi x \sinh n\pi(y - 1) \quad (4.2.52)$$

and the parameters  $\alpha_n$  can be obtained from the Fourier expansion of the nonzero boundary condition, i.e.

$$\alpha_n = \frac{2u_0}{n\pi} \frac{(-1)^n - 1}{\sinh n\pi}. \quad (4.2.53)$$

## Problems

1. Consider the differential equation

$$X''(x) + \lambda X(x) = 0$$

Determine the eigenvalues  $\lambda$  (assumed real) subject to

- a.  $X(0) = X(\pi) = 0$
- b.  $X'(0) = X'(L) = 0$
- c.  $X(0) = X'(L) = 0$
- d.  $X'(0) = X(L) = 0$
- e.  $X(0) = 0$  and  $X'(L) + X(L) = 0$

Analyze the cases  $\lambda > 0$ ,  $\lambda = 0$  and  $\lambda < 0$ .

### 4.3 Eigenvalues and Eigenfunctions

As we have seen in the previous sections, the solution of the  $X$ -equation on a finite interval subject to homogeneous boundary conditions, results in a sequence of eigenvalues and corresponding eigenfunctions. Eigenfunctions are said to describe natural vibrations and standing waves.  $X_1$  is the fundamental and  $X_i$ ,  $i > 1$  are the harmonics. The eigenvalues are the natural frequencies of vibration. These frequencies do not depend on the initial conditions. This means that the frequencies of the natural vibrations are independent of the method to excite them. They characterize the properties of the vibrating system itself and are determined by the material constants of the system, geometrical factors and the conditions on the boundary.

The eigenfunction  $X_n$  specifies the profile of the standing wave. The points at which an eigenfunction vanishes are called “nodal points” (nodal lines in two dimensions). The nodal lines are the curves along which the membrane at rest during eigenvibration. For a square membrane of side  $\pi$  the eigenfunction (as can be found in Chapter 4) are  $\sin nx \sin my$  and the nodal lines are lines parallel to the coordinate axes. However, in the case of multiple eigenvalues, many other nodal lines occur.

Some boundary conditions may not be exclusive enough to result in a unique solution (up to a multiplicative constant) for each eigenvalue. In case of a double eigenvalue, any pair of independent solutions can be used to express the most general eigenfunction for this eigenvalue. Usually, it is best to choose the two solutions so they are orthogonal to each other. This is necessary for the completeness property of the eigenfunctions. This can be done by adding certain symmetry requirement over and above the boundary conditions, which pick either one or the other. For example, in the case of periodic boundary conditions, each positive eigenvalue has two eigenfunctions, one is even and the other is odd. Thus the symmetry allows us to choose. If symmetry is not imposed then both functions must be taken.

The eigenfunctions, as we proved in Chapter 6 of Neta, form a complete set which is the basis for the method of eigenfunction expansion described in Chapter 5 for the solution of inhomogeneous problems (inhomogeneity in the equation or the boundary conditions).

## SUMMARY

$$X'' + \lambda X = 0$$

Boundary conditions	Eigenvalues $\lambda_n$	Eigenfunctions $X_n$
$X(0) = X(L) = 0$	$\left(\frac{n\pi}{L}\right)^2$	$\sin \frac{n\pi}{L}x \quad n = 1, 2, \dots$
$X(0) = X'(L) = 0$	$\left[\frac{(n-\frac{1}{2})\pi}{L}\right]^2$	$\sin \frac{(n-\frac{1}{2})\pi}{L}x \quad n = 1, 2, \dots$
$X'(0) = X(L) = 0$	$\left[\frac{(n-\frac{1}{2})\pi}{L}\right]^2$	$\cos \frac{(n-\frac{1}{2})\pi}{L}x \quad n = 1, 2, \dots$
$X'(0) = X'(L) = 0$	$\left(\frac{n\pi}{L}\right)^2$	$\cos \frac{n\pi}{L}x \quad n = 0, 1, 2, \dots$
$X(0) = X(L), X'(0) = X'(L)$	$\left(\frac{2n\pi}{L}\right)^2$	$\sin \frac{2n\pi}{L}x \quad n = 1, 2, \dots$
		$\cos \frac{2n\pi}{L}x \quad n = 0, 1, 2, \dots$

## 5 Fourier Series

In this chapter we discuss Fourier series and the application to the solution of PDEs by the method of separation of variables. In the last section, we return to the solution of the problems in Chapter 4 and also show how to solve Laplace's equation. We discuss the eigenvalues and eigenfunctions of the Laplacian. The application of these eigenpairs to the solution of the heat and wave equations in bounded domains will follow in Chapter 7 (for higher dimensions and a variety of coordinate systems) and Chapter 8 (for nonhomogeneous problems.)

### 5.1 Introduction

As we have seen in the previous chapter, the method of separation of variables requires the ability of presenting the initial condition in a Fourier series. Later we will find that generalized Fourier series are necessary. In this chapter we will discuss the Fourier series expansion of  $f(x)$ , i.e.

$$f(x) \sim \frac{a_0}{2} + \sum_{n=1}^{\infty} \left( a_n \cos \frac{n\pi}{L}x + b_n \sin \frac{n\pi}{L}x \right). \quad (5.1.1)$$

We will discuss how the coefficients are computed, the conditions for convergence of the series, and the conditions under which the series can be differentiated or integrated term by term.

**Definition 11.** A function  $f(x)$  is piecewise continuous in  $[a, b]$  if there exists a finite number of points  $a = x_1 < x_2 < \dots < x_n = b$ , such that  $f$  is continuous in each open interval  $(x_j, x_{j+1})$  and the one sided limits  $f(x_{j+})$  and  $f(x_{j+1-})$  exist for all  $j \leq n - 1$ .

#### Examples

1.  $f(x) = x^2$  is continuous on  $[a, b]$ .

2.

$$f(x) = \begin{cases} x & 0 \leq x < 1 \\ x^2 - x & 1 < x \leq 2 \end{cases}$$

The function is piecewise continuous but not continuous because of the point  $x = 1$ .

3.  $f(x) = \frac{1}{x}$   $-1 \leq x \leq 1$ . The function is not piecewise continuous because the one sided limit at  $x = 0$  does not exist.

**Definition 12.** A function  $f(x)$  is piecewise smooth if  $f(x)$  and  $f'(x)$  are piecewise continuous.

**Definition 13.** A function  $f(x)$  is periodic if  $f(x)$  is piecewise continuous and  $f(x+p) = f(x)$  for some real positive number  $p$  and all  $x$ . The number  $p$  is called a period. The smallest period is called the fundamental period.

#### Examples

1.  $f(x) = \sin x$  is periodic of period  $2\pi$ .

2.  $f(x) = \cos x$  is periodic of period  $2\pi$ .

Note: If  $f_i(x)$ ,  $i = 1, 2, \dots, n$  are all periodic of the same period  $p$  then the linear combination of these functions

$$\sum_{i=1}^n c_i f_i(x)$$

is also periodic of period  $p$ .

## 5.2 Orthogonality

Recall that two vectors  $\vec{a}$  and  $\vec{b}$  in  $\mathcal{R}^n$  are called orthogonal vectors if

$$\vec{a} \cdot \vec{b} = \sum_{i=1}^n a_i b_i = 0.$$

We would like to extend this definition to functions. Let  $f(x)$  and  $g(x)$  be two functions defined on the interval  $[\alpha, \beta]$ . If we sample the two functions at the same points  $x_i$ ,  $i = 1, 2, \dots, n$  then the vectors  $\vec{F}$  and  $\vec{G}$ , having components  $f(x_i)$  and  $g(x_i)$  correspondingly, are orthogonal if

$$\sum_{i=1}^n f(x_i)g(x_i) = 0.$$

If we let  $n$  to increase to infinity then we get an infinite sum which is proportional to

$$\int_{\alpha}^{\beta} f(x)g(x)dx.$$

Therefore, we define orthogonality as follows:

**Definition 14.** Two functions  $f(x)$  and  $g(x)$  are called orthogonal on the interval  $(\alpha, \beta)$  with respect to the weight function  $w(x) > 0$  if

$$\int_{\alpha}^{\beta} w(x)f(x)g(x)dx = 0.$$

### Example 1

The functions  $\sin x$  and  $\cos x$  are orthogonal on  $[-\pi, \pi]$  with respect to  $w(x) = 1$ ,

$$\int_{-\pi}^{\pi} \sin x \cos x dx = \frac{1}{2} \int_{-\pi}^{\pi} \sin 2x dx = -\frac{1}{4} \cos 2x \Big|_{-\pi}^{\pi} = -\frac{1}{4} + \frac{1}{4} = 0.$$

**Definition 15.** A set of functions  $\{\phi_n(x)\}$  is called orthogonal system with respect to  $w(x)$  on  $[\alpha, \beta]$  if

$$\int_{\alpha}^{\beta} \phi_n(x)\phi_m(x)w(x)dx = 0, \quad \text{for } m \neq n. \quad (5.2.1)$$

Definition 16. The norm of a function  $f(x)$  with respect to  $w(x)$  on the interval  $[\alpha, \beta]$  is defined by

$$\|f\| = \left\{ \int_{\alpha}^{\beta} w(x) f^2(x) dx \right\}^{1/2} \quad (5.2.2)$$

Definition 17. The set  $\{\phi_n(x)\}$  is called orthonormal system if it is an orthogonal system and if

$$\|\phi_n\| = 1. \quad (5.2.3)$$

### Examples

1.  $\left\{ \sin \frac{n\pi}{L} x \right\}$  is an orthogonal system with respect to  $w(x) = 1$  on  $[-L, L]$ .  
For  $n \neq m$

$$\begin{aligned} & \int_{-L}^L \sin \frac{n\pi}{L} x \sin \frac{m\pi}{L} x dx \\ &= \int_{-L}^L \left[ -\frac{1}{2} \cos \frac{(n+m)\pi}{L} x + \frac{1}{2} \cos \frac{(n-m)\pi}{L} x \right] dx \\ &= \left\{ -\frac{1}{2} \frac{L}{(n+m)\pi} \sin \frac{(n+m)\pi}{L} x + \frac{1}{2} \frac{L}{(n-m)\pi} \sin \frac{(n-m)\pi}{L} x \right\} \Big|_{-L}^L = 0 \end{aligned}$$

2.  $\left\{ \cos \frac{n\pi}{L} x \right\}$  is also an orthogonal system on the same interval. It is easy to show that for  $n \neq m$

$$\begin{aligned} & \int_{-L}^L \cos \frac{n\pi}{L} x \cos \frac{m\pi}{L} x dx \\ &= \int_{-L}^L \left[ \frac{1}{2} \cos \frac{(n+m)\pi}{L} x + \frac{1}{2} \cos \frac{(n-m)\pi}{L} x \right] dx \\ &= \left\{ \frac{1}{2} \frac{L}{(n+m)\pi} \sin \frac{(n+m)\pi}{L} x + \frac{1}{2} \frac{L}{(n-m)\pi} \sin \frac{(n-m)\pi}{L} x \right\} \Big|_{-L}^L = 0 \end{aligned}$$

3. The set  $\{1, \cos x, \sin x, \cos 2x, \sin 2x, \dots, \cos nx, \sin nx, \dots\}$  is an orthogonal system on  $[-\pi, \pi]$  with respect to the weight function  $w(x) = 1$ .

We have shown already that

$$\int_{-\pi}^{\pi} \sin nx \sin mx dx = 0 \quad \text{for } n \neq m \quad (5.2.4)$$

$$\int_{-\pi}^{\pi} \cos nx \cos mx dx = 0 \quad \text{for } n \neq m. \quad (5.2.5)$$



The only thing left to show is therefore

$$\int_{-\pi}^{\pi} 1 \cdot \sin nx dx = 0 \quad (5.2.6)$$

$$\int_{-\pi}^{\pi} 1 \cdot \cos nx dx = 0 \quad (5.2.7)$$

and

$$\int_{-\pi}^{\pi} \sin nx \cos mx dx = 0 \quad \text{for any } n, m. \quad (5.2.8)$$

Note that

$$\int_{-\pi}^{\pi} \sin nx dx = -\frac{\cos nx}{n} \Big|_{-\pi}^{\pi} = -\frac{1}{n} (\cos n\pi - \cos(-n\pi)) = 0$$

since

$$\cos n\pi = \cos(-n\pi) = (-1)^n. \quad (5.2.9)$$

In a similar fashion we demonstrate (5.2.7). This time the antiderivative  $\frac{1}{n} \sin nx$  vanishes at both ends.

To show (5.2.8) we consider first the case  $n = m$ . Thus

$$\int_{-\pi}^{\pi} \sin nx \cos nx dx = \frac{1}{2} \int_{-\pi}^{\pi} \sin 2nx dx = -\frac{1}{4n} \cos 2nx \Big|_{-\pi}^{\pi} = 0$$

For  $n \neq m$ , we can use the trigonometric identity

$$\sin ax \cos bx = \frac{1}{2} [\sin(a+b)x + \sin(a-b)x]. \quad (5.2.10)$$

Integrating each of these terms gives zero as in (5.2.6). Therefore the system is orthogonal.

### 5.3 Computation of Coefficients

Suppose that  $f(x)$  can be expanded in Fourier series

$$f(x) \sim \frac{a_0}{2} + \sum_{k=1}^{\infty} \left( a_k \cos \frac{k\pi}{L}x + b_k \sin \frac{k\pi}{L}x \right). \quad (5.3.1)$$

The infinite series may or may not converge. Even if the series converges, it may not give the value of  $f(x)$  at some points. The question of convergence will be left for later. In this section we just give the formulae used to compute the coefficients  $a_k, b_k$ .

$$a_0 = \frac{1}{L} \int_{-L}^L f(x) dx, \quad (5.3.2)$$

$$a_k = \frac{1}{L} \int_{-L}^L f(x) \cos \frac{k\pi}{L}x dx \quad \text{for } k = 1, 2, \dots \quad (5.3.3)$$

$$b_k = \frac{1}{L} \int_{-L}^L f(x) \sin \frac{k\pi}{L} x dx \quad \text{for } k = 1, 2, \dots \quad (5.3.4)$$

Notice that for  $k = 0$  (5.3.3) gives the same value as  $a_0$  in (5.3.2). This is the case only if one takes  $\frac{a_0}{2}$  as the first term in (5.3.1), otherwise the constant term is

$$\frac{1}{2L} \int_{-L}^L f(x) dx. \quad (5.3.5)$$

The factor  $L$  in (5.3.3)-(5.3.4) is exactly the square of the norm of the functions  $\sin \frac{k\pi}{L} x$  and  $\cos \frac{k\pi}{L} x$ . In general, one should write the coefficients as follows:

$$a_k = \frac{\int_{-L}^L f(x) \cos \frac{k\pi}{L} x dx}{\int_{-L}^L \cos^2 \frac{k\pi}{L} x dx}, \quad \text{for } k = 1, 2, \dots \quad (5.3.6)$$

$$b_k = \frac{\int_{-L}^L f(x) \sin \frac{k\pi}{L} x dx}{\int_{-L}^L \sin^2 \frac{k\pi}{L} x dx}, \quad \text{for } k = 1, 2, \dots \quad (5.3.7)$$

These two formulae will be very helpful when we discuss generalized Fourier series.

### Example 2

Find the Fourier series expansion of

$$f(x) = x \quad \text{on } [-L, L]$$

$$\begin{aligned} a_k &= \frac{1}{L} \int_{-L}^L x \cos \frac{k\pi}{L} x dx \\ &= \frac{1}{L} \left[ \frac{L}{k\pi} x \sin \frac{k\pi}{L} x + \left( \frac{L}{k\pi} \right)^2 \cos \frac{k\pi}{L} x \right] \Big|_{-L}^L \end{aligned}$$

The first term vanishes at both ends and we have

$$= \frac{1}{L} \left( \frac{L}{k\pi} \right)^2 [\cos k\pi - \cos(-k\pi)] = 0.$$

$$\begin{aligned} b_k &= \frac{1}{L} \int_{-L}^L x \sin \frac{k\pi}{L} x dx \\ &= \frac{1}{L} \left[ -\frac{L}{k\pi} x \cos \frac{k\pi}{L} x + \left( \frac{L}{k\pi} \right)^2 \sin \frac{k\pi}{L} x \right] \Big|_{-L}^L. \end{aligned}$$

Now the second term vanishes at both ends and thus

$$b_k = -\frac{1}{k\pi} [L \cos k\pi - (-L) \cos(-k\pi)] = -\frac{2L}{k\pi} \cos k\pi = -\frac{2L}{k\pi} (-1)^k = \frac{2L}{k\pi} (-1)^{k+1}.$$

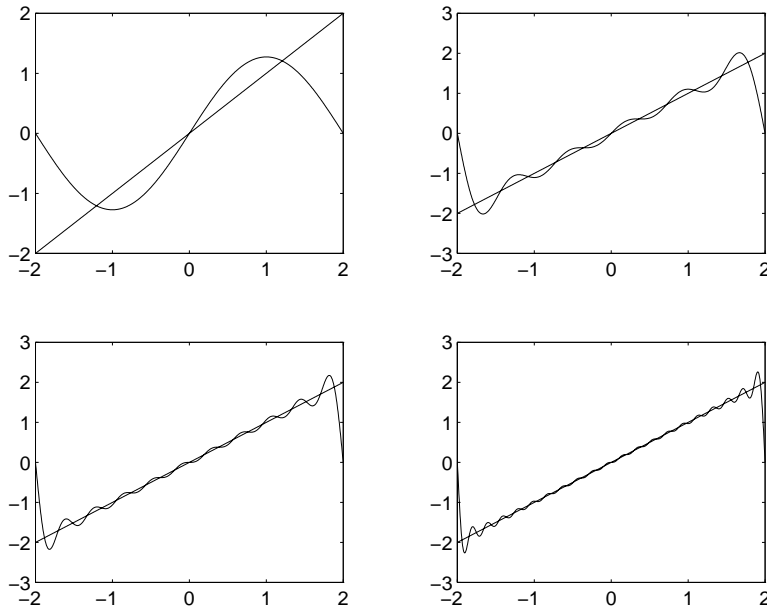

Figure 28: Graph of  $f(x) = x$  and the  $N^{\text{th}}$  partial sums for  $N = 1, 5, 10, 20$

Therefore the Fourier series is

$$x \sim \sum_{k=1}^{\infty} \frac{2L}{k\pi} (-1)^{k+1} \sin \frac{k\pi}{L} x. \quad (5.3.8)$$

In figure 28 we graphed the function  $f(x) = x$  and the  $N^{\text{th}}$  partial sum for  $N = 1, 5, 10, 20$ . Notice that the partial sums converge to  $f(x)$  except at the endpoints where we observe the well known Gibbs phenomenon. (The discontinuity produces spurious oscillations in the solution).

### Example 3

Find the Fourier coefficients of the expansion of

$$f(x) = \begin{cases} -1 & \text{for } -L < x < 0 \\ 1 & \text{for } 0 < x < L \end{cases} \quad (5.3.9)$$

$$\begin{aligned} a_k &= \frac{1}{L} \int_{-L}^0 (-1) \cos \frac{k\pi}{L} x dx + \frac{1}{L} \int_0^L 1 \cdot \cos \frac{k\pi}{L} x dx \\ &= -\frac{1}{L} \frac{L}{k\pi} \sin \frac{k\pi}{L} x \Big|_{-L}^0 + \frac{1}{L} \frac{L}{k\pi} \sin \frac{k\pi}{L} x \Big|_0^L = 0, \\ a_0 &= \frac{1}{L} \int_{-L}^0 (-1) dx + \frac{1}{L} \int_0^L 1 dx \\ &= -\frac{1}{L} x \Big|_{-L}^0 + \frac{1}{L} x \Big|_0^L = \frac{1}{L} (-L) + \frac{1}{L} \cdot L = 0, \end{aligned}$$

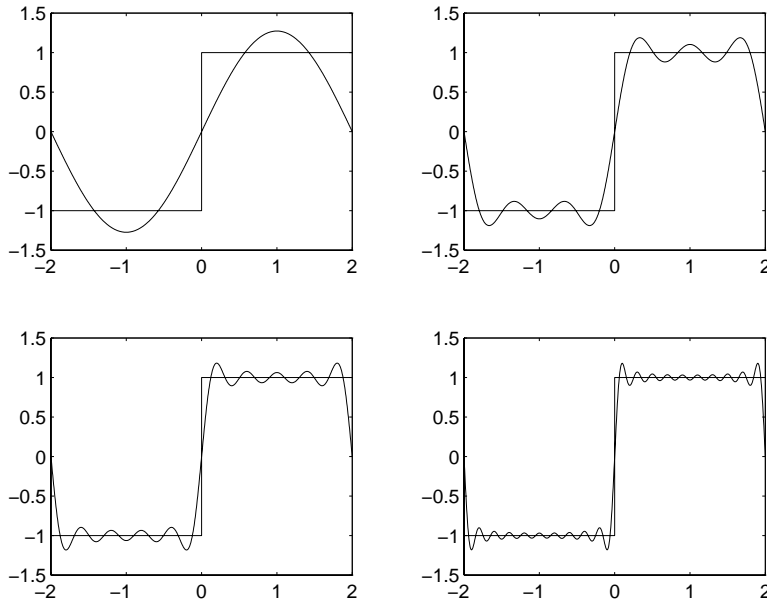

Figure 29: Graph of  $f(x)$  given in Example 3 and the  $N^{\text{th}}$  partial sums for  $N = 1, 5, 10, 20$

$$\begin{aligned}
 b_k &= \frac{1}{L} \int_{-L}^0 (-1) \sin \frac{k\pi}{L} x dx + \frac{1}{L} \int_0^L 1 \cdot \sin \frac{k\pi}{L} x dx \\
 &= \frac{1}{L} (-1) \left( -\frac{L}{k\pi} \right) \cos \frac{k\pi}{L} x \Big|_{-L}^0 + \frac{1}{L} \left( -\frac{L}{k\pi} \right) \cos \frac{k\pi}{L} x \Big|_0^L \\
 &= \frac{1}{k\pi} [1 - \cos(-k\pi)] - \frac{1}{k\pi} [\cos k\pi - 1] \\
 &= \frac{2}{k\pi} [1 - (-1)^k].
 \end{aligned}$$

Therefore the Fourier series is

$$f(x) \sim \sum_{k=1}^{\infty} \frac{2}{k\pi} [1 - (-1)^k] \sin \frac{k\pi}{L} x. \quad (5.3.10)$$

The graphs of  $f(x)$  and the  $N^{\text{th}}$  partial sums (for various values of  $N$ ) are given in figure 29.

In the last two examples, we have seen that  $a_k = 0$ . Next, we give an example where all the coefficients are nonzero.

#### Example 4

$$f(x) = \begin{cases} \frac{1}{L}x + 1 & -L < x < 0 \\ x & 0 < x < L \end{cases} \quad (5.3.11)$$

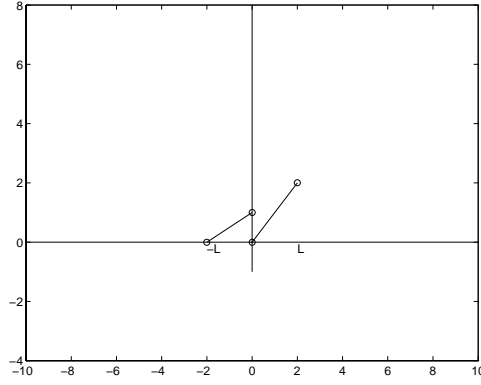

Figure 30: Graph of  $f(x)$  given in Example 4

$$\begin{aligned}
 a_0 &= \frac{1}{L} \int_{-L}^0 \left( \frac{1}{L}x + 1 \right) dx + \frac{1}{L} \int_0^L x dx \\
 &= \frac{1}{L^2} \frac{x^2}{2} \Big|_{-L}^0 + \frac{1}{L} x \Big|_{-L}^0 + \frac{1}{L} \frac{x^2}{2} \Big|_0^L \\
 &= -\frac{1}{2} + 1 + \frac{L}{2} = \frac{L+1}{2}, \\
 a_k &= \frac{1}{L} \int_{-L}^0 \left( \frac{1}{L}x + 1 \right) \cos \frac{k\pi}{L} x dx + \frac{1}{L} \int_0^L x \cos \frac{k\pi}{L} x dx \\
 &= \frac{1}{L^2} \left[ \frac{L}{k\pi} x \sin \frac{k\pi}{L} x + \left( \frac{L}{k\pi} \right)^2 \cos \frac{k\pi}{L} x \right] \Big|_{-L}^0 \\
 &\quad + \frac{1}{L} \frac{L}{k\pi} \sin \frac{k\pi}{L} x \Big|_{-L}^0 + \frac{1}{L} \left[ \frac{L}{k\pi} x \sin \frac{k\pi}{L} x + \left( \frac{L}{k\pi} \right)^2 \cos \frac{k\pi}{L} x \right] \Big|_0^L \\
 &= \frac{1}{L^2} \left( \frac{L}{k\pi} \right)^2 - \frac{1}{L^2} \left( \frac{L}{k\pi} \right)^2 \cos k\pi + \frac{1}{L} \left( \frac{L}{k\pi} \right)^2 \cos k\pi - \frac{1}{L} \left( \frac{L}{k\pi} \right)^2 \\
 &= \frac{1-L}{(k\pi)^2} - \frac{1-L}{(k\pi)^2} (-1)^k = \frac{1-L}{(k\pi)^2} (1 - (-1)^k),
 \end{aligned}$$

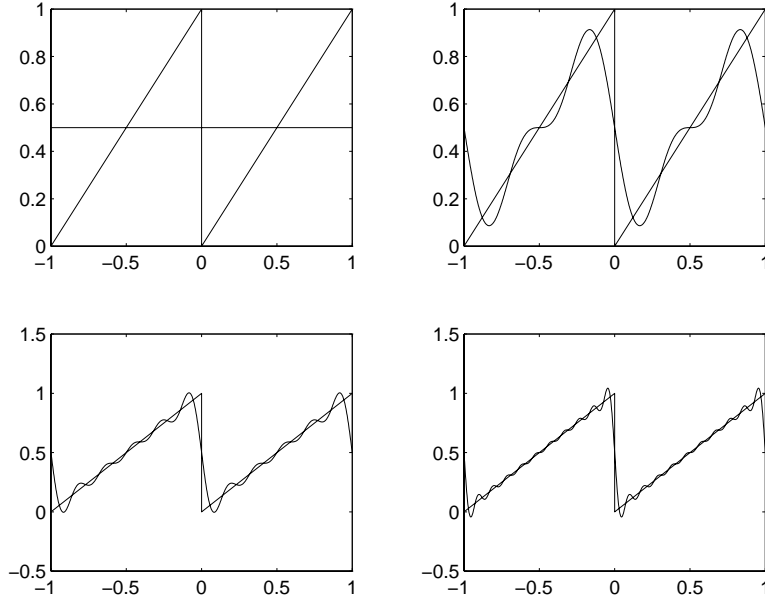

Figure 31: Graph of  $f(x)$  given by example 4 ( $L = 1$ ) and the  $N^{\text{th}}$  partial sums for  $N = 1, 5, 10, 20$ . Notice that for  $L = 1$  all cosine terms and odd sine terms vanish, thus the first term is the constant .5

$$\begin{aligned}
 b_k &= \frac{1}{L} \int_{-L}^0 \left( \frac{1}{L}x + 1 \right) \sin \frac{k\pi}{L}x dx + \frac{1}{L} \int_0^L x \sin \frac{k\pi}{L}x dx \\
 &= \frac{1}{L^2} \left[ -\frac{L}{k\pi}x \cos \frac{k\pi}{L}x + \left( \frac{L}{k\pi} \right)^2 \sin \frac{k\pi}{L}x \right] \Big|_{-L}^0 \\
 &\quad + \frac{1}{L} \frac{L}{k\pi} (-\cos \frac{k\pi}{L}x) \Big|_{-L}^0 + \frac{1}{L} \left[ -\frac{L}{k\pi}x \cos \frac{k\pi}{L}x + \left( \frac{L}{k\pi} \right)^2 \sin \frac{k\pi}{L}x \right] \Big|_0^L \\
 &= \frac{1}{L^2} \frac{L}{k\pi} (-L) \cos k\pi - \frac{1}{k\pi} + \frac{1}{k\pi} \cos k\pi - \frac{L}{k\pi} \cos k\pi \\
 &= -\frac{1}{k\pi} \left( 1 + (-1)^k L \right),
 \end{aligned}$$

therefore the Fourier series is

$$f(x) = \frac{L+1}{4} + \sum_{k=1}^{\infty} \left\{ \frac{1-L}{(k\pi)^2} [1 - (-1)^k] \cos \frac{k\pi}{L}x - \frac{1}{k\pi} [1 + (-1)^k L] \sin \frac{k\pi}{L}x \right\}$$

The sketches of  $f(x)$  and the  $N^{\text{th}}$  partial sums are given in figures 31-33 for various values of  $L$ .

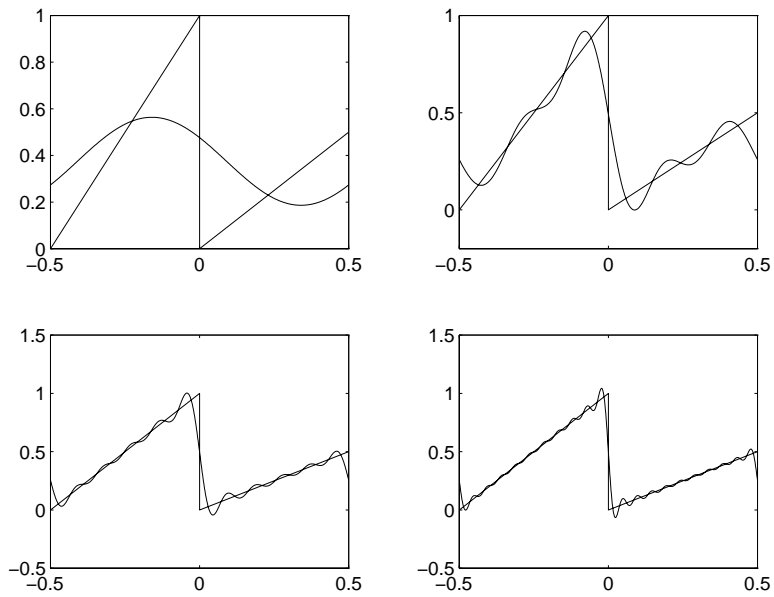

Figure 32: Graph of  $f(x)$  given by example 4 ( $L = 1/2$ ) and the  $N^{th}$  partial sums for  $N = 1, 5, 10, 20$

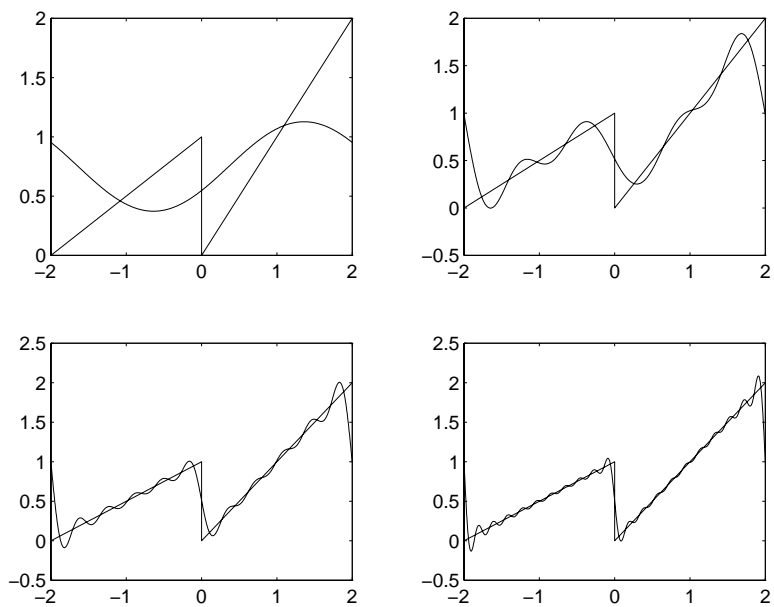

Figure 33: Graph of  $f(x)$  given by example 4 ( $L = 2$ ) and the  $N^{th}$  partial sums for  $N = 1, 5, 10, 20$

## Problems

1. For the following functions, sketch the Fourier series of  $f(x)$  on the interval  $[-L, L]$ . Compare  $f(x)$  to its Fourier series

a.  $f(x) = 1$

b.  $f(x) = x^2$

c.  $f(x) = e^x$

d.

$$f(x) = \begin{cases} \frac{1}{2}x & x < 0 \\ 3x & x > 0 \end{cases}$$

e.

$$f(x) = \begin{cases} 0 & x < \frac{L}{2} \\ x^2 & x > \frac{L}{2} \end{cases}$$

2. Sketch the Fourier series of  $f(x)$  on the interval  $[-L, L]$  and evaluate the Fourier coefficients for each

a.  $f(x) = x$

b.  $f(x) = \sin \frac{\pi}{L}x$

c.

$$f(x) = \begin{cases} 1 & |x| < \frac{L}{2} \\ 0 & |x| > \frac{L}{2} \end{cases}$$

3. Show that the Fourier series operation is linear, i.e. the Fourier series of  $\alpha f(x) + \beta g(x)$  is the sum of the Fourier series of  $f(x)$  and  $g(x)$  multiplied by the corresponding constant.



## 5.4 Relationship to Least Squares

In this section we show that the Fourier series expansion of  $f(x)$  gives the best approximation of  $f(x)$  in the sense of least squares. That is, if one minimizes the squares of differences between  $f(x)$  and the  $n^{\text{th}}$  partial sum of the series

$$\frac{a_0}{2} + \sum_{k=1}^{\infty} \left( a_k \cos \frac{k\pi}{L}x + b_k \sin \frac{k\pi}{L}x \right) \quad (5.4.1)$$

then the coefficients  $a_0$ ,  $a_k$  and  $b_k$  are exactly the Fourier coefficients given by (5.3.6)-(5.3.7).

Let  $I(a_0, a_1, \dots, a_n, b_1, b_2, \dots, b_n)$  be defined as the “sum” of the squares of the differences, i.e.

$$I = \int_{-L}^L [f(x) - s_n(x)]^2 dx \quad (5.4.2)$$

where  $s_n(x)$  is the  $n^{\text{th}}$  partial sum

$$s_n(x) = \frac{a_0}{2} + \sum_{k=1}^n \left( a_k \cos \frac{k\pi}{L}x + b_k \sin \frac{k\pi}{L}x \right). \quad (5.4.3)$$

In order to minimize the integral  $I$ , we have to set to zero each of the first partial derivatives,

$$\frac{\partial I}{\partial a_0} = 0, \quad (5.4.4)$$

$$\frac{\partial I}{\partial a_j} = 0, \quad j = 1, 2, \dots, n \quad (5.4.5)$$

$$\frac{\partial I}{\partial b_j} = 0, \quad j = 1, 2, \dots, n. \quad (5.4.6)$$

Differentiating the integral we find

$$\begin{aligned} \frac{\partial I}{\partial a_0} &= \int_{-L}^L 2[f(x) - s_n(x)] \frac{\partial}{\partial a_0} [f(x) - s_n(x)] dx \\ &= -2 \int_{-L}^L [f(x) - s_n(x)] \frac{1}{2} dx \\ &= - \int_{-L}^L \left[ f(x) - \frac{a_0}{2} - \sum_{k=1}^n \left( a_k \cos \frac{k\pi}{L}x + b_k \sin \frac{k\pi}{L}x \right) \right] dx \end{aligned} \quad (5.4.7)$$

Using the orthogonality of the function 1 to all  $\cos \frac{k\pi}{L}x$  and  $\sin \frac{k\pi}{L}x$  we have

$$\frac{\partial I}{\partial a_0} = - \int_{-L}^L f(x) dx + \frac{a_0}{2} 2L. \quad (5.4.8)$$

Combining (5.4.8) and (5.4.4) we have

$$a_0 = \frac{1}{L} \int_{-L}^L f(x) dx$$

which is (5.3.2).

If we differentiate the integral with respect to  $a_j$  for some  $j$ , then

$$\begin{aligned}\frac{\partial I}{\partial a_j} &= \int_{-L}^L 2[f(x) - s_n(x)] \frac{\partial}{\partial a_j} \left[ f(x) - \frac{a_0}{2} - \sum_{k=1}^n \left( a_k \cos \frac{k\pi}{L}x + b_k \sin \frac{k\pi}{L}x \right) \right] dx \\ &= 2 \int_{-L}^L [f(x) - s_n(x)] \left( -\cos \frac{j\pi}{L}x \right) dx\end{aligned}\tag{5.4.9}$$

Now we use the orthogonality of  $\cos \frac{j\pi}{L}x$  to get

$$0 = \frac{\partial I}{\partial a_j} = -2 \int_{-L}^L \left[ f(x) - a_j \cos \frac{j\pi}{L}x \right] \cos \frac{j\pi}{L}x dx.$$

Therefore

$$2 \int_{-L}^L a_j \cos^2 \frac{j\pi}{L}x dx = 2 \int_{-L}^L f(x) \cos \frac{j\pi}{L}x dx.$$

Solving for  $a_j$  yields (5.3.6).

Similarly

$$\frac{\partial I}{\partial b_j} = 0$$

will lead to

$$\int_{-L}^L b_j \sin^2 \frac{j\pi}{L}x dx = \int_{-L}^L f(x) \sin \frac{j\pi}{L}x dx$$

which gives (5.3.7).

## 5.5 Convergence

If  $f(x)$  is piecewise smooth on  $[-L, L]$  then the series converges to either the periodic extension of  $f(x)$ , where the periodic extension is continuous, or to the average of the two limits, where the periodic extension has a jump discontinuity.

It is always helpful to give several examples and sketches.

### Example 5

Given the function

$$f(x) = \begin{cases} 0, & x < 0 \\ 1, & x > 0. \end{cases}\tag{5.5.1}$$

The following figures show the sketch of  $f(x)$ , its periodic extension of period 2 and the sketch of the Fourier series of  $f(x)$ .

Notice that the sketch of  $f(x)$  on  $[-1, 1]$  is copied to  $[1, 3]$  and so on to the right and to the left.

Notice that the only difference is at the points of discontinuity  $x_n = \pm n$ ,  $n = 1, 2, \dots$

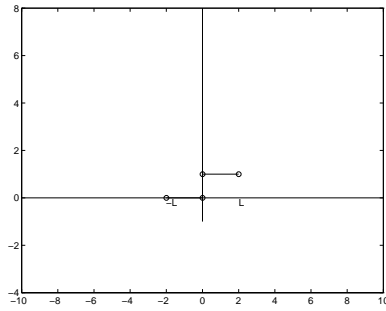

Figure 34: Sketch of  $f(x)$  given in Example 5

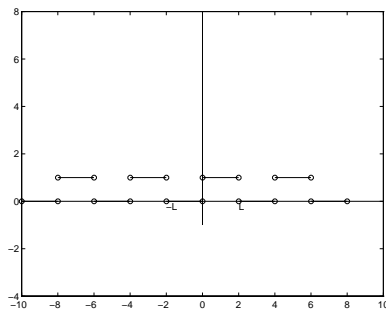

Figure 35: Sketch of the periodic extension

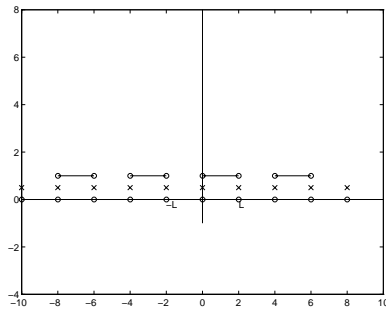

Figure 36: Sketch of the Fourier series

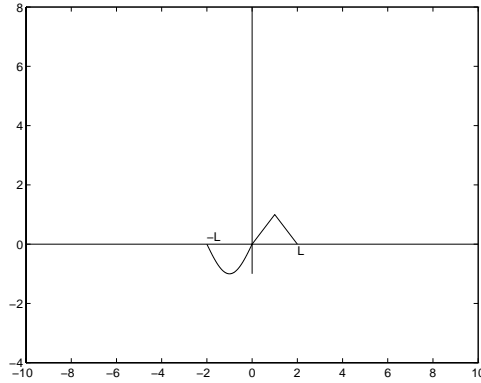

Figure 37: Sketch of  $f(x)$  given in Example 6

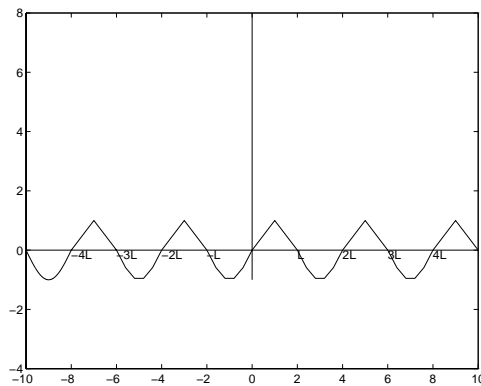

Figure 38: Sketch of the periodic extension

### Example 6

$$f(x) = \begin{cases} \sin \frac{\pi}{L}x, & -L < x < 0 \\ x, & 0 < x < \frac{L}{2} \\ L - x, & \frac{L}{2} < x < L \end{cases} \quad (5.5.2)$$

The Fourier series will be exactly the same since the periodic extension has no jump discontinuity. See Figure 37 for the sketch of  $f(x)$  and Figure 38 for the sketch of the periodic extension.

## 5.6 Fourier Cosine and Sine Series

In the examples in the last section we have seen Fourier series for which all  $a_k$  are zero. In such a case the Fourier series includes only sine functions. Such a series is called a Fourier sine series. The problems discussed in the previous chapter led to Fourier sine series or Fourier cosine series depending on the boundary conditions.

Let us now recall the definition of odd and even functions. A function  $f(x)$  is called odd if

$$f(-x) = -f(x) \quad (5.6.1)$$

and even, if

$$f(-x) = f(x). \quad (5.6.2)$$

Since  $\sin kx$  is an odd function, the sum is also an odd function, therefore a function  $f(x)$  having a Fourier sine series expansion is odd. Similarly, an even function will have a Fourier cosine series expansion.

Example 7

$$f(x) = x, \quad \text{on } [-L, L]. \quad (5.6.3)$$

The function is odd and thus the Fourier series expansion will have only sine terms, i.e. all  $a_k = 0$ . In fact we have found in one of the examples in the previous section that

$$f(x) \sim \sum_{k=1}^{\infty} \frac{2L}{k\pi} (-1)^{k+1} \sin \frac{k\pi}{L} x \quad (5.6.4)$$

Example 8

$$f(x) = x^2 \quad \text{on } [-L, L]. \quad (5.6.5)$$

The function is even and thus all  $b_k$  must be zero.

$$a_0 = \frac{1}{L} \int_{-L}^L x^2 dx = \frac{2}{L} \int_0^L x^2 dx = \frac{2}{L} \frac{x^3}{3} \Big|_0^L = \frac{2L^2}{3}, \quad (5.6.6)$$

$$a_k = \frac{1}{L} \int_{-L}^L x^2 \cos \frac{k\pi}{L} x dx =$$

Use table of integrals

$$= \frac{1}{L} \left[ 2x \left( \frac{L}{k\pi} \right)^2 \cos \frac{k\pi}{L} x \Big|_{-L}^L + \left( \left( \frac{k\pi}{L} \right)^2 x^2 - 2 \right) \left( \frac{L}{k\pi} \right)^3 \sin \frac{k\pi}{L} x \Big|_{-L}^L \right].$$

The sine terms vanish at both ends and we have

$$a_k = \frac{1}{L} 4L \left( \frac{L}{k\pi} \right)^2 \cos k\pi = 4 \left( \frac{L}{k\pi} \right)^2 (-1)^k. \quad (5.6.7)$$

Notice that the coefficients of the Fourier sine series can be written as

$$b_k = \frac{2}{L} \int_0^L f(x) \sin \frac{k\pi}{L} x dx, \quad (5.6.8)$$

that is the integration is only on half the interval and the result is doubled. Similarly for the Fourier cosine series

$$a_k = \frac{2}{L} \int_0^L f(x) \cos \frac{k\pi}{L} x dx. \quad (5.6.9)$$

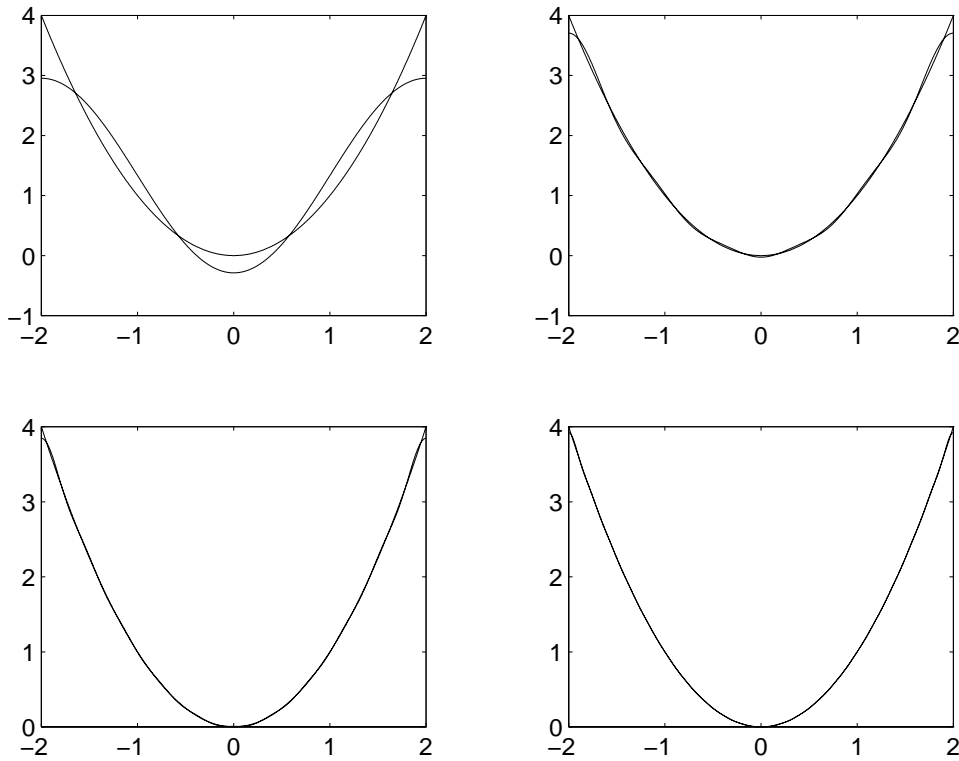

Figure 39: Graph of  $f(x) = x^2$  and the  $N^{\text{th}}$  partial sums for  $N = 1, 5, 10, 20$

If we go back to the examples in the previous chapter, we notice that the partial differential equation is solved on the interval  $[0, L]$ . If we end up with Fourier sine series, this means that the initial solution  $f(x)$  was extended as an odd function to  $[-L, 0]$ . It is the odd extension that we expand in Fourier series.

Example 9

Give a Fourier cosine series of

$$f(x) = x \quad \text{for} \quad 0 \leq x \leq L. \quad (5.6.10)$$

This means that  $f(x)$  is extended as an even function, i.e.

$$f(x) = \begin{cases} -x & -L \leq x \leq 0 \\ x & 0 \leq x \leq L \end{cases} \quad (5.6.11)$$

or

$$f(x) = |x| \quad \text{on} \quad [-L, L]. \quad (5.6.12)$$

The Fourier cosine series will have the following coefficients

$$a_0 = \frac{2}{L} \int_0^L x dx = \frac{2}{L} \left. \frac{1}{2} x^2 \right|_0^L = L, \quad (5.6.13)$$

$$a_k = \frac{2}{L} \int_0^L x \cos \frac{k\pi}{L} x dx = \frac{2}{L} \left[ \frac{L}{k\pi} x \sin \frac{k\pi}{L} x + \left( \frac{L}{k\pi} \right)^2 \cos \frac{k\pi}{L} x \right] \Big|_0^L$$

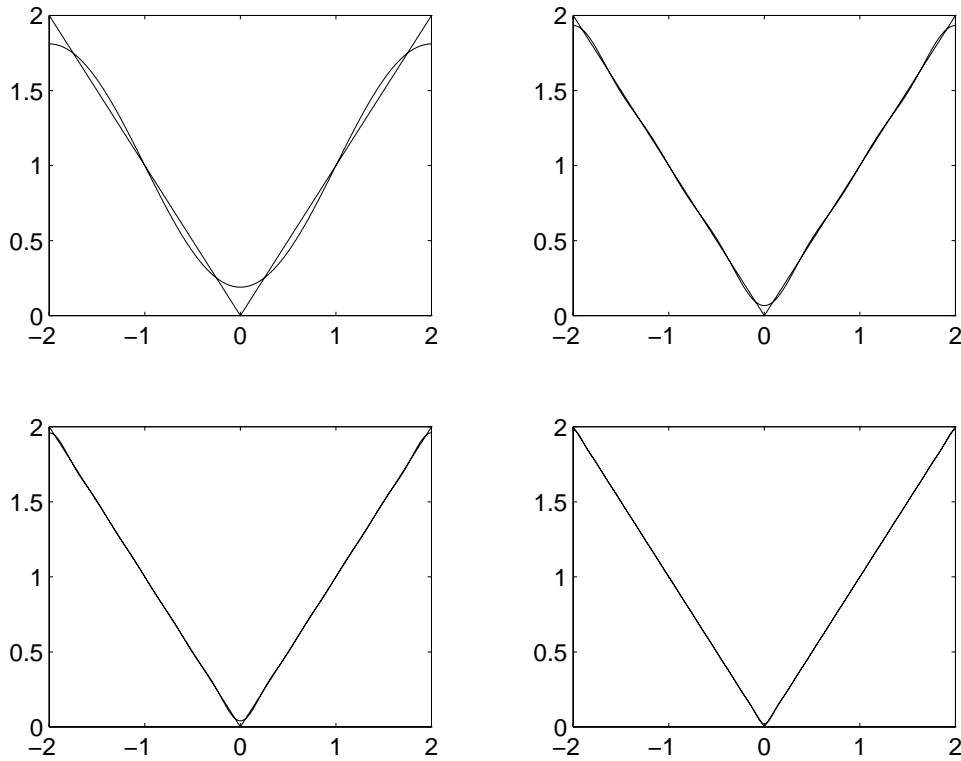

Figure 40: Graph of  $f(x) = |x|$  and the  $N^{\text{th}}$  partial sums for  $N = 1, 5, 10, 20$

$$= \frac{2}{L} \left[ 0 + \left( \frac{L}{k\pi} \right)^2 \cos k\pi - 0 - \left( \frac{L}{k\pi} \right)^2 \right] = \frac{2}{L} \left( \frac{L}{k\pi} \right)^2 [(-1)^k - 1]. \quad (5.6.14)$$

Therefore the series is

$$|x| \sim \frac{L}{2} + \sum_{k=1}^{\infty} \frac{2L}{(k\pi)^2} [(-1)^k - 1] \cos \frac{k\pi}{L} x. \quad (5.6.15)$$

In the next four figures we have sketched  $f(x) = |x|$  and the  $N^{\text{th}}$  partial sums for various values of  $N$ .

To sketch the Fourier cosine series of  $f(x)$ , we first sketch  $f(x)$  on  $[0, L]$ , then extend the sketch to  $[-L, L]$  as an even function, then extend as a periodic function of period  $2L$ . At points of discontinuity, take the average.

To sketch the Fourier sine series of  $f(x)$  we follow the same steps except that we take the odd extension.

#### Example 10

$$f(x) = \begin{cases} \sin \frac{\pi}{L} x, & -L < x < 0 \\ x, & 0 < x < \frac{L}{2} \\ L - x, & \frac{L}{2} < x < L \end{cases} \quad (5.6.16)$$

The Fourier cosine series and the Fourier sine series will ignore the definition on the interval  $[-L, 0]$  and take only the definition on  $[0, L]$ . The sketches follow on figures 41-43:

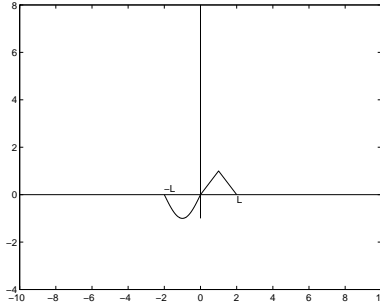

Figure 41: Sketch of  $f(x)$  given in Example 10

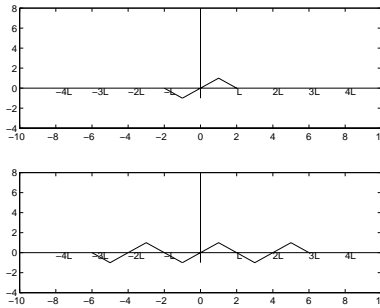

Figure 42: Sketch of the Fourier sine series and the periodic odd extension

Notes:

1. The Fourier series of a piecewise smooth function  $f(x)$  is continuous if and only if  $f(x)$  is continuous and  $f(-L) = f(L)$ .
2. The Fourier cosine series of a piecewise smooth function  $f(x)$  is continuous if and only if  $f(x)$  is continuous. (The condition  $f(-L) = f(L)$  is automatically satisfied.)
3. The Fourier sine series of a piecewise smooth function  $f(x)$  is continuous if and only if  $f(x)$  is continuous and  $f(0) = f(L)$ .

### Example 11

The previous example was for a function satisfying this condition. Suppose we have the

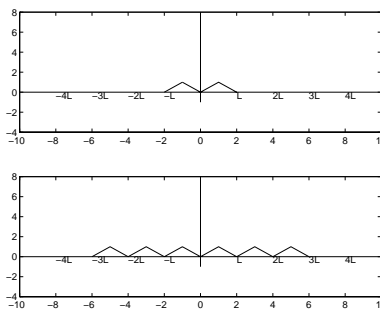

Figure 43: Sketch of the Fourier cosine series and the periodic even extension



following  $f(x)$

$$f(x) = \begin{cases} 0 & -L < x < 0 \\ x & 0 < x < L \end{cases} \quad (5.6.17)$$

The sketches of  $f(x)$ , its odd extension and its Fourier sine series are given in figures 44-46 correspondingly.

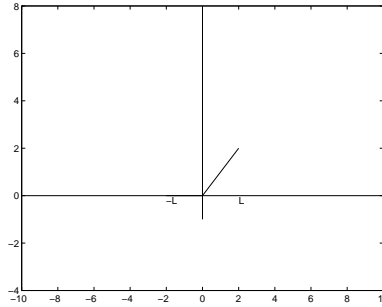

Figure 44: Sketch of  $f(x)$  given by example 11

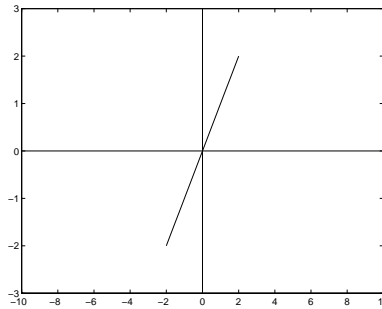

Figure 45: Sketch of the odd extension of  $f(x)$

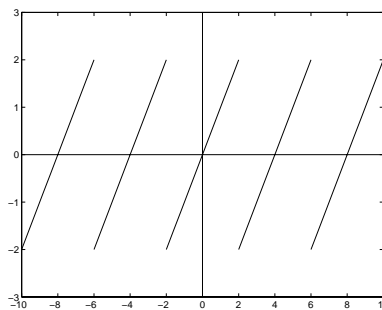

Figure 46: Sketch of the Fourier sine series is not continuous since  $f(0) \neq f(L)$

## Problems

1. For each of the following functions
  - i. Sketch  $f(x)$
  - ii. Sketch the Fourier series of  $f(x)$
  - iii. Sketch the Fourier sine series of  $f(x)$
  - iv. Sketch the Fourier cosine series of  $f(x)$

a.  $f(x) = \begin{cases} x & x < 0 \\ 1 + x & x > 0 \end{cases}$

b.  $f(x) = e^x$

c.  $f(x) = 1 + x^2$

d.  $f(x) = \begin{cases} \frac{1}{2}x + 1 & -2 < x < 0 \\ x & 0 < x < 2 \end{cases}$

2. Sketch the Fourier sine series of

$$f(x) = \cos \frac{\pi}{L}x.$$

Roughly sketch the sum of the first three terms of the Fourier sine series.

3. Sketch the Fourier cosine series and evaluate its coefficients for

$$f(x) = \begin{cases} 1 & x < \frac{L}{6} \\ 3 & \frac{L}{6} < x < \frac{L}{2} \\ 0 & \frac{L}{2} < x \end{cases}$$

4. Fourier series can be defined on other intervals besides  $[-L, L]$ . Suppose  $g(y)$  is defined on  $[a, b]$  and periodic with period  $b - a$ . Evaluate the coefficients of the Fourier series.

5. Expand

$$f(x) = \begin{cases} 1 & 0 < x < \frac{\pi}{2} \\ 0 & \frac{\pi}{2} < x < \pi \end{cases}$$

in a series of  $\sin nx$ .

- a. Evaluate the coefficients explicitly.
- b. Graph the function to which the series converges to over  $-2\pi < x < 2\pi$ .

## 5.7 Term by Term Differentiation

In order to check that the solution obtained by the method of separation of variables satisfies the PDE, one must be able to differentiate the infinite series.

1. A Fourier series that is continuous can be differentiated term by term if  $f'(x)$  is piecewise smooth. The result of the differentiation is the Fourier series of  $f'(x)$ .
2. A Fourier cosine series that is continuous can be differentiated term by term if  $f'(x)$  is piecewise smooth. The result of the differentiation is the Fourier sine series of  $f'(x)$ .
3. A Fourier sine series that is continuous can be differentiated term by term if  $f'(x)$  is piecewise smooth and  $f(0) = f(L) = 0$ . The result of the differentiation is the Fourier cosine series of  $f'(x)$ .

Note that if  $f(x)$  does not vanish at  $x = 0$  and  $x = L$  then the result of differentiation is given by the following formula:

$$f'(x) \sim \frac{1}{L} [f(L) - f(0)] + \sum_{n=1}^{\infty} \left\{ \frac{n\pi}{L} b_n + \frac{2}{L} [(-1)^n f(L) - f(0)] \right\} \cos \frac{n\pi}{L} x. \quad (5.7.1)$$

Note that if  $f(L) = f(0) = 0$  the above equation reduces to term by term differentiation.

### Example 12

Given the Fourier sine series of  $f(x) = x$ ,

$$x \sim 2 \sum_{n=1}^{\infty} \frac{L}{n\pi} (-1)^{n+1} \sin \frac{n\pi}{L} x. \quad (5.7.2)$$

Since  $f(L) = L \neq 0$ , we get upon differentiation using (5.7.1)

$$1 \sim \frac{1}{L} [L - 0] + \sum_{n=1}^{\infty} \left\{ \frac{n\pi}{L} \underbrace{2 \frac{L}{n\pi} (-1)^{n+1}}_{b_n} + \frac{2}{L} (-1)^n L \right\} \cos \frac{n\pi}{L} x$$

The term in braces is equal

$$2(-1)^{n+1} + 2(-1)^n = 0.$$

Therefore the infinite series vanishes and one gets

$$1 \sim 1,$$

that is, the Fourier cosine series of the constant function 1 is 1.

## Problems

1. Given the Fourier sine series

$$\cos \frac{\pi}{L}x \sim \sum_{n=1}^{\infty} b_n \sin \frac{n\pi}{L}x$$

$$b_n = \begin{cases} 0 & n \text{ is odd} \\ \frac{4n}{\pi(n^2 - 1)} & n \text{ is even} \end{cases}$$

Determine the Fourier cosine series of  $\sin \frac{\pi}{L}x$ .

2. Consider

$$\sinh x \sim \sum_{n=1}^{\infty} a_n \sin nx.$$

Determine the coefficients  $a_n$  by differentiating twice.

## 5.8 Term by Term Integration

A Fourier series of a piecewise smooth function  $f(x)$  can always be integrated term by term and the result is a convergent infinite series that always converges to  $\int_{-L}^L f(x)dx$  even if the original series has jumps.

### Example 13

The Fourier series of  $f(x) = 1$  is

$$1 \sim \frac{4}{\pi} \sum_{n=1,3,\dots} \frac{1}{n} \sin \frac{n\pi}{L}x \quad (5.8.1)$$

Integrate term by term from 0 to  $x$  gives

$$\begin{aligned} x - 0 &\sim -\frac{4}{\pi} \sum_{n=1,3,\dots} \frac{1}{n} \frac{L}{n\pi} \cos \frac{n\pi}{L}x \Big|_0^x \\ &= -\frac{4}{\pi} \sum_{n=1,3,\dots} \frac{L}{n^2\pi} \cos \frac{n\pi}{L}x + \frac{4}{\pi} \left[ \frac{L}{1^2\pi} + \frac{L}{3^2\pi} + \frac{L}{5^2\pi} + \dots \right] \end{aligned} \quad (5.8.2)$$

The last sum is the constant term ( $n = 0$ ) of the Fourier cosine series of  $f(x) = x$ , which is

$$\frac{1}{L} \int_0^L x dx = \frac{L}{2}. \quad (5.8.3)$$

Therefore

$$x \sim \frac{L}{2} - \frac{4L}{\pi^2} \sum_{n=1,3,\dots} \frac{1}{n^2} \cos \frac{n\pi}{L}x. \quad (5.8.4)$$

We have also found, as a by-product, the sum of the following infinite series

$$\frac{4L}{\pi^2} \left[ \frac{1}{1^2} + \frac{1}{3^2} + \dots \right] = \frac{L}{2}$$

or

$$\frac{1}{1^2} + \frac{1}{3^2} + \dots = \frac{\pi^2}{8}. \quad (5.8.5)$$

A second integration gives the Fourier sine series of

$$\begin{aligned} &\frac{x^2}{2} - \frac{L}{2}x \\ \frac{x^2}{2} &\sim \frac{L}{2}x - \frac{4L^2}{\pi^3} \sum_{n=1,3,\dots} \frac{1}{n^3} \sin \frac{n\pi}{L}x \end{aligned}$$

In order to get the Fourier sine series of  $x^2$ , one must substitute the sine series of  $x$  in the above and multiply the new right hand side by 2.

## Problems

1. Consider

$$x^2 \sim \sum_{n=1}^{\infty} a_n \sin \frac{n\pi}{L}x$$

a. Determine  $a_n$  by integration of the Fourier sine series of  $f(x) = 1$ , i.e. the series

$$1 \sim \frac{4}{\pi} \sum_{n=1}^{\infty} \frac{1}{2n-1} \sin \frac{2n-1}{L}\pi x$$

b. Derive the Fourier cosine series of  $x^3$  from this.

2. Suppose that

$$\cosh x \sim \sum_{n=1}^{\infty} b_n \sin \frac{n\pi}{L}x$$

a. Determine the coefficients  $b_n$  by differentiating twice.

b. Determine  $b_n$  by integrating twice.

3. Evaluate

$$\sum_{n=1}^{\infty} \frac{1}{(2n-1)^2}$$

by using the integration of Fourier sine series of  $f(x) = 1$  (see problem 1 part a.)

## 5.9 Full solution of Several Problems

In this section we give the Fourier coefficients for each of the solutions in the previous chapter.

### Example 14

$$u_t = ku_{xx}, \quad (5.9.1)$$

$$u(0, t) = 0, \quad (5.9.2)$$

$$u(L, t) = 0, \quad (5.9.3)$$

$$u(x, 0) = f(x). \quad (5.9.4)$$

The solution given in the previous chapter is

$$u(x, t) = \sum_{n=1}^{\infty} b_n e^{-k(\frac{n\pi}{L})^2 t} \sin \frac{n\pi}{L} x. \quad (5.9.5)$$

Upon substituting  $t = 0$  in (5.9.5) and using (5.9.4) we find that

$$f(x) = \sum_{n=1}^{\infty} b_n \sin \frac{n\pi}{L} x, \quad (5.9.6)$$

that is  $b_n$  are the coefficients of the expansion of  $f(x)$  into Fourier sine series. Therefore

$$b_n = \frac{2}{L} \int_0^L f(x) \sin \frac{n\pi}{L} x dx. \quad (5.9.7)$$

### Example 15

$$u_t = ku_{xx}, \quad (5.9.8)$$

$$u(0, t) = u(L, t), \quad (5.9.9)$$

$$u_x(0, t) = u_x(L, t), \quad (5.9.10)$$

$$u(x, 0) = f(x). \quad (5.9.11)$$

The solution found in the previous chapter is

$$u(x, t) = \frac{a_0}{2} + \sum_{n=1}^{\infty} (a_n \cos \frac{2n\pi}{L} x + b_n \sin \frac{2n\pi}{L} x) e^{-k(\frac{2n\pi}{L})^2 t}, \quad (5.9.12)$$

As in the previous example, we take  $t = 0$  in (5.9.12) and compare with (5.9.11) we find that

$$f(x) = \frac{a_0}{2} + \sum_{n=1}^{\infty} (a_n \cos \frac{2n\pi}{L} x + b_n \sin \frac{2n\pi}{L} x). \quad (5.9.13)$$

Therefore (notice that the period is  $L$ )

$$a_n = \frac{2}{L} \int_0^L f(x) \cos \frac{2n\pi}{L} x dx, \quad n = 0, 1, 2, \dots \quad (5.9.14)$$

$$b_n = \frac{2}{L} \int_0^L f(x) \sin \frac{2n\pi}{L} x dx, \quad n = 1, 2, \dots \quad (5.9.15)$$

(Note that  $\int_0^L \sin^2 \frac{2n\pi}{L} x dx = \frac{L}{2}$ )

### Example 16

Solve Laplace's equation inside a rectangle:

$$u_{xx} + u_{yy} = 0, \quad 0 \leq x \leq L, \quad 0 \leq y \leq H, \quad (5.9.16)$$

subject to the boundary conditions:

$$u(0, y) = g_1(y), \quad (5.9.17)$$

$$u(L, y) = g_2(y), \quad (5.9.18)$$

$$u(x, 0) = f_1(x), \quad (5.9.19)$$

$$u(x, H) = f_2(x). \quad (5.9.20)$$

Note that this is the first problem for which the boundary conditions are inhomogeneous. We will show that  $u(x, y)$  can be computed by summing up the solutions of the following four problems each having 3 homogeneous boundary conditions:

Problem 1:

$$u_{xx}^1 + u_{yy}^1 = 0, \quad 0 \leq x \leq L, \quad 0 \leq y \leq H, \quad (5.9.21)$$

subject to the boundary conditions:

$$u^1(0, y) = g_1(y), \quad (5.9.22)$$

$$u^1(L, y) = 0, \quad (5.9.23)$$

$$u^1(x, 0) = 0, \quad (5.9.24)$$

$$u^1(x, H) = 0. \quad (5.9.25)$$

Problem 2:

$$u_{xx}^2 + u_{yy}^2 = 0, \quad 0 \leq x \leq L, \quad 0 \leq y \leq H, \quad (5.9.26)$$

subject to the boundary conditions:

$$u^2(0, y) = 0, \quad (5.9.27)$$

$$u^2(L, y) = g_2(y), \quad (5.9.28)$$

$$u^2(x, 0) = 0, \quad (5.9.29)$$

$$u^2(x, H) = 0. \quad (5.9.30)$$

Problem 3:

$$u_{xx}^3 + u_{yy}^3 = 0, \quad 0 \leq x \leq L, \quad 0 \leq y \leq H, \quad (5.9.31)$$



subject to the boundary conditions:

$$u^3(0, y) = 0, \quad (5.9.32)$$

$$u^3(L, y) = 0, \quad (5.9.33)$$

$$u^3(x, 0) = f_1(x), \quad (5.9.34)$$

$$u^3(x, H) = 0. \quad (5.9.35)$$

Problem 4:

$$u_{xx}^4 + u_{yy}^4 = 0, \quad 0 \leq x \leq L, \quad 0 \leq y \leq H, \quad (5.9.36)$$

subject to the boundary conditions:

$$u^4(0, y) = 0, \quad (5.9.37)$$

$$u^4(L, y) = 0, \quad (5.9.38)$$

$$u^4(x, 0) = 0, \quad (5.9.39)$$

$$u^4(x, H) = f_2(x). \quad (5.9.40)$$

It is clear that since  $u^1, u^2, u^3$ , and  $u^4$  all satisfy Laplace's equation, then

$$u = u^1 + u^2 + u^3 + u^4$$

also satisfies that same PDE (the equation is linear and the result follows from the principle of superposition.) It is also as straightforward to show that  $u$  satisfies the inhomogeneous boundary conditions (5.9.17)-(5.9.20).

We will solve only problem 3 and leave the other 3 problems as exercises.

Separation of variables method applied to (5.9.31)-(5.9.35) leads to the following two ODEs

$$X'' + \lambda X = 0, \quad (5.9.41)$$

$$X(0) = 0, \quad (5.9.42)$$

$$X(L) = 0, \quad (5.9.43)$$

$$Y'' - \lambda Y = 0, \quad (5.9.44)$$

$$Y(H) = 0. \quad (5.9.45)$$

The solution of the first was obtained earlier, see (4.1.20)-(4.1.21)

$$X_n = \sin \frac{n\pi}{L}x, \quad (5.9.46)$$

$$\lambda_n = \left(\frac{n\pi}{L}\right)^2, \quad n = 1, 2, \dots \quad (5.9.47)$$

Using these eigenvalues in (5.9.44) we have

$$Y_n'' - \left(\frac{n\pi}{L}\right)^2 Y_n = 0 \quad (5.9.48)$$

which has a solution

$$Y_n = A_n \cosh \frac{n\pi}{L}y + B_n \sinh \frac{n\pi}{L}y. \quad (5.9.49)$$

Because of the boundary condition and the fact that  $\sinh y$  vanishes at zero, we prefer to write the solution as a shifted hyperbolic sine (see (4.1.15)), i.e.

$$Y_n = A_n \sinh \frac{n\pi}{L}(y - H). \quad (5.9.50)$$

Clearly, this vanishes at  $y = H$  and thus (5.9.45) is also satisfied. Therefore, we have

$$u^3(x, y) = \sum_{n=1}^{\infty} A_n \sinh \frac{n\pi}{L}(y - H) \sin \frac{n\pi}{L}x. \quad (5.9.51)$$

In the exercises, the reader will have to show that

$$u^1(x, y) = \sum_{n=1}^{\infty} B_n \sinh \frac{n\pi}{H}(x - L) \sin \frac{n\pi}{H}y, \quad (5.9.52)$$

$$u^2(x, y) = \sum_{n=1}^{\infty} C_n \sinh \frac{n\pi}{H}x \sin \frac{n\pi}{H}y, \quad (5.9.53)$$

$$u^4(x, y) = \sum_{n=1}^{\infty} D_n \sinh \frac{n\pi}{L}y \sin \frac{n\pi}{L}x. \quad (5.9.54)$$

To get  $A_n, B_n, C_n,$  and  $D_n$  we will use the inhomogeneous boundary condition in each problem:

$$A_n \sinh \frac{n\pi}{L}(-H) = \frac{2}{L} \int_0^L f_1(x) \sin \frac{n\pi}{L}x dx, \quad (5.9.55)$$

$$B_n \sinh \frac{n\pi}{H}(-L) = \frac{2}{H} \int_0^H g_1(y) \sin \frac{n\pi}{H}y dy, \quad (5.9.56)$$

$$C_n \sinh \frac{n\pi L}{H} = \frac{2}{H} \int_0^H g_2(y) \sin \frac{n\pi}{H}y dy, \quad (5.9.57)$$

$$D_n \sinh \frac{n\pi H}{L} = \frac{2}{L} \int_0^L f_2(x) \sin \frac{n\pi}{L}x dx. \quad (5.9.58)$$

### Example 17

Solve Laplace's equation inside a circle of radius  $a$ ,

$$\nabla^2 u = \frac{1}{r} \frac{\partial}{\partial r} \left( r \frac{\partial u}{\partial r} \right) + \frac{1}{r^2} \frac{\partial^2 u}{\partial \theta^2} = 0, \quad (5.9.59)$$

subject to

$$u(a, \theta) = f(\theta). \quad (5.9.60)$$

Let

$$u(r, \theta) = R(r)\Theta(\theta), \quad (5.9.61)$$

then

$$\Theta \frac{1}{r} (rR')' + \frac{1}{r^2} R\Theta'' = 0.$$

Multiply by  $\frac{r^2}{R\Theta}$

$$\frac{r (rR')'}{R} = -\frac{\Theta''}{\Theta} = \mu. \quad (5.9.62)$$

Thus the ODEs are

$$\Theta'' + \mu\Theta = 0, \quad (5.9.63)$$

and

$$r(rR')' - \mu R = 0. \quad (5.9.64)$$

The solution must be periodic in  $\theta$  since we have a complete disk. Thus the boundary conditions for  $\Theta$  are

$$\Theta(0) = \Theta(2\pi), \quad (5.9.65)$$

$$\Theta'(0) = \Theta'(2\pi). \quad (5.9.66)$$

The solution of the  $\Theta$  equation is given by

$$\mu_0 = 0, \quad \Theta_0 = 1, \quad (5.9.67)$$

$$\mu_n = n^2, \quad \Theta_n = \begin{cases} \sin n\theta \\ \cos n\theta \end{cases} \quad n = 1, 2, \dots \quad (5.9.68)$$

The only boundary condition for  $R$  is the boundedness, i.e.

$$|R(0)| < \infty. \quad (5.9.69)$$

The solution for the  $R$  equation is given by (see Euler's equation in any ODE book)

$$R_0 = C_0 \ln r + D_0, \quad (5.9.70)$$

$$R_n = C_n r^{-n} + D_n r^n. \quad (5.9.71)$$

Since  $\ln r$  and  $r^{-n}$  are not finite at  $r = 0$  (which is in the domain), we must have  $C_0 = C_n = 0$ . Therefore

$$u(r, \theta) = \frac{1}{2}\alpha_0 + \sum_{n=1}^{\infty} r^n (\alpha_n \cos n\theta + \beta_n \sin n\theta). \quad (5.9.72)$$

Using the inhomogeneous boundary condition

$$f(\theta) = u(a, \theta) = \frac{1}{2}\alpha_0 + \sum_{n=1}^{\infty} a^n (\alpha_n \cos n\theta + \beta_n \sin n\theta), \quad (5.9.73)$$

we have the coefficients (Fourier series expansion of  $f(\theta)$ )

$$\alpha_0 = \frac{1}{\pi} \int_0^{2\pi} f(\theta) d\theta, \quad (5.9.74)$$

$$\alpha_n = \frac{1}{\pi a^n} \int_0^{2\pi} f(\theta) \cos n\theta d\theta, \quad (5.9.75)$$

$$\beta_n = \frac{1}{\pi a^n} \int_0^{2\pi} f(\theta) \sin n\theta d\theta. \quad (5.9.76)$$

The boundedness condition at zero is necessary only if  $r = 0$  is part of the domain.

In the next example, we show how to overcome the Gibbs phenomenon resulting from discontinuities in the boundary conditions.

#### Example 18

Solve Laplace's equation inside a rectangular domain  $(0, a) \times (0, b)$  with nonzero Dirichlet boundary conditions on each side, i.e.

$$\nabla^2 u = 0 \quad (5.9.77)$$

$$u(x, 0) = g_1(x), \quad (5.9.78)$$

$$u(a, y) = g_2(y), \quad (5.9.79)$$

$$u(x, b) = g_3(x), \quad (5.9.80)$$

$$u(0, y) = g_4(y), \quad (5.9.81)$$

assuming that  $g_1(a) \neq g_2(0)$  and so forth at other corners of the rectangle. This discontinuity causes spurious oscillations in the solution, i.e. we have Gibbs phenomenon.

The way to overcome the problem is to decompose  $u$  to a sum of two functions

$$u = v + w \quad (5.9.82)$$

where  $w$  is bilinear function and thus satisfies  $\nabla^2 w = 0$ , and  $v$  is harmonic with boundary conditions vanishing at the corners, i.e.

$$\nabla^2 v = 0 \quad (5.9.83)$$

$$v = g - w, \quad \text{on the boundary.} \quad (5.9.84)$$

In order to get zero boundary conditions on the corners, we must have the function  $w$  be of the form

$$w(x, y) = g(0, 0) \frac{(a-x)(b-y)}{ab} + g(a, 0) \frac{x(b-y)}{ab} + g(a, b) \frac{xy}{ab} + g(0, b) \frac{(a-x)y}{ab}, \quad (5.9.85)$$

and

$$g(x, 0) = g_1(x) \quad (5.9.86)$$

$$g(a, y) = g_2(y) \quad (5.9.87)$$

$$g(x, b) = g_3(x) \quad (5.9.88)$$

$$g(0, y) = g_4(y). \quad (5.9.89)$$

It is easy to show that this  $w$  satisfies Laplace's equation and that  $v$  vanishes at the corners and therefore the discontinuities disappear.

## Problems

1. Solve the heat equation

$$u_t = ku_{xx}, \quad 0 < x < L, \quad t > 0,$$

subject to the boundary conditions

$$u(0, t) = u(L, t) = 0.$$

Solve the problem subject to the initial value:

a.  $u(x, 0) = 6 \sin \frac{9\pi}{L}x.$

b.  $u(x, 0) = 2 \cos \frac{3\pi}{L}x.$

2. Solve the heat equation

$$u_t = ku_{xx}, \quad 0 < x < L, \quad t > 0,$$

subject to

$$u_x(0, t) = 0, \quad t > 0$$

$$u_x(L, t) = 0, \quad t > 0$$

a.  $u(x, 0) = \begin{cases} 0 & x < \frac{L}{2} \\ 1 & x > \frac{L}{2} \end{cases}$

b.  $u(x, 0) = 6 + 4 \cos \frac{3\pi}{L}x.$

3. Solve the eigenvalue problem

$$\phi'' = -\lambda\phi$$

subject to

$$\phi(0) = \phi(2\pi)$$

$$\phi'(0) = \phi'(2\pi)$$

4. Solve Laplace's equation inside a wedge of radius  $a$  and angle  $\alpha$ ,

$$\nabla^2 u = \frac{1}{r} \frac{\partial}{\partial r} \left( r \frac{\partial u}{\partial r} \right) + \frac{1}{r^2} \frac{\partial^2 u}{\partial \theta^2} = 0$$

subject to

$$u(a, \theta) = f(\theta),$$

$$u(r, 0) = u_\theta(r, \alpha) = 0.$$

5. Solve Laplace's equation inside a rectangle  $0 \leq x \leq L$ ,  $0 \leq y \leq H$  subject to
- $u_x(0, y) = u_x(L, y) = u(x, 0) = 0$ ,  $u(x, H) = f(x)$ .
  - $u(0, y) = g(y)$ ,  $u(L, y) = u_y(x, 0) = u(x, H) = 0$ .
  - $u(0, y) = u(L, y) = 0$ ,  $u(x, 0) - u_y(x, 0) = 0$ ,  $u(x, H) = f(x)$ .
6. Solve Laplace's equation outside a circular disk of radius  $a$ , subject to
- $u(a, \theta) = \ln 2 + 4 \cos 3\theta$ .
  - $u(a, \theta) = f(\theta)$ .
7. Solve Laplace's equation inside the quarter circle of radius 1, subject to
- $u_\theta(r, 0) = u(r, \pi/2) = 0$ ,  $u(1, \theta) = f(\theta)$ .
  - $u_\theta(r, 0) = u_\theta(r, \pi/2) = 0$ ,  $u_r(1, \theta) = g(\theta)$ .
  - $u(r, 0) = u(r, \pi/2) = 0$ ,  $u_r(1, \theta) = 1$ .
8. Solve Laplace's equation inside a circular annulus ( $a < r < b$ ), subject to
- $u(a, \theta) = f(\theta)$ ,  $u(b, \theta) = g(\theta)$ .
  - $u_r(a, \theta) = f(\theta)$ ,  $u_r(b, \theta) = g(\theta)$ .
9. Solve Laplace's equation inside a semi-infinite strip ( $0 < x < \infty$ ,  $0 < y < H$ ) subject to  $u_y(x, 0) = 0$ ,  $u_y(x, H) = 0$ ,  $u(0, y) = f(y)$ .
10. Consider the heat equation

$$u_t = u_{xx} + q(x, t), \quad 0 < x < L,$$

subject to the boundary conditions

$$u(0, t) = u(L, t) = 0.$$

Assume that  $q(x, t)$  is a piecewise smooth function of  $x$  for each positive  $t$ . Also assume that  $u$  and  $u_x$  are continuous functions of  $x$  and  $u_{xx}$  and  $u_t$  are piecewise smooth. Thus

$$u(x, t) = \sum_{n=1}^{\infty} b_n(t) \sin \frac{n\pi}{L}x.$$

Write the ordinary differential equation satisfied by  $b_n(t)$ .

11. Solve the following inhomogeneous problem

$$\frac{\partial u}{\partial t} = k \frac{\partial^2 u}{\partial x^2} + e^{-t} + e^{-2t} \cos \frac{3\pi}{L}x,$$

subject to

$$\begin{aligned}\frac{\partial u}{\partial x}(0, t) &= \frac{\partial u}{\partial x}(L, t) = 0, \\ u(x, 0) &= f(x).\end{aligned}$$

Hint : Look for a solution as a Fourier cosine series. Assume  $k \neq \frac{2L^2}{9\pi^2}$ .

12. Solve the wave equation by the method of separation of variables

$$\begin{aligned}u_{tt} - c^2 u_{xx} &= 0, & 0 < x < L, \\ u(0, t) &= 0, \\ u(L, t) &= 0, \\ u(x, 0) &= f(x), \\ u_t(x, 0) &= g(x).\end{aligned}$$

13. Solve the heat equation

$$u_t = 2u_{xx}, \quad 0 < x < L,$$

subject to the boundary conditions

$$u(0, t) = u_x(L, t) = 0,$$

and the initial condition

$$u(x, 0) = \sin \frac{3\pi}{2L}x.$$

14. Solve the heat equation

$$\frac{\partial u}{\partial t} = k \left( \frac{1}{r} \frac{\partial}{\partial r} \left( r \frac{\partial u}{\partial r} \right) + \frac{1}{r^2} \frac{\partial^2 u}{\partial \theta^2} \right)$$

inside a disk of radius  $a$  subject to the boundary condition

$$\frac{\partial u}{\partial r}(a, \theta, t) = 0,$$

and the initial condition

$$u(r, \theta, 0) = f(r, \theta)$$

where  $f(r, \theta)$  is a given function.

## SUMMARY

Fourier Series

$$f(x) \sim \frac{a_0}{2} + \sum_{n=1}^{\infty} \left( a_n \cos \frac{n\pi}{L}x + b_n \sin \frac{n\pi}{L}x \right)$$

$$a_k = \frac{1}{L} \int_{-L}^L f(x) \cos \frac{k\pi}{L}x dx \quad \text{for } k = 0, 1, 2, \dots$$

$$b_k = \frac{1}{L} \int_{-L}^L f(x) \sin \frac{k\pi}{L}x dx \quad \text{for } k = 1, 2, \dots$$

Solution of Euler's equation

$$r(rR)' - \lambda R = 0$$

For  $\lambda_0 = 0$  the solution is  $R_0 = C_1 \ln r + C_2$

For  $\lambda_n = n^2$  the solution is  $R_n = D_1 r^n + D_2 r^{-n}$ ,  $n = 1, 2, \dots$



## 6 Sturm-Liouville Eigenvalue Problem

### 6.1 Introduction

In the previous chapters, we introduced the method of separation of variables and gave several examples of constant coefficient partial differential equations. The method in these cases led to the second order ordinary differential equation

$$X''(x) + \lambda X(x) = 0$$

subject to a variety of boundary conditions. We showed that such boundary value problems have solutions (eigenfunctions  $X_n$ ) for certain discrete values of  $\lambda_n$  (eigenvalues).

In this chapter we summarize those results in a theorem and show how to use this theorem for linear partial differential equations NOT having constant coefficients. We start by giving several examples of such linear partial differential equations.

Example Heat flow in a nonuniform rod.

Recall that the temperature distribution in a rod is given by (1.3.7)

$$c(x)\rho(x)\frac{\partial u}{\partial t} = \frac{\partial}{\partial x} \left( K \frac{\partial u}{\partial x} \right) + S, \quad (6.1.1)$$

where  $c(x)$  is the specific heat,  $\rho(x)$  is the mass density and  $K(x)$  is the thermal conductivity. The method of separation of variables was only applied to homogeneous problems (nonhomogeneous problems will be discussed in Chapter 8). Therefore the only possibility for the source  $S$  is

$$S(x, t) = \alpha(x)u(x, t). \quad (6.1.2)$$

Such problems may arise in chemical reactions that generate heat ( $S > 0$ ) or remove heat ( $S < 0$ ). We now show how to separate the variables for (6.1.1) - (6.1.2). Let, as before,

$$u(x, t) = X(x)T(t)$$

be substituted in the PDE, then

$$c(x)\rho(x)X(x)\dot{T}(t) = T(t) (K(x)X'(x))' + \alpha(x)X(x)T(t). \quad (6.1.3)$$

Divide by  $c(x)\rho(x)X(x)T(t)$  then (6.1.3) becomes

$$\frac{\dot{T}(t)}{T(t)} = \frac{1}{c(x)\rho(x)} \frac{(K(x)X'(x))'}{X(x)} + \frac{\alpha(x)}{c(x)\rho(x)}. \quad (6.1.4)$$

Now the variables are separated, and therefore, as we have seen in Chapter 4,

$$\dot{T}(t) + \lambda T(t) = 0 \quad (6.1.5)$$

$$(K(x)X'(x))' + \alpha(x)X(x) + \lambda c(x)\rho(x)X(x) = 0. \quad (6.1.6)$$

Note the differences between these two ODE's and the constant coefficients case :

i. The  $T$  equation has no constant in the term containing  $\lambda$ , since that is no longer a constant.

ii. The  $X$  equation contains three terms. The first one is different than the constant coefficient case because  $K$  is a function of  $x$ . The second term is the result of the special form of inhomogeneity of the problem. The third term contains a function  $c(x)\rho(x)$  multiplying the second term of the constant coefficients case.

Remark : Note that if  $K$ ,  $c$ , and  $\rho$  were constants then (6.1.6) becomes

$$KX''(x) + \alpha(x)X(x) + \lambda c\rho X(x) = 0.$$

In this case one could go back to (6.1.4) and have  $\frac{c\rho}{K}$  on the  $T$  side. The question we will discuss in this chapter is : What can we conclude about the eigenvalues  $\lambda_n$  and the eigenfunctions  $X_n(x)$  of (6.1.6). Physically we know that if  $\alpha > 0$  some negative eigenvalues are possible. (Recall that if  $\lambda < 0$ ,  $T$  grows exponentially since the  $T$  equation (6.1.5) has the solution  $T(t) = ce^{-\lambda t}$ .)

Example      Circularly symmetric heat flow problem

Recall that heat flow in a disk of radius  $a$  can be written in polar coordinates as follows (Exercise 4, Section 5.9)

$$\frac{d}{dr} \left( r \frac{dR}{dr} \right) + \lambda r R(r) = 0, \quad 0 < r < a \quad (6.1.7)$$

$$|R(0)| < \infty. \quad (\text{singularity condition})$$

The coefficients are not constants in this case, even though the disk is uniform.

Definition 18. The Sturm - Liouville differential equation is of the form

$$\frac{d}{dx} \left( p(x) \frac{dX(x)}{dx} \right) + q(x)X(x) + \lambda \sigma(x)X(x) = 0, \quad a < x < b. \quad (6.1.8)$$

Examples :

- i.  $p = 1, q = 0, \sigma = 1$ ,                      see (4.1.8).
- ii.  $p = k, q = \alpha, \sigma = c\rho$ ,                      see (6.1.6).
- iii.  $p(r) = r, q = 0, \sigma(r) = r$ ,                      see (6.1.7).

The following boundary conditions were discussed

$$X(0) = X(L) = 0,$$

$$X'(0) = X(L) = 0,$$

$$X(0) = X'(L) = 0,$$

$$X'(0) = X'(L) = 0,$$

$$X(0) = 0, X(L) + X'(L) = 0, \quad (\text{Exercise 1e, Ch. 4.2})$$

$$X(0) = X(L), X'(0) = X'(L),$$

$$|X(0)| < \infty.$$

Definition 19. A Sturm-Liouville differential equation (6.1.8) along with the boundary conditions

$$\beta_1 X(a) + \beta_2 X'(a) = 0, \quad (6.1.9)$$

$$\beta_3 X(b) + \beta_4 X'(b) = 0. \quad (6.1.10)$$

where  $\beta_1, \beta_2, \beta_3,$  and  $\beta_4$  are real numbers is called a regular Sturm-Liouville problem, if the coefficients  $p(x), q(x),$  and  $\sigma(x)$  are real and continuous functions and if both  $p(x)$  and  $\sigma(x)$  are positive on  $[a, b]$ . Note that except periodic conditions and singularity, all other boundary conditions discussed are covered by the above set.

Theorem For a regular Sturm-Liouville problem the following is true

- i. All the eigenvalues  $\lambda$  are real
- ii. There exist an infinite number of eigenvalues

$$\lambda_1 < \lambda_2 < \dots < \lambda_n < \dots$$

- a. there is a smallest eigenvalue denoted by  $\lambda_1$
- b.  $\lambda_n \rightarrow \infty$  as  $n \rightarrow \infty$
- iii. Corresponding to each  $\lambda_n$  there is an eigenfunction  $X_n$  (unique up to an arbitrary multiplicative constant).  $X_n$  has exactly  $n - 1$  zeros in the open interval  $(a, b)$ . This is called oscillation theorem.
- iv. The eigenfunctions form a complete set, i.e. any smooth function  $f(x)$  can be represented as

$$f(x) \sim \sum_{n=1}^{\infty} a_n X_n(x). \quad (6.1.11)$$

This infinite series, called generalized Fourier series, converges to  $\frac{f(x_+) + f(x_-)}{2}$  if  $a_n$  are properly chosen.

- v. Eigenfunctions belonging to different eigenvalues are orthogonal relative to the weight  $\sigma$ , i.e.

$$\int_a^b \sigma(x) X_n(x) X_m(x) dx = 0, \quad \text{if } \lambda_n \neq \lambda_m. \quad (6.1.12)$$

- vi. Any eigenvalue can be related to its eigenfunction by the following, so called, Rayleigh quotient

$$\lambda = \frac{-p(x)X(x)X'(x)|_a^b + \int_a^b \{p(x)[X'(x)]^2 - q(x)X^2(x)\} dx}{\int_a^b \sigma(x)X^2(x)dx}. \quad (6.1.13)$$

The boundary conditions may simplify the boundary term in the numerator. The Rayleigh quotient can be used to approximate the eigenvalues and eigenfunctions. The proof and some remarks about generalizations will be given in the appendix.

Example

$$X'' + \lambda X = 0, \quad (6.1.14)$$

$$X(0) = 0, \quad (6.1.15)$$

$$X(L) = 0. \quad (6.1.16)$$

We have found that

$$\lambda_n = \left(\frac{n\pi}{L}\right)^2, \quad n = 1, 2, \dots \quad (6.1.17)$$

$$X_n = \sin \frac{n\pi}{L}x, \quad n = 1, 2, \dots \quad (6.1.18)$$

Clearly all eigenvalues are real. The smallest one is  $\lambda_1 = \left(\frac{\pi}{L}\right)^2$ . There is no largest as can be seen from (6.1.17). For each eigenvalue there is one eigenfunction. The eigenfunction  $X_1 = \sin \frac{\pi}{L}x$ , for example, does NOT vanish inside the interval  $(0, L)$ .  $X_2$  vanishes once inside the interval  $(0, L)$ , i.e.  $X_2 = 0$  for  $X = \frac{L}{2}$ . The generalized Fourier series in this case is the Fourier sine series and the coefficients are

$$a_n = \frac{\int_0^L f(x) \sin \frac{n\pi}{L}x dx}{\int_0^L \sin^2 \frac{n\pi}{L}x dx} \quad (\text{note } \sigma \equiv 1). \quad (6.1.19)$$

The Rayleigh quotient in this case is

$$\lambda = \frac{-X(x)X'(x)|_0^L + \int_0^L [X'(x)]^2 dx}{\int_0^L X^2(x) dx} = \frac{\int_0^L [X'(x)]^2 dx}{\int_0^L X^2(x) dx}. \quad (6.1.20)$$

This does NOT determine  $\lambda$ , but one can see that  $\lambda > 0$  (Exercise).

Example      nonuniform rod

$$c(x)\rho(x)u_t = (K(x)u_x)_x, \quad (6.1.21)$$

$$u(0, t) = u_x(L, t) = 0, \quad (6.1.22)$$

$$u(x, 0) = f(x). \quad (6.1.23)$$

The method of separation of variables yields two ODE's

$$\dot{T}(t) + \lambda T(t) = 0, \quad (6.1.24)$$

$$(K(x)X'(x))' + \lambda c(x)\rho(x)X(x) = 0, \quad (6.1.25)$$

$$X(0) = 0, \quad (6.1.26)$$

$$X'(L) = 0. \quad (6.1.27)$$

We cannot obtain the eigenvalues and eigenfunctions but we know from the last theorem that the solution is

$$u(x, t) = \sum_{n=1}^{\infty} T_n(0)e^{-\lambda_n t} X_n(x) \quad (6.1.28)$$

where

$$T_n(0) = \frac{\int_0^L f(x)X_n(x)c(x)\rho(x)dx}{\int_0^L X_n^2(x)c(x)\rho(x)dx}. \quad (6.1.29)$$

(The details are left for the reader.)

What happens for  $t$  large (the system will approach a steady state) can be found by examining (6.1.28). Since  $\lambda_n \rightarrow \infty$  as  $n \rightarrow \infty$ , the solution will be

$$u(x, t) \approx T_1(0)e^{-\lambda_1 t} X_1(x) \quad (\text{if } T_1(0) \neq 0), \quad (6.1.30)$$

since other terms will be smaller because of the decaying exponential factor. Therefore the first eigenpair  $\lambda_1, X_1(x)$  is sufficient for the steady state. This eigenpair can be found by approximation of the Rayleigh quotient.

Definition 20. A Sturm-Liouville problem is called singular if either one of the following conditions occurs :

- i. The function  $p(x)$  vanishes at one or both of the endpoints.
- ii. One or more of the coefficients  $p(x)$ ,  $q(x)$ , or  $\sigma(x)$  becomes infinite at either of the endpoints.
- iii. One of the endpoints is infinite.

### Example

The circularly symmetric heat flow problem

$$\frac{d}{dr} \left( r \frac{dR}{dr} \right) + \lambda r R(r) = 0, \quad 0 < r < a,$$

leads to a singular Sturm-Liouville problem since  $p(r) = r$  vanishes at  $r = 0$ .

## Problems

1. a. Show that the following is a regular Sturm-Liouville problem

$$X''(x) + \lambda X(x) = 0,$$

$$X(0) = 0,$$

$$X'(L) = 0.$$

- b. Find the eigenpairs  $\lambda_n, X_n$  directly.  
c. Show that these pairs satisfy the results of the theorem.

2. Prove (6.1.28) - (6.1.30).

3. a. Is the following a regular Sturm-Liouville problem?

$$X''(x) + \lambda X(x) = 0,$$

$$X(0) = X(L),$$

$$X'(0) = X'(L).$$

Why or why not?

- b. Find the eigenpairs  $\lambda_n, X_n$  directly.  
c. Do they satisfy the results of the theorem? Why or why not?
4. Solve the regular Sturm-Liouville problem

$$X''(x) + aX(x) + \lambda X(x) = 0, \quad a > 0,$$

$$X(0) = X(L) = 0.$$

For what range of values of  $a$  is  $\lambda$  negative?

5. Solve the ODE

$$X''(x) + 2\alpha X(x) + \lambda X(x) = 0, \quad \alpha > 1,$$

$$X(0) = X'(1) = 0.$$

6. Consider the following Sturm-Liouville eigenvalue problem

$$\frac{d}{dx} \left( x \frac{du}{dx} \right) + \lambda \frac{1}{x} u = 0, \quad 1 < x < 2,$$

with boundary conditions

$$u(1) = u(2) = 0.$$

Determine the sign of all the eigenvalues of this problem (you don't have to explicitly determine the eigenvalues). In particular, is zero an eigenvalue of this problem?

7. Consider the following model approximating the motion of a string whose density (along the string) is proportional to  $(1+x)^{-2}$ ,

$$(1+x)^{-2}u_{tt} - u_{xx} = 0, \quad 0 < x < 1, \quad t > 0$$

subject to the following initial conditions

$$u(x, 0) = f(x),$$

$$u_t(x, 0) = 0,$$

and boundary conditions

$$u(0, t) = u(L, t) = 0.$$

a. Show that the ODE for  $X$  resulting from separation of variables is

$$X'' + \frac{\lambda}{(1+x)^2}X = 0.$$

b. Obtain the boundary conditions and solve.

Hint: Try  $X = (1+x)^a$ .

## 6.2 Boundary Conditions of the Third Kind

In this section we discuss the solution of a regular Sturm-Liouville problem having a more general type of boundary conditions. We will show that even though the coefficients are constant, we cannot give the eigenvalues in closed form.

### Example

Suppose we want to find the temperature distribution in a rod of length  $L$  where the right end is allowed to cool down, i.e.

$$u_t = ku_{xx} \quad 0 < x < L, \quad (6.2.1)$$

$$u(0, t) = 0, \quad (6.2.2)$$

$$u_x(L, t) = -hu(L, t), \quad (6.2.3)$$

$$u(x, 0) = f(x),$$

where  $h$  is a positive constant.

The Sturm-Liouville problem is (see exercise)

$$X'' + \lambda X = 0, \quad (6.2.4)$$

$$X(0) = 0, \quad (6.2.5)$$

$$X'(L) = -hX(L). \quad (6.2.6)$$

We consider these three cases for  $\lambda$ . (If we prove that the operator is self-adjoint, then we get that the eigenvalues must be real.)

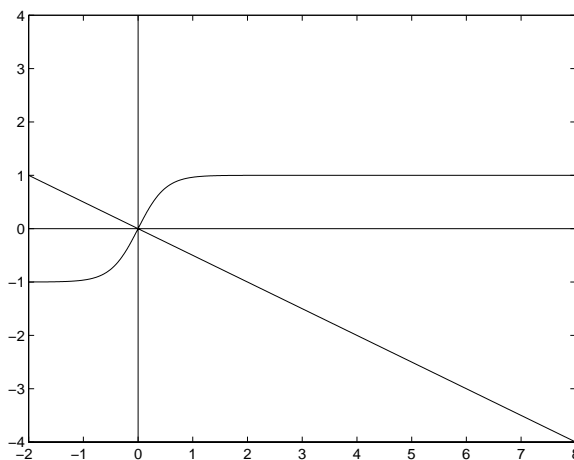

Figure 47: Graphs of both sides of the equation in case 1

### Case 1: $\lambda < 0$

The solution that satisfies (6.2.5) is

$$X = A \sinh \sqrt{-\lambda}x. \quad (6.2.7)$$



To satisfy (6.2.6) we have

$$A\sqrt{-\lambda} \cosh \sqrt{-\lambda}L = -hA \sinh \sqrt{-\lambda}L,$$

or

$$\tanh \sqrt{-\lambda}L = -\frac{1}{hL}\sqrt{-\lambda}L. \quad (6.2.8)$$

This equation for the eigenvalues can be solved either numerically or graphically. If we sketch  $\tanh \sqrt{-\lambda}L$  and  $-\frac{1}{hL}\sqrt{-\lambda}L$  as functions of  $\sqrt{-\lambda}L$  then, since  $h > 0$ , we have only one point of intersection, i.e.  $\sqrt{-\lambda}L = 0$ . Since  $L > 0$  (length) and  $\lambda < 0$  (assumed in this case), this point is not in the domain under consideration. Therefore  $\lambda < 0$  yields a trivial solution.

Case 2:  $\lambda = 0$

In this case the solution satisfying (6.2.5) is

$$X = Bx. \quad (6.2.9)$$

Using the boundary condition at  $L$ , we have

$$B(1 + hL) = 0, \quad (6.2.10)$$

Since  $L > 0$  and  $h > 0$ , the only possibility is again the trivial solution.

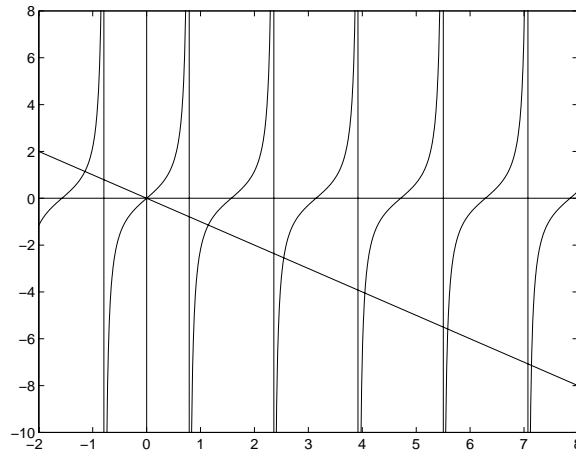

Figure 48: Graphs of both sides of the equation in case 3

Case 3:  $\lambda > 0$

The solution is

$$X = A \sin \sqrt{\lambda}x, \quad (6.2.11)$$

and the equation for the eigenvalues  $\lambda$  is

$$\tan \sqrt{\lambda}L = -\frac{\sqrt{\lambda}}{h} \quad (6.2.12)$$

(see exercise).

Graphically, we see an infinite number of solutions, all eigenvalues are positive and the reader should show that

$$\lambda_n \rightarrow \left[ \frac{(n - \frac{1}{2})\pi}{L} \right]^2 \quad \text{as } n \rightarrow \infty.$$

## Problems

1. Use the method of separation of variables to obtain the ODE's for  $x$  and for  $t$  for equations (6.2.1) - (6.2.3).
2. Give the details for the case  $\lambda > 0$  in solving (6.2.4) - (6.2.6).
3. Discuss

$$\lim_{n \rightarrow \infty} \lambda_n$$

for the above problem.

4. Write the Rayleigh quotient for (6.2.4) - (6.2.6) and show that the eigenvalues are all positive. (That means we should have considered only case 3.)
5. What if  $h < 0$  in (6.2.3)? Is there an  $h$  for which  $\lambda = 0$  is an eigenvalue of this problem?

### 6.3 Proof of Theorem and Generalizations

In this section, we prove the theorem for regular Sturm-Liouville problems and discuss some generalizations. Before we get into the proof, we collect several auxiliary results.

Let  $\mathcal{L}$  be the linear differential operator

$$\mathcal{L}u = \frac{d}{dx} \left[ p(x) \frac{du}{dx} \right] + q(x)u. \quad (6.3.1)$$

Therefore the Sturm-Liouville differential equation (6.1.8) can be written as

$$\mathcal{L}X + \lambda\sigma X = 0. \quad (6.3.2)$$

Lemma For any two differentiable functions  $u(x)$ ,  $v(x)$  we have

$$u\mathcal{L}v - v\mathcal{L}u = \frac{d}{dx} \left[ p(x) \left( u \frac{dv}{dx} - v \frac{du}{dx} \right) \right]. \quad (6.3.3)$$

This is called Lagrange's identity.

Proof:

By (6.3.1)

$$\mathcal{L}u = (pu')' + qu,$$

$$\mathcal{L}v = (pv')' + qv,$$

therefore

$$u\mathcal{L}v - v\mathcal{L}u = u(pv')' + uqv - v(pu')' - vqu,$$

since the terms with  $q$  cancel out, we have

$$\begin{aligned} &= \frac{d}{dx} (pv'u) - u'pv' - \left[ \frac{d}{dx} (pu'v) - pu'v' \right] \\ &= \frac{d}{dx} [p(v'u - u'v)]. \end{aligned}$$

Lemma For any two differentiable functions  $u(x)$ ,  $v(x)$  we have

$$\int_a^b [u\mathcal{L}v - v\mathcal{L}u] dx = p(x) (uv' - vu') \Big|_a^b. \quad (6.3.4)$$

This is called Green's formula.

Definition 21. A differential operator  $\mathcal{L}$  defined by (6.3.1) is called self-adjoint if

$$\int_a^b (u\mathcal{L}v - v\mathcal{L}u) dx = 0 \quad (6.3.5)$$

for any two differentiable functions satisfying the boundary conditions (6.1.9)-(6.1.10).

Remark: It is easy to show and is left for the reader that the boundary conditions (6.1.9)-(6.1.10) ensure that the right hand side of (6.3.4) vanishes.

We are now ready to prove the theorem and we start with the proof that the eigenfunctions are orthogonal.

Let  $\lambda_n, \lambda_m$  be two distinct eigenvalues with corresponding eigenfunctions  $X_n, X_m$ , that is

$$\begin{aligned}\mathcal{L}X_n + \lambda_n\sigma X_n &= 0, \\ \mathcal{L}X_m + \lambda_m\sigma X_m &= 0.\end{aligned}\tag{6.3.6}$$

In addition, the eigenfunctions satisfy the boundary conditions. Using Green's formula we have

$$\int_a^b (X_m\mathcal{L}X_n - X_n\mathcal{L}X_m) dx = 0.$$

Now use (6.3.6) to get

$$(\lambda_n - \lambda_m) \int_a^b X_n X_m \sigma dx = 0$$

and since  $\lambda_n \neq \lambda_m$  we must have

$$\int_a^b X_n X_m \sigma dx = 0$$

which means that (see definition 14)  $X_n, X_m$  are orthogonal with respect to the weight  $\sigma$  on the interval  $(a, b)$ .

This result will help us prove that the eigenvalues are real.

Suppose that  $\lambda$  is a complex eigenvalue with eigenfunction  $X(x)$ , i.e.

$$\mathcal{L}X + \lambda\sigma X = 0.\tag{6.3.7}$$

If we take the complex conjugate of the equation (6.3.7) we have (since all the coefficients of the differential equation are real)

$$\mathcal{L}\bar{X} + \bar{\lambda}\sigma\bar{X} = 0.\tag{6.3.8}$$

The boundary conditions for  $X$  are

$$\beta_1 X(a) + \beta_2 X'(a) = 0,$$

$$\beta_3 X(b) + \beta_4 X'(b) = 0.$$

Taking the complex conjugate and recalling that all  $\beta_i$  are real, we have

$$\beta_1 \bar{X}(a) + \beta_2 \bar{X}'(a) = 0,$$

$$\beta_3 \bar{X}(b) + \beta_4 \bar{X}'(b) = 0.$$

Therefore  $\bar{X}$  satisfies the same regular Sturm-Liouville problem. Now using Green's formula (6.3.4) with  $u = X$  and  $v = \bar{X}$ , and the boundary conditions for  $X, \bar{X}$ , we get

$$\int_a^b (X\mathcal{L}\bar{X} - \bar{X}\mathcal{L}X) dx = 0.\tag{6.3.9}$$

But upon using the differential equations (6.3.7)-(6.3.8) in (6.3.9) we have

$$(\lambda - \bar{\lambda}) \int_a^b \sigma X \bar{X} dx = 0.$$

Since  $X$  is an eigenfunction then  $X$  is not zero and  $X\bar{X} = |X|^2 > 0$ . Therefore the integral is positive ( $\sigma > 0$ ) and thus  $\lambda = \bar{\lambda}$  and hence  $\lambda$  is real. Since  $\lambda$  is an arbitrary eigenvalue, then all eigenvalues are real.

We now prove that each eigenvalue has a unique (up to a multiplicative constant) eigenfunction.

Suppose there are two eigenfunctions  $X_1, X_2$  corresponding to the same eigenvalue  $\lambda$ , then

$$\mathcal{L}X_1 + \lambda\sigma X_1 = 0, \quad (6.3.10)$$

$$\mathcal{L}X_2 + \lambda\sigma X_2 = 0. \quad (6.3.11)$$

Multiply (6.3.10) by  $X_2$  and (6.3.11) by  $X_1$  and subtract, then

$$X_2\mathcal{L}X_1 - X_1\mathcal{L}X_2 = 0, \quad (6.3.12)$$

since  $\lambda$  is the same for both equations. On the other hand, the left hand side, by Lagrange's identity (6.3.3) is

$$X_2\mathcal{L}X_1 - X_1\mathcal{L}X_2 = \frac{d}{dx} [p(X_2X_1' - X_1X_2')]. \quad (6.3.13)$$

Combining the two equations, we get after integration that

$$p(X_2X_1' - X_1X_2') = \text{constant}. \quad (6.3.14)$$

It can be shown that the constant is zero for any two eigenfunctions of the regular Sturm-Liouville problem (see exercise). Dividing by  $p$ , we have

$$X_2X_1' - X_1X_2' = 0. \quad (6.3.15)$$

The left hand side is

$$\frac{d}{dx} \left( \frac{X_1}{X_2} \right),$$

therefore

$$\frac{X_1}{X_2} = \text{constant}$$

which means that  $X_1$  is a multiple of  $X_2$  and thus they are the same eigenfunction (up to a multiplicative constant).

The proof that the eigenfunctions form a complete set can be found, for example, in Coddington and Levinson (1955). The convergence in the mean of the expansion is based on Bessel's inequality

$$\sum_{n=0}^{\infty} \left( \int_a^b f(x) X_n(x) \sigma(x) dx \right)^2 \leq \|f\|^2 \quad (6.3.16)$$

Completeness amounts to the absence of nontrivial functions orthogonal to all of the  $X_n$ . In other words, for a complete set  $\{X_n\}$ , if the inner product of  $f$  with each  $X_n$  is zero and if  $f$  is continuous then  $f$  vanishes identically.

The proof of existence of an infinite number of eigenvalues is based on comparison theorems, see e.g. Cochran (1982), and will not be given here.

The Rayleigh quotient can be derived from (6.1.8) by multiplying through by  $X$  and integrating over the interval  $(a, b)$

$$\int_a^b \left[ X \frac{d}{dx} (pX') + qX^2 \right] dx + \lambda \int_a^b X^2 \sigma dx = 0. \quad (6.3.17)$$

Since the last integral is positive ( $X$  is an eigenfunction and  $\sigma > 0$ ) we get after division by it

$$\lambda = \frac{-\int_a^b X (pX')' dx - \int_a^b qX^2 dx}{\int_a^b \sigma X^2 dx}. \quad (6.3.18)$$

Use integration by parts for the first integral in the numerator to get

$$\lambda = \frac{\int_a^b p (X')^2 dx - \int_a^b qX^2 dx - pXX'|_a^b}{\int_a^b \sigma X^2 dx},$$

which is Rayleigh quotient.

Remarks:

1. If  $q \leq 0$  and  $pXX'|_a^b \leq 0$  then Rayleigh quotient proves that  $\lambda \geq 0$ .

2. Rayleigh quotient cannot be used to find the eigenvalues but it yields an estimate of the smallest eigenvalue. In fact, we can find other eigenvalues using optimization techniques.

We now prove that any second order differential equation whose highest order coefficient is positive can be put into the self adjoint form and thus we can apply the theorem we proved here concerning the eigenpairs.

Lemma: Any second order differential equation whose highest order coefficient is positive can be put into the self adjoint form by a simple multiplication of the equation.

Proof:

Given the equation

$$a(x)u''(x) + b(x)u'(x) + c(x)u(x) + \lambda d(x)u(x) = 0, \quad \alpha < x < \beta$$

with

$$a(x) > 0,$$

then by multiplying the equation by

$$\frac{1}{a(x)} e^{\int_{\alpha}^x b(\xi)/a(\xi) d\xi}$$

we have

$$u''(x)e^{\int_{\alpha}^x b(\xi)/a(\xi)d\xi} + \frac{b(x)}{a(x)}u'(x)e^{\int_{\alpha}^x b(\xi)/a(\xi)d\xi} + \frac{c(x)}{a(x)}u(x)e^{\int_{\alpha}^x b(\xi)/a(\xi)d\xi} + \lambda \frac{d(x)}{a(x)}e^{\int_{\alpha}^x b(\xi)/a(\xi)d\xi} = 0.$$

The first two terms can be combined

$$\frac{d}{dx} \left[ u'(x)e^{\int_{\alpha}^x b(\xi)/a(\xi)d\xi} \right]$$

and thus upon comparison with (6.1.8) we see that

$$p(x) = e^{\int_{\alpha}^x b(\xi)/a(\xi)d\xi},$$

$$q(x) = \frac{c(x)}{a(x)}p(x),$$

and

$$\sigma = \frac{d(x)}{a(x)}p(x).$$

Remark: For periodic boundary conditions, the constant in (6.3.14) is not necessarily zero and one may have more than one eigenfunction for the same eigenvalue. In fact, we have seen in Chapter 4 that if the boundary conditions are periodic the eigenvalues are

$$\lambda_n = \left( \frac{2n\pi}{L} \right)^2, \quad n = 0, 1, 2, \dots$$

and the eigenfunctions for  $n > 0$  are

$$X_n(x) = \begin{cases} \cos \frac{2n\pi}{L}x & n = 1, 2, \dots \\ \sin \frac{2n\pi}{L}x & n = 1, 2, \dots \end{cases}$$

However these two eigenfunctions are orthogonal as we have shown in Chapter 5. If in some case, the eigenfunctions belonging to the same eigenvalue are not orthogonal, we can use Gram-Schmidt orthogonalization process (similar to that discussed in Linear Algebra).



## Problems

1. Show that if  $u, v$  both satisfy the boundary conditions (6.1.9)-(6.1.10) then

$$p(uv' - vu') \Big|_a^b = 0.$$

2. Show that the right hand side of (6.3.4) is zero even if  $u, v$  satisfy periodic boundary conditions, i.e.

$$\begin{aligned}u(a) &= u(b) \\ p(a)u'(a) &= p(b)u'(b),\end{aligned}$$

and similarly for  $v$ .

3. What can be proved about eigenvalues and eigenfunctions of the circularly symmetric heat flow problem.

Give details of the proof.

Note: This is a singular Sturm-Liouville problem.

4. Consider the heat flow with convection

$$u_t = ku_{xx} + V_0 u_x, \quad 0 < x < L, \quad t > 0.$$

- Show that the spatial ordinary differential equation obtained by separation of variables is not in Sturm-Liouville form.
- How can it be reduced to S-L form?
- Solve the initial boundary value problem

$$u(0, t) = 0, \quad t > 0,$$

$$u(L, t) = 0, \quad t > 0,$$

$$u(x, 0) = f(x), \quad 0 < x < L.$$

## 6.4 Linearized Shallow Water Equations

In this section, we give an example of an eigenproblem where the eigenvalues appear also in the boundary conditions. We show how to find all eigenvalues in such a case. The eigenfunctions relate to the confluent hypergeometric functions.

The shallow water equations are frequently used in simplified dynamical studies of atmospheric and oceanographic phenomena. When the equations are linearized, the thickness of the fluid is often assumed to be a linear function of one of the spatial variables, see Staniforth, Williams and Neta [1993]. The basic equations are derived in Pedlosky [1979]. The thickness of the fluid layer is given by

$$H(x, y, t) = H_0(y) + \eta(x, y, t) \quad (6.4.1)$$

where

$$|\eta| \ll H.$$

If  $u, v$  are small velocity perturbations, the equations of motion become

$$\frac{\partial u}{\partial t} - fv = -g \frac{\partial \eta}{\partial x} \quad (6.4.2)$$

$$\frac{\partial v}{\partial t} + fu = -g \frac{\partial \eta}{\partial y} \quad (6.4.3)$$

$$\frac{\partial \eta}{\partial t} + H_0 \frac{\partial u}{\partial x} + \frac{\partial}{\partial y} (vH_0) = 0 \quad (6.4.4)$$

where  $f$  is the Coriolis parameter and  $g$  is the acceleration of gravity. We assume periodic boundary conditions in  $x$  and wall conditions in  $y$  where the walls are at  $\pm L/2$ . We also let

$$H_0 = D_0 \left(1 - \frac{s}{L}y\right)$$

with  $D_0$  the value at  $y = 0$  and  $s$  is a parameter not necessarily small as long as  $H_0$  is positive in the domain.

It was shown by Staniforth et al [1993] that the eigenproblem is given by

$$-\frac{d}{dy} \left[ \left(1 - \frac{s}{L}y\right) \frac{d\phi}{dy} \right] + k^2 \left(1 - \frac{s}{L}y\right) \phi - \lambda(c)\phi = 0 \quad (6.4.5)$$

$$\frac{d\phi}{dy} + \frac{1}{c}f\phi = 0 \quad \text{on} \quad y = \pm \frac{L}{2} \quad (6.4.6)$$

where

$$\lambda(c) = \frac{k^2 c^2 - f^2}{gD_0} - \frac{fs}{Lc} \quad (6.4.7)$$

and  $k$  is the  $x$ -wave number.

Using the transformation

$$z = 2k \left( \frac{L}{s} - y \right), \quad (6.4.8)$$

the eigenvalue problem becomes

$$\frac{d}{dz} \left( z \frac{d\phi}{dz} \right) - \left( \frac{z}{4} - \frac{\lambda(c)L}{2sk} \right) \phi = 0, \quad z_- < z < z_+ \quad (6.4.9)$$

$$\frac{d\phi}{dz} - \frac{1}{c} \frac{f}{2k} \phi = 0, \quad z = z_{\pm}, \quad (6.4.10)$$

where

$$z_{\pm} = \frac{2kL}{s} \left( 1 \mp \frac{s}{2} \right). \quad (6.4.11)$$

Notice that the eigenvalues  $\lambda(c)$  appear nonlinearly in the equation and in the boundary conditions.

Another transformation is necessary to get a familiar ODE, namely

$$\phi = e^{-z/2} \psi. \quad (6.4.12)$$

Thus we get Kummer's equation (see e.g. Abramowitz and Stegun, 1965)

$$z\psi'' + (1-z)\psi' - a(c)\psi = 0 \quad (6.4.13)$$

$$\psi'(z_{\pm}) - \frac{1}{2} \left( 1 + \frac{1}{c} \frac{f}{k} \right) \psi(z_{\pm}) = 0 \quad (6.4.14)$$

where

$$a(c) = \frac{1}{2} - \frac{\lambda(c)L}{2sk}. \quad (6.4.15)$$

The general solution is a combination of the confluent hypergeometric functions  $M(a, 1; z)$  and  $U(a, 1; z)$  if  $a(c)$  is not a negative integer. For a negative integer,  $a(c) = -n$ , the solution is  $L_n(z)$ , the Laguerre polynomial of degree  $n$ . We leave it as an exercise for the reader to find the second solution in the case  $a(c) = -n$ .

## Problems

1. Find the second solution of (6.4.13) for  $a(c) = -n$ .

Hint: Use the power series solution method.

2.

a. Find a relationship between  $M(a, b; z)$  and its derivative  $\frac{dM}{dz}$ .

b. Same for  $U$ .

3. Find in the literature a stable recurrence relation to compute the confluent hypergeometric functions.

## 6.5 Eigenvalues of Perturbed Problems

In this section, we show how to solve some problems which are slightly perturbed. The first example is the solution of Laplace's equation outside a near sphere, i.e. the boundary is perturbed slightly.

Example Find the potential outside the domain

$$r = 1 + \epsilon P_2(\cos \theta) \quad (6.5.1)$$

where  $P_2$  is a Legendre polynomial of degree 2 and  $\epsilon$  is a small parameter. Clearly when  $\epsilon = 0$  the domain is a sphere of radius 1.

The statement of the problem is

$$\nabla^2 \phi = 0 \quad \text{in} \quad r \geq 1 + \epsilon P_2(\cos \theta) \quad (6.5.2)$$

subject to the boundary condition

$$\phi = 1 \quad \text{on} \quad r = 1 + \epsilon P_2(\cos \theta) \quad (6.5.3)$$

and the boundedness condition

$$\phi \rightarrow 0 \quad \text{as} \quad r \rightarrow \infty. \quad (6.5.4)$$

Suppose we expand the potential  $\phi$  in powers of  $\epsilon$ ,

$$\phi(r, \theta, \epsilon) = \phi_0(r, \theta) + \epsilon \phi_1(r, \theta) + \epsilon^2 \phi_2(r, \theta) + \dots \quad (6.5.5)$$

then we expect  $\phi_0$  to be the solution of the unperturbed problem, i.e.  $\phi_0 = \frac{1}{r}$ . This will be shown in this example. Substituting the approximation (6.5.5) into (6.5.2) and (6.5.4), and then comparing the coefficients of  $\epsilon^n$ , we find that

$$\nabla^2 \phi_n = 0 \quad (6.5.6)$$

$$\phi_n \rightarrow 0 \quad \text{as} \quad r \rightarrow \infty. \quad (6.5.7)$$

The last condition (6.5.3) can be checked by using Taylor series

$$1 = \phi|_{r=1+\epsilon P_2(\cos \theta)} = \sum_{n=0}^{\infty} \frac{(\epsilon P_2)^n}{n!} \frac{\partial^n \phi}{\partial r^n} \Big|_{r=1}. \quad (6.5.8)$$

Now substituting (6.5.5) into (6.5.8) and collect terms of the same order to have

$$\begin{aligned} 1 = \phi_0(1, \theta) &+ \epsilon \left[ \phi_1(1, \theta) + P_2(\cos \theta) \frac{\partial \phi_0(1, \theta)}{\partial r} \right] \\ &+ \epsilon^2 \left[ \phi_2(1, \theta) + P_2(\cos \theta) \frac{\partial \phi_1(1, \theta)}{\partial r} + \frac{1}{2} P_2^2(\cos \theta) \frac{\partial^2 \phi_0(1, \theta)}{\partial r^2} \right] \\ &+ \dots \end{aligned}$$

Thus the boundary conditions are

$$\phi_0(1, \theta) = 1 \quad (6.5.9)$$

$$\phi_1(1, \theta) = -P_2(\cos \theta) \frac{\partial \phi_0(1, \theta)}{\partial r} \quad (6.5.10)$$

$$\phi_2(1, \theta) = -P_2(\cos \theta) \frac{\partial \phi_1(1, \theta)}{\partial r} - \frac{1}{2} P_2^2(\cos \theta) \frac{\partial^2 \phi_0(1, \theta)}{\partial r^2} \quad (6.5.11)$$

The solution of (6.5.6)-(6.5.7) for  $n = 0$  subject to the boundary condition (6.5.9) is then

$$\phi_0(r, \theta) = \frac{1}{r} \quad (6.5.12)$$

as mentioned earlier. Now substitute the solution (6.5.12) in (6.5.10) to get

$$\phi_1(1, \theta) = P_2(\cos \theta) \frac{1}{r^2} \Big|_{r=1} = P_2(\cos \theta) \quad (6.5.13)$$

Now solve (6.5.6)-(6.5.7) for  $n = 1$  subject to the boundary condition (6.5.13) to get

$$\phi_1(r, \theta) = \frac{P_2(\cos \theta)}{r^3}. \quad (6.5.14)$$

Using these  $\phi_0, \phi_1$  in (6.5.11), we get the boundary condition for  $\phi_2$

$$\phi_2(1, \theta) = 2P_2^2(\cos \theta) = \frac{36}{35} P_4(\cos \theta) + \frac{4}{7} P_2(\cos \theta) + \frac{2}{5} P_0(\cos \theta) \quad (6.5.15)$$

and one can show that the solution of (6.5.6)-(6.5.7) for  $n = 2$  subject to the boundary condition (6.5.15) is

$$\phi_2(r, \theta) = \frac{36}{35} \frac{P_4(\cos \theta)}{r^5} + \frac{4}{7} \frac{P_2(\cos \theta)}{r^3} + \frac{2}{5} \frac{1}{r}. \quad (6.5.16)$$

Thus

$$\phi(r, \theta) = \frac{1}{r} + \epsilon \frac{P_2(\cos \theta)}{r^3} + \epsilon^2 \left\{ \frac{36}{35} \frac{P_4(\cos \theta)}{r^5} + \frac{4}{7} \frac{P_2(\cos \theta)}{r^3} + \frac{2}{5} \frac{1}{r} \right\} + \dots \quad (6.5.17)$$

The next example is a perturbed equation but no perturbation in the boundary.

Example Consider a near uniform flow with a parabolic perturbation, i.e.

$$u = 1 + \epsilon y^2 \quad \text{at infinity.} \quad (6.5.18)$$

In steady, inertially dominated inviscid flow the vorticity  $\zeta$  is constant along a streamline. Thus the streamfunction  $\psi(x, y, \epsilon)$  satisfies

$$\nabla^2 \psi = -\zeta(\psi, \epsilon) \quad \text{in } r > 1, \quad (6.5.19)$$

subject to the boundary conditions

$$\psi = 0, \quad \text{on } r = 1, \quad (6.5.20)$$

and

$$\psi \rightarrow y + \frac{1}{3}\epsilon y^3 \quad \text{as } r \rightarrow \infty. \quad (6.5.21)$$

To find  $\zeta$ , we note that in the far field

$$\psi = y + \frac{1}{3}\epsilon y^3 \quad (6.5.22)$$

and thus

$$\zeta = -\nabla^2\psi = -2\epsilon y, \quad (6.5.23)$$

or in terms of  $\psi$

$$\zeta = -2\epsilon\psi + \frac{2}{3}\epsilon^2\psi^3 + \dots \quad (6.5.24)$$

Now we suppose the streamfunction is given by the Taylor series

$$\psi = \psi_0(r, \theta) + \epsilon\psi_1(r, \theta) + \dots \quad (6.5.25)$$

Substitute (6.5.25) and (6.5.24) in (6.5.19)-(6.5.20) we have upon comparing terms with no  $\epsilon$ :

$$\begin{aligned} \nabla^2\psi_0 &= 0 & \text{in } r > 1, \\ \psi_0 &= 0 & \text{on } r = 1, \\ \psi_0 &\rightarrow r \sin \theta & \text{as } r \rightarrow \infty \end{aligned}$$

which has a solution

$$\psi_0 = \sin \theta \left( r - \frac{1}{r} \right). \quad (6.5.26)$$

Using (6.5.26) in the terms with  $\epsilon^1$  we have

$$\begin{aligned} \nabla^2\psi_1 &= 2 \sin \theta \left( r - \frac{1}{r} \right) & \text{in } r > 1, \\ \psi_1 &= 0 & \text{on } r = 1, \\ \psi_1 &\rightarrow \frac{1}{3}r^3 \sin^3 \theta & \text{as } r \rightarrow \infty \end{aligned}$$

The solution is (see Hinch [1991])

$$\psi_1 = \frac{1}{3}r^3 \sin^3 \theta - r \ln r \sin \theta - \frac{1}{4} \frac{\sin \theta}{r} + \frac{1}{12} \frac{\sin 3\theta}{r^3}. \quad (6.5.27)$$

The last example is of finding the eigenvalues and eigenfunctions of a perturbed second order ODE.

Example Find the eigenvalues and eigenfunctions of the perturbed Sturm Liouville problem

$$X''(x) + (\lambda + \epsilon\Lambda(x)) X(x) = 0, \quad 0 < x < 1 \quad (6.5.28)$$

subject to the boundary conditions

$$X(0) = X(1) = 0. \quad (6.5.29)$$

Assume a perturbation for the  $n^{\text{th}}$  eigenpair

$$\lambda_n = \lambda_n^{(0)} + \epsilon\lambda_n^{(1)} + \epsilon^2\lambda_n^{(2)} + \dots \quad (6.5.30)$$

$$X_n = X_n^{(0)} + \epsilon X_n^{(1)} + \epsilon^2 X_n^{(2)} + \dots \quad (6.5.31)$$

Substituting these expansions in (6.5.28) and comparing terms with like powers of  $\epsilon$ . For the zeroth power we have

$$X_n^{(0)''} + \lambda_n^{(0)} X_n^{(0)} = 0$$

$$X_n^{(0)}(0) = X_n^{(0)}(1) = 0,$$

which has the unperturbed solution

$$\lambda_n^{(0)} = (n\pi)^2, \quad (6.5.32)$$

$$X_n^{(0)} = \sin n\pi x. \quad (6.5.33)$$

For the linear power of  $\epsilon$ , we have

$$X_n^{(1)''} + (n\pi)^2 X_n^{(1)} = -(\Lambda(x) + \lambda_n^{(1)}) \sin n\pi x, \quad (6.5.34)$$

$$X_n^{(1)}(0) = X_n^{(1)}(1) = 0. \quad (6.5.35)$$

The inhomogeneous ODE (6.5.34) can be solved by the method of eigenfunction expansion (see Chapter 8). Let

$$X_n^{(1)} = \sum_{m=1}^{\infty} \alpha_m \sin m\pi x, \quad (6.5.36)$$

and

$$-(\Lambda(x) + \lambda_n^{(1)}) \sin n\pi x = \sum_{m=1}^{\infty} \Lambda_m \sin m\pi x, \quad (6.5.37)$$

where

$$\Lambda_m = -2 \int_0^1 \Lambda(x) \sin n\pi x \sin m\pi x dx - \lambda_n^{(1)} \delta_{nm}. \quad (6.5.38)$$

Substituting (6.5.36) into (6.5.34) we get

$$\sum_{m=1}^{\infty} \{-(m\pi)^2 + (n\pi)^2\} \alpha_m \sin m\pi x = \sum_{m=1}^{\infty} \Lambda_m \sin m\pi x. \quad (6.5.39)$$

Thus

$$\alpha_m = \frac{\Lambda_m}{-(m\pi)^2 + (n\pi)^2}, \quad m \neq n. \quad (6.5.40)$$



To find  $\lambda_n^{(1)}$ , we multiply (6.5.39) by  $\sin n\pi x$  and integrate on the interval  $(0,1)$ . Thus the linear order approximation to  $\lambda_n$  is given by

$$\lambda_n^{(1)} = -2 \int_0^1 \Lambda(x) \sin^2 n\pi x dx. \quad (6.5.41)$$

The linear order approximation to  $X_n$  is given by (6.5.36) with the coefficients  $\alpha_m$  given by (6.5.40). What happens for  $n = m$  is left for the reader.

## Problems

1. The flow down a slightly corrugated channel is given by  $u(x, y, \epsilon)$  which satisfies

$$\nabla^2 u = -1 \quad \text{in } |y| \leq h(x, \epsilon) = 1 + \epsilon \cos kx$$

subject to

$$u = 0 \quad \text{on } y = \pm h(x, \epsilon)$$

and periodic boundary conditions in  $x$ .

Obtain the first two terms for  $u$ .

2. The functions  $\phi(x, y, \epsilon)$  and  $\lambda(\epsilon)$  satisfy the eigenvalue problem

$$\phi_{xx} + \phi_{yy} + \lambda\phi = 0 \quad \text{in } 0 \leq x \leq \pi, \quad 0 + \epsilon x(\pi - x) \leq y \leq \pi$$

subject to

$$\phi = 0 \quad \text{on the boundary.}$$

Find the first order correction to the eigenpair

$$\phi_1^{(0)} = \sin x \sin y$$

$$\lambda_1^{(0)} = 2$$

## SUMMARY

Theorem For a regular Sturm-Liouville problem

$$\frac{d}{dx} \left( p(x) \frac{dX(x)}{dx} \right) + q(x)X(x) + \lambda\sigma(x)X(x) = 0, \quad a < x < b.$$

$$\beta_1 X(a) + \beta_2 X'(a) = 0,$$

$$\beta_3 X(b) + \beta_4 X'(b) = 0,$$

the following is true

- i. All the eigenvalues  $\lambda$  are real
- ii. There exist an infinite number of eigenvalues

$$\lambda_1 < \lambda_2 < \dots < \lambda_n < \dots$$

- a. there is a smallest eigenvalue denoted by  $\lambda_1$
- b.  $\lambda_n \rightarrow \infty$  as  $n \rightarrow \infty$
- iii. Corresponding to each  $\lambda_n$  there is an eigenfunction  $X_n$  (unique up to an arbitrary multiplicative constant).  $X_n$  has exactly  $n - 1$  zeros in the open interval  $(a, b)$ .
- iv. The eigenfunctions form a complete set, i.e. any smooth function  $f(x)$  can be represented as

$$f(x) \sim \sum_{n=1}^{\infty} a_n X_n(x).$$

$$a_n = \frac{\int_a^b f(x) X_n(x) \sigma(x) dx}{\int_a^b X_n^2(x) \sigma(x) dx}$$

This infinite series, called generalized Fourier series, converges to  $\frac{f(x_+) + f(x_-)}{2}$  if  $a_n$  are properly chosen.

- v. Eigenfunctions belonging to different eigenvalues are orthogonal relative to the weight  $\sigma$ , i.e.

$$\int_a^b \sigma(x) X_n(x) X_m(x) dx = 0, \quad \text{if } \lambda_n \neq \lambda_m.$$

- vi. Any eigenvalue can be related to its eigenfunction by the Rayleigh quotient

$$\lambda = \frac{-p(x)X(x)X'(x)|_a^b + \int_a^b \{p(x)[X'(x)]^2 - q(x)X^2(x)\} dx}{\int_a^b \sigma(x)X^2(x) dx}.$$

## 7 PDEs in Higher Dimensions

### 7.1 Introduction

In the previous chapters we discussed homogeneous time dependent one dimensional PDEs with homogeneous boundary conditions. Also Laplace's equation in two variables was solved in cartesian and polar coordinate systems. The eigenpairs of the Laplacian will be used here to solve time dependent PDEs with two or three spatial variables. We will also discuss the solution of Laplace's equation in cylindrical and spherical coordinate systems, thus allowing us to solve the heat and wave equations in those coordinate systems.

In the top part of the following table we list the various equations solved to this point. In the bottom part we list the equations to be solved in this chapter.

Equation	Type	Comments
$u_t = ku_{xx}$	heat	1D constant coefficients
$c(x)\rho(x)u_t = (K(x)u_x)_x$	heat	1D
$u_{tt} - c^2u_{xx} = 0$	wave	1D constant coefficients
$\rho(x)u_{tt} - T_0(x)u_{xx} = 0$	wave	1D
$u_{xx} + u_{yy} = 0$	Laplace	2D constant coefficients
$u_t = k(u_{xx} + u_{yy})$	heat	2D constant coefficients
$u_t = k(u_{xx} + u_{yy} + u_{zz})$	heat	3D constant coefficients
$u_{tt} - c^2(u_{xx} + u_{yy}) = 0$	wave	2D constant coefficients
$u_{tt} - c^2(u_{xx} + u_{yy} + u_{zz}) = 0$	wave	3D constant coefficients
$u_{xx} + u_{yy} + u_{zz} = 0$	Laplace	3D Cartesian
$\frac{1}{r}(ru_r)_r + \frac{1}{r^2}u_{\theta\theta} + u_{zz} = 0$	Laplace	3D Cylindrical
$u_{rr} + \frac{2}{r}u_r + \frac{1}{r^2}u_{\theta\theta} + \frac{\cot\theta}{r^2}u_\theta + \frac{1}{r^2\sin^2\theta}u_{\phi\phi} = 0$	Laplace	3D Spherical

## 7.2 Heat Flow in a Rectangular Domain

In this section we solve the heat equation in two spatial variables inside a rectangle  $L$  by  $H$ . The equation is

$$u_t = k(u_{xx} + u_{yy}), \quad 0 < x < L, \quad 0 < y < H, \quad (7.2.1)$$

$$u(0, y, t) = 0, \quad (7.2.2)$$

$$u(L, y, t) = 0, \quad (7.2.3)$$

$$u(x, 0, t) = 0, \quad (7.2.4)$$

$$u(x, H, t) = 0, \quad (7.2.5)$$

$$u(x, y, 0) = f(x, y). \quad (7.2.6)$$

Notice that the term in parentheses in (7.2.1) is  $\nabla^2 u$ . Note also that we took Dirichlet boundary conditions (i.e. specified temperature on the boundary). We can write this condition as

$$u(x, y, t) = 0. \quad \text{on the boundary} \quad (7.2.7)$$

Other possible boundary conditions are left to the reader.

The method of separation of variables will proceed as follows :

1. Let

$$u(x, y, t) = T(t)\phi(x, y) \quad (7.2.8)$$

2. Substitute in (7.2.1) and separate the variables

$$\dot{T}\phi = kT\nabla^2\phi$$

$$\frac{\dot{T}}{kT} = \frac{\nabla^2\phi}{\phi} = -\lambda$$

3. Write the ODEs

$$\dot{T}(t) + k\lambda T(t) = 0 \quad (7.2.9)$$

$$\nabla^2\phi + \lambda\phi = 0 \quad (7.2.10)$$

4. Use the homogeneous boundary condition (7.2.7) to get the boundary condition associated with (7.2.10)

$$\phi(x, y) = 0. \quad \text{on the boundary} \quad (7.2.11)$$

The only question left is how to get the solution of (7.2.10) - (7.2.11). This can be done in a similar fashion to solving Laplace's equation.

Let

$$\phi(x, y) = X(x)Y(y), \quad (7.2.12)$$

then (7.2.10) - (7.2.11) yield 2 ODEs

$$X'' + \mu X = 0, \quad (7.2.13)$$

$$X(0) = X(L) = 0, \quad (7.2.14)$$

$$Y'' + (\lambda - \mu)Y = 0, \quad (7.2.15)$$

$$Y(0) = Y(H) = 0. \quad (7.2.16)$$

The boundary conditions (7.2.14) and (7.2.16) result from (7.2.2) - (7.2.5). Equation (7.2.13) has a solution

$$X_n = \sin \frac{n\pi}{L}x, \quad n = 1, 2, \dots \quad (7.2.17)$$

$$\mu_n = \left(\frac{n\pi}{L}\right)^2, \quad n = 1, 2, \dots \quad (7.2.18)$$

as we have seen in Chapter 2. For each  $n$ , equation (7.2.15) is solved the same way

$$Y_{mn} = \sin \frac{m\pi}{H}y, \quad m = 1, 2, \dots, n = 1, 2, \dots \quad (7.2.19)$$

$$\lambda_{mn} - \mu_n = \left(\frac{m\pi}{H}\right)^2, \quad m = 1, 2, \dots, n = 1, 2, \dots \quad (7.2.20)$$

Therefore by (7.2.12) and (7.2.17)-(7.2.20),

$$\phi_{mn}(x, y) = \sin \frac{n\pi}{L}x \sin \frac{m\pi}{H}y, \quad (7.2.21)$$

$$\lambda_{mn} = \left(\frac{n\pi}{L}\right)^2 + \left(\frac{m\pi}{H}\right)^2, \quad (7.2.22)$$

$$n = 1, 2, \dots, m = 1, 2, \dots$$

Using (7.2.8) and the principle of superposition, we can write the solution of (7.2.1) as

$$u(x, y, t) = \sum_{n=1}^{\infty} \sum_{m=1}^{\infty} A_{mn} e^{-k\lambda_{mn}t} \sin \frac{n\pi}{L}x \sin \frac{m\pi}{H}y, \quad (7.2.23)$$

where  $\lambda_{mn}$  is given by (7.2.22).

To find the coefficients  $A_{mn}$ , we use the initial condition (7.2.6), that is for  $t = 0$  in (7.2.23) we get :

$$f(x, y) = \sum_{n=1}^{\infty} \sum_{m=1}^{\infty} A_{mn} \sin \frac{n\pi}{L}x \sin \frac{m\pi}{H}y, \quad (7.2.24)$$

$A_{mn}$  are the generalized Fourier coefficients (double Fourier series in this case). We can compute  $A_{mn}$  by

$$A_{mn} = \frac{\int_0^L \int_0^H f(x, y) \sin \frac{n\pi}{L}x \sin \frac{m\pi}{H}y dy dx}{\int_0^L \int_0^H \sin^2 \frac{n\pi}{L}x \sin^2 \frac{m\pi}{H}y dy dx}. \quad (7.2.25)$$

(See next section.)

Remarks :

- i. Equation (7.2.10) is called Helmholtz equation.
- ii. A more general form of the equation is

$$\nabla \cdot (p(x, y)\nabla\phi(x, y)) + q(x, y)\phi(x, y) + \lambda\sigma(x, y)\phi(x, y) = 0 \quad (7.2.26)$$

- iii. A more general boundary condition is

$$\beta_1(x, y)\phi(x, y) + \beta_2(x, y)\nabla\phi \cdot \vec{n} = 0 \quad \text{on the boundary} \quad (7.2.27)$$

where  $\vec{n}$  is a unit normal vector pointing outward. The special case  $\beta_2 \equiv 0$  yields (7.2.11).

## Problems

1. Solve the heat equation

$$u_t(x, y, t) = k(u_{xx}(x, y, t) + u_{yy}(x, y, t)),$$

on the rectangle  $0 < x < L, 0 < y < H$  subject to the initial condition

$$u(x, y, 0) = f(x, y),$$

and the boundary conditions

a.

$$\begin{aligned}u(0, y, t) &= u_x(L, y, t) = 0, \\u(x, 0, t) &= u(x, H, t) = 0.\end{aligned}$$

b.

$$\begin{aligned}u_x(0, y, t) &= u(L, y, t) = 0, \\u_y(x, 0, t) &= u_y(x, H, t) = 0.\end{aligned}$$

c.

$$\begin{aligned}u(0, y, t) &= u(L, y, t) = 0, \\u(x, 0, t) &= u_y(x, H, t) = 0.\end{aligned}$$

2. Solve the heat equation on a rectangular box

$$0 < x < L, 0 < y < H, 0 < z < W,$$

$$u_t(x, y, z, t) = k(u_{xx} + u_{yy} + u_{zz}),$$

subject to the boundary conditions

$$\begin{aligned}u(0, y, z, t) &= u(L, y, z, t) = 0, \\u(x, 0, z, t) &= u(x, H, z, t) = 0, \\u(x, y, 0, t) &= u(x, y, W, t) = 0,\end{aligned}$$

and the initial condition

$$u(x, y, z, 0) = f(x, y, z).$$

### 7.3 Vibrations of a rectangular Membrane

The method of separation of variables in this case will lead to the same Helmholtz equation. The only difference is in the T equation. the problem to solve is as follows :

$$u_{tt} = c^2(u_{xx} + u_{yy}), \quad 0 < x < L, 0 < y < H, \quad (7.3.1)$$

$$u(0, y, t) = 0, \quad (7.3.2)$$

$$u(L, y, t) = 0, \quad (7.3.3)$$

$$u(x, 0, t) = 0, \quad (7.3.4)$$

$$u_y(x, H, t) = 0, \quad (7.3.5)$$

$$u(x, y, 0) = f(x, y), \quad (7.3.6)$$

$$u_t(x, y, 0) = g(x, y). \quad (7.3.7)$$

Clearly there are two initial conditions, (7.3.6)-(7.3.7), since the PDE is second order in time. We have decided to use a Neumann boundary condition at the top  $y = H$ , to show how the solution of Helmholtz equation is affected.

The steps to follow are : (the reader is advised to compare these equations to (7.2.8)-(7.2.25))

$$u(x, y, t) = T(t)\phi(x, y), \quad (7.3.8)$$

$$\frac{\ddot{T}}{c^2 T} = \frac{\nabla^2 \phi}{\phi} = -\lambda$$

$$\ddot{T} + \lambda c^2 T = 0, \quad (7.3.9)$$

$$\nabla^2 \phi + \lambda \phi = 0, \quad (7.3.10)$$

$$\beta_1 \phi(x, y) + \beta_2 \phi_y(x, y) = 0, \quad (7.3.11)$$

where either  $\beta_1$  or  $\beta_2$  is zero depending on which side of the rectangle we are on.

$$\phi(x, y) = X(x)Y(y), \quad (7.3.12)$$

$$X'' + \mu X = 0, \quad (7.3.13)$$

$$X(0) = X(L) = 0, \quad (7.3.14)$$

$$Y'' + (\lambda - \mu)Y = 0, \quad (7.3.15)$$

$$Y(0) = Y'(H) = 0, \quad (7.3.16)$$

$$X_n = \sin \frac{n\pi}{L}x, \quad n = 1, 2, \dots \quad (7.3.17)$$

$$\mu_n = \left(\frac{n\pi}{L}\right)^2, \quad n = 1, 2, \dots \quad (7.3.18)$$

$$Y_{mn} = \sin \frac{(m - \frac{1}{2})\pi}{H}y, \quad m = 1, 2, \dots \quad n = 1, 2, \dots \quad (7.3.19)$$



$$\lambda_{mn} = \left( \frac{(m - \frac{1}{2})\pi}{H} \right)^2 + \left( \frac{n\pi}{L} \right)^2, \quad m = 1, 2, \dots \quad n = 1, 2, \dots \quad (7.3.20)$$

Note the similarity of (7.3.1)-(7.3.20) to the corresponding equations of section 4.2.

The solution

$$u(x, y, t) = \sum_{m=1}^{\infty} \sum_{n=1}^{\infty} \left( A_{mn} \cos \sqrt{\lambda_{mn}} ct + B_{mn} \sin \sqrt{\lambda_{mn}} ct \right) \sin \frac{n\pi}{L} x \sin \frac{(m - \frac{1}{2})\pi}{H} y. \quad (7.3.21)$$

Since the  $T$  equation is of second order, we end up with two sets of parameters  $A_{mn}$  and  $B_{mn}$ . These can be found by using the two initial conditions (7.3.6)-(7.3.7).

$$f(x, y) = \sum_{n=1}^{\infty} \sum_{m=1}^{\infty} A_{mn} \sin \frac{n\pi}{L} x \sin \frac{(m - \frac{1}{2})\pi}{H} y, \quad (7.3.22)$$

$$g(x, y) = \sum_{n=1}^{\infty} \sum_{m=1}^{\infty} c \sqrt{\lambda_{mn}} B_{mn} \sin \frac{n\pi}{L} x \sin \frac{(m - \frac{1}{2})\pi}{H} y. \quad (7.3.23)$$

To get (7.3.23) we need to evaluate  $u_t$  from (7.3.21) and then substitute  $t = 0$ . The coefficients are then

$$A_{mn} = \frac{\int_0^L \int_0^H f(x, y) \sin \frac{n\pi}{L} x \sin \frac{(m - \frac{1}{2})\pi}{H} y dy dx}{\int_0^L \int_0^H \sin^2 \frac{n\pi}{L} x \sin^2 \frac{(m - \frac{1}{2})\pi}{H} y dy dx}, \quad (7.3.24)$$

$$c \sqrt{\lambda_{mn}} B_{mn} = \frac{\int_0^L \int_0^H g(x, y) \sin \frac{n\pi}{L} x \sin \frac{(m - \frac{1}{2})\pi}{H} y dy dx}{\int_0^L \int_0^H \sin^2 \frac{n\pi}{L} x \sin^2 \frac{(m - \frac{1}{2})\pi}{H} y dy dx}, \quad (7.3.25)$$

## Problems

1. Solve the wave equation

$$u_{tt}(x, y, t) = c^2 (u_{xx}(x, y, t) + u_{yy}(x, y, t)),$$

on the rectangle  $0 < x < L, 0 < y < H$  subject to the initial conditions

$$u(x, y, 0) = f(x, y),$$

$$u_t(x, y, 0) = g(x, y),$$

and the boundary conditions

a.

$$u(0, y, t) = u_x(L, y, t) = 0,$$

$$u(x, 0, t) = u(x, H, t) = 0.$$

b.

$$u(0, y, t) = u(L, y, t) = 0,$$

$$u(x, 0, t) = u(x, H, t) = 0.$$

c.

$$u_x(0, y, t) = u(L, y, t) = 0,$$

$$u_y(x, 0, t) = u_y(x, H, t) = 0.$$

2. Solve the wave equation on a rectangular box

$$0 < x < L, 0 < y < H, 0 < z < W,$$

$$u_{tt}(x, y, z, t) = c^2(u_{xx} + u_{yy} + u_{zz}),$$

subject to the boundary conditions

$$u(0, y, z, t) = u(L, y, z, t) = 0,$$

$$u(x, 0, z, t) = u(x, H, z, t) = 0,$$

$$u(x, y, 0, t) = u(x, y, W, t) = 0,$$

and the initial conditions

$$u(x, y, z, 0) = f(x, y, z),$$

$$u_t(x, y, z, 0) = g(x, y, z).$$

3. Solve the wave equation on an isosceles right-angle triangle with side of length  $a$

$$u_{tt}(x, y, t) = c^2(u_{xx} + u_{yy}),$$

subject to the boundary conditions

$$u(x, 0, t) = u(0, y, t) = 0,$$

$$u(x, y, t) = 0, \quad \text{on the line} \quad x + y = a$$

and the initial conditions

$$u(x, y, 0) = f(x, y),$$

$$u_t(x, y, 0) = g(x, y).$$

## 7.4 Helmholtz Equation

As we have seen in this chapter, the method of separation of variables in two independent variables leads to Helmholtz equation,

$$\nabla^2\phi + \lambda\phi = 0$$

subject to the boundary conditions

$$\beta_1\phi(x, y) + \beta_2\phi_x(x, y) + \beta_3\phi_y(x, y) = 0.$$

Here we state a result generalizing Sturm-Liouville's from Chapter 6 of Neta.

Theorem:

1. All the eigenvalues are real.
2. There exists an infinite number of eigenvalues. There is a smallest one but no largest.
3. Corresponding to each eigenvalue, there may be many eigenfunctions.
4. The eigenfunctions  $\phi_i(x, y)$  form a complete set, i.e. any function  $f(x, y)$  can be represented by

$$\sum_i a_i\phi_i(x, y) \tag{7.4.1}$$

where the coefficients  $a_i$  are given by,

$$a_i = \frac{\int\int\phi_i f(x, y) dx dy}{\int\int\phi_i^2 dx dy} \tag{7.4.2}$$

5. Eigenfunctions belonging to different eigenvalues are orthogonal.
6. An eigenvalue  $\lambda$  can be related to the eigenfunction  $\phi(x, y)$  by Rayleigh quotient:

$$\lambda = \frac{\int\int(\nabla\phi)^2 dx dy - \oint\phi\nabla\phi \cdot \vec{n} ds}{\int\int\phi^2 dx dy} \tag{7.4.3}$$

where  $\oint$  symbolizes integration on the boundary. For example, the following Helmholtz problem (see 4.2.10-11)

$$\nabla^2\phi + \lambda\phi = 0, \quad 0 \leq x \leq L, 0 \leq y \leq H, \tag{7.4.4}$$

$$\phi = 0, \quad \text{on the boundary,} \tag{7.4.5}$$

was solved and we found

$$\lambda_{mn} = \left(\frac{n\pi}{L}\right)^2 + \left(\frac{m\pi}{H}\right)^2, \quad n = 1, 2, \dots, \quad m = 1, 2, \dots \tag{7.4.6}$$

$$\phi_{mn}(x, y) = \sin\frac{n\pi}{L}x \sin\frac{m\pi}{H}y, \quad n = 1, 2, \dots, \quad m = 1, 2, \dots \tag{7.4.7}$$

Clearly all the eigenvalues are real. The smallest one is  $\lambda_{11} = \left(\frac{\pi}{L}\right)^2 + \left(\frac{\pi}{H}\right)^2$ ,  $\lambda_{mn} \rightarrow \infty$  as  $n$  and  $m \rightarrow \infty$ . There may be multiple eigenfunctions in some cases. For example, if

$L = 2H$  then  $\lambda_{41} = \lambda_{22}$  but the eigenfunctions  $\phi_{41}$  and  $\phi_{22}$  are different. The coefficients of expansion are

$$a_{mn} = \frac{\int_0^L \int_0^H f(x, y) \phi_{mn} dx dy}{\int_0^L \int_0^H \phi_{mn}^2 dx dy} \quad (7.4.8)$$

as given by (7.2.25).

## Problems

1. Solve

$$\nabla^2 \phi + \lambda \phi = 0 \quad [0, 1] \times [0, 1/4]$$

subject to

$$\phi(0, y) = 0$$

$$\phi_x(1, y) = 0$$

$$\phi(x, 0) = 0$$

$$\phi_y(x, 1/4) = 0.$$

Show that the results of the theorem are true.

2. Solve Helmholtz equation on an isosceles right-angle triangle with side of length  $a$

$$u_{xx} + u_{yy} + \lambda u = 0,$$

subject to the boundary conditions

$$u(x, 0) = u(0, y) = 0,$$

$$u(x, y) = 0, \quad \text{on the line} \quad x + y = a.$$

## 7.5 Vibrating Circular Membrane

In this section, we discuss the solution of the wave equation inside a circle. As we have seen in sections 4.2 and 4.3, there is a similarity between the solution of the heat and wave equations. Thus we will leave the solution of the heat equation to the exercises.

The problem is:

$$u_{tt}(r, \theta, t) = c^2 \nabla^2 u, \quad 0 \leq r \leq a, 0 \leq \theta \leq 2\pi, t > 0 \quad (7.5.1)$$

subject to the boundary condition

$$u(a, \theta, t) = 0, \quad (\text{clamped membrane}) \quad (7.5.2)$$

and the initial conditions

$$u(r, \theta, 0) = \alpha(r, \theta), \quad (7.5.3)$$

$$u_t(r, \theta, 0) = \beta(r, \theta). \quad (7.5.4)$$

The method of separation of variables leads to the same set of differential equations

$$\ddot{T}(t) + \lambda c^2 T = 0, \quad (7.5.5)$$

$$\nabla^2 \phi + \lambda \phi = 0, \quad (7.5.6)$$

$$\phi(a, \theta) = 0, \quad (7.5.7)$$

Note that in polar coordinates

$$\nabla^2 \phi = \frac{1}{r} \frac{\partial}{\partial r} \left( r \frac{\partial \phi}{\partial r} \right) + \frac{1}{r^2} \frac{\partial^2 \phi}{\partial \theta^2} \quad (7.5.8)$$

Separating the variables in the Helmholtz equation (7.5.6) we have

$$\phi(r, \theta) = R(r)\Theta(\theta), \quad (7.5.9)$$

$$\Theta'' + \mu\Theta = 0 \quad (7.5.10)$$

$$\frac{d}{dr} \left( r \frac{dR}{dr} \right) + \left( \lambda r - \frac{\mu}{r} \right) R = 0. \quad (7.5.11)$$

The boundary equation (7.5.7) yields

$$R(a) = 0. \quad (7.5.12)$$

What are the other boundary conditions? Check the solution of Laplace's equation inside a circle!

$$\Theta(0) = \Theta(2\pi), \quad (\text{periodicity}) \quad (7.5.13)$$

$$\Theta'(0) = \Theta'(2\pi), \quad (7.5.14)$$

$$|R(0)| < \infty \quad (\text{boundedness}) \quad (7.5.15)$$

The equation for  $\Theta(\theta)$  can be solved (see Chapter 2)

$$\mu_m = m^2 \quad m = 0, 1, 2, \dots \quad (7.5.16)$$

$$\Theta_m = \begin{cases} \sin m\theta \\ \cos m\theta \end{cases} \quad m = 0, 1, 2, \dots \quad (7.5.17)$$

In the rest of this section, we discuss the solution of (7.5.11) subject to (7.5.12), (7.5.15). After substituting the eigenvalues  $\mu_m$  from (7.5.16), we have

$$\frac{d}{dr} \left( r \frac{dR_m}{dr} \right) + \left( \lambda r - \frac{m^2}{r} \right) R_m = 0 \quad (7.5.18)$$

$$|R_m(0)| < \infty \quad (7.5.19)$$

$$R_m(a) = 0. \quad (7.5.20)$$

Using Rayleigh quotient for this singular Sturm-Liouville problem, we can show that  $\lambda > 0$ , thus we can make the transformation

$$\rho = \sqrt{\lambda} r \quad (7.5.21)$$

which will yield Bessel's equation

$$\rho^2 \frac{d^2 R(\rho)}{d\rho^2} + \rho \frac{dR(\rho)}{d\rho} + (\rho^2 - m^2) R(\rho) = 0 \quad (7.5.22)$$

Consulting a textbook on the solution of Ordinary Differential Equations, we find:

$$R_m(\rho) = C_{1m} J_m(\rho) + C_{2m} Y_m(\rho) \quad (7.5.23)$$

where  $J_m, Y_m$  are Bessel functions of the first, second kind of order  $m$  respectively. Since we are interested in a solution satisfying (7.5.15), we should note that near  $\rho = 0$

$$J_m(\rho) \sim \begin{cases} 1 & m = 0 \\ \frac{1}{2^m m!} \rho^m & m > 0 \end{cases} \quad (7.5.24)$$

$$Y_m(\rho) \sim \begin{cases} \frac{2}{\pi} \ln \rho & m = 0 \\ -\frac{2^m (m-1)!}{\pi} \frac{1}{\rho^m} & m > 0. \end{cases} \quad (7.5.25)$$

Thus  $C_{2m} = 0$  is necessary to achieve boundedness. Thus

$$R_m(r) = C_{1m} J_m(\sqrt{\lambda} r). \quad (7.5.26)$$

In figure 49 we have plotted the Bessel functions  $J_0$  through  $J_5$ . Note that all  $J_n$  start at 0 except  $J_0$  and all the functions cross the axis infinitely many times. In figure 50 we have plotted the Bessel functions (also called Neumann functions)  $Y_0$  through  $Y_5$ . Note that the vertical axis is through  $x = 3$  and so it is not so clear that  $Y_n$  tend to  $-\infty$  as  $x \rightarrow 0$ .



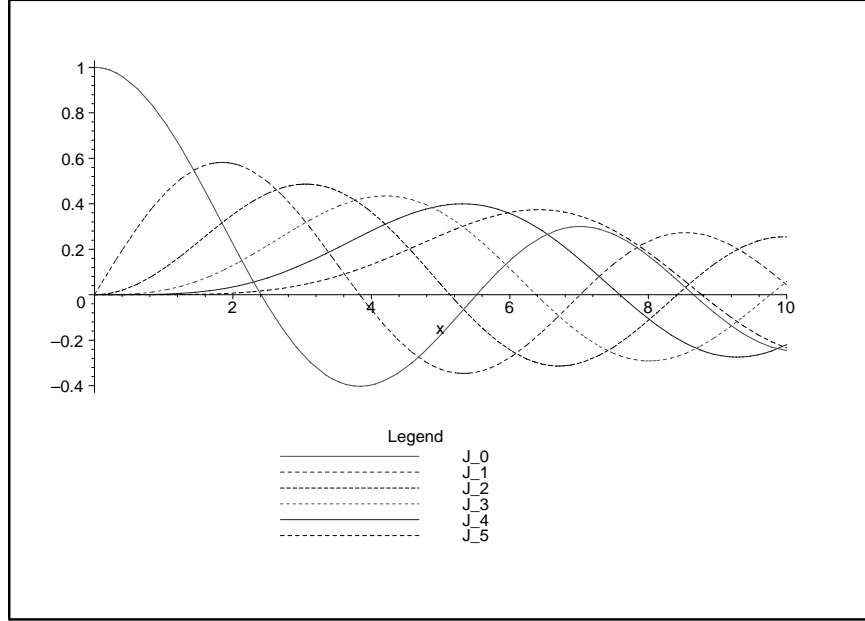

Figure 49: Bessel functions  $J_n, n = 0, \dots, 5$

To satisfy the boundary condition (7.5.20) we get an equation for the eigenvalues  $\lambda$

$$J_m(\sqrt{\lambda}a) = 0. \quad (7.5.27)$$

There are infinitely many solutions of (7.5.27) for any  $m$ . We denote these solutions by

$$\xi_{mn} = \sqrt{\lambda_{mn}}a \quad m = 0, 1, 2, \dots \quad n = 1, 2, \dots \quad (7.5.28)$$

Thus

$$\lambda_{mn} = \left( \frac{\xi_{mn}}{a} \right)^2, \quad (7.5.29)$$

$$R_{mn}(r) = J_m \left( \frac{\xi_{mn}}{a} r \right). \quad (7.5.30)$$

We leave it as an exercise to show that the general solution to (7.5.1) - (7.5.2) is given by

$$u(r, \theta, t) = \sum_{m=0}^{\infty} \sum_{n=1}^{\infty} J_m \left( \frac{\xi_{mn}}{a} r \right) \{a_{mn} \cos m\theta + b_{mn} \sin m\theta\} \left\{ A_{mn} \cos c \frac{\xi_{mn}}{a} t + B_{mn} \sin c \frac{\xi_{mn}}{a} t \right\} \quad (7.5.31)$$

We will find the coefficients by using the initial conditions (7.5.3)-(7.5.4)

$$\alpha(r, \theta) = \sum_{m=0}^{\infty} \sum_{n=1}^{\infty} J_m \left( \frac{\xi_{mn}}{a} r \right) A_{mn} \{a_{mn} \cos m\theta + b_{mn} \sin m\theta\} \quad (7.5.32)$$

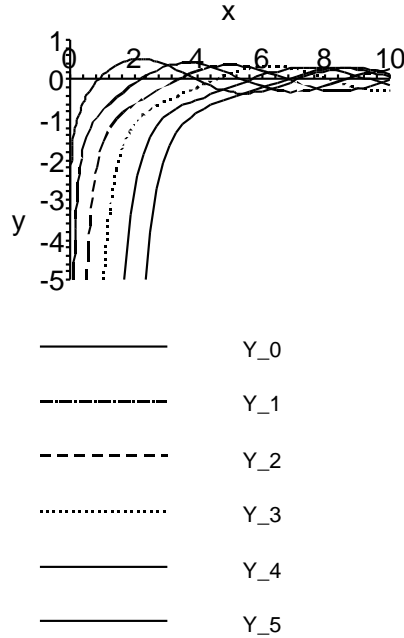

Figure 50: Bessel functions  $Y_n, n = 0, \dots, 5$

$$\beta(r, \theta) = \sum_{m=0}^{\infty} \sum_{n=1}^{\infty} J_m \left( \frac{\xi_{mn}}{a} r \right) c \frac{\xi_{mn}}{a} B_{mn} \{a_{mn} \cos m\theta + b_{mn} \sin m\theta\}. \quad (7.5.33)$$

$$A_{mn} a_{mn} = \frac{\int_0^{2\pi} \int_0^a \alpha(r, \theta) J_m \left( \frac{\xi_{mn}}{a} r \right) \cos m\theta r dr d\theta}{\int_0^{2\pi} \int_0^a J_m^2 \left( \frac{\xi_{mn}}{a} r \right) \cos^2 m\theta r dr d\theta}, \quad (7.5.34)$$

$$c \frac{\xi_{mn}}{a} B_{mn} a_{mn} = \frac{\int_0^{2\pi} \int_0^a \beta(r, \theta) J_m \left( \frac{\xi_{mn}}{a} r \right) \cos m\theta r dr d\theta}{\int_0^{2\pi} \int_0^a J_m^2 \left( \frac{\xi_{mn}}{a} r \right) \cos^2 m\theta r dr d\theta}. \quad (7.5.35)$$

Replacing  $\cos m\theta$  by  $\sin m\theta$  we get  $A_{mn} b_{mn}$  and  $c \frac{\xi_{mn}}{a} B_{mn} b_{mn}$ .

Remarks

1. Note the weight  $r$  in the integration. It comes from having  $\lambda$  multiplied by  $r$  in (7.5.18).

2. We are computing the four required combinations  $A_{mn} a_{mn}$ ,  $A_{mn} b_{mn}$ ,  $B_{mn} a_{mn}$ , and  $B_{mn} b_{mn}$ . We do not need to find  $A_{mn}$  or  $B_{mn}$  and so on.

Example:

Solve the circularly symmetric case

$$u_{tt}(r, t) = \frac{c^2}{r} \frac{\partial}{\partial r} \left( r \frac{\partial u}{\partial r} \right), \quad (7.5.36)$$

$$u(a, t) = 0, \quad (7.5.37)$$

$$u(r, 0) = \alpha(r), \quad (7.5.38)$$

$$u_t(r, 0) = \beta(r). \quad (7.5.39)$$

The reader can easily show that the separation of variables give

$$\ddot{T} + \lambda c^2 T = 0, \quad (7.5.40)$$

$$\frac{d}{dr} \left( r \frac{dR}{dr} \right) + \lambda r R = 0, \quad (7.5.41)$$

$$R(a) = 0, \quad (7.5.42)$$

$$|R(0)| < \infty. \quad (7.5.43)$$

Since there is no dependence on  $\theta$ , the  $r$  equation will have no  $\mu$ , or which is the same  $m = 0$ . Thus

$$R_0(r) = J_0(\sqrt{\lambda_n} r) \quad (7.5.44)$$

where the eigenvalues  $\lambda_n$  are computed from

$$J_0(\sqrt{\lambda_n} a) = 0. \quad (7.5.45)$$

The general solution is

$$u(r, t) = \sum_{n=1}^{\infty} a_n J_0(\sqrt{\lambda_n} r) \cos c\sqrt{\lambda_n} t + b_n J_0(\sqrt{\lambda_n} r) \sin c\sqrt{\lambda_n} t. \quad (7.5.46)$$

The coefficients  $a_n, b_n$  are given by

$$a_n = \frac{\int_0^a J_0(\sqrt{\lambda_n} r) \alpha(r) r dr}{\int_0^a J_0^2(\sqrt{\lambda_n} r) r dr}, \quad (7.5.47)$$

$$b_n = \frac{\int_0^a J_0(\sqrt{\lambda_n} r) \beta(r) r dr}{c\sqrt{\lambda_n} \int_0^a J_0^2(\sqrt{\lambda_n} r) r dr}. \quad (7.5.48)$$

## Problems

1. Solve the heat equation

$$u_t(r, \theta, t) = k\nabla^2 u, \quad 0 \leq r < a, 0 < \theta < 2\pi, t > 0$$

subject to the boundary condition

$$u(a, \theta, t) = 0 \quad (\text{zero temperature on the boundary})$$

and the initial condition

$$u(r, \theta, 0) = \alpha(r, \theta).$$

2. Solve the wave equation

$$u_{tt}(r, t) = c^2(u_{rr} + \frac{1}{r}u_r),$$

$$u_r(a, t) = 0,$$

$$u(r, 0) = \alpha(r),$$

$$u_t(r, 0) = 0.$$

Show the details.

3. Consult numerical analysis textbook to obtain the smallest eigenvalue of the above problem.

4. Solve the wave equation

$$u_{tt}(r, \theta, t) - c^2\nabla^2 u = 0, \quad 0 \leq r < a, 0 < \theta < 2\pi, t > 0$$

subject to the boundary condition

$$u_r(a, \theta, t) = 0$$

and the initial conditions

$$u(r, \theta, 0) = 0,$$

$$u_t(r, \theta, 0) = \beta(r) \cos 5\theta.$$

5. Solve the wave equation

$$u_{tt}(r, \theta, t) - c^2\nabla^2 u = 0, \quad 0 \leq r < a, 0 < \theta < \pi/2, t > 0$$

subject to the boundary conditions

$$u(a, \theta, t) = u(r, 0, t) = u(r, \pi/2, t) = 0 \quad (\text{zero displacement on the boundary})$$

and the initial conditions

$$u(r, \theta, 0) = \alpha(r, \theta),$$

$$u_t(r, \theta, 0) = 0.$$

## 7.6 Laplace's Equation in a Circular Cylinder

Laplace's equation in cylindrical coordinates is given by:

$$\frac{1}{r}(ru_r)_r + \frac{1}{r^2}u_{\theta\theta} + u_{zz} = 0, \quad 0 \leq r < a, 0 < z < H, 0 < \theta < 2\pi. \quad (7.6.1)$$

The boundary conditions we discuss here are:

$$u(r, \theta, 0) = \alpha(r, \theta), \quad \text{on bottom of cylinder,} \quad (7.6.2)$$

$$u(r, \theta, H) = \beta(r, \theta), \quad \text{on top of cylinder,} \quad (7.6.3)$$

$$u(a, \theta, z) = \gamma(\theta, z), \quad \text{on lateral surface of cylinder.} \quad (7.6.4)$$

Similar methods can be employed if the boundary conditions are not of Dirichlet type (see exercises).

As we have done previously with Laplace's equation, we use the principle of superposition to get two homogenous boundary conditions. Thus we have the following three problems to solve, each differ from the others in the boundary conditions:

Problem 1:

$$\frac{1}{r}(ru_r)_r + \frac{1}{r^2}u_{\theta\theta} + u_{zz} = 0, \quad (7.6.5)$$

$$u(r, \theta, 0) = 0, \quad (7.6.6)$$

$$u(r, \theta, H) = \beta(r, \theta), \quad (7.6.7)$$

$$u(a, \theta, z) = 0, \quad (7.6.8)$$

Problem 2:

$$\frac{1}{r}(ru_r)_r + \frac{1}{r^2}u_{\theta\theta} + u_{zz} = 0, \quad (7.6.9)$$

$$u(r, \theta, 0) = \alpha(r, \theta), \quad (7.6.10)$$

$$u(r, \theta, H) = 0, \quad (7.6.11)$$

$$u(a, \theta, z) = 0, \quad (7.6.12)$$

Problem 3:

$$\frac{1}{r}(ru_r)_r + \frac{1}{r^2}u_{\theta\theta} + u_{zz} = 0, \quad (7.6.13)$$

$$u(r, \theta, 0) = 0, \quad (7.6.14)$$

$$u(r, \theta, H) = 0, \quad (7.6.15)$$

$$u(a, \theta, z) = \gamma(\theta, z). \quad (7.6.16)$$

Since the PDE is the same in all three problems, we get the same set of ODEs

$$\Theta'' + \mu\Theta = 0, \quad (7.6.17)$$

$$Z'' - \lambda Z = 0, \quad (7.6.18)$$

$$r(rR')' + (\lambda r^2 - \mu)R = 0. \quad (7.6.19)$$

Recalling Laplace's equation in polar coordinates, the boundary conditions associated with (7.6.17) are

$$\Theta(0) = \Theta(2\pi), \quad (7.6.20)$$

$$\Theta'(0) = \Theta'(2\pi), \quad (7.6.21)$$

and one of the boundary conditions for (7.6.19) is

$$|R(0)| < \infty. \quad (7.6.22)$$

The other boundary conditions depend on which of the three we are solving. For problem 1, we have

$$Z(0) = 0, \quad (7.6.23)$$

$$R(a) = 0. \quad (7.6.24)$$

Clearly, the equation for  $\Theta$  can be solved yielding

$$\mu_m = m^2, \quad m=0,1,2,\dots \quad (7.6.25)$$

$$\Theta_m = \begin{cases} \sin m\theta \\ \cos m\theta. \end{cases} \quad (7.6.26)$$

Now the  $R$  equation is solvable

$$R(r) = J_m(\sqrt{\lambda_{mn}}r), \quad (7.6.27)$$

where  $\lambda_{mn}$  are found from (7.6.24) or equivalently

$$J_m(\sqrt{\lambda_{mn}}a) = 0, \quad n=1,2,3,\dots \quad (7.6.28)$$

Since  $\lambda > 0$  (related to the zeros of Bessel's functions), then the  $Z$  equation has the solution

$$Z(z) = \sinh \sqrt{\lambda_{mn}}z. \quad (7.6.29)$$

Combining the solutions of the ODEs, we have for problem 1:

$$u(r, \theta, z) = \sum_{m=0}^{\infty} \sum_{n=1}^{\infty} \sinh \sqrt{\lambda_{mn}}z J_m(\sqrt{\lambda_{mn}}r) (A_{mn} \cos m\theta + B_{mn} \sin m\theta), \quad (7.6.30)$$

where  $A_{mn}$  and  $B_{mn}$  can be found from the generalized Fourier series of  $\beta(r, \theta)$ . The second problem follows the same pattern, replacing (7.6.23) by

$$Z(H) = 0, \quad (7.6.31)$$

leading to

$$u(r, \theta, z) = \sum_{m=0}^{\infty} \sum_{n=1}^{\infty} \sinh\left(\sqrt{\lambda_{mn}}(z-H)\right) J_m(\sqrt{\lambda_{mn}}r) (C_{mn} \cos m\theta + D_{mn} \sin m\theta), \quad (7.6.32)$$

where  $C_{mn}$  and  $D_{mn}$  can be found from the generalized Fourier series of  $\alpha(r, \theta)$ .

The third problem is slightly different. Since there is only one boundary condition for  $R$ , we must solve the  $Z$  equation (7.6.18) before we solve the  $R$  equation. The boundary conditions for the  $Z$  equation are

$$Z(0) = Z(H) = 0, \quad (7.6.33)$$

which result from (7.6.14-7.6.15). The solution of (7.6.18), (7.6.33) is

$$Z_n = \sin \frac{n\pi}{H} z, \quad n = 1, 2, \dots \quad (7.6.34)$$

The eigenvalues

$$\lambda_n = \left(\frac{n\pi}{H}\right)^2, \quad n = 1, 2, \dots \quad (7.6.35)$$

should be substituted in the  $R$  equation to yield

$$r(rR)' - \left[ \left(\frac{n\pi}{H}\right)^2 r^2 + m^2 \right] R = 0. \quad (7.6.36)$$

This equation looks like Bessel's equation but with the wrong sign in front of  $r^2$  term. It is called the modified Bessel's equation and has a solution

$$R(r) = c_1 I_m\left(\frac{n\pi}{H}r\right) + c_2 K_m\left(\frac{n\pi}{H}r\right). \quad (7.6.37)$$

The modified Bessel functions of the first ( $I_m$ , also called hyperbolic Bessel functions) and the second ( $K_m$ , also called Basset functions) kinds behave at zero and infinity similar to  $J_m$  and  $Y_m$  respectively. In figure 51 we have plotted the Bessel functions  $I_0$  through  $I_5$ . In figure 52 we have plotted the Bessel functions  $K_n, n = 0, 1, 2, 3$ . Note that the vertical axis is through  $x = .9$  and so it is not so clear that  $K_n$  tend to  $\infty$  as  $x \rightarrow 0$ .

Therefore the solution to the third problem is

$$u(r, \theta, z) = \sum_{m=0}^{\infty} \sum_{n=1}^{\infty} \sin \frac{n\pi}{H} z I_m\left(\frac{n\pi}{H}r\right) (E_{mn} \cos m\theta + F_{mn} \sin m\theta), \quad (7.6.38)$$

where  $E_{mn}$  and  $F_{mn}$  can be found from the generalized Fourier series of  $\gamma(\theta, z)$ . The solution of the original problem (7.6.1-7.6.4) is the sum of the solutions given by (7.6.30), (7.6.32) and (7.6.38).

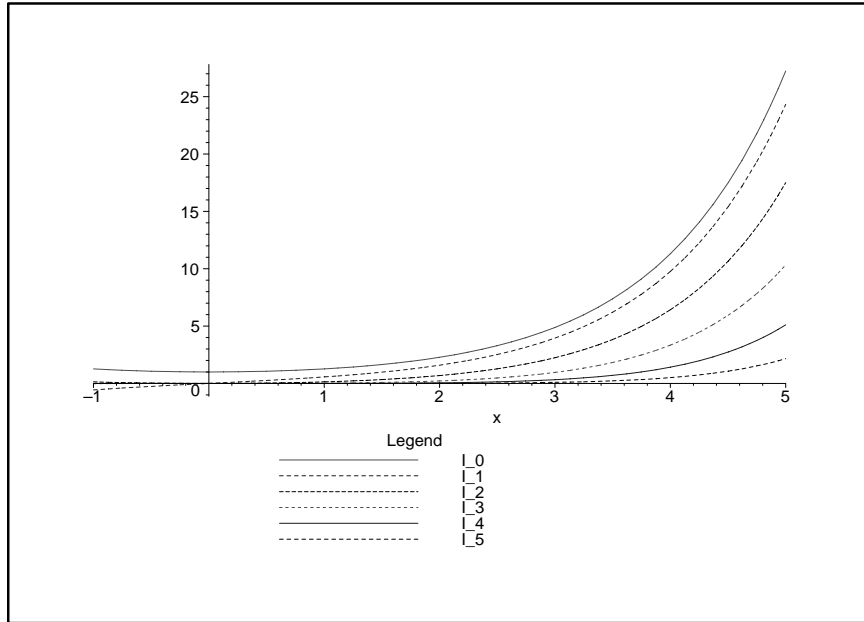

Figure 51: Bessel functions  $I_n, n = 0, \dots, 4$

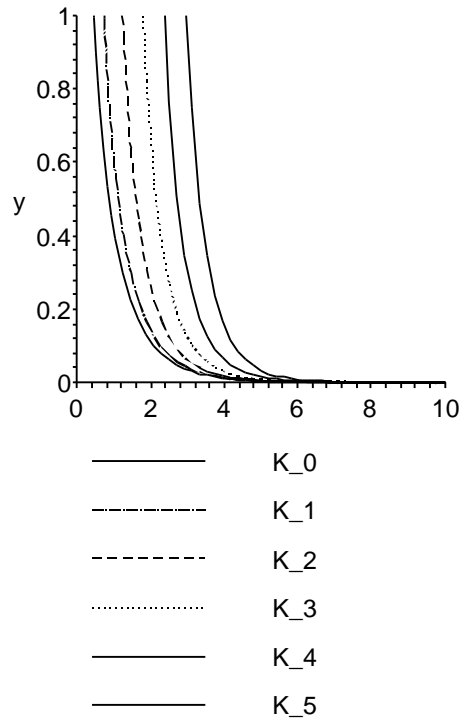

Figure 52: Bessel functions  $K_n, n = 0, \dots, 3$



## Problems

1. Solve Laplace's equation

$$\frac{1}{r}(ru_r)_r + \frac{1}{r^2}u_{\theta\theta} + u_{zz} = 0, \quad 0 \leq r < a, 0 < \theta < 2\pi, 0 < z < H$$

subject to each of the boundary conditions

a.

$$\begin{aligned} u(r, \theta, 0) &= \alpha(r, \theta) \\ u(r, \theta, H) &= u(a, \theta, z) = 0 \end{aligned}$$

b.

$$\begin{aligned} u(r, \theta, 0) &= u(r, \theta, H) = 0 \\ u_r(a, \theta, z) &= \gamma(\theta, z) \end{aligned}$$

c.

$$\begin{aligned} u_z(r, \theta, 0) &= \alpha(r, \theta) \\ u(r, \theta, H) &= u(a, \theta, z) = 0 \end{aligned}$$

d.

$$\begin{aligned} u(r, \theta, 0) &= u_z(r, \theta, H) = 0 \\ u_r(a, \theta, z) &= \gamma(z) \end{aligned}$$

2. Solve Laplace's equation

$$\frac{1}{r}(ru_r)_r + \frac{1}{r^2}u_{\theta\theta} + u_{zz} = 0, \quad 0 \leq r < a, 0 < \theta < \pi, 0 < z < H$$

subject to the boundary conditions

$$\begin{aligned} u(r, \theta, 0) &= 0, \\ u_z(r, \theta, H) &= 0, \\ u(r, 0, z) &= u(r, \pi, z) = 0, \\ u(a, \theta, z) &= \beta(\theta, z). \end{aligned}$$

3. Find the solution to the following steady state heat conduction problem in a box

$$\nabla^2 u = 0, \quad 0 \leq x < L, 0 < y < L, 0 < z < W,$$

subject to the boundary conditions

$$\frac{\partial u}{\partial x} = 0, \quad x = 0, x = L,$$

$$\begin{aligned}\frac{\partial u}{\partial y} &= 0, & y = 0, y = L, \\ u(x, y, W) &= 0, \\ u(x, y, 0) &= 4 \cos \frac{3\pi}{L}x \cos \frac{4\pi}{L}y.\end{aligned}$$

4. Find the solution to the following steady state heat conduction problem in a box

$$\nabla^2 u = 0, \quad 0 \leq x < L, 0 < y < L, 0 < z < W,$$

subject to the boundary conditions

$$\begin{aligned}\frac{\partial u}{\partial x} &= 0, & x = 0, x = L, \\ \frac{\partial u}{\partial y} &= 0, & y = 0, y = L, \\ u_z(x, y, W) &= 0, \\ u_z(x, y, 0) &= 4 \cos \frac{3\pi}{L}x \cos \frac{4\pi}{L}y.\end{aligned}$$

5. Solve the heat equation inside a cylinder

$$\frac{\partial u}{\partial t} = \frac{1}{r} \frac{\partial}{\partial r} \left( r \frac{\partial u}{\partial r} \right) + \frac{1}{r^2} \frac{\partial^2 u}{\partial \theta^2} + \frac{\partial^2 u}{\partial z^2}, \quad 0 \leq r < a, 0 < \theta < 2\pi, 0 < z < H$$

subject to the boundary conditions

$$u(r, \theta, 0, t) = u(r, \theta, H, t) = 0,$$

$$u(a, \theta, z, t) = 0,$$

and the initial condition

$$u(r, \theta, z, 0) = f(r, \theta, z).$$

## 7.7 Laplace's equation in a sphere

Laplace's equation in spherical coordinates is given in the form

$$u_{rr} + \frac{2}{r}u_r + \frac{1}{r^2}u_{\theta\theta} + \frac{\cot \theta}{r^2}u_\theta + \frac{1}{r^2 \sin^2 \theta}u_{\varphi\varphi} = 0, \quad 0 \leq r < a, 0 < \theta < \pi, 0 < \varphi < 2\pi, \quad (7.7.1)$$

$\varphi$  is the longitude and  $\frac{\pi}{2} - \theta$  is the latitude. Suppose the boundary condition is

$$u(a, \theta, \varphi) = f(\theta, \varphi). \quad (7.7.2)$$

To solve by the method of separation of variables we assume a solution  $u(r, \theta, \varphi)$  in the form

$$u(r, \theta, \varphi) = R(r)\Theta(\theta)\Phi(\varphi). \quad (7.7.3)$$

Substitution in Laplace's equation yields

$$\left(R'' + \frac{2}{r}R'\right)\Theta\Phi + \frac{1}{r^2}R\Theta''\Phi + \frac{\cot \theta}{r^2}\Theta'R\Phi + \frac{1}{r^2 \sin^2 \theta}R\Theta\Phi'' = 0$$

Multiplying by  $\frac{r^2 \sin^2 \theta}{R\Theta\Phi}$ , we can separate the  $\varphi$  dependence:

$$r^2 \sin^2 \theta \left[ \frac{R''}{R} + \frac{2}{r} \frac{R'}{R} + \frac{1}{r^2} \frac{\Theta''}{\Theta} + \frac{\cot \theta}{r^2} \frac{\Theta'}{\Theta} \right] = -\frac{\Phi''}{\Phi} = \mu.$$

Now the ODE for  $\varphi$  is

$$\Phi'' + \mu\Phi = 0 \quad (7.7.4)$$

and the equation for  $r, \theta$  can be separated by dividing through by  $\sin^2 \theta$

$$r^2 \frac{R''}{R} + 2r \frac{R'}{R} + \frac{\Theta''}{\Theta} + \cot \theta \frac{\Theta'}{\Theta} = \frac{\mu}{\sin^2 \theta}.$$

Keeping the first two terms on the left, we have

$$r^2 \frac{R''}{R} + 2r \frac{R'}{R} = -\frac{\Theta''}{\Theta} - \cot \theta \frac{\Theta'}{\Theta} + \frac{\mu}{\sin^2 \theta} = \lambda.$$

Thus

$$r^2 R'' + 2rR' - \lambda R = 0 \quad (7.7.5)$$

and

$$\Theta'' + \cot \theta \Theta' - \frac{\mu}{\sin^2 \theta} \Theta + \lambda \Theta = 0.$$

The equation for  $\Theta$  can be written as follows

$$\sin^2 \theta \Theta'' + \sin \theta \cos \theta \Theta' + (\lambda \sin^2 \theta - \mu) \Theta = 0. \quad (7.7.6)$$

What are the boundary conditions? Clearly, we have periodicity of  $\Phi$ , i.e.

$$\Phi(0) = \Phi(2\pi) \quad (7.7.7)$$

$$\Phi'(0) = \Phi'(2\pi) . \quad (7.7.8)$$

The solution  $R(r)$  must be finite at zero, i.e.

$$|R(0)| < \infty \quad (7.7.9)$$

as we have seen in other problems on a circular domain that include the pole,  $r = 0$ . Thus we can solve the ODE (7.7.4) subject to the conditions (7.7.7) - (7.7.8). This yields the eigenvalues

$$\mu_m = m^2 \quad m = 0, 1, 2, \dots \quad (7.7.10)$$

and eigenfunctions

$$\Phi_m = \begin{cases} \cos m\varphi \\ \sin m\varphi \end{cases} \quad m = 1, 2, \dots \quad (7.7.11)$$

and

$$\Phi_0 = 1. \quad (7.7.12)$$

We can solve (7.7.5) which is Euler's equation, by trying

$$R(r) = r^\alpha \quad (7.7.13)$$

yielding a characteristic equation

$$\alpha^2 + \alpha - \lambda = 0 . \quad (7.7.14)$$

The solutions of the characteristic equation are

$$\alpha_{1,2} = \frac{-1 \pm \sqrt{1 + 4\lambda}}{2}. \quad (7.7.15)$$

Thus if we take

$$\alpha_1 = \frac{-1 + \sqrt{1 + 4\lambda}}{2} \quad (7.7.16)$$

then

$$\alpha_2 = -(1 + \alpha_1) \quad (7.7.17)$$

and

$$\lambda = \alpha_1(1 + \alpha_1) . \quad (7.7.18)$$

(Recall that the sum of the roots equals the negative of the coefficient of the linear term and the product of the roots equals the constant term.) Therefore the solution is

$$R(r) = Cr^{\alpha_1} + Dr^{-(\alpha_1+1)} \quad (7.7.19)$$

Using the boundedness condition (7.7.9) we must have  $D = 0$  and the solution of (7.7.5) becomes

$$R(r) = Cr^{\alpha_1} . \quad (7.7.20)$$

Substituting  $\lambda$  and  $\mu$  from (7.7.18) and (7.7.10) into the third ODE (7.7.6), we have

$$\sin^2 \theta \Theta'' + \sin \theta \cos \theta \Theta' + \left( \alpha_1(1 + \alpha_1) \sin^2 \theta - m^2 \right) \Theta = 0 . \quad (7.7.21)$$

Now, lets make the transformation

$$\xi = \cos \theta \quad (7.7.22)$$

then

$$\frac{d\Theta}{d\theta} = \frac{d\Theta}{d\xi} \frac{d\xi}{d\theta} = -\sin \theta \frac{d\Theta}{d\xi} \quad (7.7.23)$$

and

$$\begin{aligned} \frac{d^2\Theta}{d\theta^2} &= -\frac{d}{d\theta} \left( \sin \theta \frac{d\Theta}{d\xi} \right) \\ &= -\cos \theta \frac{d\Theta}{d\xi} - \sin \theta \frac{d^2\Theta}{d\xi^2} \frac{d\xi}{d\theta} \\ &= -\cos \theta \frac{d\Theta}{d\xi} + \sin^2 \theta \frac{d^2\Theta}{d\xi^2} . \end{aligned} \quad (7.7.24)$$

Substitute (7.7.22) - (7.7.24) in (7.7.21) we have

$$\sin^4 \theta \frac{d^2\Theta}{d\xi^2} - \sin^2 \theta \cos \theta \frac{d\Theta}{d\xi} - \sin^2 \theta \cos \theta \frac{d\Theta}{d\xi} + \left( \alpha_1(1 + \alpha_1) \sin^2 \theta - m^2 \right) \Theta = 0 .$$

Divide through by  $\sin^2 \theta$  and use (7.7.22), we get

$$(1 - \xi^2)\Theta'' - 2\xi\Theta' + \left( \alpha_1(1 + \alpha_1) - \frac{m^2}{1 - \xi^2} \right) \Theta = 0 . \quad (7.7.25)$$

This is the so-called associated Legendre equation.

For  $m = 0$ , the equation is called Legendre's equation. Using power series method of solution, one can show that Legendre's equation (see e.g. Pinsky (1991))

$$(1 - \xi^2)\Theta'' - 2\xi\Theta' + \alpha_1(1 + \alpha_1)\Theta = 0 . \quad (7.7.26)$$

has a solution

$$\Theta(\xi) = \sum_{i=0}^{\infty} a_i \xi^i . \quad (7.7.27)$$

where

$$a_{i+2} = \frac{i(i+1) - \alpha_1(1 + \alpha_1)}{(i+1)(i+2)} a_i , \quad i = 0, 1, 2, \dots . \quad (7.7.28)$$

and  $a_0, a_1$  may be chosen arbitrarily.

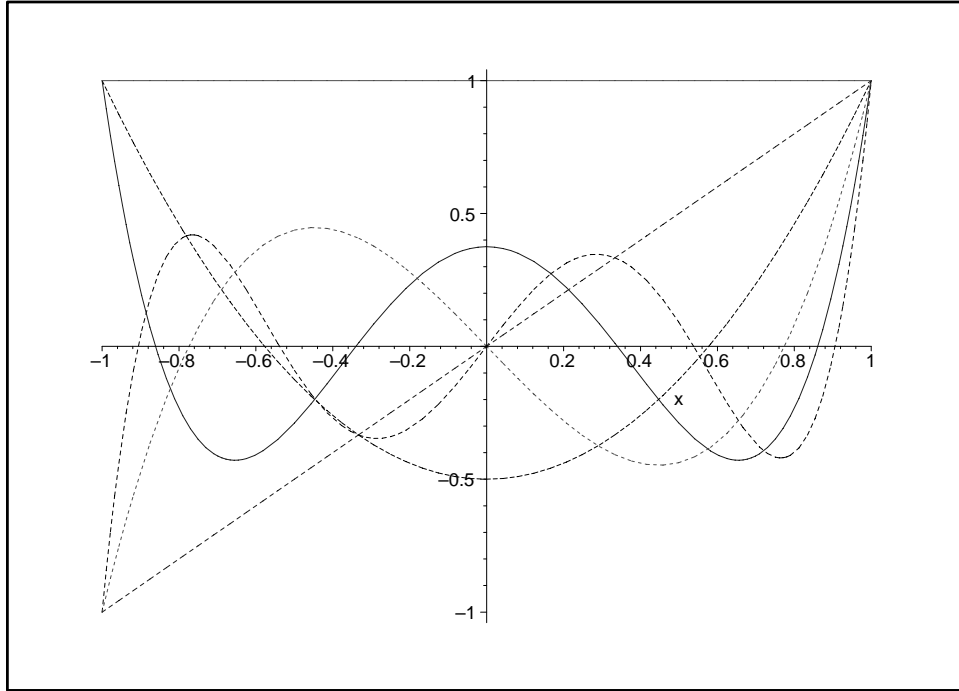

Figure 53: Legendre polynomials  $P_n, n = 0, \dots, 5$

If  $\alpha_1$  is an integer  $n$ , then the recurrence relation (7.7.28) shows that one of the solutions is a polynomial of degree  $n$ . (If  $n$  is even, choose  $a_1 = 0, a_0 \neq 0$  and if  $n$  is odd, choose  $a_0 = 0, a_1 \neq 0$ .) This polynomial is denoted by  $P_n(\xi)$ . The first four Legendre polynomials are

$$\begin{aligned}
 P_0 &= 1 \\
 P_1 &= \xi \\
 P_2 &= \frac{3}{2}\xi^2 - \frac{1}{2} \\
 P_3 &= \frac{5}{2}\xi^3 - \frac{3}{2}\xi \\
 P_4 &= \frac{35}{8}\xi^4 - \frac{30}{8}\xi^2 + \frac{3}{8}.
 \end{aligned} \tag{7.7.29}$$

In figure 53, we have plotted the first 6 Legendre polynomials. The orthogonality of Legendre polynomials can be easily shown

$$\int_{-1}^1 P_n(\xi)P_\ell(\xi)d\xi = 0, \quad \text{for } n \neq \ell \tag{7.7.30}$$

or

$$\int_0^\pi P_n(\cos \theta)P_\ell(\cos \theta) \sin \theta d\theta = 0, \quad \text{for } n \neq \ell. \tag{7.7.31}$$

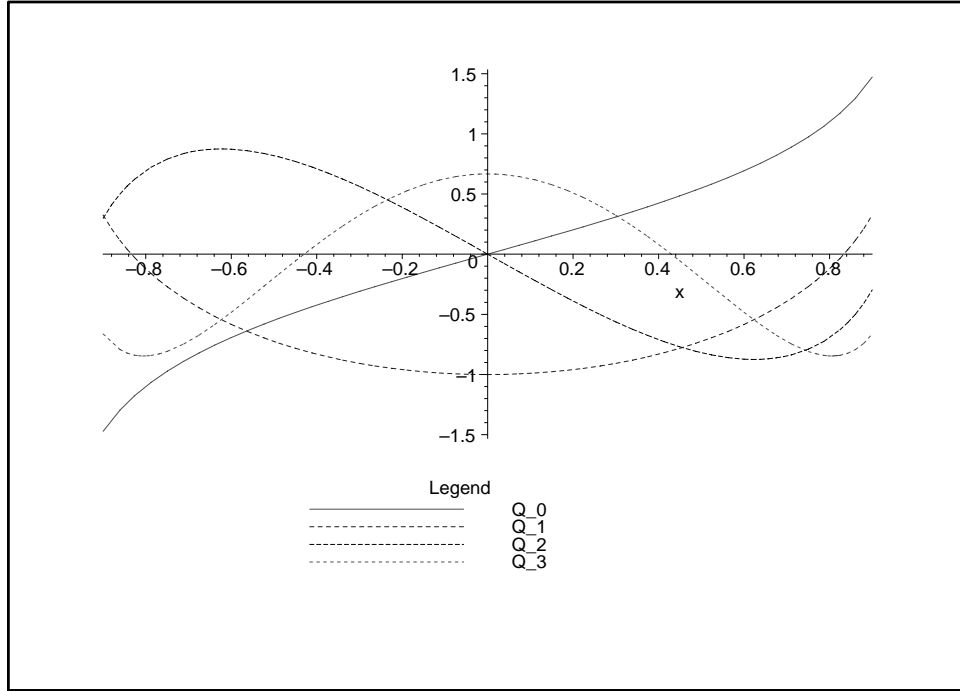

Figure 54: Legendre functions  $Q_n, n = 0, \dots, 3$

The other solution is not a polynomial and denoted by  $Q_n(\xi)$ . In fact these functions can be written in terms of inverse hyperbolic tangent.

$$\begin{aligned}
 Q_0 &= \tanh^{-1} \xi \\
 Q_1 &= \xi \tanh^{-1} \xi - 1 \\
 Q_2 &= \frac{3\xi^2 - 1}{2} \tanh^{-1} \xi - \frac{3\xi}{2} \\
 Q_3 &= \frac{5\xi^3 - 3\xi}{2} \tanh^{-1} \xi - \frac{15\xi^2 - 4}{6}.
 \end{aligned} \tag{7.7.32}$$

Now back to (7.7.25), differentiating (7.7.26)  $m$  times with respect to  $\theta$ , one has (7.7.25). Therefore, one solution is

$$P_n^m(\cos \theta) = \sin^m \theta \frac{d^m}{d\theta^m} P_n(\cos \theta), \quad \text{for } m \leq n \tag{7.7.33}$$

or in terms of  $\xi$

$$P_n^m(\xi) = (1 - \xi^2)^{m/2} \frac{d^m}{d\xi^m} P_n(\xi), \quad \text{for } m \leq n \tag{7.7.34}$$

which are the associated Legendre polynomials. The other solution is

$$Q_n^m(\xi) = (1 - \xi^2)^{m/2} \frac{d^m}{d\xi^m} Q_n(\xi). \tag{7.7.35}$$

The general solution is then

$$\Theta_{nm}(\theta) = AP_n^m(\cos \theta) + BQ_n^m(\cos \theta), \quad n = 0, 1, 2, \dots \quad (7.7.36)$$

Since  $Q_n^m$  has a logarithmic singularity at  $\theta = 0$ , we must have  $B = 0$ . Therefore, the solution becomes

$$\Theta_{nm}(\theta) = AP_n^m(\cos \theta). \quad (7.7.37)$$

Combining (7.7.11), (7.7.12), (7.7.19) and (7.7.37) we can write

$$u(r, \theta, \varphi) = \sum_{n=0}^{\infty} A_{n0} r^n P_n(\cos \theta) + \sum_{n=0}^{\infty} \sum_{m=1}^n r^n P_n^m(\cos \theta) (A_{nm} \cos m\varphi + B_{mn} \sin m\varphi). \quad (7.7.38)$$

where  $P_n(\cos \theta) = P_n^0(\cos \theta)$  are Legendre polynomials. The boundary condition (7.7.2) implies

$$f(\theta, \varphi) = \sum_{n=0}^{\infty} A_{n0} a^n P_n(\cos \theta) + \sum_{n=0}^{\infty} \sum_{m=1}^n a^n P_n^m(\cos \theta) (A_{nm} \cos m\varphi + B_{mn} \sin m\varphi). \quad (7.7.39)$$

The coefficients  $A_{n0}$ ,  $A_{nm}$ ,  $B_{nm}$  can be obtained from

$$A_{n0} = \frac{\int_0^{2\pi} \int_0^{\pi} f(\theta, \varphi) P_n(\cos \theta) \sin \theta d\theta d\varphi}{2\pi a^n I_0} \quad (7.7.40)$$

$$A_{nm} = \frac{\int_0^{2\pi} \int_0^{\pi} f(\theta, \varphi) P_n^m(\cos \theta) \cos m\varphi \sin \theta d\theta d\varphi}{\pi a^n I_m} \quad (7.7.41)$$

$$B_{nm} = \frac{\int_0^{2\pi} \int_0^{\pi} f(\theta, \varphi) P_n^m(\cos \theta) \sin m\varphi \sin \theta d\theta d\varphi}{\pi a^n I_m} \quad (7.7.42)$$

where

$$\begin{aligned} I_m &= \int_0^{\pi} [P_n^m(\cos \theta)]^2 \sin \theta d\theta \\ &= \frac{2(n+m)!}{(2n+1)(n-m)!}. \end{aligned} \quad (7.7.43)$$



## Problems

1. Solve Laplace's equation on the sphere

$$u_{rr} + \frac{2}{r}u_r + \frac{1}{r^2}u_{\theta\theta} + \frac{\cot \theta}{r^2}u_\theta + \frac{1}{r^2 \sin^2 \theta}u_{\varphi\varphi} = 0, \quad 0 \leq r < a, \quad 0 < \theta < \pi, \quad 0 < \varphi < 2\pi,$$

subject to the boundary condition

$$u_r(a, \theta, \varphi) = f(\theta).$$

2. Solve Laplace's equation on the half sphere

$$u_{rr} + \frac{2}{r}u_r + \frac{1}{r^2}u_{\theta\theta} + \frac{\cot \theta}{r^2}u_\theta + \frac{1}{r^2 \sin^2 \theta}u_{\varphi\varphi} = 0, \quad 0 \leq r < a, \quad 0 < \theta < \pi, \quad 0 < \varphi < \pi,$$

subject to the boundary conditions

$$u(a, \theta, \varphi) = f(\theta, \varphi),$$

$$u(r, \theta, 0) = u(r, \theta, \pi) = 0.$$

3. Solve Laplace's equation on the surface of the sphere of radius  $a$ .

**SUMMARY**  
Heat Equation

$$u_t = k(u_{xx} + u_{yy})$$

$$u_t = k(u_{xx} + u_{yy} + u_{zz})$$

$$u_t = k \left\{ \frac{1}{r} \frac{\partial}{\partial r} \left( r \frac{\partial u}{\partial r} \right) + \frac{1}{r^2} \frac{\partial^2 u}{\partial \theta^2} \right\}$$

Wave equation

$$u_{tt} - c^2(u_{xx} + u_{yy}) = 0$$

$$u_{tt} - c^2(u_{xx} + u_{yy} + u_{zz}) = 0$$

$$u_{tt} = c^2 \left\{ \frac{1}{r} \frac{\partial}{\partial r} \left( r \frac{\partial u}{\partial r} \right) + \frac{1}{r^2} \frac{\partial^2 u}{\partial \theta^2} \right\}$$

Laplace's Equation

$$u_{xx} + u_{yy} + u_{zz} = 0$$

$$\frac{1}{r}(ru_r)_r + \frac{1}{r^2}u_{\theta\theta} + u_{zz} = 0$$

$$u_{rr} + \frac{2}{r}u_r + \frac{1}{r^2}u_{\theta\theta} + \frac{\cot \theta}{r^2}u_\theta + \frac{1}{r^2 \sin^2 \theta}u_{\phi\phi} = 0$$

Bessel's Equation (inside a circle)

$$(rR'_m)' + \left( \lambda r - \frac{m^2}{r} \right) R_m = 0, \quad m = 0, 1, 2, \dots$$

$$|R_m(0)| < \infty$$

$$R_m(a) = 0$$

$$R_m(r) = J_m \left( \sqrt{\lambda_{mn}} r \right) \quad \text{eigenfunctions}$$

$$J_m \left( \sqrt{\lambda_{mn}} a \right) = 0 \quad \text{equation for eigenvalues.}$$

Bessel's Equation (outside a circle)

$$(rR'_m)' + \left( \lambda r - \frac{m^2}{r} \right) R_m = 0, \quad m = 0, 1, 2, \dots$$

$$R_m \rightarrow 0 \quad \text{as} \quad r \rightarrow \infty$$

$$R_m(a) = 0$$

$$R_m(r) = Y_m \left( \sqrt{\lambda_{mn}} r \right) \quad \text{eigenfunctions}$$

$$Y_m \left( \sqrt{\lambda_{mn}} a \right) = 0 \quad \text{equation for eigenvalues.}$$

Modified Bessel's Equation

$$(rR'_m)' - \left(\lambda^2 r + \frac{m^2}{r}\right) R_m = 0, \quad m = 0, 1, 2, \dots$$

$$R_m(r) = C_{1m}I_m(\lambda r) + C_{2m}K_m(\lambda r)$$

If  $|R_m(0)| < \infty$  then  $C_{2m} = 0$ .

Legendre's Equation

$$(1 - \xi^2)\Theta'' - 2\xi\Theta' + \alpha(1 + \alpha)\Theta = 0$$

$$\Theta(\xi) = C_1P_n(\xi) + C_2Q_n(\xi)$$

$$\alpha = n$$

Associated Legendre Equation

$$(1 - \xi^2)\Theta'' - 2\xi\Theta' + \left(\alpha(1 + \alpha) - \frac{m^2}{1 - \xi^2}\right)\Theta = 0$$

$$\Theta(\xi) = C_1P_n^m(\xi) + C_2Q_n^m(\xi)$$

$$\alpha = n$$

## 8 Separation of Variables-Nonhomogeneous Problems

In this chapter, we show how to solve nonhomogeneous problems via the separation of variables method. The first section will show how to deal with inhomogeneous boundary conditions. The second section will present the method of eigenfunctions expansion for the inhomogeneous heat equation in one space variable. The third section will give the solution of the wave equation in two dimensions. We close the chapter with the solution of Poisson's equation.

### 8.1 Inhomogeneous Boundary Conditions

Consider the following inhomogeneous heat conduction problem:

$$u_t = ku_{xx} + S(x, t), \quad 0 < x < L \quad (8.1.1)$$

subject to the inhomogeneous boundary conditions

$$u(0, t) = A(t), \quad (8.1.2)$$

$$u(L, t) = B(t), \quad (8.1.3)$$

and an initial condition

$$u(x, 0) = f(x). \quad (8.1.4)$$

Find a function  $w(x, t)$  satisfying the boundary conditions (8.1.2)-(8.1.3). It is easy to see that

$$w(x, t) = A(t) + \frac{x}{L} (B(t) - A(t)) \quad (8.1.5)$$

is one such function.

Let

$$v(x, t) = u(x, t) - w(x, t) \quad (8.1.6)$$

then clearly

$$v(0, t) = u(0, t) - w(0, t) = A(t) - A(t) = 0 \quad (8.1.7)$$

$$v(L, t) = u(L, t) - w(L, t) = B(t) - B(t) = 0 \quad (8.1.8)$$

i.e. the function  $v(x, t)$  satisfies homogeneous boundary conditions. The question is, what is the PDE satisfied by  $v(x, t)$ ? To this end, we differentiate (8.1.6) twice with respect to  $x$  and once with respect to  $t$

$$v_x(x, t) = u_x - \frac{1}{L} (B(t) - A(t)) \quad (8.1.9)$$

$$v_{xx} = u_{xx} - 0 = u_{xx} \quad (8.1.10)$$

$$v_t(x, t) = u_t - \frac{x}{L} (\dot{B}(t) - \dot{A}(t)) - \dot{A}(t) \quad (8.1.11)$$

and substitute in (8.1.1)

$$v_t + \dot{A}(t) + \frac{x}{L} (\dot{B}(t) - \dot{A}(t)) = kv_{xx} + S(x, t). \quad (8.1.12)$$

Thus

$$v_t = kv_{xx} + \hat{S}(x, t) \quad (8.1.13)$$

where

$$\hat{S}(x, t) = S(x, t) - \dot{A}(t) - \frac{x}{L} (\dot{B}(t) - \dot{A}(t)). \quad (8.1.14)$$

The initial condition (8.1.4) becomes

$$v(x, 0) = f(x) - A(0) - \frac{x}{L} (B(0) - A(0)) = \hat{f}(x). \quad (8.1.15)$$

Therefore, we have to solve an inhomogeneous PDE (8.1.13) subject to homogeneous boundary conditions(8.1.7)-(8.1.8) and the initial condition (8.1.15).

If the boundary conditions were of a different type, the idea will still be the same. For example, if

$$u(0, t) = A(t) \quad (8.1.16)$$

$$u_x(L, t) = B(t) \quad (8.1.17)$$

then we try

$$w(x, t) = \alpha(t)x + \beta(t). \quad (8.1.18)$$

At  $x = 0$ ,

$$A(t) = w(0, t) = \beta(t)$$

and at  $x = L$ ,

$$B(t) = w_x(L, t) = \alpha(t).$$

Thus

$$w(x, t) = B(t)x + A(t) \quad (8.1.19)$$

satisfies the boundary conditions (8.1.16)-(8.1.17).

Remark: If the boundary conditions are independent of time, we can take the steady state solution as  $w(x)$ .

## Problems

1. For each of the following problems obtain the function  $w(x, t)$  that satisfies the boundary conditions and obtain the PDE

a.

$$\begin{aligned}u_t(x, t) &= ku_{xx}(x, t) + x, & 0 < x < L \\u_x(0, t) &= 1, \\u(L, t) &= t.\end{aligned}$$

b.

$$\begin{aligned}u_t(x, t) &= ku_{xx}(x, t) + x, & 0 < x < L \\u(0, t) &= 1, \\u_x(L, t) &= 1.\end{aligned}$$

c.

$$\begin{aligned}u_t(x, t) &= ku_{xx}(x, t) + x, & 0 < x < L \\u_x(0, t) &= t, \\u_x(L, t) &= t^2.\end{aligned}$$

2. Same as problem 1 for the wave equation

$$u_{tt} - c^2u_{xx} = xt, \quad 0 < x < L$$

subject to each of the boundary conditions

a.

$$u(0, t) = 1 \quad u(L, t) = t$$

b.

$$u_x(0, t) = t \quad u_x(L, t) = t^2$$

c.

$$u(0, t) = 0 \quad u_x(L, t) = t$$

d.

$$u_x(0, t) = 0 \quad u_x(L, t) = 1$$

## 8.2 Method of Eigenfunction Expansions

In this section, we consider the solution of the inhomogeneous heat equation

$$u_t = ku_{xx} + S(x, t), \quad 0 < x < L \quad (8.2.1)$$

$$u(0, t) = 0, \quad (8.2.2)$$

$$u(L, t) = 0, \quad (8.2.3)$$

$$u(x, 0) = f(x). \quad (8.2.4)$$

The solution of the homogeneous PDE leads to the eigenfunctions

$$\phi_n(x) = \sin \frac{n\pi}{L}x, \quad n = 1, 2, \dots \quad (8.2.5)$$

and eigenvalues

$$\lambda_n = \left(\frac{n\pi}{L}\right)^2, \quad n = 1, 2, \dots \quad (8.2.6)$$

Clearly the eigenfunctions depend on the boundary conditions and the PDE. Having the eigenfunctions, we now expand the source term

$$S(x, t) = \sum_{n=1}^{\infty} s_n(t)\phi_n(x), \quad (8.2.7)$$

where

$$s_n(t) = \frac{\int_0^L S(x, t)\phi_n(x)dx}{\int_0^L \phi_n^2(x)dx}. \quad (8.2.8)$$

Let

$$u(x, t) = \sum_{n=1}^{\infty} u_n(t)\phi_n(x), \quad (8.2.9)$$

then

$$f(x) = u(x, 0) = \sum_{n=1}^{\infty} u_n(0)\phi_n(x). \quad (8.2.10)$$

Since  $f(x)$  is known, we have

$$u_n(0) = \frac{\int_0^L f(x)\phi_n(x)dx}{\int_0^L \phi_n^2(x)dx}. \quad (8.2.11)$$

Substitute  $u(x, t)$  from (8.2.9) and its derivatives and  $S(x, t)$  from (8.2.7) into (8.2.1), we have

$$\sum_{n=1}^{\infty} \dot{u}_n(t)\phi_n(x) = \sum_{n=1}^{\infty} (-k\lambda_n)u_n(t)\phi_n(x) + \sum_{n=1}^{\infty} s_n(t)\phi_n(x). \quad (8.2.12)$$

Recall that  $u_{xx}$  gives a series with  $\phi_n''(x)$  which is  $-\lambda_n\phi_n$ , since  $\lambda_n$  are the eigenvalues corresponding to  $\phi_n$ . Combining all three sums in (8.2.12), one has

$$\sum_{n=1}^{\infty} \{\dot{u}_n(t) + k\lambda_n u_n(t) - s_n(t)\} \phi_n(x) = 0. \quad (8.2.13)$$

Therefore

$$\dot{u}_n(t) + k\lambda_n u_n(t) = s_n(t), \quad n = 1, 2, \dots \quad (8.2.14)$$

This inhomogeneous ODE should be combined with the initial condition (8.2.11).

The solution of (8.2.14), (8.2.11) is obtained by the method of variation of parameters (see e.g. Boyce and DiPrima)

$$u_n(t) = u_n(0)e^{-\lambda_n kt} + \int_0^t s_n(\tau)e^{-\lambda_n k(t-\tau)} d\tau. \quad (8.2.15)$$

It is easy to see that  $u_n(t)$  above satisfies (8.2.11) and (8.2.14). We summarize the solution by (8.2.9), (8.2.15), (8.2.11) and (8.2.8).

Example

$$u_t = u_{xx} + 1, \quad 0 < x < 1 \quad (8.2.16)$$

$$u_x(0, t) = 2, \quad (8.2.17)$$

$$u(1, t) = 0, \quad (8.2.18)$$

$$u(x, 0) = x(1 - x). \quad (8.2.19)$$

The function  $w(x, t)$  to satisfy the inhomogeneous boundary conditions is

$$w(x, t) = 2x - 2. \quad (8.2.20)$$

The function

$$v(x, t) = u(x, t) - w(x, t) \quad (8.2.21)$$

satisfies the following PDE

$$v_t = v_{xx} + 1, \quad (8.2.22)$$

since  $w_t = w_{xx} = 0$ . The initial condition is

$$v(x, 0) = x(1 - x) - (2x - 2) = x(1 - x) + 2(1 - x) = (x + 2)(1 - x) \quad (8.2.23)$$

and the homogeneous boundary conditions are

$$v_x(0, t) = 0, \quad (8.2.24)$$

$$v(1, t) = 0. \quad (8.2.25)$$

The eigenfunctions  $\phi_n(x)$  and eigenvalues  $\lambda_n$  satisfy

$$\phi_n''(x) + \lambda_n \phi_n = 0, \quad (8.2.26)$$

$$\phi_n'(0) = 0, \quad (8.2.27)$$

$$\phi_n(1) = 0. \quad (8.2.28)$$

Thus

$$\phi_n(x) = \cos\left(n - \frac{1}{2}\right)\pi x, \quad n = 1, 2, \dots \quad (8.2.29)$$



$$\lambda_n = \left[ \left( n - \frac{1}{2} \right) \pi \right]^2. \quad (8.2.30)$$

Expanding  $S(x, t) = 1$  and  $v(x, t)$  in these eigenfunctions we have

$$1 = \sum_{n=1}^{\infty} s_n \phi_n(x) \quad (8.2.31)$$

where

$$s_n = \frac{\int_0^1 1 \cdot \cos\left(n - \frac{1}{2}\right)\pi x dx}{\int_0^1 \cos^2\left(n - \frac{1}{2}\right)\pi x dx} = \frac{4(-1)^{n-1}}{(2n-1)\pi}, \quad (8.2.32)$$

and

$$v(x, t) = \sum_{n=1}^{\infty} v_n(t) \cos\left(n - \frac{1}{2}\right)\pi x. \quad (8.2.33)$$

The partial derivatives of  $v(x, t)$  required are

$$v_t(x, t) = \sum_{n=1}^{\infty} \dot{v}_n(t) \cos\left(n - \frac{1}{2}\right)\pi x, \quad (8.2.34)$$

$$v_{xx}(x, t) = - \sum_{n=1}^{\infty} \left[ \left( n - \frac{1}{2} \right) \pi \right]^2 v_n(t) \cos\left(n - \frac{1}{2}\right)\pi x. \quad (8.2.35)$$

Thus, upon substituting (8.2.34), (8.2.35) and (8.2.31) into (8.2.22), we get

$$\dot{v}_n(t) + \left[ \left( n - \frac{1}{2} \right) \pi \right]^2 v_n(t) = s_n. \quad (8.2.36)$$

The initial condition  $v_n(0)$  is given by the eigenfunction expansion of  $v(x, 0)$ , i.e.

$$(x+2)(1-x) = \sum_{n=1}^{\infty} v_n(0) \cos\left(n - \frac{1}{2}\right)\pi x \quad (8.2.37)$$

so

$$v_n(0) = \frac{\int_0^1 (x+2)(1-x) \cos\left(n - \frac{1}{2}\right)\pi x dx}{\int_0^1 \cos^2\left(n - \frac{1}{2}\right)\pi x dx}. \quad (8.2.38)$$

The solution of (8.2.36) is

$$v_n(t) = v_n(0)e^{-\left[\left(n - \frac{1}{2}\right)\pi\right]^2 t} + s_n \int_0^t e^{-\left[\left(n - \frac{1}{2}\right)\pi\right]^2 (t-\tau)} d\tau$$

Performing the integration

$$v_n(t) = v_n(0)e^{-\left[\left(n - \frac{1}{2}\right)\pi\right]^2 t} + s_n \frac{1 - e^{-\left[\left(n - \frac{1}{2}\right)\pi\right]^2 t}}{\left[\left(n - \frac{1}{2}\right)\pi\right]^2} \quad (8.2.39)$$

where  $v_n(0)$ ,  $s_n$  are given by (8.2.38) and (8.2.32) respectively.

## Problems

1. Solve the heat equation

$$u_t = ku_{xx} + x, \quad 0 < x < L$$

subject to the initial condition

$$u(x, 0) = x(L - x)$$

and each of the boundary conditions

a.

$$\begin{aligned}u_x(0, t) &= 1, \\u(L, t) &= t.\end{aligned}$$

b.

$$\begin{aligned}u(0, t) &= 1, \\u_x(L, t) &= 1.\end{aligned}$$

c.

$$\begin{aligned}u_x(0, t) &= t, \\u_x(L, t) &= t^2.\end{aligned}$$

2. Solve the heat equation

$$u_t = u_{xx} + e^{-t}, \quad 0 < x < \pi, \quad t > 0,$$

subject to the initial condition

$$u(x, 0) = \cos 2x, \quad 0 < x < \pi,$$

and the boundary condition

$$u_x(0, t) = u_x(\pi, t) = 0.$$

### 8.3 Forced Vibrations

In this section we solve the inhomogeneous wave equation in two dimensions describing the forced vibrations of a membrane.

$$u_{tt} = c^2 \nabla^2 u + S(x, y, t) \quad (8.3.1)$$

subject to the boundary condition

$$u(x, y, t) = 0, \quad \text{on the boundary,} \quad (8.3.2)$$

and initial conditions

$$u(x, y, 0) = \alpha(x, y), \quad (8.3.3)$$

$$u_t(x, y, 0) = \beta(x, y). \quad (8.3.4)$$

Since the boundary condition is homogeneous, we can expand the solution  $u(x, y, t)$  and the forcing term  $S(x, y, t)$  in terms of the eigenfunctions  $\phi_n(x, y)$ , i.e.

$$u(x, y, t) = \sum_{i=1}^{\infty} u_i(t) \phi_i(x, y), \quad (8.3.5)$$

$$S(x, y, t) = \sum_{i=1}^{\infty} s_i(t) \phi_i(x, y), \quad (8.3.6)$$

where

$$\nabla^2 \phi_i = -\lambda_i \phi_i, \quad (8.3.7)$$

$$\phi_i = 0, \quad \text{on the boundary,} \quad (8.3.8)$$

and

$$s_i(t) = \frac{\iint S(x, y, t) \phi_i(x, y) dx dy}{\iint \phi_i^2(x, y) dx dy}. \quad (8.3.9)$$

Substituting (8.3.5), (8.3.6) into (8.3.1) we have

$$\sum_{i=1}^{\infty} \ddot{u}_i(t) \phi_i(x, y) = c^2 \sum_{i=1}^{\infty} u_i(t) \nabla^2 \phi_i + \sum_{i=1}^{\infty} s_i(t) \phi_i(x, y).$$

Using (8.3.7) and combining all the sums, we get an ODE for the coefficients  $u_i(t)$ ,

$$\ddot{u}_i(t) + c^2 \lambda_i u_i(t) = s_i(t). \quad (8.3.10)$$

The solution can be found in any ODE book,

$$u_i(t) = c_1 \cos c\sqrt{\lambda_i}t + c_2 \sin c\sqrt{\lambda_i}t + \int_0^t s_i(\tau) \frac{\sin c\sqrt{\lambda_i}(t-\tau)}{c\sqrt{\lambda_i}} d\tau. \quad (8.3.11)$$

The initial conditions (8.3.3)-(8.3.4) imply

$$u_i(0) = c_1 = \frac{\iint \alpha(x, y) \phi_i(x, y) dx dy}{\iint \phi_i^2(x, y) dx dy}, \quad (8.3.12)$$

$$\dot{u}_i(0) = c_2 c \sqrt{\lambda_i} = \frac{\iint \beta(x, y) \phi_i(x, y) dx dy}{\iint \phi_i^2(x, y) dx dy}. \quad (8.3.13)$$

Equations (8.3.12)-(8.3.13) can be solved for  $c_1$  and  $c_2$ . Thus the solution  $u(x, y, t)$  is given by (8.3.5) with  $u_i(t)$  given by (8.3.11)-(8.3.13) and  $s_i(t)$  are given by (8.3.9).

### 8.3.1 Periodic Forcing

If the forcing  $S(x, y, t)$  is a periodic function in time, we have an interesting case. Suppose

$$S(x, y, t) = \sigma(x, y) \cos \omega t, \quad (8.3.1.1)$$

then by (8.3.9) we have

$$s_i(t) = \sigma_i \cos \omega t, \quad (8.3.1.2)$$

where

$$\sigma_i(t) = \frac{\int \int \sigma(x, y) \phi_i(x, y) dx dy}{\int \int \phi_i^2(x, y) dx dy}. \quad (8.3.1.3)$$

The ODE for the unknown  $u_i(t)$  becomes

$$\ddot{u}_i(t) + c^2 \lambda_i u_i(t) = \sigma_i \cos \omega t. \quad (8.3.1.4)$$

In this case the particular solution of the nonhomogeneous is

$$\frac{\sigma_i}{c^2 \lambda_i - \omega^2} \cos \omega t \quad (8.3.1.5)$$

and thus

$$u_i(t) = c_1 \cos c\sqrt{\lambda_i}t + c_2 \sin c\sqrt{\lambda_i}t + \frac{\sigma_i}{c^2 \lambda_i - \omega^2} \cos \omega t. \quad (8.3.1.6)$$

The amplitude  $u_i(t)$  of the mode  $\phi_i(x, y)$  is decomposed to a vibration at the natural frequency  $c\sqrt{\lambda_i}$  and a vibration at the forcing frequency  $\omega$ . What happens if  $\omega$  is one of the natural frequencies, i.e.

$$\omega = c\sqrt{\lambda_i} \quad \text{for some } i. \quad (8.3.1.7)$$

Then the denominator in (8.3.1.6) vanishes. The particular solution should not be (8.3.1.5) but rather

$$\frac{\sigma_i}{2\omega} t \sin \omega t. \quad (8.3.1.8)$$

The amplitude is growing linearly in  $t$ . This is called resonance.

## Problems

1. Consider a vibrating string with time dependent forcing

$$u_{tt} - c^2 u_{xx} = S(x, t), \quad 0 < x < L$$

subject to the initial conditions

$$u(x, 0) = f(x),$$

$$u_t(x, 0) = 0,$$

and the boundary conditions

$$u(0, t) = u(L, t) = 0.$$

- a. Solve the initial value problem.  
b. Solve the initial value problem if  $S(x, t) = \cos \omega t$ . For what values of  $\omega$  does resonance occur?

2. Consider the following damped wave equation

$$u_{tt} - c^2 u_{xx} + \beta u_t = \cos \omega t, \quad 0 < x < \pi,$$

subject to the initial conditions

$$u(x, 0) = f(x),$$

$$u_t(x, 0) = 0,$$

and the boundary conditions

$$u(0, t) = u(\pi, t) = 0.$$

Solve the problem if  $\beta$  is small ( $0 < \beta < 2c$ ).

3. Solve the following

$$u_{tt} - c^2 u_{xx} = S(x, t), \quad 0 < x < L$$

subject to the initial conditions

$$u(x, 0) = f(x),$$

$$u_t(x, 0) = 0,$$

and each of the following boundary conditions

a.

$$u(0, t) = A(t) \quad u(L, t) = B(t)$$

b.

$$u(0, t) = 0 \quad u_x(L, t) = 0$$

c.

$$u_x(0, t) = A(t) \quad u(L, t) = 0.$$

4. Solve the wave equation

$$u_{tt} - c^2 u_{xx} = xt, \quad 0 < x < L,$$

subject to the initial conditions

$$u(x, 0) = \sin x$$

$$u_t(x, 0) = 0$$

and each of the boundary conditions

a.

$$u(0, t) = 1,$$

$$u(L, t) = t.$$

b.

$$u_x(0, t) = t,$$

$$u_x(L, t) = t^2.$$

c.

$$u(0, t) = 0,$$

$$u_x(L, t) = t.$$

d.

$$u_x(0, t) = 0,$$

$$u_x(L, t) = 1.$$

5. Solve the wave equation

$$u_{tt} - u_{xx} = 1, \quad 0 < x < L,$$

subject to the initial conditions

$$u(x, 0) = f(x)$$

$$u_t(x, 0) = g(x)$$

and the boundary conditions

$$u(0, t) = 1,$$

$$u_x(L, t) = B(t).$$

## 8.4 Poisson's Equation

In this section we solve Poisson's equation subject to homogeneous and nonhomogeneous boundary conditions. In the first case we can use the method of eigenfunction expansion in one dimension and two.

### 8.4.1 Homogeneous Boundary Conditions

Consider Poisson's equation

$$\nabla^2 u = S, \quad (8.4.1.1)$$

subject to homogeneous boundary condition, e.g.

$$u = 0, \quad \text{on the boundary.} \quad (8.4.1.2)$$

The problem can be solved by the method of eigenfunction expansion. To be specific we suppose the domain is a rectangle of length  $L$  and height  $H$ , see figure 55.

We first consider the one dimensional eigenfunction expansion, i.e.

$$\phi_n(x) = \sin \frac{n\pi}{L}x, \quad (8.4.1.3)$$

and

$$u(x, y) = \sum_{n=1}^{\infty} u_n(y) \sin \frac{n\pi}{L}x. \quad (8.4.1.4)$$

Substitution in Poisson's equation, we get

$$\sum_{n=1}^{\infty} \left[ u_n''(y) - \left( \frac{n\pi}{L} \right)^2 u_n(y) \right] \sin \frac{n\pi}{L}x = \sum_{n=1}^{\infty} s_n(y) \sin \frac{n\pi}{L}x, \quad (8.4.1.5)$$

where

$$s_n(y) = \frac{2}{L} \int_0^L S(x, y) \sin \frac{n\pi}{L}x dx. \quad (8.4.1.6)$$

The other boundary conditions lead to

$$u_n(0) = 0, \quad (8.4.1.7)$$

$$u_n(H) = 0. \quad (8.4.1.8)$$

So we end up with a boundary value problem for  $u_n(y)$ , i.e.

$$u_n''(y) - \left( \frac{n\pi}{L} \right)^2 u_n(y) = s_n(y), \quad (8.4.1.9)$$

subject to (8.4.1.7)-(8.4.1.8).

It requires a lengthy algebraic manipulation to show that the solution is

$$u_n(y) = \frac{\sinh \frac{n\pi(H-y)}{L}}{-\frac{n\pi}{L} \sinh \frac{n\pi H}{L}} \int_0^y s_n(\xi) \sinh \frac{n\pi}{L} \xi d\xi + \frac{\sinh \frac{n\pi y}{L}}{-\frac{n\pi}{L} \sinh \frac{n\pi H}{L}} \int_y^H s_n(\xi) \sinh \frac{n\pi}{L} (H - \xi) d\xi. \quad (8.4.1.10)$$

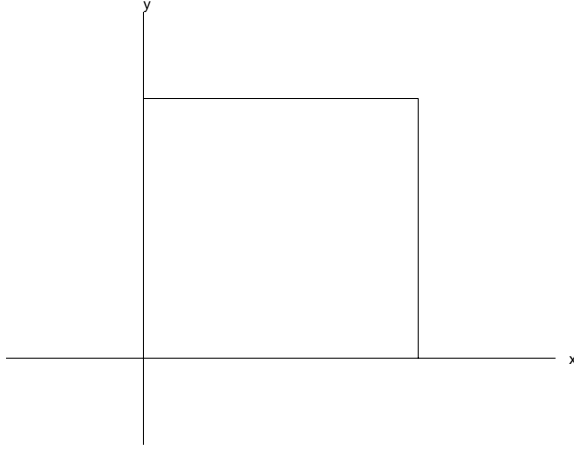

Figure 55: Rectangular domain

So the solution is given by (8.4.1.4) with  $u_n(y)$  and  $s_n(y)$  given by (8.4.1.10) and (8.4.1.6) respectively.

Another approach, related to the first, is the use of two dimensional eigenfunctions. In the example,

$$\phi_{nm} = \sin \frac{n\pi}{L}x \sin \frac{m\pi}{H}y, \quad (8.4.1.11)$$

$$\lambda_{nm} = \left(\frac{n\pi}{L}\right)^2 + \left(\frac{m\pi}{H}\right)^2. \quad (8.4.1.12)$$

We then write the solution

$$u(x, y) = \sum_{n=1}^{\infty} \sum_{m=1}^{\infty} u_{nm} \phi_{nm}(x, y). \quad (8.4.1.13)$$

Substituting (8.4.1.13) into the equation, we get

$$\sum_{n=1}^{\infty} \sum_{m=1}^{\infty} (-u_{nm}) \lambda_{nm} \sin \frac{n\pi}{L}x \sin \frac{m\pi}{H}y = S(x, y). \quad (8.4.1.14)$$

Therefore  $-u_{nm} \lambda_{nm}$  are the coefficients of the double Fourier series expansion of  $S(x, y)$ , that is

$$u_{nm} = \frac{\int_0^L \int_0^H S(x, y) \sin \frac{n\pi}{L}x \sin \frac{m\pi}{H}y dy dx}{-\lambda_{nm} \int_0^L \int_0^H \sin^2 \frac{n\pi}{L}x \sin^2 \frac{m\pi}{H}y dy dx}. \quad (8.4.1.15)$$

This double series may converge slower than the previous solution.



### 8.4.2 Inhomogeneous Boundary Conditions

The problem is then

$$\nabla^2 u = S, \quad (8.4.2.1)$$

subject to inhomogeneous boundary condition, e.g.

$$u = \alpha, \quad \text{on the boundary.} \quad (8.4.2.2)$$

The eigenvalues  $\lambda_i$  and the eigenfunctions  $\phi_i$  satisfy

$$\nabla^2 \phi_i = -\lambda_i \phi_i, \quad (8.4.2.3)$$

$$\phi_i = 0, \quad \text{on the boundary.} \quad (8.4.2.4)$$

Since the boundary condition (8.4.2.2) is not homogeneous, we cannot differentiate the infinite series term by term. But note that the coefficients  $u_n$  of the expansion are given by:

$$u_n = \frac{\int \int u(x, y) \phi_n(x, y) dx dy}{\int \int \phi_n^2(x, y) dx dy} = -\frac{1}{\lambda_n} \frac{\int \int u \nabla^2 \phi_n dx dy}{\int \int \phi_n^2 dx dy}. \quad (8.4.2.5)$$

Using Green's formula, i.e.

$$\int \int u \nabla^2 \phi_n dx dy = \int \int \phi_n \nabla^2 u dx dy + \oint (u \nabla \phi_n - \phi_n \nabla u) \cdot \vec{n} ds,$$

substituting from (8.4.2.1), (8.4.2.2) and (8.4.2.4)

$$= \int \int \phi_n S dx dy + \oint \alpha \nabla \phi_n \cdot \vec{n} ds \quad (8.4.2.6)$$

Therefore the coefficients  $u_n$  become (combining (8.4.2.5)-(8.4.2.6))

$$u_n = -\frac{1}{\lambda_n} \frac{\int \int S \phi_n dx dy + \oint \alpha \nabla \phi_n \cdot \vec{n} ds}{\int \int \phi_n^2 dx dy}. \quad (8.4.2.7)$$

If  $\alpha = 0$  we get (8.4.1.15). The case  $\lambda = 0$  will not be discussed here.

We now give another way to solve the same problem (8.4.2.1)-(8.4.2.2). Since the problem is linear, we can write

$$u = v + w \quad (8.4.2.8)$$

where  $v$  solves Poisson's equation with homogeneous boundary conditions (see the previous subsection) and  $w$  solves Laplace's equation with the nonhomogeneous boundary conditions (8.4.2.2).

## Problems

1. Solve

$$\nabla^2 u = S(x, y), \quad 0 < x < L, \quad 0 < y < H,$$

a.

$$u(0, y) = u(L, y) = 0$$

$$u(x, 0) = u(x, H) = 0$$

Use a Fourier sine series in  $y$ .

b.

$$u(0, y) = 0 \quad u(L, y) = 1$$

$$u(x, 0) = u(x, H) = 0$$

Hint: Do NOT reduce to homogeneous boundary conditions.

c.

$$u_x(0, y) = u_x(L, y) = 0$$

$$u_y(x, 0) = u_y(x, H) = 0$$

In what situations are there solutions?

2. Solve the following Poisson's equation

$$\nabla^2 u = e^{2y} \sin x, \quad 0 < x < \pi, \quad 0 < y < L,$$

$$u(0, y) = u(\pi, y) = 0,$$

$$u(x, 0) = 0,$$

$$u(x, L) = f(x).$$

## SUMMARY

Nonhomogeneous problems

1. Find a function  $w$  that satisfies the inhomogeneous boundary conditions (except for Poisson's equation).

2. Let  $v = u - w$ , then  $v$  satisfies an inhomogeneous PDE with homogeneous boundary conditions.

3. Solve the homogeneous equation with homogeneous boundary conditions to obtain eigenvalues and eigenfunctions.

4. Expand the solution  $v$ , the right hand side (source/sink) and initial condition(s) in eigenfunctions series.

5. Solve the resulting inhomogeneous ODE.

$$\dot{u}_n(t) + k\lambda_n u_n(t) = s_n(t), \quad n = 1, 2, \dots$$

$$u_n(0) = \text{given}$$

$$u_n(t) = u_n(0)e^{-\lambda_n kt} + \int_0^t s_n(\tau)e^{-\lambda_n k(t-\tau)} d\tau.$$

$$\ddot{u}_n(t) + c^2\lambda_n u_n(t) = s_n(t), \quad n = 1, 2, \dots$$

$$u_n(0) = \text{given}$$

$$\dot{u}_n(0) = \text{given}$$

$$u_n(t) = u_n(0) \cos c\sqrt{\lambda_n}t + \frac{\dot{u}_n(0)}{c\sqrt{\lambda_n}} \sin c\sqrt{\lambda_n}t + \int_0^t s_n(\tau) \frac{\sin c\sqrt{\lambda_n}(t-\tau)}{c\sqrt{\lambda_n}} d\tau.$$

$$u_n''(y) - \left(\frac{n\pi}{L}\right)^2 u_n(y) = s_n(y),$$

$$u_n(0) = 0,$$

$$u_n(H) = 0.$$

$$u_n(y) = \frac{\sinh \frac{n\pi(H-y)}{L}}{-\frac{n\pi}{L} \sinh \frac{n\pi H}{L}} \int_0^y s_n(\xi) \sinh \frac{n\pi}{L} \xi d\xi + \frac{\sinh \frac{n\pi y}{L}}{-\frac{n\pi}{L} \sinh \frac{n\pi H}{L}} \int_y^H s_n(\xi) \sinh \frac{n\pi}{L} (H-\xi) d\xi.$$

## 9 Fourier Transform Solutions of PDEs

In this chapter we discuss another method to solve PDEs. This method extends the separation of variables to infinite domain.

### 9.1 Motivation

We start with an example to motivate the Fourier transform method.

#### Example

Solve the heat equation

$$u_t = ku_{xx}, \quad -\infty < x < \infty, \quad (9.1.1)$$

subject to the initial condition

$$u(x, 0) = f(x). \quad (9.1.2)$$

Using the method of separation of variables we have

$$u(x, t) = X(x)T(t), \quad (9.1.3)$$

and the two ODEs are

$$\dot{T}(t) = -k\lambda T(t), \quad (9.1.4)$$

$$X''(x) = -\lambda X(x). \quad (9.1.5)$$

Notice that we do not have any boundary conditions, but we clearly require the solution to be bounded as  $x$  approaches  $\pm\infty$ . Using the boundedness, we can immediately eliminate the possibility that  $\lambda < 0$  (exercise). Any  $\lambda \geq 0$  will do. This is called a continuous spectrum. In the case of finite domain, we always have a discrete spectrum. The principle of superposition will take the form of an integral (instead of an infinite series):

$$u(x, t) = \int_0^\infty \{C(\lambda) \cos \sqrt{\lambda}x + D(\lambda) \sin \sqrt{\lambda}x\} e^{-k\lambda t} d\lambda.$$

Let  $\lambda = \omega^2$ , then

$$u(x, t) = \int_0^\infty \{A(\omega) \cos \omega x + B(\omega) \sin \omega x\} e^{-k\omega^2 t} d\omega. \quad (9.1.6)$$

The initial condition leads to

$$f(x) = \int_0^\infty \{A(\omega) \cos \omega x + B(\omega) \sin \omega x\} d\omega. \quad (9.1.7)$$

We can rewrite these integral as follows

$$u(x, t) = \int_{-\infty}^\infty K(\omega) e^{i\omega x} e^{-k\omega^2 t} d\omega, \quad (9.1.8)$$

$$f(x) = \int_{-\infty}^\infty K(\omega) e^{i\omega x} d\omega, \quad (9.1.9)$$

by representing the trigonometric functions as complex exponentials and combining the resulting integrals.

In the next section, we define Fourier transform and show how to obtain the solution to the heat conduction and wave equations.

## 9.2 Fourier Transform pair

Let

$$F(\omega) = \frac{1}{2\pi} \int_{-\infty}^{\infty} f(x)e^{-i\omega x} dx \quad (9.2.1)$$

be the Fourier transform of  $f(x)$ . The inverse Fourier transform is defined by

$$f(x) = \int_{-\infty}^{\infty} F(\omega)e^{i\omega x} d\omega. \quad (9.2.2)$$

Actually the left hand side should be  $\frac{f(x_+) + f(x_-)}{2}$ .

In order to solve the heat equation, we need the Inverse Fourier transform of a Gaussian:

$$G(\omega) = e^{-\alpha\omega^2}. \quad (9.2.3)$$

$$g(x) = \int_{-\infty}^{\infty} e^{-\alpha\omega^2} e^{i\omega x} d\omega = \int_{-\infty}^{\infty} e^{-\alpha\omega^2 + i\omega x} d\omega. \quad (9.2.4)$$

We will show that (next 2 pages)

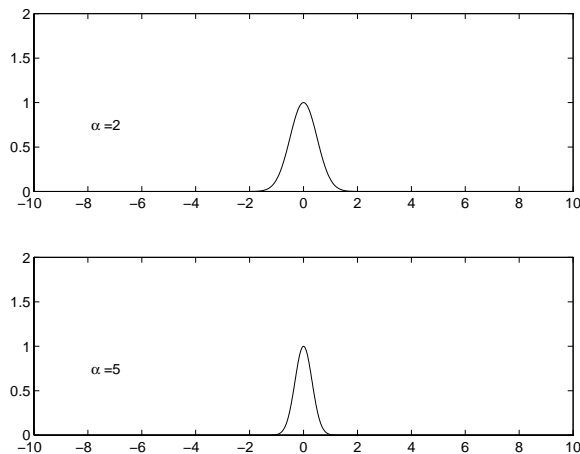

Figure 56: Plot  $G(\omega)$  for  $\alpha = 2$  and  $\alpha = 5$

$$g(x) = \sqrt{\frac{\pi}{\alpha}} e^{-\frac{x^2}{4\alpha}}. \quad (9.2.5)$$

This function is also a Gaussian. The parameter  $\alpha$  controls the spread of the bell. If  $\alpha$  is large  $G(\omega)$  is sharply peaked, but then  $\frac{1}{\alpha}$  is small and  $g(x)$  is broadly spread, see Figures 56-57.

$$\begin{aligned} g(x) &= \int_{-\infty}^{\infty} e^{-\alpha\omega^2 + i\omega x} d\omega \\ &= \int_{-\infty}^{\infty} e^{-\alpha(\omega^2 - i\frac{x}{\alpha}\omega)} d\omega \end{aligned}$$

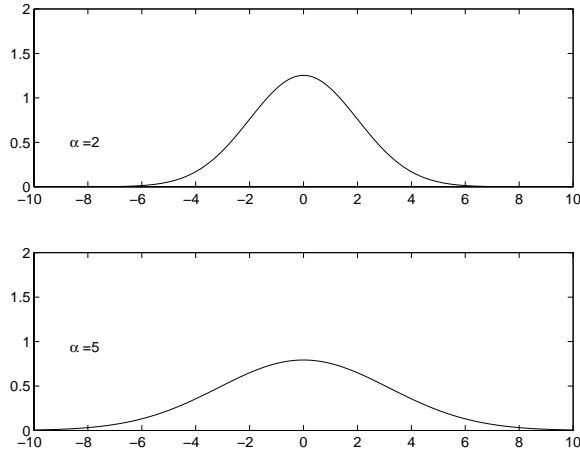

Figure 57: Plot  $g(x)$  for  $\alpha = 2$  and  $\alpha = 5$

complete the squares

$$= e^{-\frac{x^2}{4\alpha}} \int_{-\infty}^{\infty} e^{-\alpha(\omega - i\frac{x}{2\alpha})^2} d\omega.$$

Let

$$\begin{aligned} z &= \sqrt{\alpha}(\omega - i\frac{x}{2\alpha}) \\ dz &= \sqrt{\alpha}d\omega \\ &= e^{-\frac{x^2}{4\alpha}} \frac{1}{\sqrt{\alpha}} \int_{-\infty - i\frac{x}{2\alpha}}^{\infty - i\frac{x}{2\alpha}} e^{-z^2} dz \end{aligned}$$

From complex variables

$$= e^{-\frac{x^2}{4\alpha}} \frac{1}{\sqrt{\alpha}} \int_{-\infty}^{\infty} e^{-z^2} dz$$

The trick to compute the integral is as follows: if

$$I = \int_{-\infty}^{\infty} e^{-z^2} dz$$

then

$$I^2 = \int_{-\infty}^{\infty} e^{-x^2} dx \int_{-\infty}^{\infty} e^{-y^2} dy = \int_{-\infty}^{\infty} \int_{-\infty}^{\infty} e^{-(x^2+y^2)} dy dx.$$

Use polar coordinates

$$\begin{aligned} x^2 + y^2 &= r^2 \\ dx dy &= r dr d\theta \\ I^2 &= \int_0^{2\pi} \left( \int_0^{\infty} e^{-r^2} r dr \right) d\theta. \end{aligned}$$

The integral in  $r$  is easy (let  $r^2 = s$ ,  $2r dr = ds$ ), therefore

$$I^2 = \frac{1}{2} \cdot 2\pi = \pi.$$

Thus

$$g(x) = e^{-\frac{x^2}{4\alpha}} \frac{1}{\sqrt{\alpha}} \sqrt{\pi} \quad (9.2.6)$$

which is (9.2.5)

## Problems

1. Show that the Fourier transform is a linear operator, i. e.

$$\mathcal{F}(c_1f(x) + c_2g(x)) = c_1\mathcal{F}(f(x)) + c_2\mathcal{F}(g(x)) .$$

2. If  $F(\omega)$  is the Fourier transform of  $f(x)$ , show that the inverse Fourier transform of  $e^{-i\omega\beta}F(\omega)$  is  $f(x - \beta)$ . This is known as the shift theorem.

3. Determine the Fourier transform of

$$f(x) = \begin{cases} 0 & |x| > a \\ 1 & |x| < a . \end{cases}$$

4. Determine the Fourier transform of

$$f(x) = \int_{-\infty}^x \phi(t)dt,$$

assuming that  $\int_{-\infty}^{\infty} \phi(t)dt = 0$ .

5. Prove the scaling theorem

$$\mathcal{F}(f(ax)) = \frac{1}{|a|} F\left(\frac{\omega}{a}\right)$$

where

$$F(\omega) = \mathcal{F}(f(x)) .$$

6. If  $F(\omega)$  is the Fourier transform of  $f(x)$ , prove the translation theorem

$$\mathcal{F}(e^{iax}f(x)) = F(\omega - a).$$



### 9.3 Heat Equation

We have seen that the solution of the heat equation

$$u_t = ku_{xx}, \quad -\infty < x < \infty, \quad (9.3.1)$$

$$u(x, 0) = f(x), \quad (9.3.2)$$

is given by

$$u(x, t) = \int_{-\infty}^{\infty} c(\omega) e^{i\omega x - k\omega^2 t} d\omega, \quad (9.3.3)$$

where

$$f(x) = \int_{-\infty}^{\infty} c(\omega) e^{i\omega x} d\omega. \quad (9.3.4)$$

Therefore  $c(\omega)$  is the Fourier transform of  $f(x)$ , i. e.

$$c(\omega) = \frac{1}{2\pi} \int_{-\infty}^{\infty} f(x) e^{-i\omega x} dx. \quad (9.3.5)$$

Thus, the solution is given by (9.3.3) and (9.3.5). Let's simplify this by substituting (9.3.5) into (9.3.3)

$$u(x, t) = \int_{-\infty}^{\infty} \left[ \frac{1}{2\pi} \int_{-\infty}^{\infty} f(\xi) e^{-i\omega \xi} d\xi \right] e^{i\omega x - k\omega^2 t} d\omega.$$

Interchange the integration, we have

$$u(x, t) = \frac{1}{2\pi} \int_{-\infty}^{\infty} f(\xi) \left[ \int_{-\infty}^{\infty} e^{-k\omega^2 t + i\omega(x-\xi)} d\omega \right] d\xi.$$

Let

$$g(x, t) = \int_{-\infty}^{\infty} e^{-k\omega^2 t} e^{i\omega x} d\omega, \quad (9.3.6)$$

then

$$u(x, t) = \frac{1}{2\pi} \int_{-\infty}^{\infty} f(\xi) g(x - \xi, t) d\xi.$$

The integral in (9.3.6) is found previously (a Gaussian) for  $\alpha = kt$ ,

$$g(x, t) = \sqrt{\frac{\pi}{kt}} e^{-\frac{x^2}{4kt}}, \quad (9.3.7)$$

thus the solution is

$$u(x, t) = \frac{1}{\sqrt{4\pi kt}} \int_{-\infty}^{\infty} f(\xi) e^{-\frac{(x-\xi)^2}{4kt}} d\xi. \quad (9.3.8)$$

The function

$$G(x, t; \xi, 0) = \frac{1}{\sqrt{4\pi kt}} e^{-\frac{(x-\xi)^2}{4kt}} \quad (9.3.9)$$

is called the influence function. It measures the effect of the initial temperature  $f$  at point  $\xi$  on the temperature  $u$  at later time  $t$  and location  $x$ . The spread of influence is small when  $t$  is small ( $t$  is in denominator!!). The spread of influence increases with time.

Example

Solve the heat equation

$$u_t = ku_{xx}, \quad -\infty < x < \infty, \quad (9.3.10)$$

subject to the initial condition

$$u(x, 0) = f(x) = \begin{cases} 0 & x < 0 \\ 100 & x > 0 \end{cases}. \quad (9.3.11)$$

The solution is

$$u(x, t) = \frac{100}{\sqrt{4\pi kt}} \int_0^\infty e^{-\frac{(x-\xi)^2}{4kt}} d\xi. \quad (9.3.12)$$

Note that the lower limit of the integral is zero since  $f$  is zero for negative argument. This integral can be written in terms of the error function defined by

$$erf(z) = \frac{2}{\sqrt{\pi}} \int_0^z e^{-\xi^2} d\xi. \quad (9.3.13)$$

The function vanishes at  $x = 0$  and monotonically increases to unity. The graph of the function is given in Figure 58. Using the transformation

$$z = \frac{\xi - x}{\sqrt{4kt}}, \quad (9.3.14)$$

the integral (9.3.12) becomes

$$u(x, t) = \frac{100}{\sqrt{\pi}} \int_{-\frac{x}{\sqrt{4kt}}}^\infty e^{-z^2} dz = \frac{100}{\sqrt{\pi}} \int_0^\infty e^{-z^2} dz + \frac{100}{\sqrt{\pi}} \int_{-\frac{x}{\sqrt{4kt}}}^0 e^{-z^2} dz. \quad (9.3.15)$$

Since

$$\int_0^\infty e^{-z^2} dz = \frac{\sqrt{\pi}}{2}, \quad (9.3.16)$$

we get when substituting  $\zeta = -z$  in the second integral

$$u(x, t) = 50 + \frac{100}{\sqrt{\pi}} \int_0^{\frac{x}{\sqrt{4kt}}} e^{-\zeta^2} d\zeta \quad (9.3.17)$$

after changing the variables on the last integral in (9.3.15). The solution of (9.3.10)–(9.3.11) is then given by

$$u(x, t) = 50 \left( 1 + erf \left( \frac{x}{\sqrt{4kt}} \right) \right). \quad (9.3.18)$$

In order to be able to solve other PDEs, we list in the next chapter several results concerning Fourier transform and its inverse.

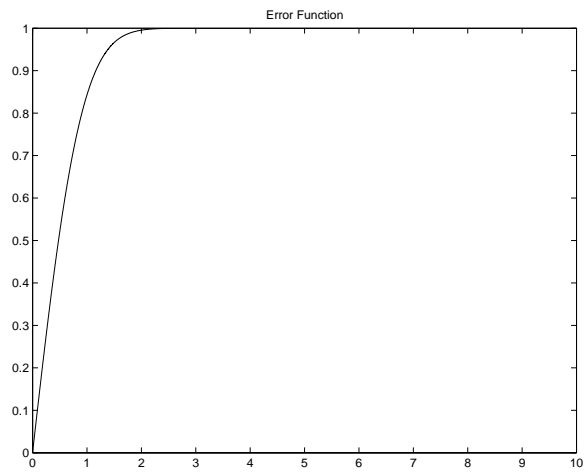

Figure 58: Plot of the error function  $erf(x)$

## Problems

1. Use Fourier transform to solve the heat equation

$$\begin{aligned}u_t &= u_{xx} + u, & -\infty < x < \infty, & \quad t > 0, \\u(x, 0) &= f(x).\end{aligned}$$

## 9.4 Fourier Transform of Derivatives

In this chapter, we show how a PDE is transformed to an ODE by the Fourier transform. We can show that a Fourier transform of time derivatives are given as time derivatives of the Fourier transform. Fourier transform of spatial derivatives are multiples of the Fourier transform of the function. We use  $\mathcal{F}$  to denote the Fourier transform operator.

$$\mathcal{F}\left(\frac{\partial u}{\partial t}\right) = \frac{\partial}{\partial t}\mathcal{F}(u) \quad (9.4.1)$$

$$\mathcal{F}\left(\frac{\partial u}{\partial x}\right) = i\omega\mathcal{F}(u) \quad (9.4.2)$$

$$\mathcal{F}\left(\frac{\partial^2 u}{\partial x^2}\right) = -\omega^2\mathcal{F}(u) \quad (9.4.3)$$

These can be obtained by definition of Fourier transform and left as an exercise. As a result

$$u_t(x, t) = ku_{xx}(x, t) \quad (9.4.4)$$

becomes

$$\frac{\partial}{\partial t}U(\omega, t) = -k\omega^2U(\omega, t) \quad (9.4.5)$$

where  $U(\omega, t)$  is the Fourier transform of  $u(x, t)$ . Equation (9.4.5) is a first order ODE, for which we know that the solution is

$$U(\omega, t) = C(\omega)e^{-k\omega^2t} \quad (9.4.6)$$

The “constant”  $c(\omega)$  can be found by transforming the initial condition

$$u(x, 0) = f(x) \quad (9.4.7)$$

i. e.

$$U(\omega, 0) = F(\omega). \quad (9.4.8)$$

Therefore, combining (9.4.6) and (9.4.8) we get

$$c(\omega) = F(\omega). \quad (9.4.9)$$

Another important result in solving PDEs using the Fourier transform is called the convolution theorem.

*Convolution Theorem* Let  $f(x)$ ,  $g(x)$  be functions whose Fourier transform is  $F(\omega)$ ,  $G(\omega)$  respectively. Let  $h(x)$  having Fourier transform  $H(\omega) = F(\omega)G(\omega)$ , then

$$\begin{aligned} h(x) &= \int_{-\infty}^{\infty} H(\omega)e^{i\omega x}d\omega = \int_{-\infty}^{\infty} F(\omega)G(\omega)e^{i\omega x}d\omega \\ &= \int_{-\infty}^{\infty} F(\omega)\left[\frac{1}{2\pi}\int_{-\infty}^{\infty} g(\xi)e^{-i\omega\xi}d\xi\right]e^{i\omega x}d\omega \end{aligned}$$

$$\begin{aligned}
&= \frac{1}{2\pi} \int_{-\infty}^{\infty} g(\xi) \underbrace{\left[ \int_{-\infty}^{\infty} F(\omega) e^{i\omega(x-\xi)} d\omega \right]}_{=f(x-\xi)} d\xi \\
&= \frac{1}{2\pi} \int_{-\infty}^{\infty} g(\xi) f(x-\xi) d\xi.
\end{aligned}$$

We denote the answer by  $f * g$ , meaning the convolution of  $f(x)$  and  $g(x)$ .

To use this for the heat equation, combining (9.4.6) and (9.4.9) we get

$$U(\omega, t) = F(\omega) e^{-k\omega^2 t}. \quad (9.4.10)$$

Therefore, by the convolution theorem and the inverse transform of a Gaussian, we get

$$u(x, t) = \frac{1}{2\pi} \int_{-\infty}^{\infty} f(\xi) \sqrt{\frac{\pi}{kt}} e^{-\frac{(x-\xi)^2}{4kt}} d\xi, \quad (9.4.11)$$

exactly as before.

### Example

Solve the one dimensional wave equation

$$u_{tt} - c^2 u_{xx} = 0, \quad -\infty < x < \infty, \quad (9.4.12)$$

subject to the initial conditions:

$$u(x, 0) = f(x), \quad (9.4.13)$$

$$u_t(x, 0) = 0. \quad (9.4.14)$$

The Fourier transform of the equation and the initial conditions yield

$$U_{tt}(\omega, t) + c^2 \omega^2 U(\omega, t) = 0, \quad (9.4.15)$$

$$U(\omega, 0) = F(\omega), \quad (9.4.16)$$

$$U_t(\omega, 0) = 0. \quad (9.4.17)$$

The solution is (treating (9.4.15) as ODE in  $t$  with  $\omega$  fixed)

$$U(\omega, t) = A(\omega) \cos c\omega t + B(\omega) \sin c\omega t. \quad (9.4.18)$$

The initial conditions combined with (9.4.18) give

$$U(\omega, t) = F(\omega) \cos c\omega t. \quad (9.4.19)$$

If we write  $\cos c\omega t$  in terms of complex exponentials, and find the inverse transform, we have

$$\begin{aligned}
u(x, t) &= \frac{1}{2} \int_{-\infty}^{\infty} F(\omega) \left[ e^{i\omega(x-ct)} + e^{i\omega(x+ct)} \right] d\omega \\
&= \frac{1}{2} [f(x-ct) + f(x+ct)].
\end{aligned} \quad (9.4.20)$$

Example

Solve Laplace's equation in a half plane

$$u_{xx} + u_{yy} = 0, \quad -\infty < x < \infty, \quad 0 < y < \infty, \quad (9.4.21)$$

subject to the boundary condition

$$u(x, 0) = f(x). \quad (9.4.22)$$

Fourier transform in  $x$  of the equation and the boundary condition yields

$$U_{yy}(\omega, y) - \omega^2 U(\omega, y) = 0, \quad (9.4.23)$$

$$U(\omega, 0) = F(\omega). \quad (9.4.24)$$

The solution is

$$U(\omega, y) = A(\omega)e^{\omega y} + B(\omega)e^{-\omega y}. \quad (9.4.25)$$

To ensure boundedness of the solution, we must have

$$\begin{aligned} A(\omega) &= 0 & \text{for } \omega > 0, \\ B(\omega) &= 0 & \text{for } \omega < 0. \end{aligned}$$

Therefore the solution should be

$$U(\omega, y) = C(\omega)e^{-|\omega|y}, \quad (9.4.26)$$

where, by the boundary condition,

$$C(\omega) = F(\omega).$$

We will show next that

$$g(x, y) = \int_{-\infty}^{\infty} e^{-|\omega|y} e^{i\omega x} d\omega = \frac{2y}{x^2 + y^2}. \quad (9.4.27)$$

$$\begin{aligned} g(x, y) &= \int_{-\infty}^0 e^{\omega y} e^{i\omega x} d\omega + \int_0^{\infty} e^{-\omega y} e^{i\omega x} d\omega \\ &= \frac{1}{y + ix} e^{\omega(y+ix)} \Big|_{-\infty}^0 + \frac{1}{-y + ix} e^{-\omega(y-ix)} \Big|_0^{\infty} \\ &= \frac{1}{y + ix} + \frac{1}{y - ix} = \frac{y - ix + y + ix}{y^2 + x^2} = \frac{2y}{x^2 + y^2} \end{aligned}$$

Thus we have

$$u(x, y) = \frac{1}{2\pi} \int_{-\infty}^{\infty} f(\xi) \frac{2y}{(x - \xi)^2 + y^2} d\xi. \quad (9.4.28)$$

## Problems

1. Solve the diffusion-convection equation

$$\begin{aligned}u_t &= ku_{xx} + cu_x, & -\infty < x < \infty, \\u(x, 0) &= f(x).\end{aligned}$$

2. Solve the linearized Korteweg-de Vries equation

$$\begin{aligned}u_t &= ku_{xxx}, & -\infty < x < \infty, \\u(x, 0) &= f(x).\end{aligned}$$

3. Solve Laplace's equation

$$u_{xx} + u_{yy} = 0, \quad 0 < x < L, \quad -\infty < y < \infty,$$

subject to

$$\begin{aligned}u(0, y) &= g_1(y), \\u(L, y) &= g_2(y).\end{aligned}$$

4. Solve the wave equation

$$\begin{aligned}u_{tt} &= u_{xx}, & -\infty < x < \infty, \\u(x, 0) &= 0, \\u_t(x, 0) &= g(x).\end{aligned}$$

5. Solve Laplace's equation

$$\begin{aligned}u_{xx} + u_{yy} &= 0, & -\infty < x < \infty, y > 0 \\u_y(x, 0) &= g(x).\end{aligned}$$



## 9.5 Fourier Sine and Cosine Transforms

If  $f(x)$  is an odd function, then the Fourier sine transform is defined by:

$$S(f(x)) = F^s(\omega) = \frac{2}{\pi} \int_0^{\infty} f(x) \sin \omega x \, dx \quad (9.5.1)$$

and the inverse transform is

$$f(x) = \int_0^{\infty} F^s(\omega) \sin \omega x \, d\omega. \quad (9.5.2)$$

If  $f(x)$  is an even function, then the Fourier cosine transform is given by:

$$C(f(x)) = F^c(\omega) = \frac{2}{\pi} \int_0^{\infty} f(x) \cos \omega x \, dx \quad (9.5.3)$$

$$f(x) = \int_0^{\infty} F^c(\omega) \cos \omega x \, d\omega \quad (9.5.4)$$

The superscripts  $c$  and  $s$  will be suppressed unless it is not clear. We can show

$$C \left[ \frac{\partial f}{\partial x} \right] = -\frac{2}{\pi} f(0) + \omega S[f] \quad (9.5.5)$$

$$S \left[ \frac{\partial f}{\partial x} \right] = -\omega C[f] \quad (9.5.6)$$

$$C \left[ \frac{\partial^2 f}{\partial x^2} \right] = -\frac{2}{\pi} \frac{df(0)}{dx} - \omega^2 C[f] \quad (9.5.7)$$

$$S \left[ \frac{\partial^2 f}{\partial x^2} \right] = \frac{2}{\pi} \omega f(0) - \omega^2 S[f] \quad (9.5.8)$$

Thus to use the cosine transform to solve second order PDEs we must have  $\frac{df}{dx}(0)$ . For sine transform we require  $f(0)$ .

Before we give any example, we would like to extend the convolution theorem (see section 9.4) to the Fourier sine and cosine transforms.

*Convolution theorem for Fourier sine transform* Let  $F(\omega)$  be the Fourier sine transform of  $f$  and  $G(\omega)$  be the Fourier cosine transform of  $g$ , i.e.

$$F(\omega) = S[f], \quad G(\omega) = C[g]$$

then the inverse Fourier sine transform of  $H(\omega) = F(\omega)G(\omega)$  is given by

$$h(x) = \frac{1}{\pi} \int_0^{\infty} f(\xi) [g(x - \xi) - g(x + \xi)] \, d\xi, \quad (9.5.9)$$

or

$$h(x) = \frac{1}{\pi} \int_0^{\infty} g(\xi) [f(\xi + x) - f(\xi - x)] \, d\xi. \quad (9.5.10)$$

The proof is similar to the convolution theorem in the previous section. We need to use the trigonometric identity

$$\sin x \sin y = \frac{1}{2} \cos(x - y) - \frac{1}{2} \cos(x + y).$$

*Convolution theorem for Fourier cosine transform* Let  $F(\omega)$  and  $G(\omega)$  be the Fourier cosine transforms of  $f$  and  $g$ , respectively, then the inverse Fourier cosine transform of  $H(\omega) = F(\omega)G(\omega)$  is given by

$$h(x) = \frac{1}{\pi} \int_0^\infty g(\xi) [f(x - \xi) + f(x + \xi)] d\xi. \quad (9.5.11)$$

The proof is similar to the convolution theorem for the sine transform. We need to use the trigonometric identity

$$\cos x \cos y = \frac{1}{2} \cos(x + y) + \frac{1}{2} \cos(x - y).$$

### Example

Solve Laplace's equation in a quarter plane

$$u_{xx} + u_{yy} = 0, \quad 0 < x, y < \infty, \quad (9.5.12)$$

$$u(0, y) = g(y), \quad (9.5.13)$$

$$u_y(x, 0) = f(x), \quad (9.5.14)$$

First we rewrite this as two problems. Let  $v(x, y)$  and  $w(x, y)$  satisfy Laplace's equation subject to

$$v(0, y) = g(y), \quad (9.5.15)$$

$$v_y(x, 0) = 0, \quad (9.5.16)$$

and

$$w(0, y) = 0, \quad (9.5.17)$$

$$w_y(x, 0) = f(x). \quad (9.5.18)$$

It is too easy to see that  $u(x, y) = v(x, y) + w(x, y)$  satisfies the original problem. Now we solve for  $v$  using Fourier cosine transform

$$V_{xx} - \omega^2 V = 0 \quad (9.5.19)$$

$$V(0, \omega) = G(\omega) \quad (9.5.20)$$

Therefore the solution is

$$V(x, \omega) = G(\omega)e^{-\omega x} \quad (9.5.21)$$

Now use the convolution transform and recalling that the inverse Fourier **cosine** transform of  $e^{-\omega x}$  is  $\frac{x}{x^2 + y^2}$ , we find

$$v(x, y) = \frac{1}{\pi} \int_0^\infty g(\xi) \left\{ \frac{x}{x^2 + (y - \xi)^2} + \frac{x}{x^2 + (y + \xi)^2} \right\} d\xi. \quad (9.5.22)$$

The problem for  $w$  requires the use of the Fourier sine transform, thus

$$W_{yy} - \omega^2 W = 0 \quad (9.5.23)$$

$$W_y(\omega, 0) = F(\omega) \quad (9.5.24)$$

Therefore

$$W(\omega, y) = F(\omega)e^{-\omega y} \quad (9.5.25)$$

Again using the convolution theorem and recalling the inverse Fourier **cosine** transform of  $e^{-\omega y}$  is  $\frac{y}{x^2 + y^2}$ , we have

$$w(x, y) = \frac{1}{\pi} \int_0^\infty f(\xi) \left\{ \frac{y}{y^2 + (x - \xi)^2} - \frac{y}{y^2 + (x + \xi)^2} \right\} d\xi. \quad (9.5.26)$$

Example Solve Laplace's equation in a semi-infinite strip

$$u_{xx} + u_{yy} = 0, \quad 0 < x < L, \quad 0 < y < \infty \quad (9.5.27)$$

$$u(0, y) = g_1(y), \quad (9.5.28)$$

$$u(L, y) = g_2(y), \quad (9.5.29)$$

$$u(x, 0) = f(x). \quad (9.5.30)$$

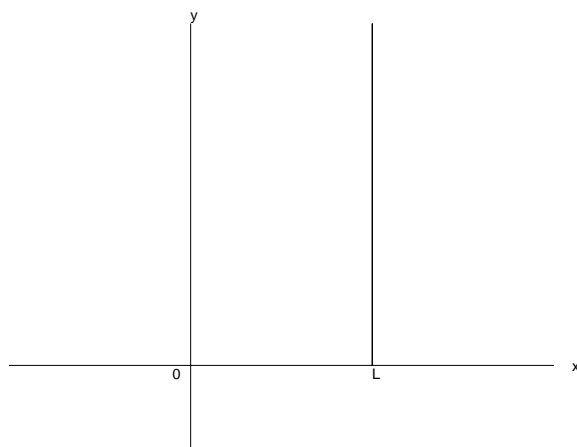

Figure 59: Domain for Laplace's equation example

Since  $u(x, 0)$  is given, we must use Fourier sine transform. The transformed equation is

$$U_{xx} - \omega^2 U + \frac{2}{\pi} \omega u(x, 0) = 0 \quad (9.5.31)$$

or

$$U_{xx} - \omega^2 U = -\frac{2}{\pi} \omega f(x) \quad (9.5.32)$$

subject to the boundary conditions

$$U(0, \omega) = G_1(\omega), \quad (9.5.33)$$

$$U(L, \omega) = G_2(\omega). \quad (9.5.34)$$

Another way is to solve the following two problems and avoid the inhomogeneity in (9.5.32)

1.

$$u_{xx}^1 + u_{yy}^1 = 0,$$

$$u^1(0, y) = g_1(y),$$

$$u^1(L, y) = g_2(y),$$

$$u^1(x, 0) = 0,$$

2.

$$u_{xx}^2 + u_{yy}^2 = 0,$$

$$u^2(0, y) = u^2(L, y) = 0,$$

$$u^2(x, 0) = f(x).$$

The solution of our problem will be the sum of the solutions of these two (principle of superposition!).

For the solution of problem 1, we take Fourier sine transform in  $y$  to get

$$U_{xx}^1(x, \omega) - \omega^2 U^1(x, \omega) = 0. \quad (9.5.35)$$

The solution is

$$U^1(x, \omega) = A(\omega) \sinh \omega x + B(\omega) \sinh \omega(L - x). \quad (9.5.36)$$

The boundary conditions lead to

$$\begin{aligned} B(\omega) \sinh \omega L &= \frac{2}{\pi} \int_0^\infty g_1(y) \sin \omega y \, dy, \\ A(\omega) \sinh \omega L &= \frac{2}{\pi} \int_0^\infty g_2(y) \sin \omega y \, dy. \end{aligned}$$

$A(\omega)$ ,  $B(\omega)$  are given in terms of the Fourier sine transform of  $g_2(y)$ ,  $g_1(y)$  respectively. The inverse transform is beyond the scope of this course and will require knowledge of complex variables. The solution of problem 2 does **NOT** require Fourier transform (why?).

$$u^2(x, y) = \sum_{n=1}^{\infty} a_n \sin \frac{n\pi}{L} x e^{-\frac{n\pi}{L} y} \quad (9.5.37)$$

## Problems

1. Derive the Fourier cosine transform of  $e^{-\alpha x^2}$ .
2. Determine the inverse cosine transform of  $\omega e^{-\omega\alpha}$  (Hint: use differentiation with respect to a parameter)
3. Solve by Fourier sine transform:

$$\begin{aligned}u_t &= k u_{xx}, & x > 0, & \quad t > 0 \\u(0, t) &= 1, \\u(x, 0) &= f(x).\end{aligned}$$

4. Solve the heat equation

$$\begin{aligned}u_t &= k u_{xx}, & x > 0, & \quad t > 0 \\u_x(0, t) &= 0, \\u(x, 0) &= f(x).\end{aligned}$$

5. Prove the convolution theorem for the Fourier sine transforms, i.e. (9.5.9) and (9.5.10).
6. Prove the convolution theorem for the Fourier cosine transforms, i.e. (9.5.11).
7.
  - a. Derive the Fourier sine transform of  $f(x) = 1$ .
  - b. Derive the Fourier cosine transform of  $f(x) = \int_0^x \phi(t) dt$ .
  - c. Derive the Fourier sine transform of  $f(x) = \int_0^x \phi(t) dt$ .
8. Determine the inverse sine transform of  $\frac{1}{\omega} e^{-\omega\alpha}$  (Hint: use integration with respect to a parameter)

## 9.6 Fourier Transform in 2 Dimensions

We define Fourier transform in 2 dimensions by generalizing the 1D case:

$$F(\omega_1, \omega_2) = \frac{1}{(2\pi)^2} \int_{-\infty}^{\infty} \int_{-\infty}^{\infty} f(x, y) e^{-i\omega_1 x} e^{-i\omega_2 y} dx dy, \quad (9.6.1)$$

$$f(x, y) = \int_{-\infty}^{\infty} \int_{-\infty}^{\infty} F(\omega_1, \omega_2) e^{i\omega_1 x} e^{i\omega_2 y} d\omega_1 d\omega_2. \quad (9.6.2)$$

If we let

$$\vec{\omega} = (\omega_1, \omega_2), \quad (9.6.3)$$

$$\vec{r} = (x, y), \quad (9.6.4)$$

then

$$F(\vec{\omega}) = \frac{1}{(2\pi)^2} \int_{-\infty}^{\infty} \int_{-\infty}^{\infty} f(\vec{r}) e^{-i\vec{\omega} \cdot \vec{r}} d\vec{r}, \quad (9.6.5)$$

$$f(\vec{r}) = \int_{-\infty}^{\infty} \int_{-\infty}^{\infty} F(\vec{\omega}) e^{i\vec{\omega} \cdot \vec{r}} d\vec{\omega}. \quad (9.6.6)$$

It is easy to show by definition that

$$\begin{aligned} \mathcal{F}(u_t) &= \frac{\partial}{\partial t} \mathcal{F}(u), \\ \mathcal{F}(u_x) &= i\omega_1 \mathcal{F}(u), \\ \mathcal{F}(u_y) &= i\omega_2 \mathcal{F}(u), \\ \mathcal{F}(\nabla u) &= i\vec{\omega} \mathcal{F}(u), \\ \mathcal{F}(\nabla^2 u) &= -\vec{\omega}^2 \mathcal{F}(u). \end{aligned}$$

Example Solve the heat equation

$$\begin{aligned} u_t &= k \nabla^2 u, & -\infty < x < \infty, & & -\infty < y < \infty, \\ u(x, y, 0) &= f(x, y). \end{aligned}$$

Using double Fourier transform we have

$$\begin{aligned} \frac{\partial}{\partial t} U &= -k \vec{\omega}^2 U \\ U(\vec{\omega}, 0) &= F(\vec{\omega}). \end{aligned}$$

The solution is

$$U(\vec{\omega}, t) = F(\vec{\omega}) e^{-k \vec{\omega}^2 t} \quad (9.6.7)$$

or when taking the inverse transform

$$u(x, y, t) = \int_{-\infty}^{\infty} \int_{-\infty}^{\infty} F(\vec{\omega}) e^{-k \vec{\omega}^2 t} e^{i\vec{\omega} \cdot \vec{r}} d\vec{\omega}. \quad (9.6.8)$$

Using a generalization of the convolution theorem, i. e. if  $H(\vec{\omega}) = F(\vec{\omega})G(\vec{\omega})$  then

$$h(x, y, t) = \frac{1}{(2\pi)^2} \int_{-\infty}^{\infty} \int_{-\infty}^{\infty} f(\vec{r}_0)g(\vec{r} - \vec{r}_0)d\vec{r}_0, \quad (9.6.9)$$

we have

$$u(x, y, t) = \int_{-\infty}^{\infty} \int_{-\infty}^{\infty} f(\vec{r}_0) \frac{1}{4\pi kt} e^{-\frac{(\vec{r} - \vec{r}_0)^2}{4kt}} d\vec{r}_0. \quad (9.6.10)$$

We see that the influence function is the product of the influence functions for two one dimensional heat equations.



## Problems

1. Solve the wave equation

$$\begin{aligned}u_{tt} &= c^2 \nabla^2 u, & -\infty < x < \infty, & & -\infty < y < \infty, \\u(x, y, 0) &= f(x, y), \\u_t(x, y, 0) &= 0.\end{aligned}$$

## SUMMARY

Definition of Fourier Transform and its Inverse:

$$F(\omega) = \frac{1}{2\pi} \int_{-\infty}^{\infty} f(x)e^{-i\omega x} dx$$

$$f(x) = \int_{-\infty}^{\infty} F(\omega)e^{i\omega x} d\omega.$$

Table of Fourier Transforms

$f(x)$	$F(\omega)$	
$e^{-\alpha x^2}$	$\frac{1}{\sqrt{4\pi\alpha}} e^{-\frac{\omega^2}{4\alpha}}$	Gaussian
$\frac{\partial f}{\partial t}$	$\frac{\partial F}{\partial t}$	derivatives
$\frac{\partial f}{\partial x}$	$i\omega F(\omega)$	
$\frac{\partial^2 f}{\partial x^2}$	$-\omega^2 F(\omega)$	
$\frac{1}{2\pi} \int_{-\infty}^{\infty} f(\xi)g(x - \xi)d\xi$	$F(\omega)G(\omega)$	convolution
$\delta(x - x_0)$	$\frac{1}{2\pi} e^{-i\omega x_0}$	Dirac
$f(x - \beta)$	$e^{-i\omega\beta} F(\omega)$	shift
$xf(x)$	$i \frac{dF}{d\omega}$	multiplication by $x$
$\frac{2\alpha}{x^2 + \alpha^2}$	$e^{- \omega \alpha}$	
$\int_{-\infty}^x \phi(t)dt$	$+\frac{1}{i\omega} \mathcal{F}(\phi(x))$	assuming $\int_{-\infty}^{\infty} \phi(t)dt = 0$
$f(x) = \begin{cases} 0 &  x  > a \\ 1 &  x  < a \end{cases}$	$\frac{1}{\pi} \frac{\sin a\omega}{\omega}$	

Definition of Fourier Sine Transform and its Inverse:

$$S(f(x)) = F^s(\omega) = \frac{2}{\pi} \int_0^\infty f(x) \sin \omega x \, dx$$

$$f(x) = \int_0^\infty F^s(\omega) \sin \omega x \, d\omega .$$

Table of Fourier Sine Transforms

$f(x)$	$S[f]$
$\frac{df}{dx}$	$-\omega C[f]$
$\frac{d^2 f}{dx^2}$	$\frac{2}{\pi} \omega f(0) - \omega^2 S[f]$
$\frac{x}{x^2 + \beta^2}$	$e^{-\omega\beta}$
$e^{-\alpha x}$	$\frac{2}{\pi} \frac{\omega}{\alpha^2 + \omega^2}$
$\int_0^x \phi(t) dt$	$\frac{1}{\omega} C(\phi(x))$
1	$\frac{2}{\pi} \frac{1}{\omega}$
$\frac{1}{\pi} \int_0^\infty f(\xi)[g(x - \xi) - g(x + \xi)] d\xi$	$S[f]C[g]$

Definition of Fourier Cosine Transform and its Inverse:

$$C(f(x)) = F^c(\omega) = \frac{2}{\pi} \int_0^\infty f(x) \cos \omega x \, dx$$

$$f(x) = \int_0^\infty F^c(\omega) \cos \omega x \, d\omega$$

Table of Fourier Cosine Transforms

$f(x)$	$C[f]$
$\frac{df}{dx}$	$-\frac{2}{\pi} f(0) + \omega S[f]$
$\frac{d^2 f}{dx^2}$	$-\frac{2}{\pi} \frac{df}{dx}(0) - \omega^2 C[f]$
$\frac{\beta}{x^2 + \beta^2}$	$e^{-\omega\beta}$
$e^{-\alpha x}$	$\frac{2}{\pi} \frac{\alpha}{\alpha^2 + \omega^2}$
$e^{-\alpha x^2}$	$\frac{2}{\sqrt{4\pi\alpha}} e^{-\frac{\omega^2}{4\alpha}}$
$\int_0^x \phi(t) dt$	$-\frac{1}{\omega} S(\phi(x))$
$\frac{1}{\pi} \int_0^\infty g(\xi)[f(x - \xi) + f(x + \xi)] d\xi$	$C[f]C[g]$

Definition of Double Fourier Transform and its Inverse:

$$F(\omega_1, \omega_2) = \frac{1}{(2\pi)^2} \int_{-\infty}^{\infty} \int_{-\infty}^{\infty} f(x, y) e^{-i\omega_1 x} e^{-i\omega_2 y} dx dy$$

$$f(x, y) = \int_{-\infty}^{\infty} \int_{-\infty}^{\infty} F(\omega_1, \omega_2) e^{i\omega_1 x} e^{i\omega_2 y} d\omega_1 d\omega_2 .$$

Table of Double Fourier Transforms

$f(x, y)$	$F(\vec{\omega})$
$f_x$	$i\omega_1 F(\vec{\omega})$
$f_y$	$i\omega_2 F(\vec{\omega})$
$\nabla^2 f$	$-\vec{\omega}^2 F(\vec{\omega})$
$\frac{\pi}{\beta} e^{-r^2/4\beta}$	$e^{-\beta\vec{\omega}^2}$
$f(\vec{r} - \vec{\beta})$	$e^{-i\vec{\omega} \cdot \vec{\beta}} F(\vec{\omega})$
$\frac{1}{(2\pi)^2} \int \int f(\vec{r}_0) g(\vec{r} - \vec{r}_0) d\vec{r}_0$	$F(\vec{\omega}) G(\vec{\omega})$

## 10 Green's Functions

### 10.1 Introduction

In the previous chapters, we discussed a variety of techniques for the solution of PDEs, namely: the method of characteristics (for hyperbolic problems only, linear as well as non-linear), the method of separation of variables (for linear problem on certain domains) and Fourier transform (for infinite and semi-infinite domains). The method of separation of variables, when it works, it yields an infinite series which often converges slowly. Thus it is difficult to obtain an insight into the over-all behavior of the solution, its behavior near edges and so on. That's why, the method of characteristics is preferable over the method of separation of variables for hyperbolic problems. The Green's function approach would allow us to have an integral representation of the solution (as in the method of characteristics) instead of an infinite series.

Physically, the method is obvious. To obtain the field,  $u$ , caused by a distributed source, we calculate the effect of each elementary portion of source and add (integrate) them all. If  $G(\vec{r}; \vec{r}_0)$  is the field at the observer's point  $\vec{r}$  caused by a unit source at the source point  $\vec{r}_0$ , then the field at  $\vec{r}$  caused by a source distribution  $\rho(\vec{r}_0)$  is the integral of  $\rho(\vec{r}_0)G(\vec{r}; \vec{r}_0)$  over the whole range of  $\vec{r}_0$  occupied by the source. The function  $G$  is called Green's function. We can satisfy boundary conditions in the same way. What may be surprising is that essentially the same function gives the answer in both cases. Physically, this means that the boundary conditions can be thought of as being equivalent to sources. We have seen this in Chapter 8 when discussing the method of eigenfunction expansion to solve inhomogeneous problems. The inhomogeneous boundary conditions were replaced by homogeneous ones and the source has been changed appropriately.

### 10.2 One Dimensional Heat Equation

In this section, we demonstrate the idea of Green's function by analyzing the solution of the one dimensional heat equation,

$$u_t = u_{xx}, \quad 0 < x < 1, \quad t > 0, \quad (10.2.1)$$

subject to

$$u(x, 0) = f(x), \quad 0 < x < 1, \quad (10.2.2)$$

$$u(0, t) = u(1, t) = 0. \quad (10.2.3)$$

The method of separation of variables yields the solution

$$u(x, t) = \sum_{n=1}^{\infty} a_n \sin n\pi x \cdot e^{-(n\pi)^2 t}, \quad (10.2.4)$$

where  $a_n$  are the Fourier coefficients of the expansion of  $f(x)$  in Fourier sine series,

$$a_n = 2 \int_0^1 f(x) \sin n\pi x dx. \quad (10.2.5)$$

We substitute (10.2.5) into (10.2.4) to obtain after reversing the order of integration and summation

$$u(x, t) = \int_0^1 f(s) \left( \sum_{n=1}^{\infty} 2 \sin n\pi s \cdot \sin n\pi x \cdot e^{-(n\pi)^2 t} \right) ds. \quad (10.2.6)$$

The quantity in parenthesis is called influence function for the initial condition. It expresses the fact that the temperature at point  $x$  at time  $t$  is due to the initial temperature  $f$  at  $s$ . To obtain the temperature  $u(x, t)$ , we sum (integrate) the influence of all possible initial points,  $s$ .

What about the solution of the inhomogeneous problem,

$$u_t = u_{xx} + Q(x, t), \quad 0 < x < 1, \quad t > 0, \quad (10.2.7)$$

subject to the same initial and boundary conditions? As we have seen in Chapter 8, we expand  $u$  and  $Q$  in the eigenfunctions  $\sin n\pi x$ ,

$$Q(x, t) = \sum_{n=1}^{\infty} q_n(t) \sin n\pi x, \quad (10.2.8)$$

with

$$q_n(t) = 2 \int_0^1 Q(x, t) \sin n\pi x dx, \quad (10.2.9)$$

and

$$u(x, t) = \sum_{n=1}^{\infty} u_n(t) \sin n\pi x. \quad (10.2.10)$$

Thus we get the inhomogeneous ODE

$$\dot{u}_n(t) + (n\pi)^2 u_n(t) = q_n(t), \quad (10.2.11)$$

whose solution is

$$u_n(t) = u_n(0) e^{-(n\pi)^2 t} + \int_0^t q_n(\tau) e^{-(n\pi)^2 (t-\tau)} d\tau, \quad (10.2.12)$$

where

$$u_n(0) = a_n = 2 \int_0^1 f(x) \sin n\pi x dx. \quad (10.2.13)$$

Again, we substitute (10.2.13), (10.2.9) and (10.2.12) in (10.2.10) we have

$$\begin{aligned} u(x, t) = & \int_0^1 f(s) \left( \sum_{n=1}^{\infty} 2 \sin n\pi s \cdot \sin n\pi x \cdot e^{-(n\pi)^2 t} \right) ds \\ & + \int_0^1 \int_0^t Q(s, \tau) \left( \sum_{n=1}^{\infty} 2 \sin n\pi s \cdot \sin n\pi x \cdot e^{-(n\pi)^2 (t-\tau)} \right) d\tau ds. \end{aligned} \quad (10.2.14)$$

We therefore introduce Green's function

$$G(x; s, t - \tau) = 2 \sum_{n=1}^{\infty} \sin n\pi s \cdot \sin n\pi x \cdot e^{-(n\pi)^2 (t-\tau)}, \quad (10.2.15)$$

and the solution is then

$$u(x, t) = \int_0^1 f(s)G(x; s, t)ds + \int_0^1 \int_0^t Q(s, \tau)G(x; s, t - \tau)d\tau ds. \quad (10.2.16)$$

As we said in the introduction, the same Green's function appears in both. Note that the Green's function depends only on the elapsed time  $t - \tau$ .

## Problems

1. Consider the heat equation in one dimension

$$\frac{\partial u}{\partial t} = \frac{\partial^2 u}{\partial x^2} + Q(x, t), \quad 0 < x < 1, \quad t > 0,$$

$$u(x, 0) = f(x),$$

$$u(0, t) = A(t),$$

$$u(1, t) = B(t).$$

Obtain a solution in the form (10.2.16).

2. Consider the same problem subject to the homogeneous boundary conditions

$$u_x(0, t) = u_x(1, t) = 0$$

- a. Obtain a solution by any method.
  - b. Obtain a solution in the form (10.2.16).
3. Solve the wave equation in one dimension

$$\frac{\partial^2 u}{\partial t^2} = \frac{\partial^2 u}{\partial x^2} + Q(x, t), \quad 0 < x < 1, \quad t > 0,$$

$$u(x, 0) = f(x),$$

$$u_t(x, 0) = g(x),$$

$$u(0, t) = 0,$$

$$u(1, t) = 0.$$

Define functions such that a solution in a similar form to (10.2.16) exists.

4. Solve the above wave equation subject to

a.

$$u_x(0, t) = u_x(1, t) = 0.$$

b.

$$u_x(0, t) = 0, \quad u_x(1, t) = B(t).$$

c.

$$u(0, t) = A(t), \quad u_x(1, t) = 0.$$



### 10.3 Green's Function for Sturm-Liouville Problems

Consider the Sturm-Liouville boundary value problem

$$-(p(x)y'(x))' + q(x)y(x) = f(x), \quad 0 < x < 1 \quad (10.3.1)$$

$$y(0) - h_0y'(0) = 0, \quad (10.3.2)$$

$$y(1) - h_1y'(1) = 0, \quad (10.3.3)$$

where  $p(x) \neq 0$ ,  $p'(x)$ ,  $q(x)$  and  $f(x)$  are continuous on  $[0, 1]$  and  $h_0, h_1$  are real constants. We would like to obtain Green's function  $G(x; s)$  so that the solution is

$$y(x) = \int_0^1 G(x; s)f(s)ds. \quad (10.3.4)$$

The function  $G(x; s)$  is called Green's function for (10.3.1)-(10.3.3) if it is continuous on  $0 \leq x, s \leq 1$  and (10.3.4) uniquely solves (10.3.1)-(10.3.3) for every continuous function  $f(x)$ .

To see why (10.3.4) is reasonable, we consider the steady state temperature in a rod. In this case  $f(x)$  represents a heat source intensity along the rod. Consider, a heat distribution  $f_s(x)$  of unit intensity localized at point  $x = s$  in the rod: That is, assume that

$$f_s(x) = 0, \quad \text{for } |x - s| > \epsilon, \quad \epsilon > 0, \quad \epsilon \text{ is small}$$

and

$$\int_{s-\epsilon}^{s+\epsilon} f_s(x)dx = 1. \quad (10.3.5)$$

Let  $y(x) = G_\epsilon(x; s)$  be the steady state temperature induced by the source  $f_s(x)$ . As  $\epsilon \rightarrow 0$ , it is hoped that the temperature distribution  $G_\epsilon(x; s)$  will converge to a limit  $G(x; s)$  corresponding to a heat source of unit intensity applied at  $x = s$ . Now, imagine that the rod is made of a large number ( $N$ ) of tiny pieces, each of length  $2\epsilon$ , and let  $s_k$  be a point in the  $k^{\text{th}}$  piece. The heat source  $f(x)$  delivers an amount of heat  $2\epsilon f(s_k)$  to the  $k^{\text{th}}$  piece. Since the problem is linear and homogeneous, the temperature at  $x$  caused by the heating near  $s_k$  is nearly  $G_\epsilon(x; s_k)f(s_k)2\epsilon$ , thus

$$y(x) \simeq \sum_{k=1}^N 2\epsilon G_\epsilon(x; s_k)f(s_k), \quad (10.3.6)$$

is the total contribution from all pieces. As we let  $\epsilon \rightarrow 0$  and the number of pieces approach infinity

$$y(x) = \lim_{\epsilon \rightarrow 0} \sum_{k=1}^N 2\epsilon G_\epsilon(x; s_k)f(s_k) = \int_0^1 G(x; s)f(s)ds. \quad (10.3.7)$$

This discussion suggests the following properties of Green's function  $G(x; s)$ .

1. The solution  $G_\epsilon(x; s)$  with  $f = f_s(x)$  satisfies

$$\mathcal{L}G_\epsilon = f_s(x) = 0, \quad \text{for } |x - s| > \epsilon \quad (10.3.8)$$

where the operator  $\mathcal{L}$  as defined in Chapter 6,

$$\mathcal{L}y = -(py')' + qy. \quad (10.3.9)$$

We can write this also as

$$-\frac{d}{dx} \left( p(x) \frac{d}{dx} G(x; s) \right) + q(x)G(x; s) = 0, \quad \text{for } x \neq s. \quad (10.3.10)$$

This is related to Dirac delta function to be discussed in the next section.

2.  $G(x; s)$  satisfies the boundary conditions (10.3.2)-(10.3.3) since each  $G_\epsilon(x; s)$  does.
3. The function  $G_\epsilon(x; s)$  has a continuous second derivative, since it is a solution to (10.3.1). The question is how smooth the limit  $G(x; s)$  is? It can be shown that the first derivative has a jump discontinuity, i.e.

$$\frac{\partial G(s^+; s)}{\partial x} - \frac{\partial G(s^-; s)}{\partial x} = -\frac{1}{p(s)}, \quad \text{Jump Condition} \quad (10.3.11)$$

where

$$s^\pm = \lim_{\epsilon \rightarrow 0} (s \pm \epsilon). \quad (10.3.12)$$

We now turn to the proof of (10.3.4) under simpler boundary conditions ( $h_0 = h_1 = 0$ ), i.e.

$$y(0) = y(1) = 0. \quad (10.3.13)$$

The proof is constructive and called Lagrange's method. It is based on Lagrange's identity (6.3.3).

Suppose we can find a function  $w \neq 0$  so that

$$\mathcal{L}w = 0. \quad (10.3.14)$$

Apply Lagrange's identity (6.3.3) with  $u = w$  and  $v = y$ , to get

$$w\mathcal{L}y - y\mathcal{L}w = -\frac{d}{dx} [p(wy' - w'y)].$$

On the other hand,

$$w\mathcal{L}y - y\mathcal{L}w = wf,$$

since  $\mathcal{L}w = 0$  and  $\mathcal{L}y = f$ . Therefore we can integrate the resulting equation

$$-\frac{d}{dx} [p(wy' - yw')] = wf, \quad (10.3.15)$$

and have a first order ODE for  $y$ . Thus  $w$  is called an integrating factor for  $\mathcal{L}y = f$ .

Suppose we can find integrating factors  $u$  and  $v$  such that

$$\mathcal{L}u = 0, \quad u(0) = 0, \quad (10.3.16)$$

and

$$\mathcal{L}v = 0, \quad v(1) = 0, \quad (10.3.17)$$

i.e. each one satisfies only one of the boundary conditions. Choose  $w$  to be either  $u$  or  $v$  from (10.3.16)-(10.3.17), thus by integration of (10.3.15) we have

$$\int_0^x u(s)f(s)ds = -p(x)(uy' - u'y), \quad (10.3.18)$$

$$\int_x^1 v(s)f(s)ds = +p(x)(vy' - v'y). \quad (10.3.19)$$

Note that the limits of integration are chosen differently in each case. Now we can eliminate  $y'$  and get

$$v(x) \int_0^x u(s)f(s)ds + u(x) \int_x^1 v(s)f(s)ds = -p(x)W(x)y(x), \quad (10.3.20)$$

where the Wronskian  $W(x)$  is

$$W(x) = \begin{vmatrix} u(x) & v(x) \\ u'(x) & v'(x) \end{vmatrix}. \quad (10.3.21)$$

It is easy to see that (exercise)

$$p(x)W(x) = c. \quad (10.3.22)$$

Therefore

$$y(x) = -\frac{1}{c} \int_0^x u(s)v(x)f(s)ds - \frac{1}{c} \int_x^1 u(x)v(s)f(s)ds$$

or

$$y(x) = \int_0^1 G(x; s)f(s)ds \quad (10.3.23)$$

where (if we choose  $c = -1$ )

$$G(x; s) = \begin{cases} u(s)v(x) & 0 \leq s \leq x \leq 1 \\ u(x)v(s) & 0 \leq x \leq s \leq 1. \end{cases} \quad (10.3.24)$$

This completes the proof of (10.3.4) and we have a way to construct Green's function by solving (10.3.16)-(10.3.17).

Example Obtain Green's function for the steady state temperature in a homogeneous rod of length  $L$  and with insulated lateral surface. Assume that the left end of the bar is at zero temperature, the right end is insulated, and the source of heat is  $f(x)$ . The problem can be formulated mathematically as

$$-ku_{xx} = f(x), \quad 0 < x < L, \quad (10.3.25)$$

$$u(0) = 0, \quad (10.3.26)$$

$$u'(L) = 0. \quad (10.3.27)$$

To find Green's function, we solve

$$-ku'' = 0, \quad u(0) = 0, \quad (10.3.28)$$

$$-kv'' = 0, \quad v'(L) = 0, \quad (10.3.29)$$

and choose  $c = -1$ , i.e.

$$kW = -1. \quad (10.3.30)$$

The solution of each ODE satisfying its end condition is

$$u = ax, \quad (10.3.31)$$

$$v = b. \quad (10.3.32)$$

The constants  $a, b$  must be chosen so as to satisfy the Wronskian condition (10.3.30), i.e.

$$a = \frac{1}{k}$$

$$b = 1$$

and therefore (10.3.24) becomes

$$G(x; s) = \begin{cases} \frac{s}{k} & 0 \leq s \leq x \leq L \\ \frac{x}{k} & 0 \leq x \leq s \leq L. \end{cases} \quad (10.3.33)$$

Notice that Green's function is symmetric as in previous cases; physically this means that the temperature at  $x$  due to a unit source at  $s$  equals the temperature at  $s$  due to a unit source at  $x$ . This is called Maxwell's reciprocity.

Now consider the Sturm-Liouville problem

$$\mathcal{L}y - \lambda ry = f(x), \quad 0 < x < 1, \quad (10.3.34)$$

subject to (10.3.2)-(10.3.3).

If  $\lambda = 0$ , this problem reduces to (10.3.1), while if  $f \equiv 0$  we have the eigenvalue problem of Sturm-Liouville type (Chapter 6). Assume that (10.3.1) has a Green's function  $G(x; s)$ , then any solution of (10.3.34) satisfies (moving  $\lambda ry$  to the right)

$$y(x) = \int_0^1 G(x; s) [f(s) + \lambda r(s)y(s)] ds$$

or

$$y(x) = \lambda \int_0^1 G(x; s)r(s)y(s)ds + F(x), \quad (10.3.35)$$

where

$$F(x) = \int_0^1 G(x; s)f(s)ds. \quad (10.3.36)$$

Equation (10.3.35) is called a Fredholm integral equation of the second kind. The function  $G(x; s)r(s)$  is called its kernel. If  $f(x) \equiv 0$  then (10.3.35) becomes

$$y(x) = \lambda \int_0^1 G(x; s)r(s)y(s)ds. \quad (10.3.37)$$

For later reference, equations (10.3.35), (10.3.37) can be easily symmetrized if  $r(x) > 0$ . The symmetric equation is

$$z(x) = \lambda \int_0^1 k(x; s)z(s)ds + \hat{F}(x), \quad (10.3.38)$$

where

$$z(x) = \sqrt{r(x)}y(x),$$

$$k(x; s) = G(x; s)\sqrt{r(x)}\sqrt{r(s)},$$

and

$$\hat{F}(x) = \sqrt{r(x)}F(x).$$

## Problems

1. Show that Green's function is unique if it exists.

Hint: Show that if there are 2 Green's functions  $G(x; s)$  and  $H(x; s)$  then

$$\int_0^1 [G(x; s) - H(x; s)] f(s) ds = 0.$$

2. Find Green's function for each

a.

$$\begin{aligned} -ku_{xx} &= f(x), & 0 < x < L, \\ u'(0) &= 0, \\ u(L) &= 0. \end{aligned}$$

b.

$$\begin{aligned} -u_{xx} &= F(x), & 0 < x < L, \\ u'(0) &= 0, \\ u'(L) &= 0. \end{aligned}$$

c.

$$\begin{aligned} -u_{xx} &= f(x), & 0 < x < L, \\ u(0) - u'(0) &= 0, \\ u(L) &= 0. \end{aligned}$$

3. Find Green's function for

$$\begin{aligned} -ky'' + \ell y &= 0, & 0 < x < 1, \\ y(0) - y'(0) &= 0, \\ y(1) &= 0. \end{aligned}$$

4. Find Green's function for the initial value problem

$$\begin{aligned} \mathcal{L}y &= f(x), \\ y(0) &= y'(0) = 0. \end{aligned}$$

Show that the solution is

$$y(x) = \int_0^x G(x; s) f(s) ds.$$

5. Prove (10.3.22).

## 10.4 Dirac Delta Function

Define a pulse of unit length starting at  $x_i$  as

$$u(x_i) = \begin{cases} 1 & (x_i, x_i + \Delta x) \\ 0 & \text{otherwise} \end{cases}$$

then any function  $f(x)$  on the interval  $(a, b)$  can be represented approximately by

$$f(x) \cong \sum_{i=1}^N f(x_i)u(x_i), \quad (10.4.1)$$

see figure 60.

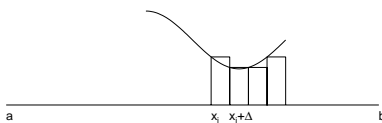

Figure 60: Representation of a continuous function by unit pulses

This is a piecewise constant approximation of  $f(x)$ . As  $\Delta x \rightarrow 0$  the number of points  $N$  approaches  $\infty$  and thus at the limit, the infinite series becomes the integral:

$$f(x) = \int_a^b f(x_i)\delta(x - x_i)dx, \quad (10.4.2)$$

where  $\delta(x - x_i)$  is the limit of a unit pulse concentrated at  $x_i$  divided by  $\Delta x$ , see figure 61.

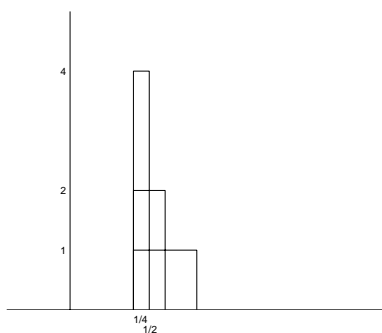

Figure 61: Several impulses of unit area

The Dirac delta function,  $\delta(x - x_i)$ , can also be defined as a limit of any sequence of concentrated pulses. It satisfies the following:

$$\int_{-\infty}^{\infty} \delta(x - x_i)dx = 1, \quad (10.4.3)$$

$$\delta(x - x_i) = \delta(x_i - x), \quad (10.4.4)$$

$$f(x) = \int_{-\infty}^{\infty} f(x_i)\delta(x - x_i)dx, \quad \text{for any } f, \quad (10.4.5)$$

$$\delta(x - x_i) = \frac{d}{dx}H(x - x_i), \quad (10.4.6)$$

where the Heaviside function

$$H(x - x_i) = \begin{cases} 0 & x < x_i \\ 1 & x > x_i, \end{cases} \quad (10.4.7)$$

$$H(x - x_i) = \int_{-\infty}^x \delta(\xi - x_i)d\xi, \quad (10.4.8)$$

$$\delta(c(x - x_i)) = \frac{1}{|c|}\delta(x - x_i). \quad (10.4.9)$$

The Dirac delta function is related to Green's function via

$$\mathcal{L}G(x; s) = \delta(x - s), \quad (10.4.10)$$

(since  $\delta(x - s) = 0$  for  $x \neq s$ , compare (10.4.10) with (10.3.8) ) that is Green's function is the response at  $x$  due to a concentrated source at  $s$ . To prove this, we find the solution  $u$  of:

$$\mathcal{L}u = \delta(x - s). \quad (10.4.11)$$

Using (10.3.4) with  $f(x) = \delta(x - s)$ , we have

$$u(x) = \int_0^1 G(x; \sigma)\delta(\sigma - s)d\sigma$$

which by (10.4.5) becomes,

$$u(x) = G(x; s). \quad (10.4.12)$$

Substituting (10.4.12) in (10.4.11) yields (10.4.10).



## Problems

1. Derive (10.4.3) from (10.4.2).
2. Show that (10.4.8) satisfies (10.4.7).
3. Derive (10.4.9)  
Hint: use a change of variables  $\xi = c(x - x_i)$ .

## 10.5 Nonhomogeneous Boundary Conditions

The problem to be considered in this section is

$$\mathcal{L}u = f(x), \quad 0 < x < 1, \quad (10.5.1)$$

subject to the nonhomogeneous boundary conditions

$$u(0) = A, \quad (10.5.2)$$

$$u(1) = B. \quad (10.5.3)$$

The Green's function  $G(x; s)$  satisfies

$$\mathcal{L}G = \delta(x - s), \quad (10.5.4)$$

$$G(0; s) = 0, \quad (10.5.5)$$

$$G(1; s) = 0, \quad (10.5.6)$$

since Green's function always satisfies homogeneous boundary conditions. Now we utilize Green's formula

$$\int_0^1 (u\mathcal{L}G - G\mathcal{L}u) dx = u \left. \frac{dG(x; s)}{dx} \right|_0^1 - G(x; s) \left. \frac{du}{dx} \right|_0^1.$$

The right hand side will have contribution from the first term only, since  $u$  doesn't vanish on the boundary. Thus

$$u(s) = \int_0^1 G(x; s) \underbrace{f(x)}_{\mathcal{L}u} dx + B \left. \frac{dG(x; s)}{dx} \right|_{x=1} - A \left. \frac{dG(x; s)}{dx} \right|_{x=0}.$$

## Problems

1. Consider

$$u_t = u_{xx} + Q(x, t), \quad 0 < x < 1, \quad t > 0,$$

subject to

$$\begin{aligned} u(0, t) = u_x(1, t) &= 0, \\ u(x, 0) &= f(x). \end{aligned}$$

- Solve by the method of eigenfunction expansion.
- Determine the Green's function.
- If  $Q(x, t) = Q(x)$ , independent of  $t$ , take the limit as  $t \rightarrow \infty$  of part (b) in order to determine the Green's function for the steady state.

2. Consider

$$\begin{aligned} u_{xx} + u &= f(x), \quad 0 < x < 1, \\ u(0) = u(1) &= 0. \end{aligned}$$

Determine the Green's function.

3. Give the solution of the following problems in terms of the Green's function

- $u_{xx} = f(x)$ , subject to  $u(0) = A$ ,  $u_x(1) = B$ .
- $u_{xx} + u = f(x)$ , subject to  $u(0) = A$ ,  $u(1) = B$ .
- $u_{xx} = f(x)$ , subject to  $u(0) = A$ ,  $u_x(1) + u(1) = 0$ .

4. Solve

$$\begin{aligned} \frac{dG}{dx} &= \delta(x - s), \\ G(0; s) &= 0. \end{aligned}$$

Show that  $G(x; s)$  is not symmetric.

5. Solve

$$\begin{aligned} u_{xxxx} &= f(x), \\ u(0) = u(1) = u_x(0) = u_{xx}(1) &= 0, \end{aligned}$$

by obtaining Green's function.

## 10.6 Fredholm Alternative And Modified Green's Functions

Theorem (Fredholm alternative)

For nonhomogeneous problems

$$\mathcal{L}y = f, \quad (10.6.1)$$

subject to homogeneous boundary conditions (10.3.2)-(10.3.3) either of the following holds

1.  $y = 0$  is the only solution to the homogeneous problem

$$\mathcal{L}y = 0, \quad (10.6.2)$$

that is,  $\lambda = 0$  is not an eigenvalue. In this case the nonhomogeneous problem has a unique solution.

2. There are nontrivial solutions to the homogeneous problem, say  $\phi_n(x)$  (i.e.  $\lambda = 0$  is an eigenvalue with eigenfunctions  $\phi_n(x)$ ), in which case the nonhomogeneous problem has no solution or an infinite number of solutions.

Remarks:

1. This theorem is well known from Linear Algebra concerning the solution of systems of linear algebraic equations.
2. In order to have infinite number of solutions, the forcing term  $f(x)$  must be orthogonal to all solutions of the homogeneous.
3. This result can be generalized to higher dimensions.

Example Consider

$$u_{xx} + Au = e^x, \quad (A \neq n^2 \text{ for any integer}) \quad (10.6.3)$$

$$u(0) = u(\pi) = 0. \quad (10.6.4)$$

The homogeneous equation

$$u_{xx} + Au = 0, \quad (A \neq n^2 \text{ for any integer}) \quad (10.6.5)$$

with the same boundary conditions has only the trivial solution. Therefore the nonhomogeneous problem has a unique solution. The theorem does not tell how to find that solution. We can use, for example, the method of eigenfunction expansion. Let

$$u(x) = \sum_{n=1}^{\infty} u_n \sin nx \quad (10.6.6)$$

then

$$u_n = \frac{\alpha_n}{A - n^2} \quad (10.6.7)$$

where  $\alpha_n$  are the Fourier coefficients of the expansion of  $e^x$  in the eigenfunctions  $\sin nx$ .

If we change the boundary conditions to

$$u_x(0) = u_x(\pi) = 0 \quad (10.6.8)$$

and take  $A = 0$  then the homogeneous equation ( $u_{xx} = 0$ ) has the solution

$$u = c. \quad (10.6.9)$$

Therefore the nonhomogeneous has no solution (since the forcing term  $e^x$  is not orthogonal to  $u = c$ ).

Now we discuss the solution of

$$\mathcal{L}u = f, \quad 0 < x < L, \quad (10.6.10)$$

subject to homogeneous boundary conditions if  $\lambda = 0$  is an eigenvalue.

If  $\lambda = 0$  is not an eigenvalue, we have shown earlier that we can find Green's function by solving

$$\mathcal{L}G = \delta(x - s). \quad (10.6.11)$$

Suppose then  $\lambda = 0$  is an eigenvalue, then there are nontrivial homogeneous solutions  $v_h$ , that is

$$\mathcal{L}v_h = 0, \quad (10.6.12)$$

and to have a solution for (10.6.10), we must have

$$\int_0^L f(x)v_h(x)dx = 0. \quad (10.6.13)$$

Since the right hand side of (10.6.11) is not orthogonal to  $v_h$ , in fact

$$\int_0^L v_h(x)\delta(x - s)dx = v_h(s) \neq 0 \quad (10.6.14)$$

we cannot expect to get a solution for (10.6.11), i.e. we cannot find  $G$ . To overcome the problem, we note that

$$\delta(x - s) + cv_h(x) \quad (10.6.15)$$

is orthogonal to  $v_h(x)$  if we choose  $c$  appropriately, that is

$$c = -\frac{v_h(s)}{\int_0^L v_h^2(x)dx}. \quad (10.6.16)$$

Thus, we introduce the modified Green's function

$$\hat{G}(x; s) = G(x; s) + \beta v_h(x)v_h(s) \quad (\text{any } \beta) \quad (10.6.17)$$

which satisfies

$$\mathcal{L}\hat{G} = \mathcal{L}G + \beta v_h(s) \underbrace{\mathcal{L}v_h(x)}_{=0}$$

or using (10.6.15) and (10.6.16)

$$\mathcal{L}\hat{G} = \delta(x - s) - \frac{v_h(x)v_h(s)}{\int_0^L v_h^2(x)dx}. \quad (10.6.18)$$

Note that the modified Green's function is also symmetric.

To obtain the solution of (10.6.10) using the modified Green's function, we use Green's theorem with  $v = \hat{G}$ ,

$$\int_0^L \{u\mathcal{L}\hat{G} - \hat{G}\mathcal{L}u\} dx = 0 \quad (10.6.19)$$

(since  $u, \hat{G}$  satisfy the same homogeneous boundary conditions). Substituting (10.6.18) into (10.6.19) and using the properties of Dirac delta function, we have

$$u(x) = \int_0^L f(s)\hat{G}(x; s)ds + \frac{\int_0^L u(s)v_h(s)ds}{\int_0^L v_h^2(x)dx}v_h(x). \quad (10.6.20)$$

Since the last term is a multiple of the homogeneous solution (both numerator and denominator are constants), we have a particular solution for the inhomogeneous

$$u(x) = \int_0^L f(s)\hat{G}(x; s)ds. \quad (10.6.21)$$

Compare this to (10.3.35) for the case  $\lambda = 0$ .

### Example

$$u_{xx} = f(x), \quad 0 < x < 1 \quad (10.6.22)$$

$$u_x(0) = u_x(1) = 0, \quad (10.6.23)$$

$\lambda = 0$  is an eigenvalue with eigenfunction 1. Therefore

$$\int_0^1 1 \cdot f(x)dx = 0 \quad (10.6.24)$$

is necessary for the existence of a solution for (10.6.22). We can take, for example,

$$f(x) = x - \frac{1}{2} \quad (10.6.25)$$

to satisfy (10.6.24).

Now

$$\frac{d^2\hat{G}}{dx^2} = \delta(x - s) + c \cdot 1 \quad (10.6.26)$$

$$\hat{G}_x(0; s) = \hat{G}_x(1; s) = 0. \quad (10.6.27)$$

The constant  $c$  can be found by requiring

$$\int_0^1 (\delta(x - s) + c) dx = 0$$

that is

$$c = -1, \quad (10.6.28)$$

or by using (10.6.16) with  $L = 1$  and the eigenfunction  $v_h = 1$ .

Therefore

$$\frac{d^2 \hat{G}}{dx^2} = -1 \quad \text{for } x \neq s \quad (10.6.29)$$

which implies

$$\frac{d\hat{G}}{dx} = \begin{cases} -x & x < s \\ 1 - x & x > s \end{cases} \quad (10.6.30)$$

(since the constant of integration should be chosen to satisfy the boundary condition.) Integrating again, we have

$$\hat{G}(x; s) = \begin{cases} -\frac{x^2}{2} + s + C(s) & x < s \\ -\frac{x^2}{2} + x + C(s) & x > s \end{cases} \quad (10.6.31)$$

$C(s)$  is an arbitrary constant.

If we want to enforce symmetry,  $\hat{G}(x; s) = \hat{G}(s; x)$  for  $x < s$  then

$$-\frac{s^2}{2} + s + C(x) = -\frac{x^2}{2} + s + C(s)$$

or

$$C(s) = -\frac{s^2}{2} + \beta, \quad \beta \text{ is an arbitrary constant.}$$

Thus

$$\hat{G}(x; s) = \begin{cases} -\frac{x^2 + s^2}{2} + s + \beta & x < s \\ -\frac{x^2 + s^2}{2} + x + \beta & x > s \end{cases} \quad (10.6.32)$$

## Problems

1. Use Fredholm alternative to find out if

$$u_{xx} + u = \beta + x, \quad 0 < x < \pi,$$

subject to

$$u(0) = u(\pi) = 0,$$

has a solution for all  $\beta$  or only for certain values of  $\beta$ .

2. Without determining  $u(x)$ , how many solutions are there of

$$u_{xx} + \gamma u = \cos x$$

- $\gamma = 1$  and  $u(0) = u(\pi) = 0$ .
- $\gamma = 1$  and  $u_x(0) = u_x(\pi) = 0$ .
- $\gamma = -1$  and  $u(0) = u(\pi) = 0$ .
- $\gamma = 2$  and  $u(0) = u(\pi) = 0$ .

3. Are there any values of  $\beta$  for which there are solutions of

$$u_{xx} + u = \beta + x, \quad -\pi < x < \pi$$

$$u(-\pi) = u(\pi),$$

$$u_x(-\pi) = u_x(\pi)?$$

4. Consider

$$u_{xx} + u = 1$$

- Find the general solution.
- Obtain the solution satisfying

$$u(0) = u(\pi) = 0.$$

Is your answer consistent with Fredholm alternative?

- Obtain the solution satisfying

$$u_x(0) = u_x(\pi) = 0.$$

Is your answer consistent with Fredholm alternative?

5. Obtain the solution for

$$u_{xx} - u = e^x,$$



$$u(0) = 0, \quad u'(1) = 0.$$

6. Determine the modified Green's function required for

$$u_{xx} + u = F(x),$$

$$u(0) = A, \quad u(\pi) = B.$$

Assume that  $F$  satisfies the solvability condition. Obtain the solution in terms of the modified Green's function.

## 10.7 Green's Function For Poisson's Equation

In this section, we discuss the solution of Poisson's equation with either homogeneous or nonhomogeneous boundary conditions. We also solve the problem, on an infinite two dimensional domain. For more information on solution of heat conduction using Green's functions see Beck et al (1991). The book contains an extensive list of Green's functions.

To solve Poisson's equation

$$\nabla^2 u = f(\vec{r}) \quad (10.7.1)$$

subject to homogeneous boundary conditions, we generalize the idea of Green's function to higher dimensions. The Green's function must be the solution of

$$\nabla^2 G(\vec{r}; \vec{r}_0) = \delta(x - x_0)\delta(y - y_0) \quad (10.7.2)$$

where

$$\vec{r} = (x, y) \quad (10.7.3)$$

subject to the same homogeneous boundary conditions. The solution is then

$$u(\vec{r}) = \int \int f(\vec{r}_0)G(\vec{r}; \vec{r}_0)d\vec{r}_0. \quad (10.7.4)$$

To obtain Green's function, we can use one dimensional eigenfunctions (see Chapter 8). Suppose the problem is on a rectangular domain

$$\nabla^2 G = \delta(x - x_0)\delta(y - y_0), \quad 0 < x < L, \quad 0 < y < H, \quad (10.7.5)$$

$$G = 0, \quad \text{on all four sides of the rectangle} \quad (10.7.6)$$

then the eigenfunction expansion for  $G$  becomes (from (8.4.1.4))

$$G(\vec{r}; \vec{r}_0) = \sum_{n=1}^{\infty} g_n(y) \sin \frac{n\pi}{L}x, \quad (10.7.7)$$

where  $g_n(y)$  must satisfy (from (8.4.1.9))

$$\frac{d^2 g_n}{dy^2} - \left(\frac{n\pi}{L}\right)^2 g_n = \frac{2}{L} \sin \frac{n\pi}{L}x_0 \delta(y - y_0), \quad (10.7.8)$$

$$g_n(0) = g_n(H) = 0. \quad (10.7.9)$$

We rewrite (10.7.8) in the form

$$\frac{L}{2 \sin \frac{n\pi}{L}x_0} \frac{d^2 g_n}{dy^2} - \frac{L}{2 \sin \frac{n\pi}{L}x_0} \left(\frac{n\pi}{L}\right)^2 g_n = \delta(y - y_0), \quad (10.7.10)$$

to match the form of (10.4.10).

The solution is (from (8.4.1.10))

$$g_n(y) = \begin{cases} c_n \sinh \frac{n\pi}{L} y \sinh \frac{n\pi}{L} (y_0 - H) & y < y_0 \\ c_n \sinh \frac{n\pi}{L} (y - H) \sinh \frac{n\pi}{L} y_0 & y > y_0 \end{cases} \quad (10.7.11)$$

and the constant  $c_n$  is obtained from the jump condition (10.3.11)

$$\left. \frac{dg_n}{dy} \right|_{y_0^-}^{y_0^+} = -\frac{2}{L} \sin \frac{n\pi}{L} x_0 \quad (10.7.12)$$

which is  $-\frac{1}{p}$ , where  $p$  is the coefficient of  $\frac{d^2 g_n}{dy^2}$  in (10.7.10). Combining (10.7.12) and (10.7.11) we get

$$c_n \frac{n\pi}{L} \left[ \sinh \frac{n\pi}{L} y_0 \cosh \frac{n\pi}{L} (y_0 - H) - \cosh \frac{n\pi}{L} y_0 \sinh \frac{n\pi}{L} (y_0 - H) \right] = \frac{2}{L} \sin \frac{n\pi}{L} x_0.$$

The difference in brackets is  $\sinh \frac{n\pi}{L} [y_0 - (y_0 - H)] = \sinh \frac{n\pi}{L} H$ . Thus

$$c_n = \frac{2 \sin \frac{n\pi}{L} x_0}{n\pi \sinh \frac{n\pi}{L} H}. \quad (10.7.13)$$

Therefore

$$G(\vec{r}; \vec{r}_0) = \sum_{n=1}^{\infty} \frac{2 \sin \frac{n\pi}{L} x_0}{n\pi \sinh \frac{n\pi}{L} H} \sin \frac{n\pi}{L} x \begin{cases} \sinh \frac{n\pi}{L} y \sinh \frac{n\pi}{L} (y_0 - H) & y < y_0 \\ \sinh \frac{n\pi}{L} (y - H) \sinh \frac{n\pi}{L} y_0 & y > y_0 \end{cases} \quad (10.7.14)$$

Note the symmetry.

Note also that we could have used Fourier sine series in  $y$ , this will replace (10.7.7) with

$$G(\vec{r}; \vec{r}_0) = \sum_{n=1}^{\infty} h_n(x) \sin \frac{n\pi}{H} y.$$

### 10.7.1 Nonhomogeneous Boundary Conditions

To solve Poisson's equation with nonhomogeneous boundary conditions

$$\nabla^2 u = f(\vec{r}) \quad (10.7.15)$$

$$u = h(\vec{r}), \quad \text{on the boundary,} \quad (10.7.16)$$

we take the same Green's function as before

$$\nabla^2 G = \delta(x - x_0) \delta(y - y_0), \quad 0 < x < L, \quad 0 < y < H, \quad (10.7.17)$$

with homogeneous boundary conditions

$$G(\vec{r}; \vec{r}_0) = 0. \quad (10.7.18)$$

Using Green's formula

$$\iint \left( u \underbrace{\nabla^2 G}_{\delta(\vec{r}-\vec{r}_0)} - G \underbrace{\nabla^2 u}_{f(\vec{r})} \right) dx dy = \oint \left( u \nabla G - \underbrace{G}_{=0} \nabla u \right) \cdot \vec{n} ds$$

or in our case

$$\iint [u(\vec{r})\delta(\vec{r} - \vec{r}_0) - f(\vec{r})G(\vec{r}; \vec{r}_0)] dx dy = \oint h(\vec{r})\nabla G \cdot \vec{n} ds.$$

Thus, when using the properties of the Dirac delta function, we get the solution

$$u(\vec{r}_0) = \iint f(\vec{r})G(\vec{r}; \vec{r}_0) dx dy + \oint h(\vec{r})\nabla G_{\vec{r}_0} \cdot \vec{n} ds, \quad (10.7.19)$$

where  $\nabla_{\vec{r}_0}$  is the gradient with respect to  $(x_0, y_0)$  and it is called dipole source.

### 10.7.2 Two Dimensional Infinite Domain

How do we solve the problem on an infinite domain? The formulation is

$$\nabla^2 u = f, \quad \text{on infinite space with no boundary.} \quad (10.7.20)$$

Green's function should satisfy

$$\nabla^2 G = \delta(x - x_0)\delta(y - y_0), \quad \text{on infinite space with no boundary.} \quad (10.7.21)$$

The resulting Green's function in two dimensions is slightly different from the one in three dimensions. We will derive the two dimensional case and leave the other as an exercise.

Because of Symmetry  $G$  depends only on the distance  $r = |\vec{r} - \vec{r}_0|$ . Thus (10.7.21) becomes

$$\frac{1}{r} \frac{d}{dr} \left( r \frac{dG}{dr} \right) = \delta(r). \quad (10.7.22)$$

The solution is

$$G(r) = c_1 \ln r + c_2, \quad (10.7.23)$$

To obtain the constants, we integrate (10.7.21) over a circle of radius  $r$  containing the point  $(x_0, y_0)$

$$\iint \nabla^2 G dx dy = \iint \delta(x - x_0)\delta(y - y_0) dx dy = 1$$

Using Green's formula, the left hand side becomes

$$1 = \iint \nabla^2 G dx dy = \oint \nabla G \cdot \vec{n} ds = \oint \frac{\partial G}{\partial r} ds = \frac{\partial G}{\partial r} 2\pi r.$$

(Remember that the normal to the circle is in the direction of the radius  $r$ ). Thus

$$r \frac{\partial G}{\partial r} = \frac{1}{2\pi}. \quad (10.7.24)$$

Substituting  $G(r)$  from (10.7.23) we have

$$c_1 = \frac{1}{2\pi}, \quad (10.7.25)$$

$c_2$  is still arbitrary and for convenience we let  $c_2 = 0$ .

The Green's function is now

$$G(r) = \frac{1}{2\pi} \ln r. \quad (10.7.26)$$

To obtain the solution of (10.7.20), we use Green's formula again

$$\iint (u \nabla^2 G - G \nabla^2 u) dx dy = \oint (u \nabla G - G \nabla u) \cdot \vec{n} ds.$$

The closed line integral,  $\oint$ , represents integration over the entire domain, and thus we can take a circle of radius  $r$  and let  $r \rightarrow \infty$ . We would like to have a vanishing contribution from the boundary. This will require that as  $r \rightarrow \infty$ ,  $u$  will behave in such a way that

$$\lim_{r \rightarrow \infty} \oint (u \nabla G - G \nabla u) \cdot \vec{n} ds = 0$$

or

$$\lim_{r \rightarrow \infty} \oint \left( r u \frac{1}{2\pi r} - \frac{r}{2\pi} \ln r \frac{\partial u}{\partial r} \right) d\theta = 0$$

or

$$\lim_{r \rightarrow \infty} \left( u - r \ln r \frac{\partial u}{\partial r} \right) = 0. \quad (10.7.27)$$

With this, the solution is

$$u(\vec{r}) = \iint f(\vec{r}_0) G(\vec{r}; \vec{r}_0) d\vec{r}_0. \quad (10.7.28)$$

### 10.7.3 Two Dimensional Bounded Domains

The Green's function (10.7.26) is also useful in solving Poisson's equation on bounded domains. Here we discuss the following two examples.

Example Obtain Green's function for a bounded two dimensional domain subject to homogeneous boundary conditions.

We start by taking Green's function for infinite two dimensional domain and add to it a function to satisfy the boundary conditions, i.e.

$$G(\vec{r}; \vec{r}_0) = \frac{1}{2\pi} \ln |\vec{r} - \vec{r}_0| + g(\vec{r}, \vec{r}_0) \quad (10.7.29)$$

where

$$\nabla^2 g = 0 \quad (10.7.30)$$

subject to nonhomogeneous boundary conditions. For example, if  $G = 0$  on the boundary, this will mean that

$$g = -\frac{1}{2\pi} \ln |\vec{r} - \vec{r}_0|, \quad \text{on the boundary.} \quad (10.7.31)$$

The function  $g$  can be found by methods to solve Laplace's equation.

Example Solve Poisson's equation on the upper half plane,

$$\nabla^2 u = f, \quad y > 0, \quad (10.7.32)$$

subject to

$$u(x, 0) = h(x). \quad (10.7.33)$$

Green's function will have to satisfy

$$\nabla^2 G = \delta(\vec{r} - \vec{r}_0) \quad (10.7.34)$$

$$G(x, 0; x_0, y_0) = 0. \quad (10.7.35)$$

The idea here is to take the image of the source at  $(x_0, y_0)$  about the boundary  $y = 0$ . The point is  $(x_0, -y_0)$ . We now use the so called method of images. Find Green's function for the combination of the two sources, i.e.

$$\nabla^2 G = \delta(\vec{r} - \vec{r}_0) - \delta(\vec{r} - \vec{r}_0^*) \quad (10.7.36)$$

where  $\vec{r}_0^* = (x_0, -y_0)$ , is the image of  $\vec{r}_0$ .

The solution is clearly (principle of superposition) given by

$$G = \frac{1}{2\pi} \ln |\vec{r} - \vec{r}_0| - \frac{1}{2\pi} \ln |\vec{r} - \vec{r}_0^*|. \quad (10.7.37)$$

Now this function vanishes on the boundary (exercise). This is the desired Green's function since  $\delta(\vec{r} - \vec{r}_0^*) = 0$  in the upper half plane and thus (10.7.36) reduces to (10.7.34).

To solve (10.7.32)-(10.7.33) we, as usual, use Green's formula

$$\int \int (u \nabla^2 G - G \nabla^2 u) dx dy = \oint (u \nabla G - G \nabla u) \cdot \vec{n} ds = \int_{-\infty}^{\infty} \left( G \frac{\partial u}{\partial y} - u \frac{\partial G}{\partial y} \right) \Big|_{y=0} dx,$$

since the normal  $\vec{n}$  is in the direction of  $-y$ . Therefore when using (10.7.35) and the derivative of (10.7.37)

$$\frac{\partial G}{\partial y} \Big|_{y=0} = -\frac{\frac{y}{\pi}}{(x - x_0)^2 + y^2} \quad (10.7.38)$$

we get

$$u(\vec{r}) = \int \int f(\vec{r}_0) G(\vec{r}; \vec{r}_0) d\vec{r}_0 + \int_{-\infty}^{\infty} h(x_0) \frac{\frac{y}{\pi}}{(x - x_0)^2 + y^2} dx_0. \quad (10.7.39)$$

## Problems

1. Derive Green's function for Poisson's equation on infinite three dimensional space. What is the condition at infinity required to ensure vanishing contribution from the boundary integral?

2. Show that Green's function (10.7.37) satisfies the boundary condition (10.7.35).

3. Use (10.7.39) to obtain the solution of Laplace's equation on the upper half plane subject to

$$u(x, 0) = h(x)$$

4. Use the method of eigenfunction expansion to determine  $G(\vec{r}; \vec{r}_0)$  if

$$\nabla^2 G = \delta(\vec{r} - \vec{r}_0), \quad 0 < x < 1, \quad 0 < y < 1$$

subject to the following boundary conditions

$$G(0, y; \vec{r}_0) = G_x(1, y; \vec{r}_0) = G_y(x, 0; \vec{r}_0) = G_y(x, 1; \vec{r}_0) = 0$$

5. Solve the above problem inside a unit cube with zero Dirichlet boundary condition on all sides.

6. Derive Green's function for Poisson's equation on a circle by using the method of images.

7. Use the above Green's function to show that Laplace's equation inside a circle of radius  $\rho$  with

$$u(r, \theta) = h(\theta) \quad \text{for } r = \rho$$

is given by Poisson's formula

$$u(r, \theta) = \frac{1}{2\pi} \int_0^{2\pi} h(\theta_0) \frac{\rho^2 - r^2}{r^2 + \rho^2 - 2\rho r \cos(\theta - \theta_0)} d\theta_0.$$

8. Determine Green's function for the right half plane and use it to solve Poisson's equation.

9. Determine Green's function for the upper half plane subject to

$$\frac{\partial G}{\partial y} = 0 \quad \text{on } y = 0.$$

Use it to solve Poisson's equation

$$\nabla^2 u = f$$

$$\frac{\partial u}{\partial y} = h(x), \quad \text{on } y = 0.$$

Ignore the contributions at infinity.

10. Use the method of images to solve

$$\nabla^2 G = \delta(\vec{r} - \vec{r}_0)$$

in the first quadrant with  $G = 0$  on the boundary.

## 10.8 Wave Equation on Infinite Domains

Consider the wave equation

$$\frac{\partial^2 u}{\partial t^2} = c^2 \nabla^2 u + Q(\bar{x}, t) \quad (10.8.1)$$

with initial conditions

$$u(\bar{x}, 0) = f(\bar{x}) \quad (10.8.2)$$

$$u_t(\bar{x}, 0) = g(\bar{x}) \quad (10.8.3)$$

where  $\bar{x} = (x, y, z)$ . The spatial domain here is infinite, i.e.  $\bar{x} \in \mathcal{R}^3$ . The solution for semi-infinite or finite domains can be obtained using the method of images from this most general case.

If we consider a concentrated source at  $\bar{x} = \bar{x}_0 \equiv (x_0, y_0, z_0)$  and at  $t = t_0$ . The Green's function  $G(\bar{x}, t; \bar{x}_0, t_0)$  is the solution to

$$\frac{\partial^2 G}{\partial t^2} = c^2 \nabla^2 G + \delta(\bar{x} - \bar{x}_0) \delta(t - t_0). \quad (10.8.4)$$

Since the time variable increases in one direction, we require

$$G(\bar{x}, t; \bar{x}_0, t_0) = 0 \quad \text{for } t < t_0 \quad (\text{causality principle}) \quad (10.8.5)$$

We may also translate the time variable to the origin so that

$$G(\bar{x}, t; \bar{x}_0, t_0) = G(\bar{x}, t - t_0; \bar{x}_0, 0) \quad (10.8.6)$$

We will solve for the Green's function  $G$  using Fourier transforms since the domain is infinite. Hence, we need the following results about Fourier transforms:

$$f(x, y, z) = \int \int \int F(w_1, w_2, w_3) e^{-i(w_1, w_2, w_3) \cdot (x, y, z)} dw_1 dw_2 dw_3 \quad (10.8.7)$$

or

$$f(\bar{x}) = \int \int \int F(\bar{w}) e^{-i\bar{w} \cdot \bar{x}} d\bar{w}$$

and



$$F(\bar{w}) = \frac{1}{(2\pi)^3} \int \int \int f(\bar{x}) e^{i\bar{w} \cdot \bar{x}} d\bar{x} \quad \text{where} \quad d\bar{x} = dx dy dz \quad (10.8.8)$$

For the delta function, the results are

$$\mathcal{F} [\delta(\bar{x} - \bar{x}_0)] = \frac{1}{(2\pi)^3} \int \int \int \delta(\bar{x} - \bar{x}_0) e^{i\bar{w} \cdot \bar{x}} d\bar{x} = \frac{e^{i\bar{w} \cdot \bar{x}_0}}{(2\pi)^3} \quad (10.8.9)$$

and (formally)

$$\delta(\bar{x} - \bar{x}_0) = \int \int \int \frac{e^{i\bar{w} \cdot \bar{x}_0}}{(2\pi)^3} e^{-i\bar{w} \cdot \bar{x}} d\bar{w} = \frac{1}{(2\pi)^3} \int \int \int e^{-i\bar{w} \cdot (\bar{x} - \bar{x}_0)} d\bar{w}. \quad (10.8.10)$$

We take the Fourier transform of the Green's function  $\bar{G}(\bar{w}, t; \bar{x}_0, t_0)$  and solve for it from the system

$$\frac{\partial^2 G}{\partial t^2} - c^2 \nabla^2 G = \delta(\bar{x} - \bar{x}_0) \delta(t - t_0), \quad (10.8.11)$$

$$G(\bar{x}, t, \bar{x}_0, t_0) = 0 \quad \text{if} \quad t < t_0.$$

We get the following O.D.E.:

$$\frac{\partial^2 \bar{G}}{\partial t^2} + c^2 w^2 \bar{G} = \frac{e^{i\bar{w} \cdot \bar{x}_0}}{(2\pi)^3} \delta(t - t_0) \quad \text{where} \quad w^2 = \bar{w} \cdot \bar{w}, \quad (10.8.12)$$

with

$$\bar{G}(\bar{w}, t; \bar{x}_0, t_0) = 0 \quad \text{for} \quad t < t_0 \quad (10.8.13)$$

So for  $t > t_0$ ,

$$\frac{\partial^2 \bar{G}}{\partial t^2} + c^2 w^2 \bar{G} = 0, \quad (10.8.14)$$

Hence, the transform of the Green's function is

$$\bar{G} = \begin{cases} 0 & t < t_0 \\ A \cos cw(t - t_0) + B \sin cw(t - t_0) & t > t_0 \end{cases} \quad (10.8.15)$$

Since  $\bar{G}$  is continuous at  $t = t_0$ ,  $A = 0$

To solve for  $B$ , we integrate the O.D.E.

$$\int_{t_0^-}^{t_0^+} \left[ \frac{\partial^2 \bar{G}}{\partial t^2} + c^2 w^2 \bar{G} = \frac{e^{i\bar{w} \cdot \bar{x}_0}}{(2\pi)^3} \delta(t - t_0) \right] dt$$

So 
$$\frac{\partial \bar{G}}{\partial t} \Big|_{t_0^-}^{t_0^+} + 0 = \frac{e^{i\bar{w} \cdot \bar{x}_0}}{(2\pi)^3}, \quad \text{but} \quad \frac{\partial \bar{G}}{\partial t} \Big|_{t_0^-} = 0, \quad \text{so}$$

$$cwB \cos cw(t - t_0) \Big|_{t_0^-}^{t_0^+} = \frac{e^{i\bar{w} \cdot \bar{x}_0}}{(2\pi)^3} \quad \Rightarrow B = \frac{e^{i\bar{w} \cdot \bar{x}_0}}{cw(2\pi)^3}.$$

Using the inverse transform of  $\bar{G} = \frac{e^{i\bar{w} \cdot \bar{x}_0}}{cw(2\pi)^3} \sin cw(t - t_0)$ ,

we get

$$G(\bar{x}, t; \bar{x}_0, t_0) = \begin{cases} 0 & t < t_0 \\ \frac{1}{(2\pi)^3} \int_{-\infty}^{\infty} \int_{-\infty}^{\infty} \int_{-\infty}^{\infty} \frac{e^{-i\bar{w} \cdot (\bar{x} - \bar{x}_0)} \sin cw(t - t_0)}{cw} d\bar{w} & t > t_0 \end{cases} \quad (10.8.16)$$

where  $w = (w_1^2 + w_2^2 + w_3^2)^{1/2} = |\bar{w}|$

To evaluate the integral  $\frac{1}{(2\pi)^3} \int_{-\infty}^{\infty} \int_{-\infty}^{\infty} \int_{-\infty}^{\infty} \frac{e^{-i\bar{w} \cdot (\bar{x} - \bar{x}_0)} \sin cw(t - t_0)}{cw} d\bar{w}$ ,

we introduce spherical coordinates with the origin  $\bar{w} = 0$ ,  $\phi = 0$  corresponding to the  $w_3$  axis, and we integrate in the direction  $(\bar{x} - \bar{x}_0)$ . This yields  $\bar{w} \cdot (\bar{x} - \bar{x}_0) = |\bar{w}| |\bar{x} - \bar{x}_0| \cos \phi$ , and letting  $\rho = |\bar{x} - \bar{x}_0|$  we obtain  $\bar{w} \cdot (\bar{x} - \bar{x}_0) = w\rho \cos \phi$ . With the angle  $\theta$  measured from the positive  $w_1$  axis, the volume differential becomes

$$d\bar{w} \equiv dw_1 dw_2 dw_3 = w^2 \sin \phi d\phi d\theta dw,$$

and the integration limits for infinite space become  $0 < \phi < \pi$ ,  $0 < \theta < 2\pi$ ,  $0 < w < \infty$ . Our integrand is independent of  $\theta$  (based on our selection of coordinates) yielding

$$G(\bar{x}, t; \bar{x}_0, t_0) = \frac{1}{(2\pi)^2} \int_0^\infty \int_0^\pi \frac{e^{-iw\rho \cos \phi} \sin cw(t - t_0)}{cw} w^2 \sin \phi d\phi dw. \quad (10.8.17)$$

Integrating first with respect to  $\phi$

$$\begin{aligned}
G(\bar{x}, t; \bar{x}_0, t_0) &= \frac{1}{i\rho c(2\pi)^2} \int_0^\infty \sin cw(t-t_0) \int_0^\pi e^{-i w \rho \cos \phi} (i w \rho \sin \phi) d\phi dw \\
&= \frac{1}{i\rho c(2\pi)^2} \int_0^\infty \sin cw(t-t_0) \left[ e^{-i w \rho \cos \phi} \Big|_0^\pi \right] dw \\
&= \frac{1}{i\rho c(2\pi)^2} \int_0^\infty \sin cw(t-t_0) \underbrace{\left[ e^{i w \rho} - e^{-i w \rho} \right]}_{=2i \sin w \rho} dw \\
&= \frac{2}{\rho c(2\pi)^2} \int_0^\infty \sin(w\rho) \sin cw(t-t_0) dw \\
&= \frac{1}{\rho c(2\pi)^2} \int_0^\infty (\cos w [\rho - c(t-t_0)] - \cos w [\rho + c(t-t_0)]) dw
\end{aligned}$$

Since  $\frac{1}{2\pi} \int_{-\infty}^\infty e^{-i w z} dw = \delta(z)$ , using the real part of  $e^{-i w z}$  and the evenness of the cosine function we see

$$\frac{1}{\pi} \int_0^\infty \cos w z dz = \delta(z), \quad (10.8.18)$$

Hence

$$G(\bar{x}, t; \bar{x}_0, t_0) = \frac{1}{4\pi^2 \rho c} [\delta(\rho - c(t-t_0)) - \delta(\rho + c(t-t_0))] \quad \text{for } t > t_0 \quad (10.8.19)$$

Each term is a spherical impulse spreading out from  $\rho = 0$  at radial velocity of  $\pm c$ . Since the negative velocity is not physical, the second term should not be there and we get

$$G(\bar{x}, t; \bar{x}_0, t_0) = \begin{cases} 0 & t < t_0 \\ \frac{1}{4\pi^2 \rho c} \delta(\rho - c(t-t_0)) & t > t_0 \end{cases} \quad (10.8.20)$$

where  $\rho = |\bar{x} - \bar{x}_0|$

To solve the wave equation

$$\frac{\partial^2 u}{\partial t^2} = c^2 \nabla^2 u + Q(\bar{x}, t), \quad u(\bar{x}, 0) = f(\bar{x}), \quad u_t(\bar{x}, 0) = g(\bar{x}), \quad (10.8.21)$$

using Green's function, we proceed as follows.

We have a linear differential operator

$$L = \frac{\partial^2}{\partial t^2} - c^2 \nabla^2 \quad (10.8.22)$$

where

$$L = L_1 - c^2 L_2 \quad (10.8.23)$$

with

$$L_1 = \frac{\partial^2}{\partial t^2} \quad (10.8.24)$$

and

$$L_2 = \nabla^2 \quad (10.8.25)$$

We have the following Green's formulae for  $L_1$  and  $L_2$ :

$$\int_{t_1}^{t_2} [uL_1v - vL_1u] dt = uv_t - vu_t \Big|_{t_1}^{t_2}; \quad (10.8.26)$$

$$\int \int \int [uL_2v - vL_2u] d\bar{x} = \int \int (u\nabla v - v\nabla u) \cdot \bar{n} ds \quad (10.8.27)$$

Since  $Lu = Q(\bar{x}, t)$

$$\text{and } LG = \delta(\bar{x} - \bar{x}_0)\delta(t - t_0),$$

$$\text{and } uLv - vLu = uL_1v - vL_1u - c^2(uL_2v - vL_2u),$$

we see

$$\int_{t_1}^{t_2} \int \int \int [uLv - vLu] d\bar{x} dt = \int \int \int [uv_t - vu_t] \Big|_{t_1}^{t_2} d\bar{x} - c^2 \int_{t_1}^{t_2} \int \int (u\nabla v - v\nabla u) \cdot \bar{n} ds dt \quad (10.8.28)$$

It can be shown that Maxwell's reciprocity holds spatially for our Green's function, provided the elapsed times between the points  $\bar{x}$  and  $\bar{x}_0$  are the same. In fact, for the infinite domain.

$$G(\bar{x}, t; \bar{x}_0, t_0) = \begin{cases} 0 & t < t_0 \\ \frac{1}{4\pi^2 c |\bar{x} - \bar{x}_0|} \delta[|\bar{x} - \bar{x}_0| - c(t - t_0)] & t > t_0 \end{cases}$$

or

$$G(\bar{x}, t; \bar{x}_0, t_0) = \begin{cases} 0 & t < t_0 \\ \frac{1}{4\pi^2 c |\bar{x}_0 - \bar{x}|} \delta[|\bar{x}_0 - \bar{x}| - c(t_0 - t)] & t > t_0 \end{cases}$$

which is

$$= G(\bar{x}_0, t; \bar{x}, t_0) \quad (10.8.29)$$

We now let  $u = u(\bar{x}, t)$  be the solution to

$$Lu = Q(\bar{x}, t)$$

subject to

$$u(\bar{x}, 0) = f(\bar{x}), \quad u_t(\bar{x}, 0) = g(\bar{x}),$$

and

$$v = G(\bar{x}, t_0; \bar{x}_0, t) = G(\bar{x}_0, t_0; \bar{x}, t)$$

be the solution to

$$Lv = \delta(\bar{x} - \bar{x}_0)\delta(t - t_0)$$

subject to homogenous boundary condition

$$G(\bar{x}, t; \bar{x}_0, t_0) = 0, \quad \text{for } t < t_0$$

and the causality principle

$$G(\bar{x}, t_0; \bar{x}_0, t) = 0 \quad \text{for } t_0 < t$$

If we integrate in time from  $t_1 = 0$  to  $t_2 = t_0^+$  (a point just beyond the appearance of our point source at  $(t = t_0)$ ), we get

$$\begin{aligned} & \int_0^{t_0^+} \iiint \left[ u(\bar{x}, t) \underbrace{\delta(\bar{x} - \bar{x}_0)\delta(t - t_0)}_{\mathcal{L}v} - \underbrace{G(\bar{x}, t_0; \bar{x}_0, t)}_v \underbrace{Q(\bar{x}, t)}_{\mathcal{L}u} \right] d\bar{x} dt = \\ & \iiint [uG_t - Gu_t] \Big|_0^{t_0^+} d\bar{x} - c^2 \int_0^{t_0^+} \left[ \iint (u\nabla G - G\nabla u) \cdot \bar{n} ds \right] dt \end{aligned} \quad (10.8.30)$$

At  $t = t_0^+$  we have

$$G_t(\bar{x}, t_0; \bar{x}_0, t_0^+) = 0, \quad \text{since } t_0 < t_0^+$$

$$G(\bar{x}, t_0; \bar{x}_0, t_0^+) = 0, \quad \text{since } t_0 < t_0^+$$

Now using reciprocity, we see

$$\begin{aligned} u(\bar{x}_0, t_0) &= \int_0^{t_0^+} \int \int G(\bar{x}, t_0; \bar{x}_0, t) Q(\bar{x}, t) d\bar{x} dt \\ &+ \int \int \int [u_t(\bar{x}, 0) G(\bar{x}, t_0; \bar{x}_0, 0) - u(\bar{x}, 0) G_t(\bar{x}, t_0; \bar{x}_0, 0)] d\bar{x} \\ &- c^2 \int_0^{t_0^+} \left[ \int \int (u(\bar{x}, t) \nabla G(\bar{x}, t_0; \bar{x}_0, t) - G(\bar{x}, t_0; \bar{x}_0, t) \nabla u(\bar{x}, t)) \cdot \bar{n} ds \right] dt \end{aligned} \quad (10.8.31)$$

Now exchange  $\bar{x}_0$  with  $\bar{x}$  and  $t_0$  with  $t$

$$\begin{aligned} u(\bar{x}, t) &= \int_0^{t_0^+} \int \int G(\bar{x}_0, t; \bar{x}, t_0) Q(\bar{x}_0, t_0) d\bar{x}_0 dt_0 \\ &+ \int \int \int [u_t(\bar{x}_0, 0) G(\bar{x}_0, t; \bar{x}, 0) - u(\bar{x}_0, 0) G_{t_0}(\bar{x}_0, t; \bar{x}, 0)] d\bar{x}_0 \\ &- c^2 \int_0^{t_0^+} \left[ \int \int (u(\bar{x}_0, t_0) \nabla G(\bar{x}_0, t; \bar{x}, t_0) - G(\bar{x}_0, t; \bar{x}, t_0) \nabla u(\bar{x}_0, t_0)) \cdot \bar{n} ds_0 \right] dt_0 \end{aligned} \quad (10.8.32)$$

Taking the limit as  $t_0^+ \rightarrow t$  and recalling  $G(\bar{x}_0, t; \bar{x}, t_0) = G(\bar{x}, t; \bar{x}_0, t_0)$  yields

$$\begin{aligned} u(\bar{x}, t) &= \int_0^t \int \int G(\bar{x}, t; \bar{x}_0, t_0) Q(\bar{x}_0, t_0) d\bar{x}_0 dt_0 \\ &+ \int \int \int [g(\bar{x}_0) G(\bar{x}, t; \bar{x}_0, 0) - f(\bar{x}_0) G_{t_0}(\bar{x}, t; \bar{x}_0, 0)] d\bar{x}_0 \\ &- c^2 \int_0^t \left[ \int \int (u(\bar{x}_0, t_0) \nabla_{x_0} G(\bar{x}, t; \bar{x}_0, t_0) - G(\bar{x}, t; \bar{x}_0, t_0) \nabla_{x_0} u(\bar{x}_0, t_0)) \cdot \bar{n} ds_0 \right] dt_0, \end{aligned} \quad (10.8.33)$$

where  $\nabla_{x_0}$  represents the gradient with respect to the source location  $\bar{x}_0$ .

The three terms represent respectively the contributions due to the source, the initial conditions, and the boundary conditions. For our infinite domain, the last term goes away.

Hence, our complete solution for the infinite domain wave equation is given by

$$\begin{aligned}
u(\bar{x}, t) &= \frac{1}{4\pi^2 c} \int_0^t \int \int \int \frac{1}{|\bar{x} - \bar{x}_0|} \delta[|\bar{x} - \bar{x}_0| - c(t - t_0)] Q(\bar{x}_0, t_0) d\bar{x}_0 dt_0 \\
&+ \frac{1}{4\pi^2 c} \int \int \int \frac{g(\bar{x}_0)}{|\bar{x} - \bar{x}_0|} \delta[|\bar{x} - \bar{x}_0| - c(t - t_0)] - \frac{f(\bar{x}_0)}{|\bar{x} - \bar{x}_0|} \frac{\partial}{\partial t_0} \delta[|\bar{x} - \bar{x}_0| - c(t - t_0)] d\bar{x}_0 \\
&\hspace{15em} (10.8.34)
\end{aligned}$$

## 10.9 Heat Equation on Infinite Domains

Now consider the Heat Equation

$$\frac{\partial u}{\partial t} = \kappa \nabla^2 u + Q(\bar{x}, t) \quad (10.9.1)$$

with initial condition

$$u(\bar{x}, 0) = g(\bar{x}) \quad (10.9.2)$$

where  $\bar{x} = (x, y, z)$ . The spatial domain is infinite, i.e.  $\bar{x} \in \mathcal{R}^3$ . If we consider a concentrated source at  $\bar{x} = \bar{x}_0 \equiv (x_0, y_0, z_0)$  and at  $t = t_0$ , the Green's function is the solution to

$$\frac{\partial G}{\partial t} = \kappa \nabla^2 G + \delta(\bar{x} - \bar{x}_0) \delta(t - t_0) \quad (10.9.3)$$

From the causality principle

$$G(\bar{x}, t; \bar{x}_0, t_0) = 0 \quad \text{if } t < t_0 \quad (10.9.4)$$

We may also translate the time variable to the origin so

$$G(\bar{x}, t; \bar{x}_0, t_0) = G(\bar{x}, t - t_0; \bar{x}_0, 0) \quad (10.9.5)$$

We will solve for the Green's function  $G$  using Fourier transform because we lack boundary conditions. For our infinite domain, we take the Fourier transforms of the Green's function  $\bar{G}(\bar{w}, t; \bar{x}_0, t_0)$ .

We get the following O.D.E.

$$\frac{\partial \bar{G}}{\partial t} + \kappa w^2 \bar{G} = \frac{e^{i\bar{w} \cdot \bar{x}_0}}{(2\pi)^3} \delta(t - t_0) \quad (10.9.6)$$

where  $w^2 = \bar{w} \cdot \bar{w}$ ,

with

$$\bar{G}(\bar{w}, t; \bar{x}_0, t_0) = 0 \quad \text{for } t < t_0 \quad (10.9.7)$$

So, for  $t > t_0$ ,

$$\frac{\partial \bar{G}}{\partial t} + \kappa w^2 \bar{G} = 0 \quad (10.9.8)$$



Hence, the transform of the Green's function is

$$\bar{G} = \begin{cases} 0 & t < t_0 \\ Ae^{-\kappa w^2(t-t_0)} & t > t_0 \end{cases} \quad (10.9.9)$$

By integrating the ODE from  $t_0^-$  to  $t_0^+$  we get

$$\begin{aligned} \bar{G}(t_0^+) - \bar{G}(t_0^-) &= \frac{e^{i\bar{w}\cdot\bar{x}_0}}{(2\pi)^3}, \quad \text{but } \bar{G}(t_0^-) = 0, \quad \text{so} \\ A &= e^{i\bar{w}\cdot\bar{x}_0}/(2\pi)^3. \end{aligned} \quad (10.9.10)$$

Hence,

$$\bar{G}(\bar{w}, t; \bar{x}_0, t_0) = \frac{e^{i\bar{w}\cdot\bar{x}_0}}{(2\pi)^3} e^{-\kappa w^2(t-t_0)} \quad (10.9.11)$$

Using the inverse Fourier transform, we get

$$G(\bar{x}, t; \bar{x}_0, t_0) = \begin{cases} 0 & t < t_0 \\ \int_{-\infty}^{\infty} \frac{e^{-\kappa w^2(t-t_0)}}{(2\pi)^3} e^{-i\bar{w}\cdot(\bar{x}-\bar{x}_0)} d\bar{w} & t > t_0 \end{cases} \quad (10.9.12)$$

Recognizing this Fourier transform of the Green's function as a Gaussian, we obtain

$$G(\bar{x}, t; \bar{x}_0, t_0) = \begin{cases} 0 & t < t_0 \\ \frac{1}{(2\pi)^3} \left[ \frac{\pi}{\kappa(t-t_0)} \right]^{3/2} e^{-\frac{|\bar{x}-\bar{x}_0|^2}{4\kappa(t-t_0)}} & t > t_0 \end{cases} \quad (10.9.13)$$

To solve the heat equation

$$\frac{\partial u}{\partial t} = \kappa \nabla^2 u + Q(\bar{x}, t) \quad (10.9.14)$$

using Green's function we proceed as follows. We have a linear differential operator

$$L = \frac{\partial}{\partial t} - \kappa \nabla^2 \quad (10.9.15)$$

where

$$L = L_1 - \kappa L_2 \quad (10.9.16)$$

with

$$L_1 = \frac{\partial}{\partial t} \quad (10.9.17)$$

and

$$L_2 = \nabla^2. \quad (10.9.18)$$

We have the following Green's formula for  $L_2$ :

$$\int \int \int [uL_2v - vL_2u] d\bar{x} = \int \int (u\nabla v - v\nabla u) \cdot \bar{n} ds. \quad (10.9.19)$$

However, for  $L_1$ , since it is not self-adjoint, we have no such result. Nevertheless, integrating by parts, we obtain

$$\int_{t_1}^{t_2} uL_1v dt = uv \Big|_{t_1}^{t_2} - \int_{t_1}^{t_2} vL_1u dt \quad (10.9.20)$$

So that if we introduce the adjoint operator  $L_1^* = -\partial/\partial t$

We obtain

$$\int_{t_1}^{t_2} [uL_1^*v - vL_1u] = -uv \Big|_{t_1}^{t_2} \quad (10.9.21)$$

Since

$$Lu = Q(\bar{x}, t), \quad LG = \delta(\bar{x} - x_0)\delta(t - t_0), \quad (10.9.22)$$

defining

$$L^* = -\frac{\partial}{\partial t} - \kappa \nabla^2, \quad (10.9.23)$$

we see

$$\begin{aligned} \int_{t_1}^{t_2} \int \int \int [uL^*v - vL^*u] d\bar{x} dt &= - \int \int \int uv \Big|_{t_1}^{t_2} d\bar{x} + \\ &\kappa \int_{t_1}^{t_2} \int \int (v\nabla u - u\nabla v) \cdot \bar{n} ds dt. \end{aligned} \quad (10.9.24)$$

To get a representation for  $u(\bar{x}, t)$  in terms of  $G$ , we consider the source-varying Green's function, which using translation, is

$$G(\bar{x}, t_1; \bar{x}_1, t) = G(\bar{x}, -t; \bar{x}_1, -t_1) \quad (10.9.25)$$

and by causality

$$G(\bar{x}, t_1; \bar{x}_1, t) = 0 \quad \text{if } t > t_1. \quad (10.9.26)$$

Hence

$$\left( \frac{\partial}{\partial t} - \kappa \nabla^2 \right) G(\bar{x}, t_1; \bar{x}_1, t) = \delta(\bar{x} - \bar{x}_1) \delta(t - t_1) \quad (10.9.27)$$

So

$$L^* [G(\bar{x}, t_1; \bar{x}_1, t)] = \delta(\bar{x} - \bar{x}_1) \delta(t - t_1) \quad (10.9.28)$$

where  $G(\bar{x}, t_1; \bar{x}_1, t)$  is called the adjoint Green's function. Furthermore,

$$G^*(\bar{x}, t; \bar{x}_1, t_1) = G(\bar{x}, t_1; \bar{x}_1, t), \quad \text{and if } t > t_1, \quad G^* = G = 0. \quad (10.9.29)$$

We let  $u = u(\bar{x}, t)$  be the solution to  $Lu = Q(\bar{x}, t)$  subject to  $u(\bar{x}, 0) = g(\bar{x})$ ,

and  $v = G(\bar{x}, t_0; \bar{x}_0, t)$  be the source-varying Green's function satisfying

$$L^* v = \delta(\bar{x} - \bar{x}_0) \delta(t - t_0) \quad (10.9.30)$$

subject to homogenous boundary conditions and

$$G(\bar{x}, t_0; \bar{x}_0, t) = 0 \quad \text{for } t_0 > t. \quad (10.9.31)$$

Integrating from  $t_1 = 0$  to  $t_2 = t_0^+$ , our Green's formula becomes

$$\begin{aligned} & \int_0^{t_0^+} \int \int \int [u \delta(\bar{x} - \bar{x}_0) \delta(t - t_0) - G(\bar{x}, t_0; \bar{x}_0, t) Q(\bar{x}, t)] \, d\bar{x} \, dt \\ &= \int \int \int u(\bar{x}, 0) G(\bar{x}, t_0; \bar{x}_0, 0) \, d\bar{x} \\ &+ \kappa \int_0^{t_0^+} \int \int [G(\bar{x}, t_0; \bar{x}_0, t) \nabla u - u \nabla G(\bar{x}, t_0; \bar{x}_0, t)] \cdot \bar{n} \, ds \, dt. \end{aligned} \quad (10.9.32)$$

Since  $G = 0$  for  $t > t_0$ , solving for  $u(\bar{x}, t)$ , replacing the upper limit of integration  $t_0^+$  with  $t_0$ , and using reciprocity (interchanging  $\bar{x}$  and  $\bar{x}_0, t$  and  $t_0$ ) yields

$$\begin{aligned}
u(\bar{x}, t) &= \int_0^t \int \int \int G(\bar{x}, t; \bar{x}_0, t_0) Q(\bar{x}_0, t_0) d\bar{x}_0 dt_0 \\
&+ \int \int \int G(\bar{x}, t; \bar{x}_0, 0) g(\bar{x}_0) d\bar{x}_0
\end{aligned}$$

$$+ \kappa \int_0^t \int \int [G(\bar{x}, t; \bar{x}_0, t_0) \nabla_{\bar{x}_0} u(\bar{x}_0, t_0) - u(\bar{x}_0, t_0) \nabla_{\bar{x}_0} G(\bar{x}, t; \bar{x}_0, t_0)] \cdot \bar{n} ds_0 dt_0 \quad (10.9.33)$$

From our previous result, the solution for the infinite domain heat equation is given by

$$\begin{aligned}
u(\bar{x}, t) &= \int_0^{t_0} \int \int \int \left[ \frac{1}{4\pi\kappa(t-t_0)} \right]^{3/2} e^{-\frac{|\bar{x}-\bar{x}_0|^2}{4\kappa(t-t_0)}} Q(\bar{x}_0, t_0) d\bar{x}_0 dt_0 \\
&+ \int \int \int f(\bar{x}_0) \left( \frac{1}{4\pi\kappa t} \right)^{3/2} e^{-\frac{|x-x_0|^2}{4\kappa t}} d\bar{x}_0
\end{aligned} \quad (10.9.34)$$

## 10.10 Green's Function for the Wave Equation on a Cube

Solving the wave equation in  $\mathcal{R}^3$  with Cartesian coordinates, we select a rectangular domain

$$\mathcal{D} = \{\bar{x} = (x, y, z) : x \in [0, \alpha], y \in [0, \beta], z \in [0, \gamma]\}$$

So that the wave equation is

$$\frac{\partial^2 u(\bar{x}, t)}{\partial t^2} - c^2 \nabla^2 u(\bar{x}, t) = Q(\bar{x}, t) \quad \bar{x} \in \mathcal{D}, \quad t > 0 \quad (10.10.1)$$

$$u(\bar{x}, t) = f(\bar{x}, t) \quad \bar{x} \in \partial \mathcal{D} \quad (10.10.2)$$

$$u(\bar{x}, 0) = g(\bar{x}), \quad \bar{x} \in \mathcal{D} \quad (10.10.3)$$

$$u_t(\bar{x}, 0) = h(\bar{x}) \quad \bar{x} \in \mathcal{D} \quad (10.10.4)$$

Defining the wave operator

$$L = \frac{\partial^2}{\partial t^2} - c^2 \nabla^2 \quad (10.10.5)$$

we seek a Green's function  $G(\bar{x}, t; \bar{x}_0, t_0)$  such that

$$L[G(\bar{x}, t; \bar{x}_0, t_0)] = \delta(\bar{x} - \bar{x}_0) \delta(t - t_0) \quad (10.10.6)$$

Also,

$$G(\bar{x}, t; \bar{x}_0, t_0) = 0 \quad \text{if} \quad t < t_0 \quad (10.10.7)$$

$$G(\bar{x}, t_0^+; \bar{x}_0, t_0) = 0, \quad (10.10.8)$$

and

$$G_t(\bar{x}, t_0^+; \bar{x}_0, t_0) = \delta(\bar{x} - \bar{x}_0) \quad (10.10.9)$$

We require the translation property

$$G(\bar{x}, t; \bar{x}_0, t_0) = G(\bar{x}, t - t_0; \bar{x}_0, 0) \quad (10.10.10)$$

and spatial symmetry

$$G(\bar{x}, t - t_0; \bar{x}_0, 0) = G(\bar{x}_0, t - t_0; \bar{x}, 0) \quad (10.10.11)$$

provided the difference  $t - t_0$  is the same in each case.

We have shown that the solution to the wave equation is

$$\begin{aligned} u(\bar{x}, t) &= \int_0^t \int \int \int_D G(\bar{x}, t; \bar{x}_0, t_0) Q(\bar{x}_0, t_0) d\bar{x}_0 dt_0 \\ &+ \int \int \int_D [h(\bar{x}_0)G(\bar{x}, t; \bar{x}_0, 0) - g(\bar{x}_0)G_{t_0}(\bar{x}, t; \bar{x}_0, 0)] d\bar{x}_0 \end{aligned} \quad (10.10.12)$$

$$-c^2 \int_0^t \left\{ \int \int_{\partial D} f(\bar{x}_0, t_0) \nabla_{\bar{x}_0} G(\bar{x}, t; \bar{x}_0, t_0) - G(\bar{x}, t; \bar{x}_0, t_0) \nabla_{\bar{x}_0} f(\bar{x}_0, t_0) \right\} \cdot \bar{n} ds_0 \Big] dt_0$$

We therefore must find the Green's function to solve our problem. We begin by finding the Green's function for the Helmholtz operator

$$\hat{L}u \equiv \nabla^2 u + c^2 u = 0 \quad (10.10.13)$$

Where  $u$  is now a spatial function of  $\bar{x}$  on  $\mathcal{D}$ . The required Green's function  $G_c(\bar{x}, \bar{x}_0)$  satisfies

$$\nabla^2 G_c + c^2 G_c = \delta(\bar{x} - \bar{x}_0) \quad (10.10.14)$$

with homogeneous boundary conditions

$$G_c(\bar{x}) = 0 \quad \text{for } \bar{x} \in \partial \mathcal{D} \quad (10.10.15)$$

We will use eigenfunction expansion to find the Green's function for the Helmholtz equation. We let the eigenpairs  $\{\phi_N, \lambda_N\}$  be such that

$$\nabla^2 \phi_N + \lambda_N^2 \phi_N = 0 \quad (10.10.16)$$

Hence the eigenfunctions are

$$\phi_{\ell mn}(x, y, z) = \sin\left(\frac{\ell\pi x}{\alpha}\right) \sin\left(\frac{m\pi y}{\beta}\right) \sin\left(\frac{n\pi z}{\gamma}\right) \quad (10.10.17)$$

and the eigenvalues are

$$\lambda_{\ell mn} = \pi^2 \left[ \left(\frac{\ell}{\alpha}\right)^2 + \left(\frac{m}{\beta}\right)^2 + \left(\frac{n}{\gamma}\right)^2 \right] \quad \text{for } \ell, m, n = 1, 2, 3, \dots \quad (10.10.18)$$

We know that these eigenfunctions form a complete, orthonormal set which satisfy the homogeneous boundary conditions on  $\partial\mathcal{D}$ . Since  $G_c$  also satisfies the homogeneous boundary conditions, we expand  $G_c$  in terms of the eigenfunctions  $\phi_N$ , where  $N$  represents the index set  $\{\ell, m, n\}$ , so that

$$G_c(\bar{x}; \bar{x}_0) = \sum_N A_N \phi_N(\bar{x}) \quad (10.10.19)$$

Substituting into the PDE (10.10.14) we see

$$\sum_N A_N (c^2 - \lambda_N^2) \phi_N(\bar{x}) = \delta(\bar{x} - \bar{x}_0) \quad (10.10.20)$$

If we multiply the above equation by  $\bar{\phi}_M$  and integrate over  $\mathcal{D}$ , using the fact that

$$\int \int \int_D \phi_N \bar{\phi}_M d\bar{x} = \delta_{NM} \quad (10.10.21)$$

$$A_N = \frac{\bar{\phi}_N(\bar{x}_0)}{c^2 - \lambda_N^2} \quad (10.10.22)$$

So that

$$G_c(\bar{x}; \bar{x}_0) = \sum_N \frac{\bar{\phi}_N(\bar{x}_0) \phi_N(\bar{x})}{c^2 - \lambda_N^2} \quad (10.10.23)$$

There are two apparent problems with this form. The first is, it appears to not be symmetric in  $\bar{x}$  and  $\bar{x}_0$ ; However, if we note that the Helmholtz equation involved no complex numbers explicitly,  $\phi_N$  and  $\bar{\phi}_N$  are distinct eigenfunctions corresponding to the eigenvalue  $\lambda_N$  and

that the above expansion contains both the terms  $\frac{\bar{\phi}_N(\bar{x}_0)\phi_N(\bar{x})}{c^2 - \lambda_N^2}$  and  $\frac{\phi_N(\bar{x}_0)\bar{\phi}_N(\bar{x})}{c^2 - \lambda_N^2}$ , so that the Green's function is, in fact, symmetric and real.

We also see a potential problem when  $\lambda_N^2 = c^2$ . As a function of  $c$ ,  $G_c$  is analytic except for simple poles at  $c = \pm\lambda_N$ , for which we have nontrivial solutions to the homogeneous Helmholtz equation we must use modified Green's functions as before when zero was an eigenvalue.

We now use the Green's function for the Helmholtz equation to find  $G(\bar{x}, t; \bar{x}_0, t_0)$ , the Green's function for the wave equation. We notice that  $G_c(\bar{x}; \bar{x}_0)e^{-ic^2t}$  is a solution of the wave equation for a point source located at  $\bar{x}_0$ , since

$$\begin{aligned} \frac{\partial^2}{\partial t^2} [G_c e^{-ic^2t}] - c^2 \nabla_{\bar{x}}^2 [G_c e^{-ic^2t}] &= -c^4 G_c e^{-ic^2t} - c^2 [-c^2 + \delta(\bar{x} - \bar{x}_0)] e^{-ic^2t} \\ &= -c^2 \delta(\bar{x} - \bar{x}_0) e^{-ic^2t} \end{aligned} \quad (10.10.24)$$

So that

$$\nabla_{\bar{x}}^2 [G_c e^{-ic^2t}] - \frac{1}{c^2} \frac{\partial^2}{\partial t^2} [G_c e^{-ic^2t}] = \delta(\bar{x} - \bar{x}_0) e^{-ic^2t} \quad (10.10.25)$$

Using the integral representation of the  $\delta$  function

$$\delta(t - t_0) = \frac{1}{2\pi} \int_{-\infty}^{\infty} e^{-icw(t-t_0)} dw \quad (10.10.26)$$

and using linearity we obtain

$$G(\bar{x}, t; \bar{x}_0, t_0) = \frac{1}{2\pi} \int_{-\infty}^{\infty} G_c(\bar{x}; \bar{x}_0) e^{-ic^2(t-t_0)} d(c^2) \quad (10.10.27)$$

Although we have a form for the Green's function, recalling the form for  $G_c$ , we note we cannot integrate along the real axis due to the poles at the eigenvalues  $\pm\lambda_N$ . If we write the expansion for  $G_c$  we get

$$G(\bar{x}, t; \bar{x}_0, t_0) = \frac{1}{2\pi} \int_{-\infty}^{\infty} \sum_N \frac{\phi_N(\bar{x})\bar{\phi}_N(\bar{x}_0)}{c^2 - \lambda_N^2} e^{-ic^2(t-t_0)} d(c^2) \quad (10.10.28)$$

Changing variables with  $w_N = c\lambda_N$ ,  $w = c^2$



$$G(\bar{x}, t; \bar{x}_0, t_0) = \frac{c^2}{2\pi} \sum_N \phi_N(\bar{x}) \bar{\phi}_N(\bar{x}_0) \int_{-\infty}^{\infty} \frac{e^{-iw(t-t_0)}}{w_N^2 - w^2} dw, \quad (10.10.29)$$

We must integrate along a contour so that  $G(\bar{x}, t; \bar{x}_0, t_0) = 0$  when  $t > t_0$ , so we select  $x + \epsilon i$   $x \in (-\infty, \infty)$  as the contour. For  $t > t_0$ , we close the contour with an (infinite) semi-circle in the lower half-plane without changing the value of the integral, and using Cauchy's formula we obtain  $\frac{2\pi}{w_N} \sin[w_N(t - t_0)]$ . If  $t < t_0$ , we close the contour with a semi-circle in the upper half-plane in which there are no poles, and the integral equals zero.

Hence

$$G(\bar{x}, t; \bar{x}_0, t_0) = c^2 \sum_N \frac{\sin[w_N(t - t_0)]}{w_N} H(t - t_0) \bar{\phi}_N(\bar{x}_0) \phi_N(\bar{x}) \quad (10.10.30)$$

where  $H$  is the Heaviside function, and  $w_N = c\lambda_N$ .

## SUMMARY

Let  $\mathcal{L}y = -(py')' + qy$ .

- To get Green's function for  $\mathcal{L}y = f$ ,  $0 < x < 1$ ,

$$y(0) - h_0y'(0) = y(1) - h_1y'(1) = 0.$$

Step 1: Solve

$$\mathcal{L}u = 0, \quad u(0) - h_0u'(0) = 0,$$

and

$$\mathcal{L}v = 0, \quad v(1) - h_1v'(1) = 0.$$

Step 2:

$$G(x; s) = \begin{cases} u(s)v(x) & 0 \leq s \leq x \leq 1 \\ u(x)v(s) & 0 \leq x \leq s \leq 1. \end{cases}$$

Step 3:

$$y = \int_0^1 G(x; s)f(s)ds,$$

where

$$\mathcal{L}G = \delta(x - s).$$

$G$  satisfies homogeneous boundary conditions and a jump

$$\frac{\partial G(s^+; s)}{\partial x} - \frac{\partial G(s^-; s)}{\partial x} = -\frac{1}{p(s)}.$$

- To solve  $\mathcal{L}y - \lambda ry = f$ ,  $0 < x < 1$ ,

$$y(x) = \lambda \int_0^1 G(x; s)r(s)y(s)ds + F(x),$$

where

$$F(x) = \int_0^1 G(x; s)f(s)ds.$$

- Properties of Dirac delta function
- Fredholm alternative

- To solve  $\mathcal{L}u = f$ ,  $0 < x < 1$ ,  $u(0) = A$ ,  $u(1) = B$ ,  
and  $\lambda = 0$  is not an eigenvalue:

Find  $G$  such that

$$\mathcal{L}G = \delta(x - s), \quad G(0; s) = A, \quad G(1; s) = B.$$

$$u(s) = \int_0^1 G(x; s)f(x)dx + BG_x(1; s) - AG_x(0; s)$$

- To solve  $\mathcal{L}u = f$ ,  $0 < x < 1$  subject to homogeneous boundary conditions  
and  $\lambda = 0$  is an eigenvalue:

Find  $\hat{G}$  such that

$$\mathcal{L}\hat{G} = \delta(x - s) - \frac{v_h(x)v_h(s)}{\int_0^L v_h^2(x)dx},$$

where  $v_h$  is the solution of the homogeneous

$$\mathcal{L}v_h = 0,$$

The solution is

$$u(x) = \int_0^L f(s)\hat{G}(x; s)ds.$$

- Solution of Poisson's equation

$$\nabla^2 u = f(\vec{r})$$

subject to homogeneous boundary conditions.

The Green's function must be the solution of

$$\nabla^2 G(\vec{r}; \vec{r}_0) = \delta(x - x_0)\delta(y - y_0)$$

where

$$\vec{r} = (x, y)$$

subject to the same homogeneous boundary conditions.

The solution is then

$$u(\vec{r}) = \int \int f(\vec{r}_0)G(\vec{r}; \vec{r}_0)d\vec{r}_0.$$

- To solve Poisson's equation with nonhomogeneous boundary conditions

$$\nabla^2 u = f(\vec{r})$$

$$u = h(\vec{r}), \quad \text{on the boundary,}$$

Green's function as before

$$\nabla^2 G = \delta(x - x_0)\delta(y - y_0),$$

with homogeneous boundary conditions

$$G(\vec{r}; \vec{r}_0) = 0.$$

The solution is then

$$u(\vec{r}) = \iint f(\vec{r}_0)G(\vec{r}; \vec{r}_0)d\vec{r}_0 + \oint h(\vec{r}_0)\nabla G \cdot \vec{n}ds.$$

- To solve

$$\nabla^2 u = f, \quad \text{on infinite space with no boundary.}$$

Green's function should satisfy

$$\nabla^2 G = \delta(x - x_0)\delta(y - y_0), \quad \text{on infinite space with no boundary.}$$

For 2 dimensions

$$G(r) = \frac{1}{2\pi} \ln r,$$

$$\lim_{r \rightarrow \infty} \left( u - r \ln r \frac{\partial u}{\partial r} \right) = 0.$$

$$u(\vec{r}) = \iint f(\vec{r}_0)G(\vec{r}; \vec{r}_0)d\vec{r}_0.$$

For 3 dimensional space

$$G = -\frac{1}{4\pi}r.$$

For upper half plane

$$G = \frac{1}{4\pi} \ln \frac{(x - x_0)^2 + (y - y_0)^2}{(x - x_0)^2 + (y + y_0)^2}, \quad \text{method of images}$$

$$u(\vec{r}) = \iint f(\vec{r}_0)G(\vec{r}; \vec{r}_0)d\vec{r}_0 + \int_{-\infty}^{\infty} h(x_0) \frac{\frac{y}{\pi}}{(x - x_0)^2 + y^2} dx_0.$$

- To solve the wave equation on infinite domains

$$\frac{\partial^2 u}{\partial t^2} = c^2 \nabla^2 u + Q(\bar{x}, t)$$

$$u(\bar{x}, 0) = f(\bar{x})$$

$$u_t(\bar{x}, 0) = g(\bar{x})$$

$$G(\bar{x}, t; \bar{x}_0, t_0) = \begin{cases} 0 & t < t_0 \\ \frac{1}{4\pi^2 \rho c} \delta(\rho - c(t - t_0)) & t > t_0 \end{cases}$$

$$u(\bar{x}, t) = \frac{1}{4\pi^2 c} \int_0^t \iiint \frac{1}{|\bar{x} - \bar{x}_0|} \delta[|\bar{x} - \bar{x}_0| - c(t - t_0)] Q(\bar{x}_0, t_0) d\bar{x}_0 dt_0$$

$$+ \frac{1}{4\pi^2 c} \iiint \frac{g(\bar{x}_0)}{|\bar{x} - \bar{x}_0|} \delta[|\bar{x} - \bar{x}_0| - c(t - t_0)] - \frac{f(\bar{x}_0)}{|\bar{x} - \bar{x}_0|} \frac{\partial}{\partial t_0} \delta[|\bar{x} - \bar{x}_0| - c(t - t_0)] d\bar{x}_0$$

- To solve the heat equation on infinite domains

$$\frac{\partial u}{\partial t} = \kappa \nabla^2 u + Q(\bar{x}, t)$$

$$u(\bar{x}, 0) = g(\bar{x})$$

$$G(\bar{x}, t; \bar{x}_0, t_0) = \begin{cases} 0 & t < t_0 \\ \frac{1}{(2\pi)^3} \left[ \frac{\pi}{\kappa(t - t_0)} \right]^{3/2} e^{-\frac{|\bar{x} - \bar{x}_0|^2}{4\kappa(t - t_0)}} & t > t_0 \end{cases}$$

$$u(\bar{x}, t) = \int_0^{t_0} \iiint \left[ \frac{1}{4\pi\kappa(t - t_0)} \right]^{3/2} e^{-\frac{|\bar{x} - \bar{x}_0|^2}{4\kappa(t - t_0)}} Q(\bar{x}_0, t_0) d\bar{x}_0 dt_0$$

$$+ \iiint f(\bar{x}_0) \left( \frac{1}{4\pi\kappa t} \right)^{3/2} e^{-\frac{|\bar{x} - \bar{x}_0|^2}{4\kappa t}} d\bar{x}_0$$

- To solve the Wave Equation on a Cube

$$\frac{\partial^2 u(\bar{x}, t)}{\partial t^2} - c^2 \nabla^2 u(\bar{x}, t) = Q(\bar{x}, t) \quad \bar{x} \in \mathcal{D}, \quad t > 0$$

$$u(\bar{x}, t) = f(\bar{x}, t) \quad \bar{x} \in \partial \mathcal{D}$$

$$u(\bar{x}, 0) = g(\bar{x}), \quad \bar{x} \in \mathcal{D}$$

$$u_t(\bar{x}, 0) = h(\bar{x}) \quad \bar{x} \in \mathcal{D}$$

$$\mathcal{D} = \{\bar{x} = (x, y, z) : x \in [0, \alpha], y \in [0, \beta], z \in [0, \gamma]\}$$

$$G(\bar{x}, t; \bar{x}_0, t_0) = c^2 \sum_N \frac{\sin[w_N(t - t_0)]}{w_N} H(t - t_0) \bar{\phi}_N(\bar{x}_0) \phi_N(\bar{x})$$

where  $H$  is the Heaviside function,  $w_N = c\lambda_N$ , and  $\lambda_N$  and  $\phi_N$  are the eigenvalues and eigenfunctions of Helmholtz equation.

$$\begin{aligned} u(\bar{x}, t) &= \int_0^t \int \int \int_D G(\bar{x}, t; \bar{x}_0, t_0) Q(\bar{x}_0, t_0) d\bar{x}_0 dt_0 \\ &+ \int \int \int_D [h(\bar{x}_0) G(\bar{x}, t; \bar{x}_0, 0) - g(\bar{x}_0) G_{t_0}(\bar{x}, t; \bar{x}_0, 0)] d\bar{x}_0 \end{aligned}$$

$$-c^2 \int_0^t \left\{ \int \int_{\partial D} f(\bar{x}_0, t_0) \nabla_{\bar{x}_0} G(\bar{x}, t; \bar{x}_0, t_0) - G(\bar{x}, t; \bar{x}_0, t_0) \nabla_{\bar{x}_0} f(\bar{x}_0, t_0) \cdot \bar{n} ds_0 \right\} dt_0$$

# 11 Laplace Transform

## 11.1 Introduction

Laplace transform has been introduced in an ODE course, and is used especially to solve ODEs having pulse sources. In this chapter we review the Laplace transform and its properties and show how it is used in analyzing PDEs. It should be noted that most problems that can be analyzed by Laplace transform, can also be analyzed by one of the other techniques in this book.

Definition 22: The Laplace transform of a function  $f(t)$ , denoted by  $\mathcal{L}[f(t)]$  is defined by

$$\mathcal{L}[f] = \int_0^{\infty} f(t)e^{-st}dt, \quad (11.1.1)$$

assuming the integral converges (real part of  $s > 0$ ).

We will denote the Laplace transform of  $f$  by  $F(s)$ , exactly as with Fourier transform. The Laplace transform of some elementary functions can be obtained by definition. See Table at the end of this Chapter.

The inverse transform is given by

$$f(t) = \mathcal{L}^{-1}[F(s)] = \frac{1}{2\pi i} \int_{\gamma-i\infty}^{\gamma+i\infty} F(s)e^{st}ds, \quad (11.1.2)$$

where  $\gamma$  is chosen so that  $f(t)e^{-\gamma t}$  decays sufficiently rapidly as  $t \rightarrow \infty$ , i.e. we have to compute a line integral in the complex  $s$ -plane.

From the theory of complex variables, it can be shown that the line integral is to the right of all singularities of  $F(s)$ . To evaluate the integral we need Cauchy's theorem from the theory of functions of a complex variable which states that if  $f(s)$  is analytic (no singularities) at all points inside and on a closed contour  $C$ , then the closed line integral is zero,

$$\oint_C f(s)ds = 0. \quad (11.1.3)$$

If the function has singularities at  $s_n$ , then we use the Residue theorem,

$$\frac{1}{2\pi i} \oint_C F(s)e^{st}ds = \sum_n \text{residue} (F(s_n)e^{snt}). \quad (11.1.4)$$

Example If  $F(s) = \frac{P(s)}{Q(s)}$  has simple poles at  $s_n$  (i.e.  $Q(s_n) = 0$ ,  $s_n$  all simple zeros), then

$$\text{residue} (F(s_n)e^{snt}) = \frac{P(s_n)}{Q'(s_n)}e^{snt}.$$

Example Find  $\mathcal{L}^{-1} \left[ \frac{s^2 + 2s + 4}{s(s^2 + 1)} \right]$ .

The zeros of denominator are  $s = 0, \pm i$ . The residues are

$$\begin{aligned} f(t) &= \frac{4}{1}e^0 + \frac{i^2 + 2i + 4}{2i \cdot i}e^{it} + \frac{(-i)^2 - 2i + 4}{-2i \cdot i}e^{-it} \\ &= 4 - \frac{3 + 2i}{2}e^{it} - \frac{3 - 2i}{2}e^{-it} \\ &= 4 - 3 \cos t + 2 \sin t \end{aligned}$$

We can use the table and partial fractions to get the same answer.

Laplace transform of derivatives

$$\begin{aligned} \mathcal{L} \left[ \frac{df}{dt} \right] &= \int_0^\infty \frac{df}{dt} e^{-st} dt \\ &= f(t)e^{-st} \Big|_0^\infty + s \int_0^\infty f(t)e^{-st} dt \\ &= sF(s) - f(0) \end{aligned} \tag{11.1.5}$$

$$\begin{aligned} \mathcal{L} \left[ \frac{d^2 f}{dt^2} \right] &= s \mathcal{L} \left[ \frac{df}{dt} \right] - f'(0) \\ &= s [sF(s) - f(0)] - f'(0) \\ &= s^2 F(s) - sf(0) - f'(0) \end{aligned} \tag{11.1.6}$$

Convolution theorem

$$\mathcal{L}^{-1} [F(s)G(s)] = g * f = \int_0^t g(\tau) f(t - \tau) d\tau. \tag{11.1.7}$$

Dirac delta function

$$\mathcal{L} [\delta(t - a)] = \int_0^\infty \delta(t - a) e^{-st} dt = e^{-sa}, \quad a > 0, \tag{11.1.8}$$

therefore

$$\mathcal{L} [\delta(t)] = 1. \tag{11.1.9}$$

Example Use Laplace transform to solve

$$y'' + 4y = \sin 3x, \tag{11.1.10}$$

$$y(0) = y'(0) = 0. \tag{11.1.11}$$



Taking Laplace transform and using the initial conditions we get

$$s^2Y(s) + 4Y(s) = \frac{3}{s^2 + 9}.$$

Thus

$$Y(s) = \frac{3}{(s^2 + 9)(s^2 + 4)}. \quad (11.1.12)$$

The method of partial fractions yields

$$Y(s) = \frac{3/5}{s^2 + 4} - \frac{3/5}{s^2 + 9} = \frac{3}{10} \frac{2}{s^2 + 2^2} - \frac{1}{5} \frac{3}{s^2 + 3^2}.$$

Using the table, we have

$$y(x) = \frac{3}{10} \sin 2x - \frac{1}{5} \sin 3x. \quad (11.1.13)$$

Example Consider a mass on a spring with  $m = k = 1$  and  $y(0) = y'(0) = 0$ . At each of the instants  $t = n\pi$ ,  $n = 0, 1, 2, \dots$  the mass is struck a hammer blow with a unit impulse. Determine the resulting motion.

The initial value problem is

$$y'' + y = \sum_{n=0}^{\infty} \delta(t - n\pi), \quad (11.1.14)$$

$$y(0) = y'(0) = 0. \quad (11.1.15)$$

The transformed equation is

$$s^2Y(s) + Y(s) = \sum_{n=0}^{\infty} e^{-n\pi s}.$$

Thus

$$Y(s) = \sum_{n=0}^{\infty} \frac{e^{-n\pi s}}{s^2 + 1}, \quad (11.1.16)$$

and the inverse transform

$$y(t) = \sum_{n=0}^{\infty} H(t - n\pi) \sin(t - n\pi). \quad (11.1.17)$$

## Problems

1. Use the definition to find Laplace transform of each

- a. 1.
- b.  $e^{\omega t}$ .
- c.  $\sin \omega t$ .
- d.  $\cos \omega t$ .
- e.  $\sinh \omega t$ .
- f.  $\cosh \omega t$ .
- g.  $H(t - a)$ ,  $a > 0$ .

2. Prove the following properties

- a.  $\mathcal{L}[-tf(t)] = \frac{dF}{ds}$ .
- b.  $\mathcal{L}[e^{at}f(t)] = F(s - a)$ .
- c.  $\mathcal{L}[H(t - a)f(t - a)] = e^{-as}F(s)$ ,  $a > 0$ .

3. Use the table of Laplace transforms to find

- a.  $t^3 e^{-2t}$ .
- b.  $t \sin 2t$ .
- c.  $H(t - 1)$ .
- d.  $e^{2t} \sin 5t$ .
- e.  $te^{-2t} \cos t$ .
- f.  $t^2 H(t - 2)$ .

g.

$$\begin{cases} 0 & t < 1 \\ t^2 & 1 < t < 2 \\ t & 2 < t \end{cases}$$

4. Find the inverse Laplace transform for each

- a.  $\frac{1}{s^2 + 4}$ .
- b.  $\frac{e^{-3s}}{s^2 - 4}$ .

c.  $\frac{s}{s^2 + 8s + 7}$ .

d.  $\frac{2s - 1}{s^2 - 4s + 9}$ .

e.  $\frac{s}{s^2 - 4s - 5}$ .

5. Use the tables to find the inverse Laplace transform

a.  $\frac{1}{(s + 1)^2}$ .

b.  $\frac{1}{(s^2 + 1)^2}$ .

c.  $\frac{s + 2}{s(s^2 + 9)} (1 - 5e^{-4s})$ .

6. Solve the following ODEs

a.  $\frac{dy}{dt} + y = 1, \quad y(0) = 2.$

b.  $\frac{dy}{dt} + 3y = \begin{cases} 4e^{-t} & t < 8 \\ 2 & t > 8 \end{cases}$

$y(0) = 1.$

c.  $\frac{d^2y}{dt^2} + y = \cos t, \quad y(0) = y'(0) = 0.$

## 11.2 Solution of Wave Equation

In this section, we show how to use Laplace transform to solve the one dimensional wave equation in the semi-infinite and finite domain cases.

Consider the vibrations of a semi-infinite string caused by the boundary condition, i.e.

$$u_{tt} - c^2 u_{xx} = 0, \quad 0 < x < \infty, \quad t > 0, \quad (11.2.1)$$

$$u(x, 0) = 0, \quad (11.2.2)$$

$$u_t(x, 0) = 0, \quad (11.2.3)$$

$$u(0, t) = f(t). \quad (11.2.4)$$

A boundary condition at infinity would be

$$\lim_{x \rightarrow \infty} u(x, t) = 0. \quad (11.2.5)$$

Using Laplace transform for the time variable, we get upon using the zero initial conditions,

$$s^2 U(x, s) - c^2 U_{xx} = 0. \quad (11.2.6)$$

This is an ordinary differential equation in  $x$  (assuming  $s$  is fixed). Transforming the boundary conditions,

$$U(0, s) = F(s), \quad (11.2.7)$$

$$\lim_{x \rightarrow \infty} U(x, s) = 0. \quad (11.2.8)$$

The general solution of (11.2.6) subject to the boundary conditions (11.2.7)-(11.2.8) is

$$U(x, s) = F(s)e^{-\frac{x}{c}s}. \quad (11.2.9)$$

To invert this transform, we could use the table

$$u(x, t) = H\left(t - \frac{x}{c}\right) f\left(t - \frac{x}{c}\right). \quad (11.2.10)$$

The solution is zero for  $x > ct$ , since the force at  $x = 0$  causes a wave travelling at speed  $c$  to the right and it could not reach a point  $x$  farther than  $ct$ .

Another possibility to invert the transform is by using the convolution theorem. This requires the knowledge of the inverse of  $e^{-\frac{x}{c}s}$ , which is  $\delta\left(t - \frac{x}{c}\right)$ . Thus

$$u(x, t) = \int_0^t f(\tau) \delta\left(t - \frac{x}{c} - \tau\right) d\tau = \begin{cases} 0 & t < \frac{x}{c} \\ f\left(t - \frac{x}{c}\right) & t > \frac{x}{c} \end{cases},$$

which is the same as (11.2.10).

We now turn to the vibrations of a finite string,

$$u_{tt} - c^2 u_{xx} = 0, \quad 0 < x < L, \quad t > 0, \quad (11.2.11)$$

$$u(x, 0) = 0, \quad (11.2.12)$$

$$u_t(x, 0) = 0, \quad (11.2.13)$$

$$u(0, t) = 0, \quad (11.2.14)$$

$$u(L, t) = b(t). \quad (11.2.15)$$

The Laplace transform will lead to the ODE

$$s^2 U(x, s) - c^2 U_{xx} = 0, \quad (11.2.16)$$

$$U(0, s) = 0, \quad (11.2.17)$$

$$U(L, s) = B(s), \quad (11.2.18)$$

for which the solution is

$$V(x, s) = B(s) \frac{\sinh s \frac{x}{c}}{\sinh s \frac{L}{c}}. \quad (11.2.19)$$

In order to use the convolution theorem, we need to find the inverse transform of

$$G(x, s) = \frac{\sinh s \frac{x}{c}}{\sinh s \frac{L}{c}}. \quad (11.2.20)$$

Using (11.1.2) and (11.1.4) we have

$$g(x, t) = \frac{1}{2\pi i} \int_{\gamma-i\infty}^{\gamma+i\infty} \frac{\sinh s \frac{x}{c}}{\sinh s \frac{L}{c}} e^{st} ds = \sum_n \text{residue} \left( G(x, s_n) e^{s_n t} \right). \quad (11.2.21)$$

The zeros of denominator are given by

$$\sinh \frac{L}{c} s = 0, \quad (11.2.22)$$

and all are imaginary,

$$i \frac{L}{c} s_n = n\pi, \quad n = \pm 1, \pm 2, \dots$$

or

$$s_n = -in\pi \frac{c}{L}, \quad n = \pm 1, \pm 2, \dots \quad (11.2.23)$$

The case  $n = 0$  does not yield a pole since the numerator is also zero.

$$g(x, t) = \sum_{n=-\infty}^{-1} \frac{\sinh \frac{x}{c} (-in\pi \frac{c}{L})}{\frac{L}{c} \cosh \frac{L}{c} (-in\pi \frac{c}{L})} e^{in\pi \frac{c}{L} t} + \sum_{n=1}^{\infty} \frac{\sinh \frac{x}{c} (-in\pi \frac{c}{L})}{\frac{L}{c} \cosh \frac{L}{c} (-in\pi \frac{c}{L})} e^{in\pi \frac{c}{L} t}$$

Using the relationship between the hyperbolic and circular functions

$$\sinh(\pm ix) = \pm i \sin x, \quad \cosh(\pm ix) = \cos x, \quad (11.2.24)$$

we have after we take  $m = -n$  in the first sum

$$g(x, t) = \sum_{m=1}^{\infty} \frac{i \sin \frac{x}{c} (m\pi \frac{c}{L})}{\frac{L}{c} \cos \frac{L}{c} (m\pi \frac{c}{L})} e^{-im\pi \frac{c}{L} t} + \sum_{n=1}^{\infty} \frac{-i \sin \frac{x}{c} (n\pi \frac{c}{L})}{\frac{L}{c} \cos \frac{L}{c} (n\pi \frac{c}{L})} e^{in\pi \frac{c}{L} t}$$

Now combining both sums

$$g(x, t) = \sum_{n=1}^{\infty} 2 \frac{c}{L} (-1)^n \sin \frac{n\pi}{L} x \sin \frac{n\pi}{L} ct. \quad (11.2.25)$$

Thus by the convolution theorem, the solution is

$$\begin{aligned} u(x, t) &= \int_0^t \left[ \sum_{n=1}^{\infty} \frac{2c}{L} (-1)^n \sin \frac{n\pi}{L} x \sin \frac{n\pi}{L} c(t - \tau) \right] b(\tau) d\tau \\ &= \sum_{n=1}^{\infty} \frac{2c}{L} (-1)^n \sin \frac{n\pi}{L} x \int_0^t b(\tau) \sin \frac{n\pi}{L} c(t - \tau) d\tau \end{aligned} \quad (11.2.26)$$

or

$$u(x, t) = \sum_{n=1}^{\infty} A_n(t) \sin \frac{n\pi}{L} x, \quad (11.2.27)$$

where

$$A_n(t) = \frac{2c}{L} (-1)^n \int_0^t b(\tau) \sin \frac{n\pi}{L} c(t - \tau) d\tau. \quad (11.2.28)$$

Note that this solution does NOT satisfy the boundary condition at  $x = L$ . Another way to obtain the inverse transform of (11.2.19) is by expanding the quotient using Taylor series of  $\frac{1}{1 - \xi}$ , with  $\xi = e^{-2\frac{L}{c}s}$

$$\begin{aligned} \frac{\sinh s \frac{x}{c}}{\sinh s \frac{L}{c}} &= \frac{e^{\frac{x}{c}s} - e^{-\frac{x}{c}s}}{e^{\frac{L}{c}s} (1 - e^{-2\frac{L}{c}s})} \\ &= \sum_{n=0}^{\infty} \left[ e^{-s \frac{2nL - x + L}{c}} - e^{-s \frac{2nL + x + L}{c}} \right]. \end{aligned} \quad (11.2.29)$$

Since the inverse transform of an exponential function is Dirac delta function, we have

$$g(x, t) = \sum_{n=0}^{\infty} \left[ \delta \left( t - \frac{2nL - x + L}{c} \right) - \delta \left( t - \frac{2nL + x + L}{c} \right) \right]. \quad (11.2.30)$$

The solution is now

$$u(x, t) = \int_0^t b(\tau) \sum_{n=0}^{\infty} \left[ \delta \left( t - \frac{2nL - x + L}{c} - \tau \right) - \delta \left( t - \frac{2nL + x + L}{c} - \tau \right) \right] \quad (11.2.31)$$

or

$$u(x, t) = \sum_{n=0}^{\infty} \left[ b \left( t - \frac{2nL - x + L}{c} \right) - b \left( t - \frac{2nL + x + L}{c} \right) \right]. \quad (11.2.32)$$

This is a different form of the same solution. Now if you check the value at  $x = L$ , we have exactly  $b(t)$  since the second term with  $n$  cancels the first term with  $n + 1$  and we have left with only one term, that is the first term with  $n = 0$ .

## Problems

1. Solve by Laplace transform

$$u_{tt} - c^2 u_{xx} = 0, \quad -\infty < x < \infty,$$

$$u(x, 0) = f(x),$$

$$u_t(x, 0) = 0.$$

2. Solve by Laplace transform

$$u_{tt} - u_{xx} = 0, \quad -\infty < x < \infty,$$

$$u(x, 0) = 0,$$

$$u_t(x, 0) = g(x).$$

3. Solve by Laplace transform

$$u_{tt} - c^2 u_{xx} = 0, \quad 0 < x < L,$$

$$u(x, 0) = 0,$$

$$u_t(x, 0) = 0,$$

$$u_x(0, t) = 0,$$

$$u(L, t) = b(t).$$

4. Solve the previous problem with the boundary conditions

$$u_x(0, t) = 0,$$

$$u_x(L, t) = b(t).$$

5. Solve the heat equation by Laplace transform

$$u_t = u_{xx}, \quad 0 < x < L,$$

$$u(x, 0) = f(x),$$

$$u(0, t) = u(L, t) = 0.$$

## SUMMARY

Definition of Laplace transform

$$\mathcal{L}[f] = F(s) = \int_0^{\infty} f(t)e^{-st} dt,$$

assuming the integral converges (real part of  $s > 0$ ).

The inverse transform is given by

$$f(t) = \mathcal{L}^{-1}[F(s)] = \frac{1}{2\pi i} \int_{\gamma-i\infty}^{\gamma+i\infty} F(s)e^{st} ds,$$

where  $\gamma$  is chosen so that  $f(t)e^{-\gamma t}$  decays sufficiently rapidly as  $t \rightarrow \infty$ .

Properties and examples are in the following table:



Table of Laplace Transforms

$f(x)$	$F(s)$
1	$\frac{1}{s}$
$t^n \quad (n > -1)$	$\frac{n!}{s^{n+1}}$
$t^a$	$\frac{\Gamma(a+1)}{s^{a+1}}$
$e^{at}$	$\frac{1}{s-a}$
$\sin \omega t$	$\frac{\omega}{s^2 + \omega^2}$
$\cos \omega t$	$\frac{s}{s^2 + \omega^2}$
$\sinh \alpha t$	$\frac{\alpha}{s^2 - \alpha^2}$
$\cosh \alpha t$	$\frac{s}{s^2 - \alpha^2}$
$\frac{df}{dt}$	$sF(s) - f(0)$
$\frac{d^2 f}{dt^2}$	$s^2 F(s) - sf(0) - f'(0)$
$\frac{d^n f}{dt^n}$	$s^n F(s) - s^{n-1}f(0) - \dots - f^{(n-1)}(0)$
$tf(t)$	$-\frac{dF}{ds}$
$t^n f(t)$	$(-1)^n \frac{d^n F}{ds^n}$
$\frac{f(t)}{t}$	$\int_s^\infty F(\sigma) d\sigma$
$e^{at} f(t)$	$F(s-a)$
$H(t-b)f(t-b), \quad b > 0$	$e^{-bs} F(s)$
$\int_0^t f(t-\tau)g(\tau)d\tau$	$F(s)G(s)$
$\int_0^t f(\tau)d\tau$	$\frac{F(s)}{s}$
$\delta(t-b), \quad b \geq 0$	$e^{-bs}$

## 12 Finite Differences

### 12.1 Taylor Series

In this chapter we discuss finite difference approximations to partial derivatives. The approximations are based on Taylor series expansions of a function of one or more variables.

Recall that the Taylor series expansion for a function of one variable is given by

$$f(x+h) = f(x) + \frac{h}{1!}f'(x) + \frac{h^2}{2!}f''(x) + \cdots \quad (12.1.1)$$

The remainder is given by

$$f^{(n)}(\xi) \frac{h^n}{n!}, \quad \xi \in (x, x+h). \quad (12.1.2)$$

For a function of more than one independent variable we have the derivatives replaced by partial derivatives. We give here the case of 2 independent variables

$$\begin{aligned} f(x+h, y+k) &= f(x, y) + \frac{h}{1!}f_x(x, y) + \frac{k}{1!}f_y(x, y) + \frac{h^2}{2!}f_{xx}(x, y) \\ &+ \frac{2hk}{2!}f_{xy}(x, y) + \frac{k^2}{2!}f_{yy}(x, y) + \frac{h^3}{3!}f_{xxx}(x, y) + \frac{3h^2k}{3!}f_{xxy}(x, y) \\ &+ \frac{3hk^2}{3!}f_{xyy}(x, y) + \frac{k^3}{3!}f_{yyy}(x, y) + \cdots \end{aligned} \quad (12.1.3)$$

The remainder can be written in the form

$$\frac{1}{n!} \left( h \frac{\partial}{\partial x} + k \frac{\partial}{\partial y} \right)^n f(x + \theta h, y + \theta k), \quad 0 \leq \theta \leq 1. \quad (12.1.4)$$

Here we used a subscript to denote partial differentiation. We will be interested in obtaining approximation about the point  $(x_i, y_j)$  and we use a subscript to denote the function values at the point, i.e.  $f_{ij} = f(x_i, y_j)$ .

The Taylor series expansion for  $f_{i+1}$  about the point  $x_i$  is given by

$$f_{i+1} = f_i + hf'_i + \frac{h^2}{2!}f''_i + \frac{h^3}{3!}f'''_i + \cdots \quad (12.1.5)$$

The Taylor series expansion for  $f_{i+1j+1}$  about the point  $(x_i, y_j)$  is given by

$$f_{i+1j+1} = f_{ij} + (h_x f_x + h_y f_y)_{ij} + \left( \frac{h_x^2}{2} f_{xx} + h_x h_y f_{xy} + \frac{h_y^2}{2} f_{yy} \right)_{ij} + \cdots \quad (12.1.6)$$

Remark: The expansion for  $f_{i+1j}$  about  $(x_i, y_j)$  proceeds as in the case of a function of one variable.

## 12.2 Finite Differences

An infinite number of difference representations can be found for the partial derivatives of  $f(x, y)$ . Let us use the following operators:

$$\text{forward difference operator} \quad \Delta_x f_{ij} = f_{i+1j} - f_{ij} \quad (12.2.1)$$

$$\text{backward difference operator} \quad \nabla_x f_{ij} = f_{ij} - f_{i-1j} \quad (12.2.2)$$

$$\text{centered difference} \quad \bar{\delta}_x f_{ij} = f_{i+1j} - f_{i-1j} \quad (12.2.3)$$

$$\delta_x f_{ij} = f_{i+1/2j} - f_{i-1/2j} \quad (12.2.4)$$

$$\text{averaging operator} \quad \mu_x f_{ij} = (f_{i+1/2j} + f_{i-1/2j})/2 \quad (12.2.5)$$

Note that

$$\bar{\delta}_x = \mu_x \delta_x. \quad (12.2.6)$$

In a similar fashion we can define the corresponding operators in  $y$ .

In the following table we collected some of the common approximations for the first derivative.

Finite Difference	Order (see next chapter)
$\frac{1}{h_x} \Delta_x f_{ij}$	$O(h_x)$
$\frac{1}{h_x} \nabla_x f_{ij}$	$O(h_x)$
$\frac{1}{2h_x} \bar{\delta}_x f_{ij}$	$O(h_x^2)$
$\frac{1}{2h_x} (-3f_{ij} + 4f_{i+1j} - f_{i+2j}) = \frac{1}{h_x} (\Delta_x - \frac{1}{2} \Delta_x^2) f_{ij}$	$O(h_x^2)$
$\frac{1}{2h_x} (3f_{ij} - 4f_{i-1j} + f_{i-2j}) = \frac{1}{h_x} (\nabla_x + \frac{1}{2} \nabla_x^2) f_{ij}$	$O(h_x^2)$
$\frac{1}{h_x} (\mu_x \delta_x - \frac{1}{3!} \mu_x \delta_x^3) f_{ij}$	$O(h_x^3)$
$\frac{1}{2h_x} \frac{\bar{\delta}_x f_{ij}}{1 + \frac{1}{6} \delta_x^2}$	$O(h_x^4)$

Table 1: Order of approximations to  $f_x$

The compact fourth order three point scheme deserves some explanation. Let  $f_x$  be  $v$ , then the method is to be interpreted as

$$(1 + \frac{1}{6} \delta_x^2) v_{ij} = \frac{1}{2h_x} \bar{\delta}_x f_{ij} \quad (12.2.7)$$

or

$$\frac{1}{6} (v_{i+1j} + 4v_{ij} + v_{i-1j}) = \frac{1}{2h_x} \bar{\delta}_x f_{ij}. \quad (12.2.8)$$

This is an **implicit** formula for the derivative  $\frac{\partial f}{\partial x}$  at  $(x_i, y_j)$ . The  $v_{ij}$  can be computed from the  $f_{ij}$  by solving a tridiagonal system of algebraic equations.

The most common second derivative approximations are

$$f_{xx}|_{ij} = \frac{1}{h_x^2}(f_{ij} - 2f_{i+1j} + f_{i+2j}) + O(h_x) \quad (12.2.9)$$

$$f_{xx}|_{ij} = \frac{1}{h_x^2}(f_{ij} - 2f_{i-1j} + f_{i-2j}) + O(h_x) \quad (12.2.10)$$

$$f_{xx}|_{ij} = \frac{1}{h_x^2} \delta_x^2 f_{ij} + O(h_x^2) \quad (12.2.11)$$

$$f_{xx}|_{ij} = \frac{1}{h_x^2} \frac{\delta_x^2 f_{ij}}{1 + \frac{1}{12} \delta_x^2} + O(h_x^4) \quad (12.2.12)$$

Remarks:

1. The order of a scheme is given for a uniform mesh.
2. Tables for difference approximations using more than three points and approximations of mixed derivatives are given in Anderson, Tannehill and Pletcher (1984 , p.45).
3. We will use the notation

$$\hat{\delta}_x^2 = \frac{\delta_x^2}{h_x^2}. \quad (12.2.13)$$

The centered difference operator can be written as a product of the forward and backward operator, i.e.

$$\delta_x^2 f_{ij} = \nabla_x \Delta_x f_{ij}. \quad (12.2.14)$$

This is true since on the right we have

$$\nabla_x (f_{i+1j} - f_{ij}) = f_{i+1j} - f_{ij} - (f_{ij} - f_{i-1j})$$

which agrees with the right hand side of (12.2.14). This idea is important when one wants to approximate  $(p(x)y'(x))'$  at the point  $x_i$  to a second order. In this case one takes the forward difference inside and the backward difference outside (or vice versa)

$$\nabla_x \left( p_i \frac{y_{i+1} - y_i}{\Delta x} \right) \quad (12.2.15)$$

and after expanding again

$$\frac{p_i \frac{y_{i+1} - y_i}{\Delta x} - p_{i-1} \frac{y_i - y_{i-1}}{\Delta x}}{\Delta x} \quad (12.2.16)$$

or

$$\frac{p_i y_{i+1} - (p_i + p_{i-1}) y_i + p_{i-1} y_{i-1}}{(\Delta x)^2}. \quad (12.2.17)$$

Note that if  $p(x) \equiv 1$  then we get the well known centered difference.

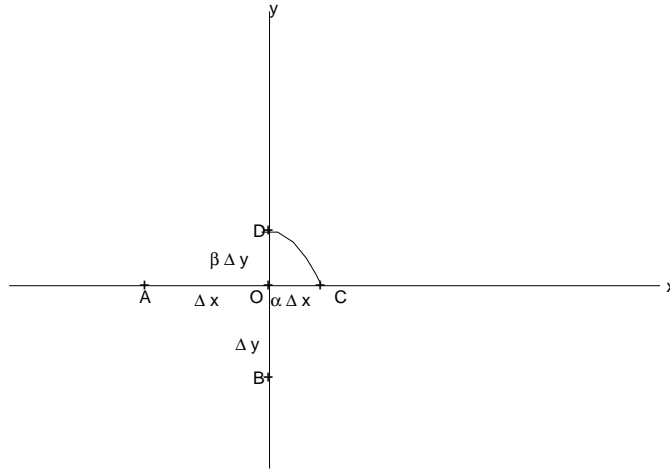

Figure 62: Irregular mesh near curved boundary

### 12.3 Irregular Mesh

Clearly it is more convenient to use a uniform mesh and it is more accurate in some cases. However, in many cases this is not possible due to boundaries which do not coincide with the mesh or due to the need to refine the mesh in part of the domain to maintain the accuracy. In the latter case one is advised to use a coordinate transformation.

In the former case several possible cures are given in, e.g. Anderson et al (1984). The most accurate of these is a development of a finite difference approximation which is valid even when the mesh is nonuniform. It can be shown that

$$u_{xx}\Big|_O \cong \frac{2}{(1+\alpha)h_x} \left( \frac{u_c - u_O}{\alpha h_x} - \frac{u_O - u_A}{h_x} \right) \quad (12.3.1)$$

Similar formula for  $u_{yy}$ . Note that for  $\alpha = 1$  one obtains the centered difference approximation.

We now develop a three point second order approximation for  $\frac{\partial f}{\partial x}$  on a nonuniform mesh.  $\frac{\partial f}{\partial x}$  at point  $O$  can be written as a linear combination of values of  $f$  at  $A$ ,  $O$ , and  $B$ ,

$$\frac{\partial f}{\partial x}\Big|_O = C_1 f(A) + C_2 f(O) + C_3 f(B). \quad (12.3.2)$$

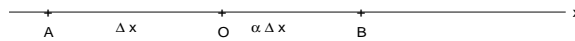

Figure 63: Nonuniform mesh

We use Taylor series to expand  $f(A)$  and  $f(B)$  about the point  $O$ ,

$$f(A) = f(O - \Delta x) = f(O) - \Delta x f'(O) + \frac{\Delta x^2}{2} f''(O) - \frac{\Delta x^3}{6} f'''(O) \pm \dots \quad (12.3.3)$$

$$f(B) = f(O + \alpha\Delta x) = f(O) + \alpha\Delta x f'(O) + \frac{\alpha^2\Delta x^2}{2} f''(O) + \frac{\alpha^3\Delta x^3}{6} f'''(O) + \dots \quad (12.3.4)$$

Thus

$$\begin{aligned} \frac{\partial f}{\partial x}\Big|_O &= (C_1 + C_2 + C_3)f(O) + (\alpha C_3 - C_1)\Delta x \frac{\partial f}{\partial x}\Big|_O + (C_1 + \alpha^2 C_3) \frac{\Delta x^2}{2} \frac{\partial^2 f}{\partial x^2}\Big|_O \\ &+ (\alpha^3 C_3 - C_1) \frac{\Delta x^3}{6} \frac{\partial^3 f}{\partial x^3}\Big|_O + \dots \end{aligned} \quad (12.3.5)$$

This yields the following system of equations

$$C_1 + C_2 + C_3 = 0 \quad (12.3.6)$$

$$-C_1 + \alpha C_3 = \frac{1}{\Delta x} \quad (12.3.7)$$

$$C_1 + \alpha^2 C_3 = 0 \quad (12.3.8)$$

The solution is

$$C_1 = -\frac{\alpha}{(\alpha + 1)\Delta x}, \quad C_2 = \frac{\alpha - 1}{\alpha\Delta x}, \quad C_3 = \frac{1}{\alpha(\alpha + 1)\Delta x} \quad (12.3.9)$$

and thus

$$\frac{\partial f}{\partial x} = \frac{-\alpha^2 f(A) + (\alpha^2 - 1)f(O) + f(B)}{\alpha(\alpha + 1)\Delta x} + \frac{\alpha}{6} \Delta x^2 \frac{\partial^3 f}{\partial x^3}\Big|_O + \dots \quad (12.3.10)$$

Note that if the grid is uniform then  $\alpha = 1$  and this becomes the familiar centered difference.

## 12.4 Thomas Algorithm

This is an algorithm to solve a tridiagonal system of equations

$$\begin{pmatrix} d_1 & a_1 & & \\ b_2 & d_2 & a_2 & \\ & b_3 & d_3 & a_3 \\ \dots & & & \dots \end{pmatrix} \mathbf{u} = \begin{pmatrix} c_1 \\ c_2 \\ c_3 \\ \dots \end{pmatrix} \quad (12.4.1)$$

The first step of Thomas algorithm is to bring the tridiagonal  $M$  by  $M$  matrix to an upper triangular form

$$d_i \leftarrow d_i - \frac{b_i}{d_{i-1}} a_{i-1}, \quad i = 2, 3, \dots, M \quad (12.4.2)$$

$$c_i \leftarrow c_i - \frac{b_i}{d_{i-1}} c_{i-1}, \quad i = 2, 3, \dots, M. \quad (12.4.3)$$

The second step is to backsolve

$$u_M = \frac{c_M}{d_M} \quad (12.4.4)$$

$$u_j = \frac{c_j - a_j u_{j+1}}{d_j}, \quad j = M - 1, \dots, 1. \quad (12.4.5)$$

The following subroutine solves a tridiagonal system of equations:

```

        subroutine tridg(il,iu,rl,d,ru,r)
c
c  solve a tridiagonal system
c  the rhs vector is destroyed and gives the solution
c  the diagonal vector is destroyed
c
integer il,iu
real rl(1),d(1),ru(1),r(1)

C
C  the equations are
C  rl(i)*u(i-1)+d(i)*u(i)+ru(i)*u(i+1)=r(i)
C  il subscript of first equation
C  iu subscript of last equation
C
        ilp=il+1
        do 1 i=ilp,iu
            g=rl(i)/d(i-1)
            d(i)=d(i)-g*ru(i-1)
            r(i)=r(i)-g*r(i-1)
        1 continue
c
c  Back substitution
c
        r(iu)=r(iu)/d(iu)
        do 2 i=ilp,iu
            j=iu-i+1
            r(j)=(r(j)-ru(j)*r(j+1))/d(j)
        2 continue
        return
        end

```

## 12.5 Methods for Approximating PDEs

In this section we discuss several methods to approximate PDEs. These are certainly not all the possibilities.

### 12.5.1 Undetermined coefficients

In this case, we approximate the required partial derivative by a linear combination of function values. The weights are chosen so that the approximation is of the appropriate

order. For example, we can approximate  $u_{xx}$  at  $x_i, y_j$  by taking the three neighboring points,

$$u_{xx}|_{ij} = Au_{i+1j} + Bu_{ij} + Cu_{i-1j} \quad (12.5.1.1)$$

Now expand each of the terms on the right in Taylor series and compare coefficients (all terms are evaluated at  $ij$ )

$$\begin{aligned} u_{xx} = & A \left( u + hu_x + \frac{h^2}{2}u_{xx} + \frac{h^3}{6}u_{xxx} + \frac{h^4}{24}u_{xxxx} + \cdots \right) \\ & + Bu + C \left( u - hu_x + \frac{h^2}{2}u_{xx} - \frac{h^3}{6}u_{xxx} + \frac{h^4}{24}u_{xxxx} \pm \cdots \right) \end{aligned} \quad (12.5.1.2)$$

Upon collecting coefficients, we have

$$A + B + C = 0 \quad (12.5.1.3)$$

$$A - C = 0 \quad (12.5.1.4)$$

$$(A + C)\frac{h^2}{2} = 1 \quad (12.5.1.5)$$

This yields

$$A = C = \frac{1}{h^2} \quad (12.5.1.6)$$

$$B = \frac{-2}{h^2} \quad (12.5.1.7)$$

The error term, is the next nonzero term, which is

$$(A + C)\frac{h^4}{24}u_{xxxx} = \frac{h^2}{12}u_{xxxx}. \quad (12.5.1.8)$$

We call the method second order, because of the  $h^2$  factor in the error term. This is the centered difference approximation given by (12.2.11).

## 12.5.2 Integral Method

The strategy here is to develop an algebraic relationship among the values of the unknowns at neighboring grid points, by integrating the PDE. We demonstrate this on the heat equation integrated around the point  $(x_j, t_n)$ . The solution at this point can be related to neighboring values by integration, e.g.

$$\int_{x_j-\Delta x/2}^{x_j+\Delta x/2} \left( \int_{t_n}^{t_n+\Delta t} u_t dt \right) dx = \alpha \int_{t_n}^{t_n+\Delta t} \left( \int_{x_j-\Delta x/2}^{x_j+\Delta x/2} u_{xx} dx \right) dt. \quad (12.5.2.1)$$

Note the order of integration on both sides.

$$\int_{x_j-\Delta x/2}^{x_j+\Delta x/2} (u(x, t_n + \Delta t) - u(x, t_n)) dx = \alpha \int_{t_n}^{t_n+\Delta t} (u_x(x_j + \Delta x/2, t) - u_x(x_j - \Delta x/2, t)) dt. \quad (12.5.2.2)$$



Now use the mean value theorem, choosing  $x_j$  as the intermediate point on the left and  $t_n + \Delta t$  as the intermediate point on the right,

$$(u(x_j, t_n + \Delta t) - u(x_j, t_n)) \Delta x = \alpha (u_x(x_j + \Delta x/2, t_n + \Delta t) - u_x(x_j - \Delta x/2, t_n + \Delta t)) \Delta t. \quad (12.5.2.3)$$

Now use a centered difference approximation for the  $u_x$  terms and we get the fully implicit scheme, i.e.

$$\frac{u_j^{n+1} - u_j^n}{\Delta t} = \alpha \frac{u_{j+1}^{n+1} - 2u_j^{n+1} + u_{j-1}^{n+1}}{(\Delta x)^2}. \quad (12.5.2.4)$$

## 12.6 Eigenpairs of a Certain Tridiagonal Matrix

Let  $A$  be an  $M$  by  $M$  tridiagonal matrix whose elements on the diagonal are all  $a$ , on the superdiagonal are all  $b$  and on the subdiagonal are all  $c$ ,

$$A = \begin{pmatrix} a & b & & & \\ c & a & b & & \\ & c & a & b & \\ & & & c & a \end{pmatrix} \quad (12.6.1)$$

Let  $\lambda$  be an eigenvalue of  $A$  with an eigenvector  $\mathbf{v}$ , whose components are  $v_i$ . Then the eigenvalue equation

$$A\mathbf{v} = \lambda\mathbf{v} \quad (12.6.2)$$

can be written as follows

$$\begin{aligned} (a - \lambda)v_1 + bv_2 &= 0 \\ cv_1 + (a - \lambda)v_2 + bv_3 &= 0 \\ &\dots \\ cv_{j-1} + (a - \lambda)v_j + bv_{j+1} &= 0 \\ &\dots \\ cv_{M-1} + (a - \lambda)v_M &= 0. \end{aligned}$$

If we let  $v_0 = 0$  and  $v_{M+1} = 0$ , then all the equations can be written as

$$cv_{j-1} + (a - \lambda)v_j + bv_{j+1} = 0, \quad j = 1, 2, \dots, M. \quad (12.6.3)$$

The solution of such second order difference equation is

$$v_j = Bm_1^j + Cm_2^j \quad (12.6.4)$$

where  $m_1$  and  $m_2$  are the solutions of the characteristic equation

$$c + (a - \lambda)m + bm^2 = 0. \quad (12.6.5)$$

It can be shown that the roots are distinct (otherwise  $v_j = (B + Cj)m_1^j$  and the boundary conditions forces  $B = C = 0$ ). Using the boundary conditions, we have

$$B + C = 0 \quad (12.6.6)$$

and

$$Bm_1^{M+1} + Cm_2^{M+1} = 0. \quad (12.6.7)$$

Hence

$$\left(\frac{m_1}{m_2}\right)^{M+1} = 1 = e^{2s\pi i}, \quad s = 1, 2, \dots, M. \quad (12.6.8)$$

Therefore

$$\frac{m_1}{m_2} = e^{2s\pi i/(M+1)}. \quad (12.6.9)$$

From the characteristic equation, we have

$$m_1 m_2 = \frac{c}{b}, \quad (12.6.10)$$

eliminating  $m_2$  leads to

$$m_1 = \sqrt{\frac{c}{b}} e^{s\pi i/(M+1)}. \quad (12.6.11)$$

Similarly for  $m_2$ ,

$$m_2 = \sqrt{\frac{c}{b}} e^{-s\pi i/(M+1)}. \quad (12.6.12)$$

Again from the characteristic equation

$$m_1 + m_2 = (\lambda - a)/b, \quad (12.6.13)$$

giving

$$\lambda = a + b\sqrt{\frac{c}{b}} \left( e^{s\pi i/(M+1)} + e^{-s\pi i/(M+1)} \right). \quad (12.6.14)$$

Hence the  $M$  eigenvalues are

$$\lambda_s = a + 2b\sqrt{\frac{c}{b}} \cos \frac{s\pi}{M+1}, \quad s = 1, 2, \dots, M. \quad (12.6.15)$$

The  $j^{\text{th}}$  component of the eigenvector is

$$v_j = Bm_1^j + Cm_2^j = B \left(\frac{c}{b}\right)^{j/2} \left( e^{js\pi i/(M+1)} - e^{-js\pi i/(M+1)} \right), \quad (12.6.16)$$

that is

$$v_j = 2iB \left(\frac{c}{b}\right)^{j/2} \sin \frac{js\pi}{M+1}. \quad (12.6.17)$$

Use centered difference to approximate the second derivative in  $X'' + \lambda X = 0$  to estimate the eigenvalues assuming  $X(0) = X(1) = 0$ .

## 13 Finite Differences

### 13.1 Introduction

In previous chapters we introduced several methods to solve linear first and second order PDEs and quasilinear first order hyperbolic equations. There are many problems we cannot solve by those analytic methods. Such problems include quasilinear or nonlinear PDEs which are not hyperbolic. We should remark here that the method of characteristics can be applied to nonlinear hyperbolic PDEs. Even some linear PDEs, we cannot solve analytically. For example, Laplace's equation

$$u_{xx} + u_{yy} = 0 \tag{13.1.1}$$

inside a rectangular domain with a hole (see figure 64)

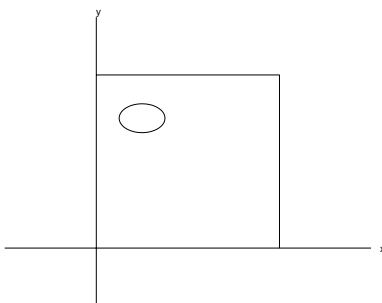

Figure 64: Rectangular domain with a hole

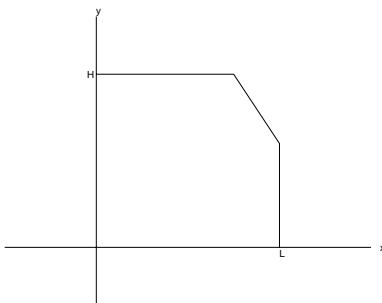

Figure 65: Polygonal domain

or a rectangular domain with one of the corners clipped off.

For such problems, we must use numerical methods. There are several possibilities, but here we only discuss finite difference schemes.

One of the first steps in using finite difference methods is to replace the continuous problem domain by a difference mesh or a grid. Let  $f(x)$  be a function of the single independent variable  $x$  for  $a \leq x \leq b$ . The interval  $[a, b]$  is discretized by considering the nodes  $a = x_0 < x_1 < \dots < x_N < x_{N+1} = b$ , and we denote  $f(x_i)$  by  $f_i$ . The mesh size is  $x_{i+1} - x_i$

and we shall assume for simplicity that the mesh size is a constant

$$h = \frac{b - a}{N + 1} \quad (13.1.2)$$

and

$$x_i = a + ih \quad i = 0, 1, \dots, N + 1 \quad (13.1.3)$$

In the two dimensional case, the function  $f(x, y)$  may be specified at nodal point  $(x_i, y_j)$  by  $f_{ij}$ . The spacing in the  $x$  direction is  $h_x$  and in the  $y$  direction is  $h_y$ .

## 13.2 Difference Representations of PDEs

### I. Truncation error

The difference approximations for the derivatives can be expanded in Taylor series. The truncation error is the difference between the partial derivative and its finite difference representation. For example

$$f_x \Big|_{ij} - \frac{1}{h_x} \Delta_x f_{ij} = f_x \Big|_{ij} - \frac{f_{i+1j} - f_{ij}}{h_x} \quad (13.2.1)$$

$$= -f_{xx} \Big|_{ij} \frac{h_x}{2!} - \dots \quad (13.2.2)$$

We use  $O(h_x)$  which means that the truncation error satisfies  $|T. E.| \leq K|h_x|$  for  $h_x \rightarrow 0$ , sufficiently small, where  $K$  is a positive real constant. Note that  $O(h_x)$  does **not** tell us the exact size of the truncation error. If another approximation has a truncation error of  $O(h_x^2)$ , we might expect that this would be smaller **only** if the mesh is **sufficiently** fine.

We define the order of a method as the lowest power of the mesh size in the truncation error. Thus Table 1 (Chapter 8) gives first through fourth order approximations of the first derivative of  $f$ .

The truncation error for a finite difference approximation of a given PDE is defined as the difference between the two. For example, if we approximate the advection equation

$$\frac{\partial F}{\partial t} + c \frac{\partial F}{\partial x} = 0, \quad c > 0 \quad (13.2.3)$$

by centered differences

$$\frac{F_{ij+1} - F_{ij-1}}{2\Delta t} + c \frac{F_{i+1j} - F_{i-1j}}{2\Delta x} = 0 \quad (13.2.4)$$

then the truncation error is

$$\begin{aligned} T. E. &= \left( \frac{\partial F}{\partial t} + c \frac{\partial F}{\partial x} \right)_{ij} - \frac{F_{ij+1} - F_{ij-1}}{2\Delta t} - c \frac{F_{i+1j} - F_{i-1j}}{2\Delta x} \\ &= -\frac{1}{6} \Delta t^2 \frac{\partial^3 F}{\partial t^3} - c \frac{1}{6} \Delta x^2 \frac{\partial^3 F}{\partial x^3} - \text{higher powers of } \Delta t \text{ and } \Delta x. \end{aligned} \quad (13.2.5)$$

We will write

$$T.E. = O(\Delta t^2, \Delta x^2) \quad (13.2.6)$$

In the case of the simple explicit method

$$\frac{u_j^{n+1} - u_j^n}{\Delta t} = k \frac{u_{j+1}^n - 2u_j^n + u_{j-1}^n}{(\Delta x)^2} \quad (13.2.7)$$

for the heat equation

$$u_t = ku_{xx} \quad (13.2.8)$$

one can show that the truncation error is

$$T.E. = O(\Delta t, \Delta x^2) \quad (13.2.9)$$

since the terms in the finite difference approximation (13.2.7) can be expanded in Taylor series to get

$$u_t - ku_{xx} + u_{tt} \frac{\Delta t}{2} - ku_{xxxx} \frac{(\Delta x)^2}{12} + \dots$$

All the terms are evaluated at  $x_j, t_n$ . Note that the first two terms are the PDE and all other terms are the truncation error. Of those, the ones with the lowest order in  $\Delta t$  and  $\Delta x$  are called the leading terms of the truncation error.

Remark: See lab3 (3243taylor.ms) for the use of Maple to get the truncation error.

## II. Consistency

A difference equation is said to be consistent or compatible with the partial differential equation when it approaches the latter as the mesh sizes approaches zero. This is equivalent to

$$T.E. \rightarrow 0 \quad \text{as mesh sizes} \rightarrow 0.$$

This seems obviously true. One can mention an example of an inconsistent method (see e.g. Smith (1985)). The DuFort-Frankel scheme for the heat equation (13.2.8) is given by

$$\frac{u_j^{n+1} - u_j^{n-1}}{2\Delta t} = k \frac{u_{j+1}^n - u_j^{n+1} - u_j^{n-1} + u_{j-1}^n}{\Delta x^2}. \quad (13.2.10)$$

The truncation error is

$$\frac{k}{12} \frac{\partial^4 u}{\partial x^4} \Big|_j \Delta x^2 - \frac{\partial^2 u}{\partial t^2} \Big|_j \left( \frac{\Delta t}{\Delta x} \right)^2 - \frac{1}{6} \frac{\partial^3 u}{\partial t^3} \Big|_j (\Delta t)^2 + \dots \quad (13.2.11)$$

If  $\Delta t, \Delta x$  approach zero at the same rate such that  $\frac{\Delta t}{\Delta x} = \text{constant} = \beta$ , then the method is inconsistent (we get the PDE

$$u_t + \beta^2 u_{tt} = ku_{xx}$$

instead of (13.2.8).)

### III. Stability

A numerical scheme is called stable if errors from any source (e.g. truncation, round-off, errors in measurements) are not permitted to grow as the calculation proceeds. One can show that DuFort-Frankel scheme is unconditionally stable. Richtmeyer and Morton give a less stringent definition of stability. A scheme is stable if its solution remains a uniformly bounded function of the initial state for all sufficiently small  $\Delta t$ .

The problem of stability is very important in numerical analysis. There are two methods for checking the stability of linear difference equations. The first one is referred to as Fourier or von Neumann assumes the boundary conditions are periodic. The second one is called the matrix method and takes care of contributions to the error from the boundary.

#### von Neumann analysis

Suppose we solve the heat equation (13.2.8) by the simple explicit method (13.2.7). If a term (a single term of Fourier and thus the linearity assumption)

$$\epsilon_j^n = e^{at_n} e^{ik_m x_j} \quad (13.2.12)$$

is substituted into the difference equation, one obtains after dividing through by  $e^{at_n} e^{ik_m x_j}$

$$e^{a\Delta t} = 1 + 2r(\cos \beta - 1) = 1 - 4r \sin^2 \frac{\beta}{2} \quad (13.2.13)$$

where

$$r = k \frac{\Delta t}{(\Delta x)^2} \quad (13.2.14)$$

$$\beta = k_m \Delta x, \quad k_m = \frac{2\pi m}{2L}, m = 0, \dots, M, \quad (13.2.15)$$

where  $M$  is the number of  $\Delta x$  units contained in  $L$ . The stability requirement is

$$|e^{a\Delta t}| \leq 1 \quad (13.2.16)$$

implies

$$r \leq \frac{1}{2}. \quad (13.2.17)$$

The term  $|e^{a\Delta t}|$  also denoted  $G$  is called the amplification factor. The simple explicit method is called conditionally stable, since we had to satisfy the condition (13.2.17) for stability.

One can show that the simple implicit method for the same equation is unconditionally stable. Of course the price in this case is the need to solve a system of equations at every time step. The following method is an example of an unconditionally unstable method:

$$\frac{u_j^{n+1} - u_j^{n-1}}{2\Delta t} = k \frac{u_{j+1}^n - 2u_j^n + u_{j-1}^n}{\Delta x^2}. \quad (13.2.18)$$

This method is second order in time and space but useless. The DuFort Frankel is a way to stabilize this second order in time scheme.

### IV. Convergence

A scheme is called convergent if the solution to the finite difference equation approaches the exact solution to the PDE with the same initial and boundary conditions as the mesh sizes approach zero. Lax has proved that under appropriate conditions a consistent scheme is convergent if and only if it is stable.

Lax equivalence theorem

Given a properly posed linear initial value problem and a finite difference approximation to it that satisfies the consistency condition, stability (a-la Richtmeyer and Morton (1967)) is the necessary and sufficient condition for convergence.

## V. Modified Equation

The importance of the modified equation is in helping to analyze the numerical effects of the discretization. The way to obtain the modified equation is by starting with the truncation error and replacing the time derivatives by spatial differentiation using the equation obtained from truncation error. It is easier to discuss the details on an example. For the heat equation

$$u_t - ku_{xx} = 0$$

we have the following explicit method

$$\frac{u_j^{n+1} - u_j^n}{\Delta t} - k \frac{u_{j+1}^n - 2u_j^n + u_{j-1}^n}{(\Delta x)^2} = 0. \quad (13.2.19)$$

The truncation error is (all terms are given at  $t_n, x_j$ )

$$u_t - ku_{xx} = -\frac{\Delta t}{2}u_{tt} + \frac{(\Delta x)^2}{12}ku_{xxxx} \pm \dots \quad (13.2.20)$$

This is the equation we have to use to eliminate the time derivatives. After several differentiations and substitutions, we get

$$u_t - ku_{xx} = \left[ -\frac{1}{2}k^2\Delta t + k\frac{(\Delta x)^2}{12} \right] u_{xxxx} + \left[ \frac{1}{3}k^3(\Delta t)^2 - \frac{1}{12}k^2\Delta t(\Delta x)^2 + \frac{1}{360}k(\Delta x)^4 \right] u_{xxxxx} + \dots$$

It is easier to organize the work in a tabular form. We will show that later when discussing first order hyperbolic.

Note that for  $r = \frac{1}{6}$ , the truncation error is  $O(\Delta t^2, \Delta x^4)$ . The problem is that one has to do 3 times the number of steps required by the limit of stability,  $r = \frac{1}{2}$ .

Note also there are NO odd derivative terms, that is no dispersive error (dispersion means that phase relation between various waves are distorted, or the same as saying that the amplification factor has no imaginary part.)

Note that the exact amplification can be obtained as the quotient

$$G_{exact} = \frac{u(t + \Delta t, x)}{u(t, x)} = e^{-r\beta^2} \quad (13.2.21)$$

See figure 66 for a plot of the amplification factor  $G$  versus  $\beta$ .

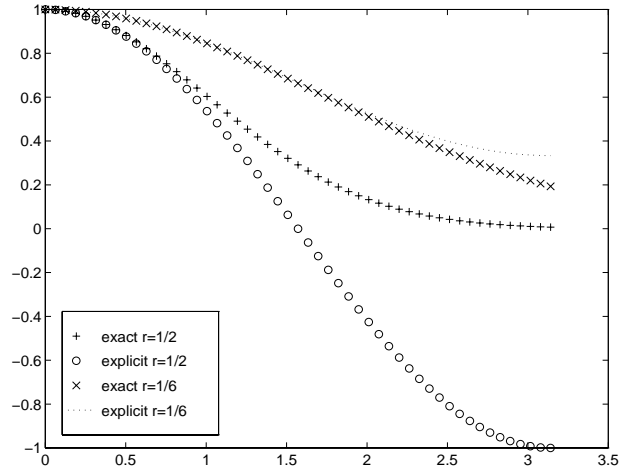

Figure 66: Amplification factor for simple explicit method

### 13.3 Heat Equation in One Dimension

In this section we apply finite differences to obtain an approximate solution of the heat equation in one dimension,

$$u_t = ku_{xx}, \quad 0 < x < 1, \quad t > 0, \quad (13.3.1)$$

subject to the initial and boundary conditions

$$u(x, 0) = f(x), \quad (13.3.2)$$

$$u(0, t) = u(1, t) = 0. \quad (13.3.3)$$

Using forward approximation for  $u_t$  and centered differences for  $u_{xx}$  we have

$$u_j^{n+1} - u_j^n = k \frac{\Delta t}{(\Delta x)^2} (u_{j-1}^n - 2u_j^n + u_{j+1}^n), \quad j = 1, 2, \dots, N-1, \quad n = 0, 1, \dots \quad (13.3.4)$$

where  $u_j^n$  is the approximation to  $u(x_j, t_n)$ , the nodes  $x_j, t_n$  are given by

$$x_j = j\Delta x, \quad j = 0, 1, \dots, N \quad (13.3.5)$$

$$t_n = n\Delta t, \quad n = 0, 1, \dots \quad (13.3.6)$$

and the mesh spacing

$$\Delta x = \frac{1}{N}, \quad (13.3.7)$$

see figure 67.

The solution at the points marked by \* is given by the initial condition

$$u_j^0 = u(x_j, 0) = f(x_j), \quad j = 0, 1, \dots, N \quad (13.3.8)$$



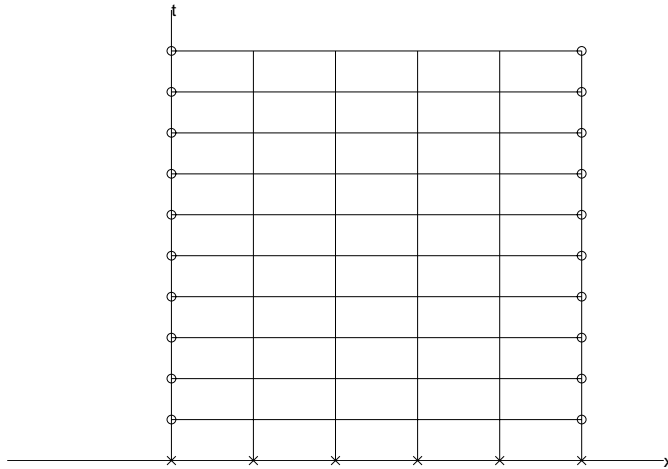

Figure 67: Uniform mesh for the heat equation

and the solution at the points marked by  $\oplus$  is given by the boundary conditions

$$u(0, t_n) = u(x_N, t_n) = 0,$$

or

$$u_0^n = u_N^n = 0. \quad (13.3.9)$$

The solution at other grid points can be obtained from (13.3.4)

$$u_j^{n+1} = ru_{j-1}^n + (1 - 2r)u_j^n + ru_{j+1}^n, \quad (13.3.10)$$

where  $r$  is given by (13.2.14). The implementation of (13.3.10) is easy. The value at any grid point requires the knowledge of the solution at the three points below. We describe this by the following computational molecule (figure 68).

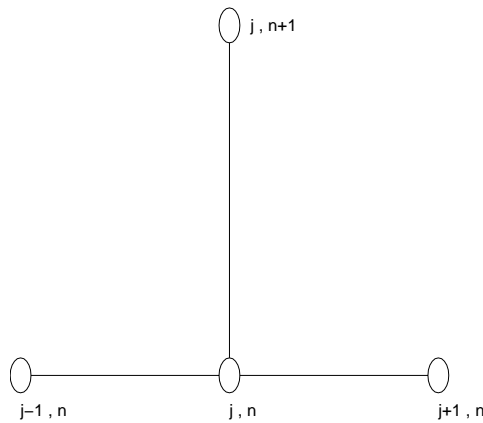

Figure 68: Computational molecule for explicit solver

We can compute the solution at the leftmost grid point on the horizontal line representing  $t_1$  and continue to the right. Then we can advance to the next horizontal line representing  $t_2$  and so on. Such a scheme is called explicit.

The time step  $\Delta t$  must be chosen in such a way that stability is satisfied, that is

$$\Delta t \leq \frac{k}{2} (\Delta x)^2. \quad (13.3.11)$$

We will see in the next sections how to overcome the stability restriction and how to obtain higher order method.

### 13.3.1 Implicit method

One of the ways to overcome this restriction is to use an implicit method

$$u_j^{n+1} - u_j^n = k \frac{\Delta t}{(\Delta x)^2} (u_{j-1}^{n+1} - 2u_j^{n+1} + u_{j+1}^{n+1}), \quad j = 1, 2, \dots, N-1, \quad n = 0, 1, \dots \quad (13.3.1.1)$$

The computational molecule is given in figure 69. The method is unconditionally stable, since the amplification factor is given by

$$G = \frac{1}{1 + 2r(1 - \cos \beta)} \quad (13.3.1.2)$$

which is  $\leq 1$  for any  $r$ . The price for this is having to solve a tridiagonal system for each time step. The method is still first order in time. See figure 70 for a plot of  $G$  for explicit and implicit methods.

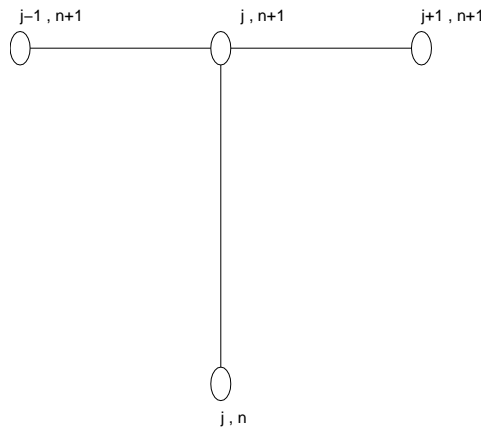

Figure 69: Computational molecule for implicit solver

### 13.3.2 DuFort Frankel method

If one tries to use centered difference in time and space, one gets an unconditionally unstable method as we mentioned earlier. Thus to get a stable method of second order in time, DuFort Frankel came up with:

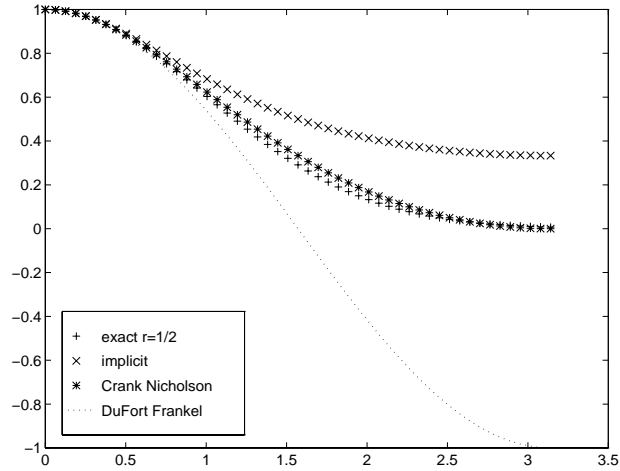

Figure 70: Amplification factor for several methods

$$\frac{u_j^{n+1} - u_j^{n-1}}{2\Delta t} = k \frac{u_{j+1}^n - u_j^{n+1} - u_j^{n-1} + u_{j-1}^n}{\Delta x^2} \quad (13.3.2.1)$$

We have seen earlier that the method is explicit with a truncation error

$$T.E. = O\left(\Delta t^2, \Delta x^2, \left(\frac{\Delta t}{\Delta x}\right)^2\right). \quad (13.3.2.2)$$

The modified equation is

$$\begin{aligned} u_t - ku_{xx} &= \left(\frac{1}{12}k\Delta x^2 - k^3\frac{\Delta t^2}{\Delta x^2}\right)u_{xxxx} \\ &+ \left[\frac{1}{360}k\Delta x^4 - \frac{1}{3}k^3\Delta t^2 + 2k^5\frac{\Delta t^4}{\Delta x^4}\right]u_{xxxxx} + \dots \end{aligned} \quad (13.3.2.3)$$

The amplification factor is given by

$$G = \frac{2r \cos \beta \pm \sqrt{1 - 4r^2 \sin^2 \beta}}{1 + 2r} \quad (13.3.2.4)$$

and thus the method is unconditionally stable.

The only drawback is the requirement of an additional starting line.

### 13.3.3 Crank-Nicholson method

Another way to overcome this stability restriction, we can use Crank-Nicholson implicit scheme

$$-ru_{j-1}^{n+1} + 2(1+r)u_j^{n+1} - ru_{j+1}^{n+1} = ru_{j-1}^n + 2(1-r)u_j^n + ru_{j+1}^n. \quad (13.3.3.1)$$

This is obtained by centered differencing in time about the point  $x_j, t_{n+1/2}$ . On the right we average the centered differences in space at time  $t_n$  and  $t_{n+1}$ . The computational molecule is now given in the next figure (71).

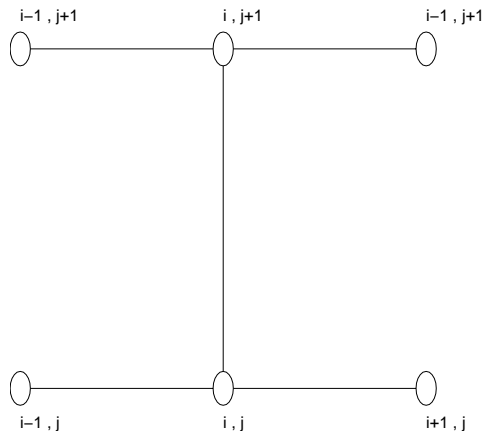

Figure 71: Computational molecule for Crank Nicholson solver

The method is unconditionally stable, since the denominator is always larger than numerator in

$$G = \frac{1 - r(1 - \cos \beta)}{1 + r(1 - \cos \beta)}. \quad (13.3.3.2)$$

It is second order in time (centered difference about  $x_j, t_{n+1/2}$ ) and space. The modified equation is

$$u_t - ku_{xx} = \frac{k\Delta x^2}{12}u_{xxxx} + \left[ \frac{1}{12}k^3\Delta t^2 + \frac{1}{360}k\Delta x^4 \right] u_{xxxxxx} + \dots \quad (13.3.3.3)$$

The disadvantage of the implicit scheme (or the price we pay to overcome the stability barrier) is that we require a solution of system of equations at each time step. The number of equations is  $N - 1$ .

We include in the appendix a Fortran code for the solution of (13.3.1)-(13.3.3) using the explicit and implicit solvers. We must say that one can construct many other explicit or implicit solvers. We allow for the more general boundary conditions

$$A_L u_x + B_L u = C_L, \quad \text{on the left boundary} \quad (13.3.3.4)$$

$$A_R u_x + B_R u = C_R, \quad \text{on the right boundary.} \quad (13.3.3.5)$$

Remark: For a more general boundary conditions, see for example Smith (1985), we need to finite difference the derivative in the boundary conditions.

### 13.3.4 Theta ( $\theta$ ) method

All the method discussed above (except DuFort Frankel) can be written as

$$\frac{u_j^{n+1} - u_j^n}{\Delta t} = k \frac{\theta(u_{j+1}^{n+1} - 2u_j^{n+1} + u_{j-1}^{n+1}) + (1 - \theta)(u_{j+1}^n - 2u_j^n + u_{j-1}^n)}{\Delta x^2} \quad (13.3.4.1)$$

For  $\theta = 0$  we get the explicit method (13.3.10), for  $\theta = 1$ , we get the implicit method (9.3.1.1) and for  $\theta = \frac{1}{2}$  we have Crank Nicholson (9.3.3.1).

The truncation error is

$$O(\Delta t, \Delta x^2)$$

except for Crank Nicholson as we have seen earlier (see also the modified equation below.) If one chooses  $\theta = \frac{1}{2} - \frac{\Delta x^2}{12k\Delta t}$  (the coefficient of  $u_{xxxx}$  vanishes), then we get  $O(\Delta t^2, \Delta x^4)$ , and if we choose the same  $\theta$  with  $\frac{\Delta x^2}{k\Delta t} = \sqrt{20}$  (the coefficient of  $u_{xxxxxx}$  vanishes), then  $O(\Delta t^2, \Delta x^6)$ .

The method is conditionally stable for  $0 \leq \theta < \frac{1}{2}$  with the condition

$$r \leq \frac{1}{2 - 4\theta} \quad (13.3.4.2)$$

and unconditionally stable for  $\frac{1}{2} \leq \theta \leq 1$ .

The modified equation is

$$\begin{aligned} u_t - ku_{xx} &= \left( \frac{1}{12}k\Delta x^2 + \left(\theta - \frac{1}{2}\right)k^2\Delta t \right) u_{xxxx} \\ &+ \left[ \left(\theta^2 - \theta + \frac{1}{3}\right)k^3\Delta t^2 + \frac{1}{6}\left(\theta - \frac{1}{2}\right)k^2\Delta t\Delta x^2 + \frac{1}{360}k\Delta x^4 \right] u_{xxxxxx} + \dots \end{aligned} \quad (13.3.4.3)$$

### 13.3.5 An example

We have used the explicit solver program to approximate the solution of

$$u_t = u_{xx}, \quad 0 < x < 1, \quad t > 0 \quad (13.3.5.1)$$

$$u(x, 0) = \begin{cases} 2x & 0 < x < \frac{1}{2} \\ 2(1-x) & \frac{1}{2} < x < 1 \end{cases} \quad (13.3.5.2)$$

$$u(0, t) = u(1, t) = 0, \quad (13.3.5.3)$$

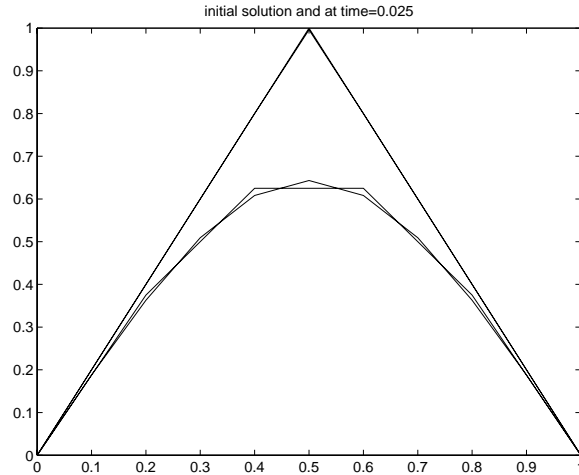

Figure 72: Numerical and analytic solution with  $r = .5$  at  $t = .025$

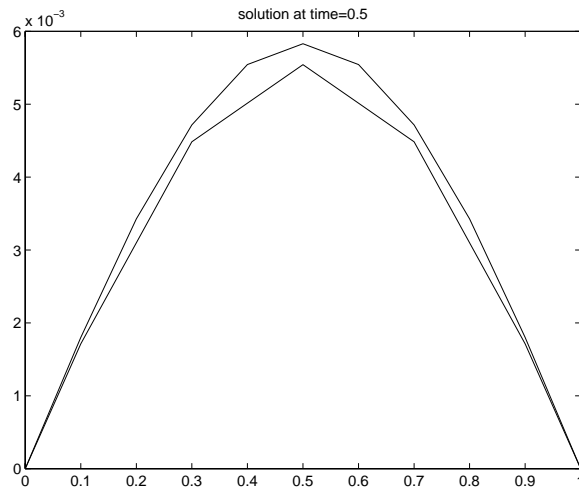

Figure 73: Numerical and analytic solution with  $r = .5$  at  $t = .5$

using a variety of values of  $r$ . The results are summarized in the following figures.

The analytic solution (using separation of variables) is given by

$$u(x, t) = \sum_{n=0}^{\infty} a_n e^{-(n\pi)^2 t} \sin n\pi x, \quad (13.3.5.4)$$

where  $a_n$  are the Fourier coefficients for the expansion of the initial condition (13.3.5.2),

$$a_n = \frac{8}{(n\pi)^2} \sin \frac{n\pi}{2}, \quad n = 1, 2, \dots \quad (13.3.5.5)$$

The analytic solution (13.3.5.4) and the numerical solution (using  $\Delta x = .1$ ,  $r = .5$ ) at times  $t = .025$  and  $t = .5$  are given in the two figures 72, 73. It is clear that the error increases in time but still smaller than  $.5 \times 10^{-4}$ .

On the other hand, if  $r = .51$ , we see oscillations at time  $t = .0255$  (figure 74) which become very large at time  $t = .255$  (figure 75) and the temperature becomes negative at  $t = .459$  (figure 76).

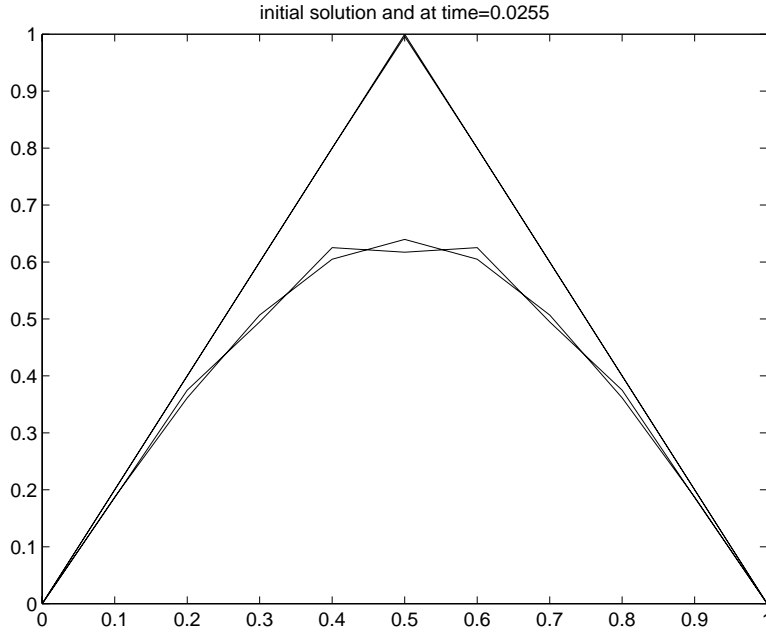

Figure 74: Numerical and analytic solution with  $r = .51$  at  $t = .0255$

Clearly the solution does not converge when  $r > .5$ .

The implicit solver program was used to approximate the solution of (13.3.5.1) subject to

$$u(x, 0) = 100 - 10|x - 10| \tag{13.3.5.6}$$

and

$$u_x(0, t) = .2(u(0, t) - 15), \tag{13.3.5.7}$$

$$u(1, t) = 100. \tag{13.3.5.8}$$

Notice that the boundary and initial conditions do not agree at the right boundary. Because of the type of boundary condition at  $x = 0$ , we cannot give the eigenvalues explicitly. Notice that the problem is also having inhomogeneous boundary conditions. To be able to compare the implicit and explicit solvers, we have used Crank-Nicholson to solve (13.3.5.1)-(13.3.5.3). We plot the analytic and numerical solution with  $r = 1$  at time  $t = .5$  to show that the method is stable (compare the following figure 77 to the previous one with  $r = .51$ ).

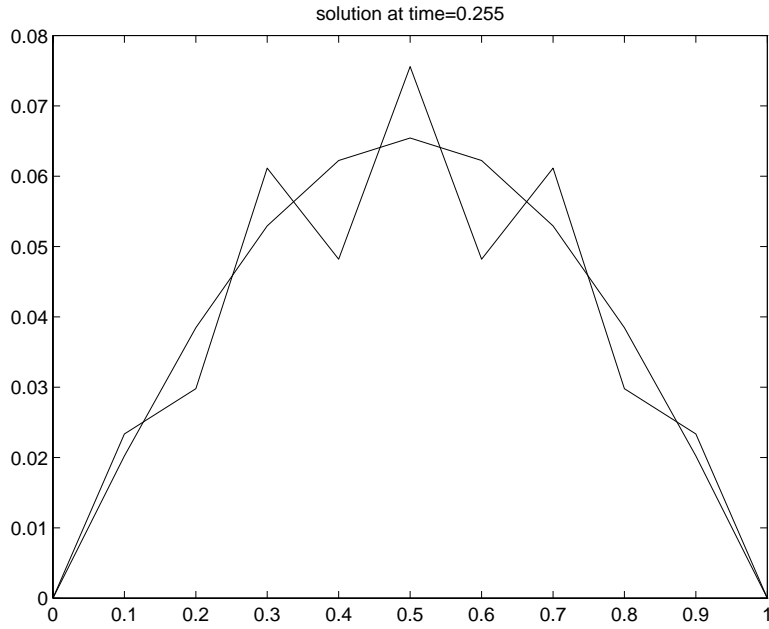

Figure 75: Numerical and analytic solution with  $r = .51$  at  $t = .255$

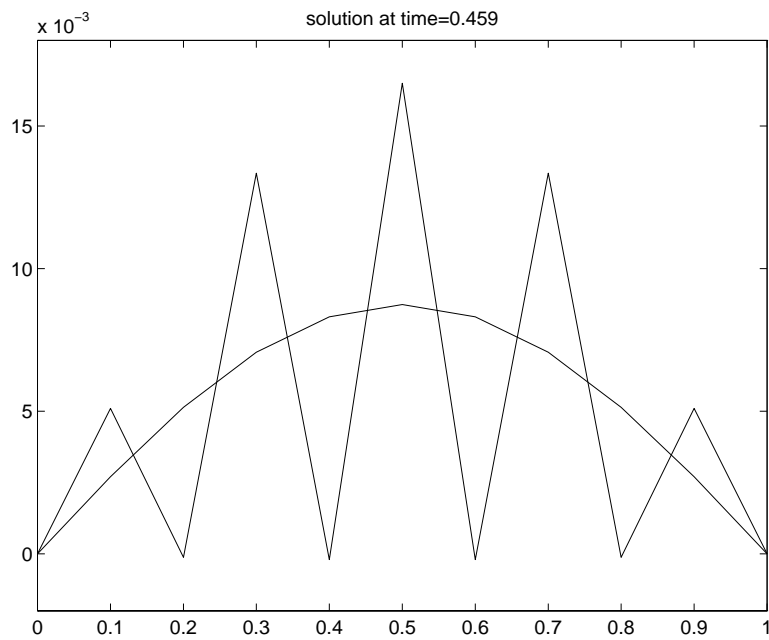

Figure 76: Numerical and analytic solution with  $r = .51$  at  $t = .459$



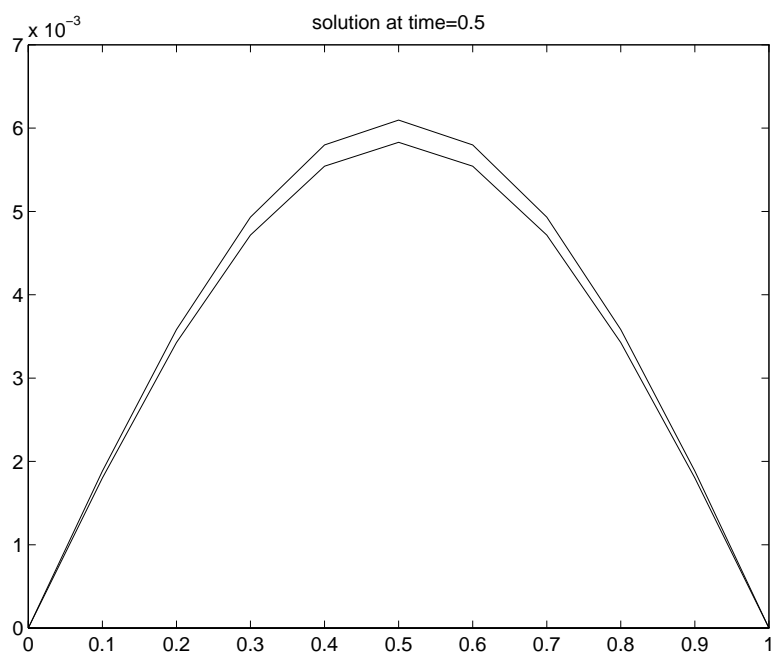

Figure 77: Numerical (implicit) and analytic solution with  $r = 1$ . at  $t = .5$

## 13.4 Two Dimensional Heat Equation

In this section, we generalize the solution of the heat equation obtained in section 9.3 to two dimensions. The problem of heat conduction in a rectangular membrane is described by

$$u_t = \alpha(u_{xx} + u_{yy}), \quad 0 < x < L, \quad 0 < y < H, \quad t > 0 \quad (13.4.1)$$

subject to

$$u(x, y, t) = g(x, y, t), \quad \text{on the boundary} \quad (13.4.2)$$

$$u(x, y, 0) = f(x, y), \quad 0 < x < L, \quad 0 < y < H. \quad (13.4.3)$$

### 13.4.1 Explicit

To obtain an explicit scheme, we use forward difference in time and centered differences in space. Thus

$$\frac{u_{ij}^{n+1} - u_{ij}^n}{\Delta t} = \alpha \left( \frac{u_{i-1j}^n - 2u_{ij}^n + u_{i+1j}^n}{(\Delta x)^2} + \frac{u_{ij-1}^n - 2u_{ij}^n + u_{ij+1}^n}{(\Delta y)^2} \right) \quad (13.4.1.1)$$

or

$$u_{ij}^{n+1} = r_x u_{i-1j}^n + (1 - 2r_x - 2r_y) u_{ij}^n + r_x u_{i+1j}^n + r_y u_{ij-1}^n + r_y u_{ij+1}^n, \quad (13.4.1.2)$$

where  $u_{ij}^n$  is the approximation to  $u(x_i, y_j, t_n)$  and

$$r_x = \alpha \frac{\Delta t}{(\Delta x)^2}, \quad (13.4.1.3)$$

$$r_y = \alpha \frac{\Delta t}{(\Delta y)^2}. \quad (13.4.1.4)$$

The stability condition imposes a limit on the time step

$$\alpha \Delta t \left( \frac{1}{\Delta x^2} + \frac{1}{\Delta y^2} \right) \leq \frac{1}{2} \quad (13.4.1.5)$$

For the case  $\Delta x = \Delta y = d$ , we have

$$\Delta t \leq \frac{1}{4\alpha} d^2 \quad (13.4.1.6)$$

which is more restrictive than in the one dimensional case. The solution at any point  $(x_i, y_j, t_n)$  requires the knowledge of the solution at all 5 points at the previous time step (see next figure 78).

Since the solution is known at  $t = 0$ , we can compute the solution at  $t = \Delta t$  one point at a time.

To overcome the stability restriction, we can use Crank-Nicholson implicit scheme. The matrix in this case will be banded of higher dimension and wider band. There are other implicit schemes requiring solution of smaller size systems, such as alternating direction. In the next section we will discuss Crank Nicholson and ADI (Alternating Direction Implicit).

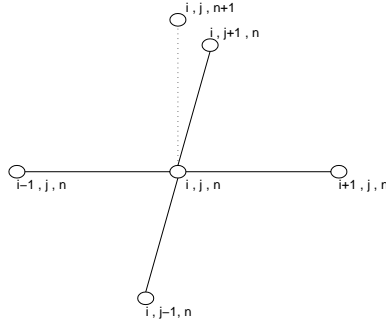

Figure 78: Computational molecule for the explicit solver for 2D heat equation

### 13.4.2 Crank Nicholson

One way to overcome this stability restriction is to use Crank-Nicholson implicit scheme

$$\frac{u_{ij}^{n+1} - u_{ij}^n}{\Delta t} = \alpha \frac{\delta_x^2 u_{ij}^n + \delta_x^2 u_{ij}^{n+1}}{(2\Delta x)^2} + \alpha \frac{\delta_y^2 u_{ij}^n + \delta_y^2 u_{ij}^{n+1}}{(2\Delta y)^2} \quad (13.4.2.1)$$

The method is unconditionally stable. It is second order in time (centered difference about  $x_i, y_j, t_{n+1/2}$ ) and space.

It is important to order the two subscript in one dimensional index in the right direction (if the number of grid point in  $x$  and  $y$  is not identical), otherwise the bandwidth will increase.

Note that the coefficients of the banded matrix are independent of time (if  $\alpha$  is not a function of  $t$ ), and thus one have to factor the matrix only once.

### 13.4.3 Alternating Direction Implicit

The idea here is to alternate direction and thus solve two one-dimensional problem at each time step. The first step to keep  $y$  fixed

$$\frac{u_{ij}^{n+1/2} - u_{ij}^n}{\Delta t/2} = \alpha \left( \hat{\delta}_x^2 u_{ij}^{n+1/2} + \hat{\delta}_y^2 u_{ij}^n \right) \quad (13.4.3.1)$$

In the second step we keep  $x$  fixed

$$\frac{u_{ij}^{n+1} - u_{ij}^{n+1/2}}{\Delta t/2} = \alpha \left( \hat{\delta}_x^2 u_{ij}^{n+1/2} + \hat{\delta}_y^2 u_{ij}^{n+1} \right) \quad (13.4.3.2)$$

So we have a tridiagonal system at every step. We have to order the unknown differently at every step.

The method is second order in time and space and it is unconditionally stable, since the denominator is always larger than numerator in

$$G = \frac{1 - r_x(1 - \cos \beta_x)}{1 + r_x(1 - \cos \beta_x)} \frac{1 - r_y(1 - \cos \beta_y)}{1 + r_y(1 - \cos \beta_y)}. \quad (13.4.3.3)$$

The obvious extension to three dimensions is only first order in time and conditionally stable. Douglas & Gunn developed a general scheme called approximate factorization to ensure second order and unconditional stability.

Let

$$\Delta u_{ij} = u_{ij}^{n+1} - u_{ij}^n \quad (13.4.3.4)$$

Substitute this into the two dimensional Crank Nicholson

$$\Delta u_{ij} = \frac{\alpha \Delta t}{2} \left\{ \hat{\delta}_x^2 \Delta u_{ij} + \hat{\delta}_y^2 \Delta u_{ij} + 2\hat{\delta}_x^2 u_{ij}^n + 2\hat{\delta}_y^2 u_{ij}^n \right\} \quad (13.4.3.5)$$

Now rearrange,

$$\left( 1 - \frac{r_x}{2} \delta_x^2 - \frac{r_y}{2} \delta_y^2 \right) \Delta u_{ij} = (r_x \delta_x^2 + r_y \delta_y^2) u_{ij}^n \quad (13.4.3.6)$$

The left hand side operator can be factored

$$1 - \frac{r_x}{2} \delta_x^2 - \frac{r_y}{2} \delta_y^2 = \left( 1 - \frac{r_x}{2} \delta_x^2 \right) \left( 1 - \frac{r_y}{2} \delta_y^2 \right) - \frac{r_x r_y}{4} \delta_x^2 \delta_y^2 \quad (13.4.3.7)$$

The last term can be neglected because it is of higher order. Thus the method for two dimensions becomes

$$\left( 1 - \frac{r_x}{2} \delta_x^2 \right) \Delta u_{ij}^* = (r_x \delta_x^2 + r_y \delta_y^2) u_{ij}^n \quad (13.4.3.8)$$

$$\left( 1 - \frac{r_y}{2} \delta_y^2 \right) \Delta u_{ij} = \Delta u_{ij}^* \quad (13.4.3.9)$$

$$u_{ij}^{n+1} = u_{ij}^n + \Delta u_{ij} \quad (13.4.3.10)$$

## 13.5 Laplace's Equation

In this section, we discuss the approximation of the steady state solution inside a rectangle

$$u_{xx} + u_{yy} = 0, \quad 0 < x < L, \quad 0 < y < H, \quad (13.5.1)$$

subject to Dirichlet boundary conditions

$$u(x, y) = f(x, y), \quad \text{on the boundary.} \quad (13.5.2)$$

We impose a uniform grid on the rectangle with mesh spacing  $\Delta x$ ,  $\Delta y$  in the  $x$ ,  $y$  directions, respectively. The finite difference approximation is given by

$$\frac{u_{i-1j} - 2u_{ij} + u_{i+1j}}{(\Delta x)^2} + \frac{u_{ij-1} - 2u_{ij} + u_{ij+1}}{(\Delta y)^2} = 0, \quad (13.5.3)$$

or

$$\left[ \frac{2}{(\Delta x)^2} + \frac{2}{(\Delta y)^2} \right] u_{ij} = \frac{u_{i-1j} + u_{i+1j}}{(\Delta x)^2} + \frac{u_{ij-1} + u_{ij+1}}{(\Delta y)^2}. \quad (13.5.4)$$

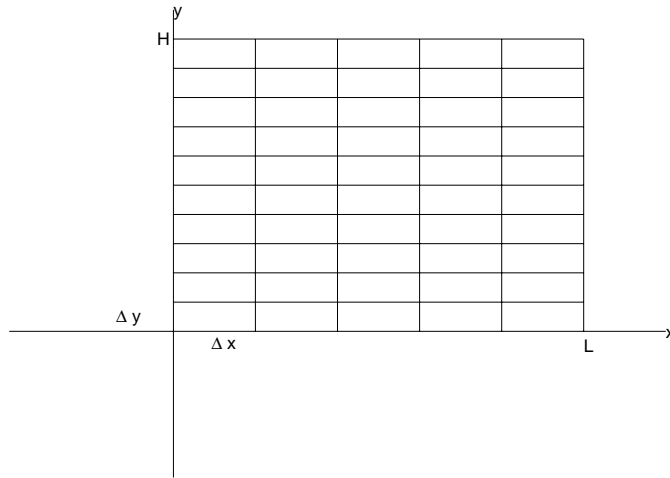

Figure 79: Uniform grid on a rectangle

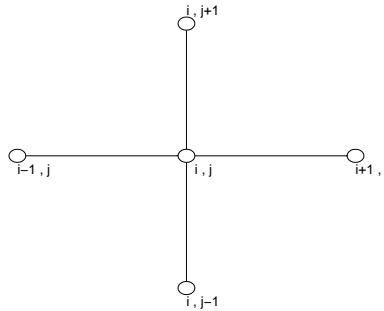

Figure 80: Computational molecule for Laplace's equation

For  $\Delta x = \Delta y$  we have

$$4u_{ij} = u_{i-1,j} + u_{i+1,j} + u_{i,j-1} + u_{i,j+1}. \quad (13.5.5)$$

The computational molecule is given in the next figure (80). This scheme is called five point star because of the shape of the molecule.

The truncation error is

$$T.E. = O(\Delta x^2, \Delta y^2) \quad (13.5.6)$$

and the modified equations is

$$u_{xx} + u_{yy} = -\frac{1}{12} (\Delta x^2 u_{xxxx} + \Delta y^2 u_{yyyy}) + \dots \quad (13.5.7)$$

Remark: To obtain a higher order method, one can use the nine point star, which is of sixth order if  $\Delta x = \Delta y = d$ , but otherwise it is only second order. The nine point star is

given by

$$\begin{aligned}
 u_{i+1j+1} + u_{i-1j+1} + u_{i+1j-1} + u_{i-1j-1} & - 2\frac{\Delta x^2 - 5\Delta y^2}{\Delta x^2 + \Delta y^2}(u_{i+1j} + u_{i-1j}) \\
 & + 2\frac{5\Delta x^2 - \Delta y^2}{\Delta x^2 + \Delta y^2}(u_{ij+1} + u_{ij-1}) - 20u_{ij} = 0
 \end{aligned} \tag{13.5.8}$$

For three dimensional problem the equivalent to five point star is seven point star. It is given by

$$\frac{u_{i-1jk} - 2u_{ijk} + u_{i+1jk}}{(\Delta x)^2} + \frac{u_{ij-1k} - 2u_{ijk} + u_{ij+1k}}{(\Delta y)^2} + \frac{u_{ijk-1} - 2u_{ijk} + u_{ijk+1}}{(\Delta z)^2} = 0. \tag{13.5.9}$$

The solution is obtained by solving the linear system of equations

$$A\mathbf{u} = \mathbf{b}, \tag{13.5.10}$$

where the block banded matrix  $A$  is given by

$$A = \begin{bmatrix} T & B & 0 & \cdots & 0 \\ B & T & B & & \\ 0 & B & T & B & \\ \cdots & & & & \\ 0 & \cdots & 0 & B & T \end{bmatrix} \tag{13.5.11}$$

and the matrices  $B$  and  $T$  are given by

$$B = -I \tag{13.5.12}$$

$$T = \begin{bmatrix} 4 & -1 & 0 & \cdots & 0 \\ -1 & 4 & -1 & & \\ 0 & -1 & 4 & -1 & 0 \\ \cdots & & & & \\ 0 & \cdots & 0 & -1 & 4 \end{bmatrix} \tag{13.5.13}$$

and the right hand side  $\mathbf{b}$  contains boundary values. If we have Poisson's equation then  $\mathbf{b}$  will also contain the values of the right hand side of the equation evaluated at the center point of the molecule.

One can use Thomas algorithm for block tridiagonal matrices. The system could also be solved by an iterative method such as Jacobi, Gauss-Seidel or successive over relaxation (SOR). Such solvers can be found in many numerical analysis texts. In the next section, we give a little information on each.

Remarks:

1. The solution is obtained in one step since there is no time dependence.
2. One can use ELLPACK (ELLiptic PACKage, a research tool for the study of numerical methods for solving elliptic problems, see Rice and Boisvert (1984)) to solve any elliptic PDEs.

### 13.5.1 Iterative solution

The idea is to start with an initial guess for the solution and iterate using an easy system to solve. The sequence of iterates  $x^{(i)}$  will converge to the answer under certain conditions on the iteration matrix. Here we discuss three iterative scheme. Let's write the coefficient matrix  $A$  as

$$A = D - L - U \quad (13.5.1.1)$$

then one can iterate as follows

$$Dx^{(i+1)} = (L + U)x^{(i)} + b, \quad i = 0, 1, 2, \dots \quad (13.5.1.2)$$

This scheme is called Jacobi's method. At each time step one has to solve a **diagonal** system. The convergence of the iterative procedure depends on the spectral radius of the iteration matrix

$$J = D^{-1}(L + U). \quad (13.5.1.3)$$

If  $\rho(J) < 1$  then the iterative method converges (the speed depends on how small the spectral radius is. (spectral radius of a matrix is defined later and it relates to the modulus of the dominant eigenvalue.) If  $\rho(J) \geq 1$  then the iterative method diverges.

Assuming that the new iterate is a better approximation to the answer, one comes up with Gauss-Seidel method. Here we suggest the use of the component of the new iterate as soon as they become available. Thus

$$(D - L)x^{(i+1)} = Lx^{(i)} + b, \quad i = 0, 1, 2, \dots \quad (13.5.1.4)$$

and the iteration matrix  $G$  is

$$G = (D - L)^{-1}U \quad (13.5.1.5)$$

We can write Gauss Seidel iterative procedure also in componentwise

$$x_k^{(i+1)} = \frac{1}{a_{kk}} \left( b_k - \sum_{j=1}^{k-1} a_{kj}x_j^{(i+1)} - \sum_{j=k+1}^n a_{kj}x_j^{(i)} \right) \quad (13.5.1.6)$$

It can be shown that if

$$|a_{ii}| \geq \sum_{j \neq i} |a_{ij}|, \quad \text{for all } i$$

and if for at least one  $i$  we have a strict inequality and the system is irreducible (i.e. can't break to subsystems to be solved independently) then Gauss Seidel method converges. In the case of Laplace's equation, these conditions are met.

The third method we mention here is called successive over relaxation or SOR for short. The method is based on Gauss-Seidel, but at each iteration we add a step

$$u_{ij}^{(k+1)'} = u_{ij}^{(k)'} + \omega \left( u_{ij}^{(k+1)} - u_{ij}^{(k)'} \right) \quad (13.5.1.7)$$

For  $0 < \omega < 1$  the method is really under relaxation. For  $\omega = 1$  we have Gauss Seidel and for  $1 < \omega < 2$  we have over relaxation. There is no point in taking  $\omega \geq 2$ , because the method will diverge. It can be shown that for Laplace's equation the best choice for  $\omega$  is

$$\omega_{opt} = \frac{2}{1 + \sqrt{1 - \sigma^2}} \quad (13.5.1.8)$$

where

$$\sigma = \frac{1}{1 + \beta^2} \left( \cos \frac{\pi}{p} + \beta^2 \cos \frac{\pi}{q} \right), \quad (13.5.1.9)$$

$$\beta = \frac{\Delta x}{\Delta y}, \quad \text{grid aspect ratio} \quad (13.5.1.10)$$

and  $p, q$  are the number of  $\Delta x, \Delta y$  respectively.

## 13.6 Vector and Matrix Norms

Norms have the following properties

Let

$$\vec{x}, \vec{y} \in \mathbf{R}^n \quad \vec{x} \neq \vec{0} \quad \alpha \in \mathbf{R}$$

1)  $\|\vec{x}\| > 0$

2)  $\|\alpha \vec{x}\| = |\alpha| \|\vec{x}\|$

3)  $\|\vec{x} + \vec{y}\| \leq \|\vec{x}\| + \|\vec{y}\|$

Let  $\vec{x} = \begin{pmatrix} x_1 \\ x_2 \\ \vdots \\ x_n \end{pmatrix}$  then the “integral” norms are:

$$\|\vec{x}\|_1 = \sum_{i=1}^n |x_i| \quad \text{one norm}$$

$$\|\vec{x}\|_2 = \sqrt{\sum_{i=1}^n x_i^2} \quad \text{two norm (Euclidean norm)}$$

$$\|\vec{x}\|_k = \left[ \sum_{i=1}^n |x_i|^k \right]^{1/k} \quad \text{k norm}$$

$$\|\vec{x}\|_\infty = \max_{1 \leq i \leq n} |x_i| \quad \text{infinity norm}$$

Example



$$\vec{x} = \begin{pmatrix} -3 \\ 4 \\ 5 \end{pmatrix}$$

$$\|\vec{x}\|_1 = 12$$

$$\|\vec{x}\|_2 = 5\sqrt{2} \sim 7.071$$

$$\|\vec{x}\|_3 = 5.\overline{9}$$

$$\|\vec{x}\|_4 = 5.569$$

⋮

$$\|\vec{x}\|_\infty = 5$$

### Matrix Norms

Let  $A$  be an  $m \times n$  non-zero matrix (i.e.  $A \in \mathcal{R}^m \times \mathcal{R}^n$ ). Matrix norms have the properties

- 1)  $\|A\| \geq 0$
- 2)  $\|\alpha A\| = |\alpha| \|A\|$
- 3)  $\|A + B\| \leq \|A\| + \|B\|$

#### Definintion

A matrix norm is consistent with vector norms  $\|\cdot\|_a$  on  $\mathcal{R}^n$  and  $\|\cdot\|_b$  on  $\mathcal{R}^m$  with  $A \in \mathcal{R}^m \times \mathcal{R}^n$  if

$$\|A\vec{x}\|_b \leq \|A\| \|\vec{x}\|_a$$

and for the special case that  $A$  is a square matrix

$$\|A\vec{x}\| \leq \|A\| \|\vec{x}\|$$

#### Definintion

Given a vector norm, a corresponding matrix norm for square matrices, called the subordinate matrix norm is defined as

$$\underbrace{l.u.b.}_{\text{least upper bound}} (A) = \max_{\vec{x} \neq \vec{0}} \left\{ \frac{\|A\vec{x}\|}{\|\vec{x}\|} \right\}$$

Note that this matrix norm is consistent with the vector norm because

$$\|A\vec{x}\| \leq l.u.b.(A) \cdot \|\vec{x}\|$$

by definition. Said another way, the  $l.u.b.(A)$  is a measure of the greatest magnification a vector  $\vec{x}$  can obtain, by the linear transformation  $A$ , using the vector norm  $\|\cdot\|$ .

### Examples

For  $\|\cdot\|_\infty$  the subordinate matrix norm is

$$\begin{aligned} l.u.b._\infty(A) &= \max_{\vec{x} \neq \vec{0}} \frac{\|A\vec{x}\|_\infty}{\|\vec{x}\|_\infty} \\ &= \max_{\vec{x} \neq \vec{0}} \left\{ \frac{\max_i \{ |\sum_{k=1}^n a_{ik} x_k| \}}{\max_k \{ |x_k| \}} \right\} \\ &= \max_i \left\{ \sum_{k=1}^n |a_{ik}| \right\} \end{aligned}$$

where in the last equality, we've chosen  $x_k = \text{sign}(a_{ik})$ . The “inf”-norm is sometimes written

$$\|A\|_\infty = \max_{1 \leq i \leq n} \sum_{j=1}^n |a_{ij}|$$

where it is readily seen to be the maximum row sum.

In a similar fashion, the “one”-norm of a matrix can be found, and is sometimes referred to as the column norm, since for a given  $m \times n$  matrix  $A$  it is

$$\|A\|_1 = \max_{1 \leq j \leq n} \{ |a_{1j}| + |a_{2j}| + \cdots + |a_{mj}| \}$$

For  $\|\cdot\|_2$  we have

$$\begin{aligned} l.u.b._2(A) &= \max_{\vec{x} \neq \vec{0}} \frac{\|A\vec{x}\|_2}{\|\vec{x}\|_2} \\ &= \max_{\vec{x} \neq \vec{0}} \sqrt{\frac{\vec{x}^T A^T A \vec{x}}{\vec{x}^T \vec{x}}} = \sqrt{\lambda_{max}(A^T A)} \\ &= \sqrt{\rho(A^T A)} \end{aligned}$$

where  $\lambda_{max}$  is the magnitude of the largest eigenvalue of the symmetric matrix  $A^T A$ , and where the notation  $\rho(A^T A)$  is referred to as the “spectral radius” of  $A^T A$ . Note that if  $A = A^T$  then

$$l.u.b._2(A) = \|A\|_2 = \sqrt{\rho^2(A)} = \rho(A)$$

The spectral radius of a matrix is smaller than any consistent matrix norm of that matrix. Therefore, the largest (in magnitude) eigenvalue of a matrix is the least upper bound of all consistent matrix norms. In mathematical terms,

$$l. u. b. (\|A\|) = |\lambda_{max}| = \rho(A)$$

where  $\|\cdot\|$  is any consistent matrix norm.

To see this, let  $(\lambda_i, \vec{x}_i)$  be an eigenvalue/eigenvector pair of the matrix  $A$ . Then we have

$$A \vec{x}_i = \lambda_i \vec{x}_i$$

Taking consistent matrix norms,

$$\|A \vec{x}_i\| = \|\lambda_i \vec{x}_i\| = |\lambda_i| \|\vec{x}_i\|$$

Because  $\|\cdot\|$  is a consistent matrix norm

$$\|A\| \|\vec{x}_i\| \geq \|A \vec{x}_i\| = |\lambda_i| \|\vec{x}_i\|$$

and dividing out the magnitude of the eigenvector (which must be other than zero), we have

$$\|A\| \geq |\lambda_i| \quad \text{for all } \lambda_i$$

Example Given the matrix

$$A = \begin{pmatrix} -12 & 4 & 3 & 2 & 1 \\ 2 & 10 & 1 & 5 & 1 \\ 3 & 3 & 21 & -5 & -4 \\ 1 & -1 & 2 & 12 & -3 \\ 5 & 5 & -3 & -2 & 20 \end{pmatrix}$$

we can determine the various norms of the matrix  $A$ .

The 1 norm of  $A$  is given by:

$$\|A\|_1 = \max_j \{|a_{1,j}| + |a_{2,j}| + \dots + |a_{5,j}|\}$$

The matrix  $A$  can be seen to have a 1-norm of 30 from the 3<sup>rd</sup> column.

The  $\infty$  norm of  $A$  is given by:

$$\|A\|_\infty = \max_i \{|a_{i,1}| + |a_{i,2}| + \dots + |a_{i,5}|\}$$

and therefore has the  $\infty$  norm of 36 which comes from its 3<sup>rd</sup> row.

To find the “two”-norm of  $A$ , we need to find the eigenvalues of  $A^T A$  which are:

$$52.3239, 157.9076, 211.3953, 407.6951, \text{ and } 597.6781$$

Taking the square root of the largest eigenvalue gives us the 2 norm :  $\|A\|_2 = 24.4475$ .

To determine the spectral radius of  $A$ , we find that  $A$  has the eigenvalues:

$$-12.8462, 9.0428, 12.9628, 23.0237, \text{ and } 18.8170$$

Therefore the spectral radius of  $A$ , (or  $\rho(A)$ ) is 23.0237, which is in fact less than all other norms of  $A$  ( $\|A\|_1 = 30$ ,  $\|A\|_2 = 24.4475$ ,  $\|A\|_\infty = 36$ ).

### 13.7 Matrix Method for Stability

We demonstrate the matrix method for stability on two methods for solving the one dimensional heat equation. Recall that the explicit method can be written in matrix form as

$$\mathbf{u}^{n+1} = A\mathbf{u}^n + \mathbf{b} \quad (13.7.1)$$

where the tridiagonal matrix  $A$  have  $1 - 2r$  on diagonal and  $r$  on the super- and sub-diagonal. The norm of the matrix dictates how fast errors are growing (the vector  $\mathbf{b}$  doesn't come into play). If we check the infinity or 1 norm we get

$$\|A\|_1 = \|A\|_\infty = |1 - 2r| + |r| + |r| \quad (13.7.2)$$

For  $0 < r \leq 1/2$ , all numbers inside the absolute values are non negative and we get a norm of 1. For  $r > 1/2$ , the norms are  $4r - 1$  which is greater than 1. Thus we have conditional stability with the condition  $0 < r \leq 1/2$ .

The Crank Nicholson scheme can be written in matrix form as follows

$$(2I - rT)\mathbf{u}^{n+1} = (2I + rT)\mathbf{u}^n + \mathbf{b} \quad (13.7.3)$$

where the tridiagonal matrix  $T$  has -2 on diagonal and 1 on super- and sub-diagonals. The eigenvalues of  $T$  can be expressed analytically, based on results of section 8.6,

$$\lambda_s(T) = -4 \sin^2 \frac{s\pi}{2N}, \quad s = 1, 2, \dots, N - 1 \quad (13.7.4)$$

Thus the iteration matrix is

$$A = (2I - rT)^{-1}(2I + rT) \quad (13.7.5)$$

for which we can express the eigenvalues as

$$\lambda_s(A) = \frac{2 - 4r \sin^2 \frac{s\pi}{2N}}{2 + 4r \sin^2 \frac{s\pi}{2N}} \quad (13.7.6)$$

All the eigenvalues are bounded by 1 since the denominator is larger than numerator. Thus we have unconditional stability.

## 13.8 Derivative Boundary Conditions

Derivative boundary conditions appear when a boundary is insulated

$$\frac{\partial u}{\partial n} = 0 \quad (13.8.1)$$

or when heat is transferred by radiation into the surrounding medium (whose temperature is  $v$ )

$$-k \frac{\partial u}{\partial n} = H(u - v) \quad (13.8.2)$$

where  $H$  is the coefficient of surface heat transfer and  $k$  is the thermal conductivity of the material.

Here we show how to approximate these two types of boundary conditions in connection with the one dimensional heat equation

$$u_t = ku_{xx}, \quad 0 < x < 1 \quad (13.8.3)$$

$$u(0, t) = g(t) \quad (13.8.4)$$

$$\frac{\partial u(L, t)}{\partial n} = -h(u(L, t) - v) \quad (13.8.5)$$

$$u(x, 0) = f(x) \quad (13.8.6)$$

Clearly one can use backward differences to approximate the derivative boundary condition on the left end ( $x = 1$ ), but this is of first order which will degrade the accuracy in  $x$  everywhere (since the error will propagate to the interior in time). If we decide to use a second order approximation, then we have

$$\frac{u_{N+1}^n - u_{N-1}^n}{2\Delta x} = -h(u_N^n - v) \quad (13.8.7)$$

where  $x_{N+1}$  is a fictitious point outside the interval, i.e.  $x_{N+1} = 1 + \Delta x$ . This will require another equation to match the number of unknowns. We then apply the finite difference equation at the boundary. For example, if we are using explicit scheme then we apply the equation

$$u_j^{n+1} = ru_{j-1}^n + (1 - 2r)u_j^n + ru_{j+1}^n, \quad (13.8.8)$$

for  $j = 1, 2, \dots, N$ . At  $j = N$ , we then have

$$u_N^{n+1} = ru_{N-1}^n + (1 - 2r)u_N^n + ru_{N+1}^n. \quad (13.8.9)$$

Substitute the value of  $u_{N+1}^n$  from (13.8.7) into (13.8.9) and we get

$$u_N^{n+1} = ru_{N-1}^n + (1 - 2r)u_N^n + r[u_{N-1}^n - 2h\Delta x(u_N^n - v)]. \quad (13.8.10)$$

This idea can be implemented with any finite difference scheme.

Suggested Problem: Solve Laplace's equation on a unit square subject to given temperature on right, left and bottom and insulated top boundary. Assume  $\Delta x = \Delta y = h = \frac{1}{4}$ .

## 13.9 Hyperbolic Equations

An important property of hyperbolic PDEs can be deduced from the solution of the wave equation. As the reader may recall the definitions of domain of dependence and domain of influence, the solution at any point  $(x_0, t_0)$  depends only upon the initial data contained in the interval

$$x_0 - ct_0 \leq x \leq x_0 + ct_0.$$

As we will see, this will relate to the so called CFL condition for stability.

### 13.9.1 Stability

Consider the first order hyperbolic

$$u_t + cu_x = 0 \tag{13.9.1.1}$$

$$u(x, 0) = F(x). \tag{13.9.1.2}$$

As we have seen earlier, the characteristic curves are given by

$$x - ct = \text{constant} \tag{13.9.1.3}$$

and the general solution is

$$u(x, t) = F(x - ct). \tag{13.9.1.4}$$

Now consider Lax method for the approximation of the PDE

$$u_j^{n+1} - \frac{u_{j+1}^n + u_{j-1}^n}{2} + c \frac{\Delta t}{\Delta x} \left( \frac{u_{j+1}^n - u_{j-1}^n}{2} \right) = 0. \tag{13.9.1.5}$$

To check stability, we can use either Fourier method or the matrix method. In the first case, we substitute a Fourier mode and find that

$$G = e^{a\Delta t} = \cos \beta - i\nu \sin \beta \tag{13.9.1.6}$$

where the Courant number  $\nu$  is given by

$$\nu = c \frac{\Delta t}{\Delta x}. \tag{13.9.1.7}$$

Thus, for the method to be stable, the amplification factor  $G$  must satisfy

$$|G| \leq 1$$

i.e.

$$\sqrt{\cos^2 \beta + \nu^2 \sin^2 \beta} \leq 1 \tag{13.9.1.8}$$

This holds if

$$|\nu| \leq 1, \tag{13.9.1.9}$$

or

$$c \frac{\Delta t}{\Delta x} \leq 1. \quad (13.9.1.10)$$

Compare this CFL condition to the domain of dependence discussion previously. Note that here we have a complex number for the amplification. Writing it in polar form,

$$G = \cos \beta - i\nu \sin \beta = |G|e^{i\phi} \quad (13.9.1.11)$$

where the phase angle  $\phi$  is given by

$$\phi = \arctan(-\nu \tan \beta). \quad (13.9.1.12)$$

A good understanding of the amplification factor comes from a polar plot of amplitude versus **relative phase** =  $-\frac{\phi}{\pi}$  for various  $\nu$  (see figure 81).

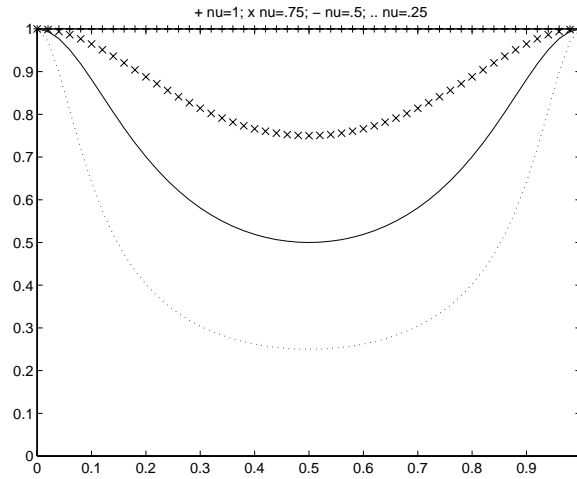

Figure 81: Amplitude versus relative phase for various values of Courant number for Lax Method

Note that the amplitude for all these values of Courant number never exceeds 1. For  $\nu = 1$ , there is no attenuation. For  $\nu < 1$ , the low ( $\phi = 0$ ) and high ( $\phi = -\pi$ ) frequency components are mildly attenuated, while the mid range frequencies are severely attenuated.

Suppose now we solve the same equation using Lax method but we assume periodic boundary conditions, i. e.

$$u_{m+1}^n = u_1^n \quad (13.9.1.13)$$

The system of equations obtained is

$$\mathbf{u}^{n+1} = A\mathbf{u}^n \quad (13.9.1.14)$$

where

$$\mathbf{u}^n = \begin{bmatrix} u_1^n \\ \dots \\ u_m^n \end{bmatrix} \quad (13.9.1.15)$$

$$A = \begin{bmatrix} 0 & \frac{1-\nu}{2} & 0 & \cdots & \frac{1+\nu}{2} \\ \frac{1+\nu}{2} & 0 & \frac{1-\nu}{2} & & \\ 0 & & & & 0 \\ 0 & 0 & \cdots & 0 & \frac{1-\nu}{2} \\ \frac{1-\nu}{2} & \cdots & 0 & \frac{1+\nu}{2} & 0 \end{bmatrix}. \quad (13.9.1.16)$$

It is clear that the eigenvalues of  $A$  are

$$\lambda_j = \cos \frac{2\pi}{m}(j-1) + i\nu \sin \frac{2\pi}{m}(j-1), \quad j = 1, \dots, m. \quad (13.9.1.17)$$

Since the stability of the method depends on

$$|\rho(A)| \leq 1, \quad (13.9.1.18)$$

one obtains the same condition in this case. The two methods yield identical results for periodic boundary condition. It can be shown that this is not the case in general.

If we change the boundary conditions to

$$u_1^{n+1} = u_1^n \quad (13.9.1.19)$$

with

$$u_4^{n+1} = u_3^n \quad (13.9.1.20)$$

to match the wave equation, then the matrix becomes

$$A = \begin{bmatrix} 1 & 0 & 0 & 0 \\ \frac{1+\nu}{2} & 0 & \frac{1-\nu}{2} & 0 \\ 0 & \frac{1+\nu}{2} & 0 & \frac{1-\nu}{2} \\ 0 & 0 & 1 & 0 \end{bmatrix}. \quad (13.9.1.21)$$

The eigenvalues are

$$\lambda_1 = 1, \quad \lambda_2 = 0, \quad \lambda_{3,4} = \pm \frac{1}{2} \sqrt{(1-\nu)(3+\nu)}. \quad (13.9.1.22)$$

Thus the condition for stability becomes

$$-\sqrt{8} - 1 \leq \nu \leq \sqrt{8} - 1. \quad (13.9.1.23)$$

See work by Hirt (1968), Warning and Hyett (1974) and Richtmeyer and Morton (1967).



### 13.9.2 Euler Explicit Method

Euler explicit method for the first order hyperbolic is given by (for  $c > 0$ )

$$\frac{u_j^{n+1} - u_j^n}{\Delta t} + c \frac{u_{j+1}^n - u_j^n}{\Delta x} = 0 \quad (13.9.2.1)$$

or

$$\frac{u_j^{n+1} - u_j^n}{\Delta t} + c \frac{u_{j+1}^n - u_{j-1}^n}{2\Delta x} = 0 \quad (13.9.2.2)$$

Both methods are explicit and first order in time, but also unconditionally **unstable**.

$$G = 1 - \frac{\nu}{2} (2i \sin \beta) \quad \text{for centred difference in space,} \quad (13.9.2.3)$$

$$G = 1 - \nu \left( 2i \sin \frac{\beta}{2} \right) e^{i\beta/2} \quad \text{for forward difference in space.} \quad (13.9.2.4)$$

In both cases the amplification factor is always above 1. The only difference between the two is the spatial order.

### 13.9.3 Upstream Differencing

Euler's method can be made stable if one takes backward differences in space in case  $c > 0$  and forward differences in case  $c < 0$ . The method is called upstream differencing or upwind differencing. It is written as

$$\frac{u_j^{n+1} - u_j^n}{\Delta t} + c \frac{u_j^n - u_{j-1}^n}{\Delta x} = 0, \quad c > 0. \quad (13.9.3.1)$$

The method is of first order in both space and time, it is conditionally stable for  $0 \leq \nu \leq 1$ . The truncation error can be obtained by substituting Taylor series expansions for  $u_{j-1}^n$  and  $u_{j+1}^n$  in (13.9.3.1).

$$\begin{aligned} & \frac{1}{\Delta t} \left\{ \Delta t u_t + \frac{1}{2} \Delta t^2 u_{tt} + \frac{1}{6} \Delta t^3 u_{ttt} + \dots \right\} \\ & + \frac{c}{\Delta x} \left\{ u - \left[ u - \Delta x u_x + \frac{1}{2} \Delta x^2 u_{xx} - \frac{1}{6} \Delta x^3 u_{xxx} \pm \dots \right] \right\} \end{aligned}$$

where all the terms are evaluated at  $x_j, t_n$ .

Thus the truncation error is

$$\begin{aligned} u_t + cu_x &= -\frac{\Delta t}{2} u_{tt} + c \frac{\Delta x}{2} u_{xx} \\ & - \frac{\Delta t^2}{6} u_{ttt} - c \frac{\Delta x^2}{6} u_{xxx} \pm \dots \end{aligned} \quad (13.9.3.2)$$

	$u_t$	$u_x$	$u_{tt}$	$u_{tx}$	$u_{xx}$
coefficients of (9.9.3.2)	1	$c$	$\frac{\Delta t}{2}$	0	$-c\frac{\Delta x}{2}$
$-\frac{\Delta t}{2}\frac{\partial}{\partial t}$ (9.9.3.2)			$-\frac{\Delta t}{2}$	$-c\frac{\Delta t}{2}$	0
$-\frac{c}{2}\Delta t\frac{\partial}{\partial x}$ (9.9.3.2)				$c\frac{\Delta t}{2}$	$\frac{c^2}{2}\Delta t$
$\frac{1}{12}\Delta t^2\frac{\partial^2}{\partial t^2}$ (9.9.3.2)					
$-\frac{1}{3}c\Delta t^2\frac{\partial^2}{\partial t\partial x}$ (9.9.3.2)					
$(\frac{1}{3}c^2\Delta t^2 - c\frac{\Delta t\Delta x}{4})\frac{\partial^2}{\partial x^2}$ (9.9.3.2)					
Sum of coefficients	1	$c$	0	0	$c\frac{\Delta x}{2}(\nu - 1)$

Table 2: Organizing the calculation of the coefficients of the modified equation for upstream differencing

The modified equation is

$$\begin{aligned}
u_t + cu_x &= c\frac{\Delta x}{2}(1 - \nu)u_{xx} - c\frac{\Delta x^2}{6}(2\nu^2 - 3\nu + 1)u_{xxx} \\
&+ O[\Delta x^3, \Delta t\Delta x^2, \Delta x\Delta t^2, \Delta t^3]
\end{aligned}
\tag{13.9.3.3}$$

In the next table we organized the calculations. We start with the coefficients of truncation error, (13.9.3.2), after moving all terms to the left. These coefficients are given in the second row of the table. The first row give the partials of  $u$  corresponding to the coefficients. Now in order to eliminate the coefficient of  $u_{tt}$ , we have to differentiate the first row and multiply by  $-\Delta t/2$ . This will modify the coefficients of other terms. Next we eliminate the new coefficient of  $u_{tx}$ , and so on. The last row shows the sum of coefficients in each column, which are the coefficients of the modified equation.

The right hand side of (13.9.3.3) is the truncation error. The method is of first order. If  $\nu = 1$ , the right hand side becomes zero and the equation is solved **exactly**. In this case the upstream method becomes

$$u_j^{n+1} = u_{j-1}^n$$

which is equivalent to the exact solution using the method of characteristics.

The lowest order term of the truncation error contains  $u_{xx}$ , which makes this term similar to the viscous term in one dimensional fluid flow. Thus when  $\nu \neq 1$ , the upstream differencing introduces an **artificial viscosity** into the solution. Artificial viscosity tends to reduce all gradients in the solution whether physically correct or numerically induced. This effect, which is the direct result of even order derivative terms in the truncation error is called **dissipation**.

	$u_{ttt}$	$u_{ttx}$	$u_{txx}$	$u_{xxx}$
coefficients of (9.9.3.2)	$\frac{\Delta t^2}{6}$	0	0	$c\frac{\Delta x^2}{6}$
$-\frac{\Delta t}{2}\frac{\partial}{\partial t}$ (9.9.3.2)	$-\frac{\Delta t^2}{4}$	0	$c\frac{\Delta x\Delta t}{4}$	0
$-\frac{c}{2}\Delta t\frac{\partial}{\partial x}$ (9.9.3.2)	0	$c\frac{\Delta t^2}{4}$	0	$-c^2\frac{\Delta x\Delta t}{4}$
$\frac{1}{12}\Delta t^2\frac{\partial^2}{\partial t^2}$ (9.9.3.2)	$\frac{1}{12}\Delta t^2$	$c\frac{\Delta t^2}{12}$	0	0
$-\frac{1}{3}c\Delta t^2\frac{\partial^2}{\partial t\partial x}$ (9.9.3.2)		$-\frac{1}{3}c\Delta t^2$	$-\frac{1}{3}c^2\Delta t^2$	0
$(\frac{1}{3}c^2\Delta t^2 - c\frac{\Delta t\Delta x}{4})\frac{\partial^2}{\partial x^2}$ (9.9.3.2)			$\frac{1}{3}c^2\Delta t^2 - c\frac{\Delta t\Delta x}{4}$	$\frac{1}{3}c^3\Delta t^2 - c^2\frac{\Delta t\Delta x}{4}$
Sum of coefficients	0	0	0	$c\frac{\Delta x^2}{6}(2\nu^2 - 3\nu + 1)$

Table 3: Organizing the calculation of the coefficients of the modified equation for upstream differencing

A **dispersion** is a result of the odd order derivative terms. As a result of dispersion, phase relations between waves are distorted. The combined effect of dissipation and dispersion is called **diffusion**. Diffusion tends to spread out sharp dividing lines that may appear in the computational region.

The amplification factor for the upstream differencing is

$$e^{a\Delta t} - 1 + \nu(1 - e^{-i\beta}) = 0$$

or

$$G = (1 - \nu + \nu \cos \beta) - i\nu \sin \beta \quad (13.9.3.4)$$

The amplitude and phase are then

$$|G| = \sqrt{(1 - \nu + \nu \cos \beta)^2 + (-\nu \sin \beta)^2} \quad (13.9.3.5)$$

$$\phi = \arctan \frac{Im(G)}{Re(G)} = \arctan \frac{-\nu \sin \beta}{1 - \nu + \nu \cos \beta}. \quad (13.9.3.6)$$

See figure 82 for polar plot of the amplification factor modulus as a function of  $\beta$  for various values of  $\nu$ . For  $\nu = 1.25$ , we get values outside the unit circle and thus we have instability ( $|G| > 1$ ).

The amplification factor for the exact solution is

$$G_e = \frac{u(t + \Delta t)}{u(t)} = \frac{e^{ik_m[x-c(t+\Delta t)]}}{e^{ik_m[x-ct]}} = e^{-ik_m c \Delta t} = e^{i\phi_e} \quad (13.9.3.7)$$

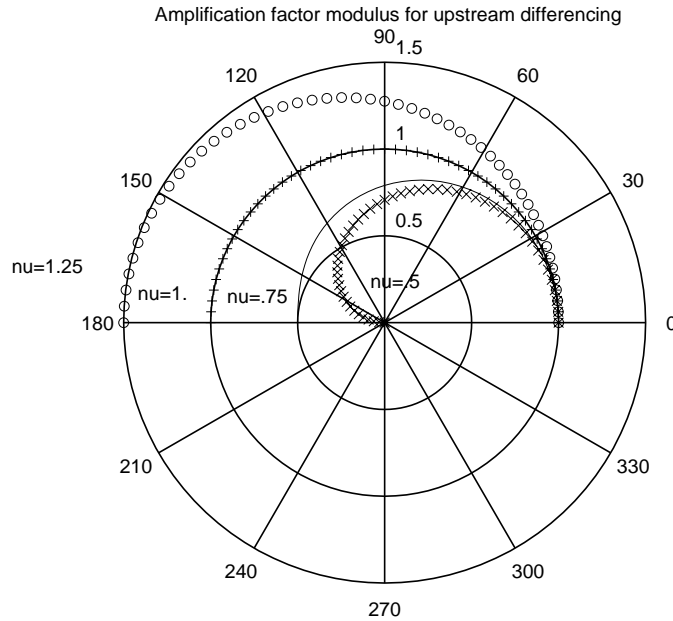

Figure 82: Amplification factor modulus for upstream differencing

Note that the magnitude is 1, and

$$\phi_e = -k_m c \Delta t = -\nu \beta. \quad (13.9.3.8)$$

The total dissipation error in  $N$  steps is

$$(1 - |G|^N) A_0 \quad (13.9.3.9)$$

and the total dispersion error in  $N$  steps is

$$N(\phi_e - \phi). \quad (13.9.3.10)$$

The relative phase shift in one step is

$$\frac{\phi}{\phi_e} = \frac{\arctan \frac{-\nu \sin \beta}{1 - \nu + \nu \cos \beta}}{-\nu \beta}. \quad (13.9.3.11)$$

See figure 83 for relative phase error of upstream differencing. For small  $\beta$  (wave number) the relative phase error is

$$\frac{\phi}{\phi_e} \approx 1 - \frac{1}{6}(2\nu^2 - 3\nu + 1)\beta^2 \quad (13.9.3.12)$$

If  $\frac{\phi}{\phi_e} > 1$  for a given  $\beta$ , the corresponding Fourier component of the numerical solution has a wave speed greater than the exact solution and this is a **leading phase error**, otherwise **lagging phase error**.

The upstream has a leading phase error for  $.5 < \nu < 1$  (outside unit circle) and lagging phase error for  $\nu < .5$  (inside unit circle).

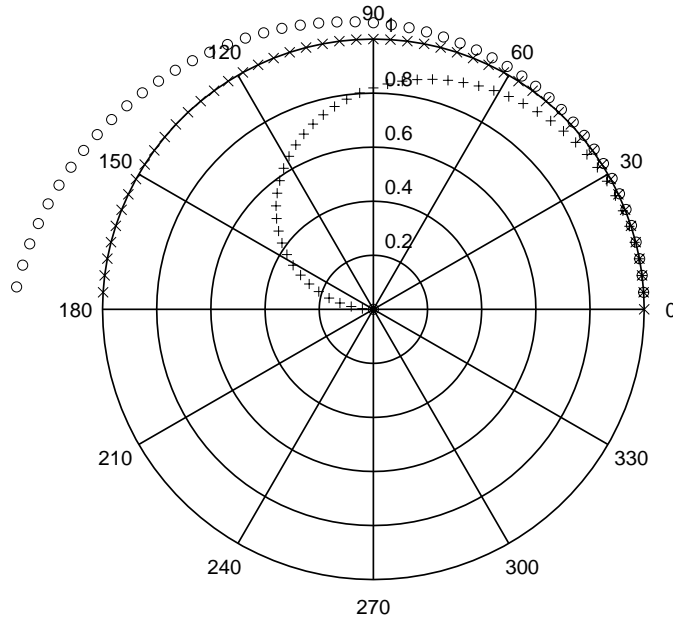

Figure 83: Relative phase error of upstream differencing

### 13.10 Inviscid Burgers' Equation

Fluid mechanics problems are highly nonlinear. The governing PDEs form a nonlinear system that must be solved for the unknown pressures, densities, temperatures and velocities. A single equation that could serve as a nonlinear analog must have terms that closely duplicate the physical properties of the fluid equations, i.e. the equation should have a convective terms ( $uu_x$ ), a diffusive or dissipative term ( $\mu u_{xx}$ ) and a time dependent term ( $u_t$ ). Thus the equation

$$u_t + uu_x = \mu u_{xx} \tag{13.10.1}$$

is parabolic. If the viscous term is neglected, the equation becomes hyperbolic,

$$u_t + uu_x = 0. \tag{13.10.2}$$

This can be viewed as a simple analog of the Euler equations for the flow of an inviscid fluid. The vector form of Euler equations is

$$\frac{\partial U}{\partial t} + \frac{\partial E}{\partial x} + \frac{\partial F}{\partial y} + \frac{\partial G}{\partial z} = 0 \tag{13.10.3}$$

where the vectors  $U, E, F,$  and  $G$  are nonlinear functions of the density ( $\rho$ ), the velocity components ( $u, v, w$ ), the pressure ( $p$ ) and the total energy per unit volume ( $E_t$ ).

$$U = \begin{bmatrix} \rho \\ \rho u \\ \rho v \\ \rho w \\ E_t \end{bmatrix}, \tag{13.10.4}$$

$$E = \begin{bmatrix} \rho u \\ \rho u^2 + p \\ \rho uv \\ \rho uw \\ (E_t + p)u \end{bmatrix}, \quad (13.10.5)$$

$$F = \begin{bmatrix} \rho v \\ \rho uv \\ \rho v^2 + p \\ \rho vw \\ (E_t + p)v \end{bmatrix}, \quad (13.10.6)$$

$$G = \begin{bmatrix} \rho w \\ \rho uw \\ \rho vw \\ \rho w^2 + p \\ (E_t + p)w \end{bmatrix}. \quad (13.10.7)$$

In this section, we discuss the inviscid Burgers' equation (13.10.2). As we have seen in a previous chapter, the characteristics may coalesce and discontinuous solution may form. We consider the scalar equation

$$u_t + F(u)_x = 0 \quad (13.10.8)$$

and if  $u$  and  $F$  are vectors

$$u_t + Au_x = 0 \quad (13.10.9)$$

where  $A(u)$  is the Jacobian matrix  $\frac{\partial F_i}{\partial u_j}$ . Since the equation is hyperbolic, the eigenvalues of the Matrix  $A$  are all real. We now discuss various methods for the numerical solution of (13.10.2).

### 13.10.1 Lax Method

Lax method is first order, as in the previous section, we have

$$u_j^{n+1} = \frac{u_{j+1}^n + u_{j-1}^n}{2} - \frac{\Delta t}{\Delta x} \frac{F_{j+1}^n - F_{j-1}^n}{2}. \quad (13.10.1.1)$$

In Burgers' equation

$$F(u) = \frac{1}{2}u^2. \quad (13.10.1.2)$$

The amplification factor is given by

$$G = \cos \beta - i \frac{\Delta t}{\Delta x} A \sin \beta \quad (13.10.1.3)$$

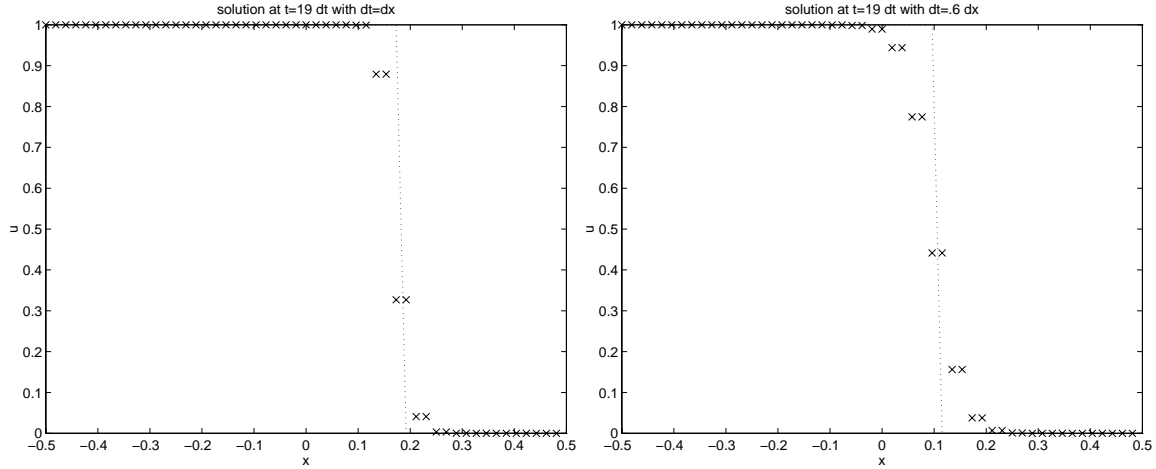

Figure 84: Solution of Burgers' equation using Lax method

where  $A$  is the Jacobian  $\frac{dF}{du}$ , which is just  $u$  for Burgers' equation. The stability requirement is

$$\left| \frac{\Delta t}{\Delta x} u_{max} \right| \leq 1, \quad (13.10.1.4)$$

because  $u_{max}$  is the maximum eigenvalue of the matrix  $A$ . See Figure 84 for the exact versus numerical solution with various ratios  $\frac{\Delta t}{\Delta x}$ . The location of the moving discontinuity is correctly predicted, but the dissipative nature of the method is evident in the smearing of the discontinuity over several mesh intervals. This smearing becomes worse as the Courant number decreases. Compare the solutions in figure 84.

### 13.10.2 Lax Wendroff Method

This is a second order method which one can develop using Taylor series expansion

$$u(x, t + \Delta t) = u(x, t) + \Delta t \frac{\partial u}{\partial t} + \frac{1}{2} (\Delta t)^2 \frac{\partial^2 u}{\partial t^2} + \dots \quad (13.10.2.1)$$

Using Burgers' equation and the chain rule, we have

$$u_t = -F_x = -F_u u_x = -A u_x \quad (13.10.2.2)$$

$$u_{tt} = -F_{tx} = -F_{xt} = -(F_t)_x.$$

Now

$$F_t = F_u u_t = A u_t = -A F_x \quad (13.10.2.3)$$

Therefore

$$u_{tt} = -(-A F_x)_x = (A F_x)_x. \quad (13.10.2.4)$$

Substituting in (13.10.2.1) we get

$$u(x, t + \Delta t) = u(x, t) - \Delta t \frac{\partial F}{\partial x} + \frac{1}{2}(\Delta t)^2 \frac{\partial}{\partial x} \left( A \frac{\partial F}{\partial x} \right) + \dots \quad (13.10.2.5)$$

Now use centered differences for the spatial derivatives

$$\begin{aligned} u_j^{n+1} &= u_j^n - \frac{\Delta t}{\Delta x} \frac{F_{j+1}^n - F_{j-1}^n}{2} \\ &+ \frac{1}{2} \left( \frac{\Delta t}{\Delta x} \right)^2 \left\{ A_{j+1/2}^n (F_{j+1}^n - F_j^n) - A_{j-1/2}^n (F_j^n - F_{j-1}^n) \right\} \end{aligned} \quad (13.10.2.6)$$

where

$$A_{j+1/2}^n = A \left( \frac{u_j^n + u_{j+1}^n}{2} \right). \quad (13.10.2.7)$$

For Burgers' equation,  $F = \frac{1}{2}u^2$ , thus  $A = u$  and

$$A_{j+1/2}^n = \frac{u_j^n + u_{j+1}^n}{2}, \quad (13.10.2.8)$$

$$A_{j-1/2}^n = \frac{u_j^n + u_{j-1}^n}{2}. \quad (13.10.2.9)$$

The amplification factor is given by

$$G = 1 - 2 \left( \frac{\Delta t}{\Delta x} A \right)^2 (1 - \cos \beta) - 2i \frac{\Delta t}{\Delta x} A \sin \beta. \quad (13.10.2.10)$$

Thus the condition for stability is

$$\left| \frac{\Delta t}{\Delta x} u_{max} \right| \leq 1. \quad (13.10.2.11)$$

The numerical solution is given in figure 85. The right moving discontinuity is correctly positioned and sharply defined. The dispersive nature is evidenced in the oscillation near the discontinuity.

The solution shows more oscillations when  $\nu = .6$  than when  $\nu = 1$ . When  $\nu$  is reduced the quality of the solution is degraded.

The flux  $F(u)$  at  $x_j$  and the numerical flux  $f_{j+1/2}$ , to be defined later, must be consistent with each other. The numerical flux is defined, depending on the scheme, by matching the method to

$$u_j^{n+1} = u_j^n - \frac{\Delta t}{\Delta x} \left[ f_{j+1/2}^n - f_{j-1/2}^n \right]. \quad (13.10.2.12)$$

In order to obtain the numerical flux for Lax Wendroff method for solving Burgers' equation, let's add and subtract  $F_j^n$  in the numerator of the first fraction on the right, and substitute



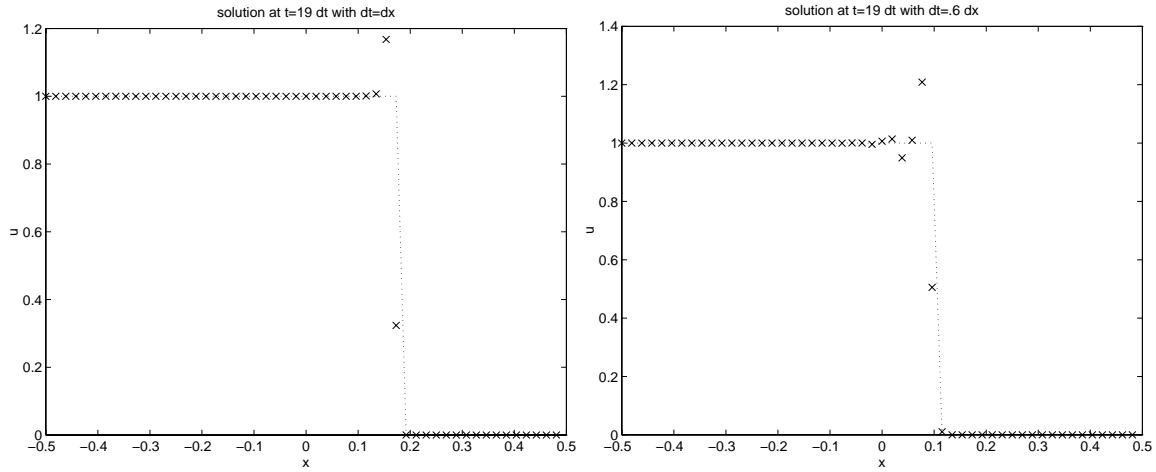

Figure 85: Solution of Burgers' equation using Lax Wendroff method

$u$  for  $A$

$$\begin{aligned}
 u_j^{n+1} = & u_j^n - \frac{\Delta t}{\Delta x} \left\{ \frac{F_{j+1}^n + F_j^n - F_j^n - F_{j-1}^n}{2} \right. \\
 & \left. - \frac{1}{2} \frac{\Delta t}{\Delta x} \left[ \frac{u_j^n + u_{j+1}^n}{2} (F_{j+1}^n - F_j^n) - \frac{u_j^n + u_{j-1}^n}{2} (F_j^n - F_{j-1}^n) \right] \right\}
 \end{aligned} \tag{13.10.2.13}$$

Recall that  $F(u) = \frac{1}{2}u^2$ , and factor the difference of squares to get

$$f_{j+1/2} = \frac{1}{2}(F_j + F_{j+1}) - \frac{1}{2} \frac{\Delta t}{\Delta x} (u_{j+1/2})^2 (u_{j+1} - u_j). \tag{13.10.2.14}$$

The numerical flux for Lax method is given by

$$f_{j+1/2} = \frac{1}{2} \left[ F_j + F_{j+1} - \frac{\Delta x}{\Delta t} (u_{j+1} - u_j) \right]. \tag{13.10.2.15}$$

Lax method is monotone, and Gudonov showed that one **cannot** get higher order than first and keep monotonicity.

### 13.11 Viscous Burgers' Equation

Adding viscosity to Burgers' equation we get

$$u_t + uu_x = \mu u_{xx}. \tag{13.11.1}$$

The equation is now parabolic. In this section we mention analytic solutions for several cases. We assume Dirichlet boundary conditions:

$$u(0, t) = u_0, \tag{13.11.2}$$

$$u(L, t) = 0. \quad (13.11.3)$$

The steady state solution (of course will not require an initial condition) is given by

$$u = u_0 \hat{u} \left\{ \frac{1 - e^{\hat{u} Re_L (x/L - 1)}}{1 + e^{\hat{u} Re_L (x/L - 1)}} \right\} \quad (13.11.4)$$

where

$$Re_L = \frac{u_0 L}{\mu} \quad (13.11.5)$$

and  $\hat{u}$  is the solution of the nonlinear equation

$$\frac{\hat{u} - 1}{\hat{u} + 1} = e^{-\hat{u} Re_L}. \quad (13.11.6)$$

The linearized equation (13.10.1) is

$$u_t + cu_x = \mu u_{xx} \quad (13.11.7)$$

and the steady state solution is now

$$u = u_0 \left\{ \frac{1 - e^{R_L (x/L - 1)}}{1 - e^{-R_L}} \right\} \quad (13.11.8)$$

where

$$R_L = \frac{cL}{\mu}. \quad (13.11.9)$$

The exact unsteady solution with initial condition

$$u(x, 0) = \sin kx \quad (13.11.10)$$

and periodic boundary conditions is

$$u(x, t) = e^{-k^2 \mu t} \sin k(x - ct). \quad (13.11.11)$$

The equations (13.10.1) and (13.11.7) can be combined into a generalized equation

$$u_t + (c + bu)u_x = \mu u_{xx}. \quad (13.11.12)$$

For  $b = 0$  we get the linearized Burgers' equation and for  $c = 0$ ,  $b = 1$ , we get the nonlinear equation. For  $c = \frac{1}{2}$ ,  $b = -1$  the generalized equation (13.11.12) has a steady state solution

$$u = -\frac{c}{b} \left( 1 + \tanh \frac{c(x - x_0)}{2\mu} \right). \quad (13.11.13)$$

Hence if the initial  $u$  is given by (13.11.13), then the exact solution does **not** vary with time. For more exact solutions, see Benton and Platzman (1972).

The generalized equation (13.11.12) can be written as

$$u_t + \hat{F}_x = 0 \quad (13.11.14)$$

where

$$\hat{F} = cu + \frac{1}{2}bu^2 - \mu u_x, \quad (13.11.15)$$

or as

$$u_t + F_x = \mu u_{xx}, \quad (13.11.16)$$

where

$$F = cu + \frac{1}{2}bu^2, \quad (13.11.17)$$

or

$$u_t + A(u)u_x = \mu u_{xx}. \quad (13.11.18)$$

The various schemes described earlier for the inviscid Burgers' equation can also be applied here, by simply adding an approximation to  $u_{xx}$ .

### 13.11.1 FTCS method

This is a Forward in Time Centered in Space (hence the name),

$$\frac{u_j^{n+1} - u_j^n}{\Delta t} + c \frac{u_{j+1}^n - u_{j-1}^n}{2\Delta x} = \mu \frac{u_{j+1}^n - 2u_j^n + u_{j-1}^n}{(\Delta x)^2}. \quad (13.11.1.1)$$

Clearly the method is one step explicit and the truncation error

$$T.E. = O(\Delta t, (\Delta x)^2). \quad (13.11.1.2)$$

Thus it is first order in time and second order in space. The modified equation is given by

$$\begin{aligned} u_t + cu_x &= \left( \mu - \frac{c^2 \Delta t}{2} \right) u_{xx} + c \frac{(\Delta x)^2}{3} \left( 3r - \nu^2 - \frac{1}{2} \right) u_{xxx} \\ &+ c \frac{(\Delta x)^3}{12} \left( \frac{r}{\nu} - 3\frac{r^2}{\nu} - 2\nu + 10\nu r - 3\nu^3 \right) u_{xxxx} + \dots \end{aligned} \quad (13.11.1.3)$$

where as usual

$$r = \mu \frac{\Delta t}{(\Delta x)^2}, \quad (13.11.1.4)$$

$$\nu = c \frac{\Delta t}{\Delta x}. \quad (13.11.1.5)$$

If  $r = \frac{1}{2}$  and  $\nu = 1$ , the first two terms on the right hand side of the modified equation vanish. This is NOT a good choice because it eliminated the viscous term that was originally in the PDE.

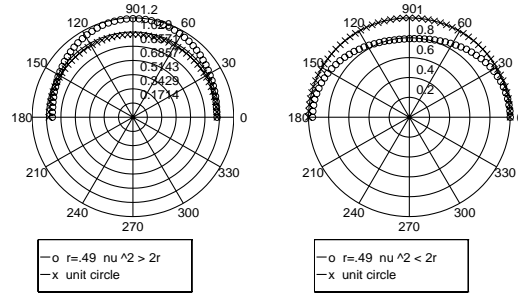

Figure 86: Stability of FTCS method

We now discuss the stability condition. Using Fourier method, we find that the amplification factor is

$$G = 1 + 2r(\cos \beta - 1) - i\nu \sin \beta. \quad (13.11.1.6)$$

In figure 86 we see a polar plot of  $G$  as a function of  $\nu$  and  $\beta$  for  $\nu < 1$  and  $r < \frac{1}{2}$  and  $\nu^2 > 2r$  (left) and  $\nu^2 < 2r$  (right). Notice that if we allow  $\nu^2$  to exceed  $2r$ , the ellipse describing  $G$  will have parts outside the unit circle and thus we have instability. This means that taking the combination of the conditions from the hyperbolic part ( $\nu < 1$ ) and the parabolic part ( $r < \frac{1}{2}$ ) is **not** enough. This extra condition is required to ensure that the coefficient of  $u_{xx}$  is positive, i.e.

$$c^2 \frac{\Delta t}{2} \leq \mu. \quad (13.11.1.7)$$

Let's define the mesh Reynolds number

$$Re_{\Delta x} = \frac{c\Delta x}{\mu} = \frac{\nu}{r}, \quad (13.11.1.8)$$

then the above condition becomes

$$Re_{\Delta x} \leq \frac{2}{\nu}. \quad (13.11.1.9)$$

It turns out that the method is stable if

$$\nu^2 \leq 2r, \quad \text{and } r \leq \frac{1}{2}. \quad (13.11.1.10)$$

This combination implies that  $\nu \leq 1$ . Therefore we have

$$2\nu \leq Re_{\Delta x} \leq \frac{2}{\nu}. \quad (13.11.1.11)$$

For  $Re_{\Delta x} > 2$  FTCS will produce undesirable oscillations. To explain the origin of these oscillations consider the following example. Find the steady state solution of (13.10.1) subject to the boundary conditions

$$u(0, t) = 0, \quad u(1, t) = 1 \quad (13.11.1.12)$$

and the initial condition

$$u(x, 0) = 0, \tag{13.11.1.13}$$

using an 11 point mesh. Note that we can write FTCS in terms of mesh Reynolds number as

$$u_j^{n+1} = \frac{r}{2} (2 - Re_{\Delta x}) u_{j+1}^n + (1 - 2r) u_j^n + \frac{r}{2} (2 + Re_{\Delta x}) u_{j-1}^n. \tag{13.11.1.14}$$

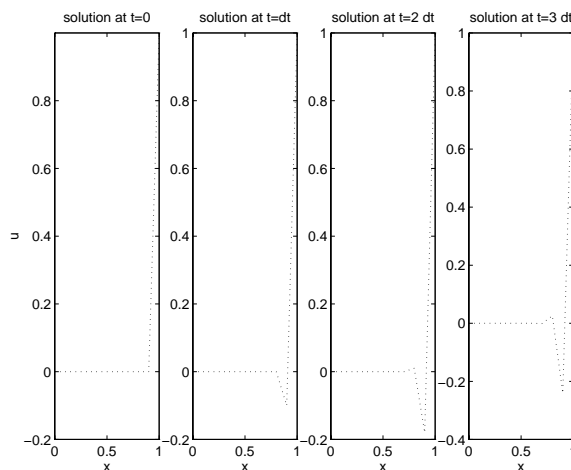

Figure 87: Solution of example using FTCS method

For the first time step

$$u_j^1 = 0, \quad j < 10$$

and

$$u_{10}^1 = \frac{r}{2} (2 - Re_{\Delta x}) < 0, \quad u_{11}^1 = 1,$$

and this will initiate the oscillation. During the next time step the oscillation will propagate to the left. Note that  $Re_{\Delta x} > 2$  means that  $u_{j+1}^n$  will have a negative weight which is physically wrong.

To eliminate the oscillations we can replace the centered difference for  $cu_x$  term by a first order upwind which adds more dissipation. This is too much. Leonard (1979) suggested a third order upstream for the convective term (for  $c > 0$ )

$$\frac{u_{j+1}^n - u_{j-1}^n}{2\Delta x} - \frac{u_{j+1}^n - 3u_j^n + 3u_{j-1}^n - u_{j-2}^n}{6\Delta x}.$$

### 13.11.2 Lax Wendroff method

This is a two step method:

$$\begin{aligned} u_j^{n+1/2} &= \frac{1}{2} (u_{j+1/2}^n + u_{j-1/2}^n) - \frac{\Delta t}{\Delta x} (F_{j+1/2}^n - F_{j-1/2}^n) \\ &+ r \left[ (u_{j-3/2}^n - 2u_{j-1/2}^n + u_{j+1/2}^n) + (u_{j+3/2}^n - 2u_{j+1/2}^n + u_{j-1/2}^n) \right] \end{aligned} \tag{13.11.2.1}$$

The second step is

$$u_j^{n+1} = u_j^n - \frac{\Delta t}{\Delta x} (F_{j+1/2}^{n+1/2} - F_{j-1/2}^{n+1/2}) + r (u_{j+1}^n - 2u_j^n + u_{j-1}^n). \quad (13.11.2.2)$$

The method is first order in time and second order in space. The linear stability condition is

$$\frac{\Delta t}{(\Delta x)^2} (A^2 \Delta t + 2\mu) \leq 1. \quad (13.11.2.3)$$

## 14 Numerical Solution of Nonlinear Equations

### 14.1 Introduction

This chapter is included to give some information on the numerical solution of nonlinear equations. For example, in Chapter 6, we encountered the nonlinear equation

$$\tan x = -\alpha x \quad (14.1.1)$$

with  $x = \sqrt{\lambda}L$  and  $\alpha = \frac{1}{hL}$ , when trying to compute the eigenvalues of (6.2.12).

We will give several methods for obtaining an approximate solution to the problem

$$f(x) = 0. \quad (14.1.2)$$

Fortran codes will also be supplied in the Appendix.

In general the methods for the solution of nonlinear equations are divided into three categories (see Neta (1990)): Bracketing methods, fixed point methods and hybrid schemes. In the following sections, we describe several methods in each of the first two categories.

### 14.2 Bracketing Methods

In this section we discuss algorithms which bracket the zero of the given function  $f(x)$ . In all these methods, one assumes that an interval  $(a, b)$  is given on which  $f(x)$  changes its sign, i.e.,  $f(a)f(b) < 0$ . The methods yield successively smaller intervals containing the zero  $\xi$  known to be in  $(a, b)$ .

The oldest of such methods is called *bisection* or *binary search* method and is based upon the Intermediate Value Theorem. Suppose  $f(x)$  is defined and continuous on  $[a, b]$ , with  $f(a)$  and  $f(b)$  of opposite sign. Then there exists a point  $\xi$ ,  $a < \xi < b$ , for which  $f(\xi) = 0$ . In order to find  $\xi$  we successively half the interval and check which subinterval contains the zero. Continue with that interval until the length of the resulting subinterval is "small enough."

*Bisection algorithm*

Given  $f(x) \in C[a, b]$ , where  $f(a)f(b) < 0$ .

1. Set  $a_1 = a, b_1 = b, i = 1$ .
2. Set  $x_M^i = \frac{1}{2}(a_i + b_i)$ .
3. If  $|f(x_M^i)|$  is small enough or the interval is small enough go to step 8.
4. If  $f(x_M^i)f(a_i) < 0$ , go to step 6.
5. Set  $a_{i+1} = x_M^i, b_{i+1} = b_i$ , go to step 7.
6. Set  $a_{i+1} = a_i, b_{i+1} = x_M^i$ .
7. Add 1 to  $i$ , go to step 2.
8. The procedure is complete.

*Remark* : The stopping criteria to be used are of three types.

- i. The length of the interval is smaller than a prescribed tolerance.
- ii. The absolute value of  $f$  at the point  $x_M^i$  is below a prescribed tolerance.
- iii. The number of iterations performed has reached the maximum allowed.

The last criterion is not necessary in this case of bisection since one can show that the number of iterations  $N$  required to bracket a root  $\xi$  in the interval  $(a, b)$  to a given accuracy  $\tau$  is

$$N = \log_2 \frac{|b - a|}{\tau} \quad (14.2.1)$$

*Remark* : This algorithm will work if the interval contains an *odd* number of zeros counting multiplicities. A multiple zero of even multiplicity cannot be detected by any bracketing method. In such a case one has to use fixed point type methods described in the next section.

### *Regula Falsi*

The bisection method is easy to implement and analyze but converges slowly. In many cases, one can improve by using the method of *linear interpolation* or *Regula Falsi*. Here one takes the zero of the linear function passing through the points  $(a, f(a))$  and  $(b, f(b))$  instead of the midpoint. It is clear that the rate of convergence of the method depends on the size of the second derivative.

#### *Regula Falsi Algorithm*

Given  $f(x) \in C[a, b]$ , where  $f(a)f(b) < 0$ .

1. Set  $x_1 = a, x_2 = b, f_1 = f(a), f_2 = f(b)$ .
2. Set  $x_3 = x_2 - f_2 \frac{x_2 - x_1}{f_2 - f_1}, f_3 = f(x_3)$ .
3. If  $|f_3|$  is small enough or  $|x_2 - x_1|$  is small enough, go to step 7.
4. If  $f_3 f_1 < 0$ , go to step 6.
5.  $x_1 = x_3, f_1 = f_3$ , go to step 2.
6.  $x_2 = x_3, f_2 = f_3$ , go to step 2.
7. The procedure is complete.

*Remark* : This method may converge slowly (approaching the root one sidedly) if the curvature of  $f(x)$  is large enough. To avoid such difficulty the method is modified in the next algorithm called *Modified Regula Falsi*.

#### *Modified Regula Falsi Algorithm*

Given  $f(x) \in C[a, b]$ , where  $f(a)f(b) < 0$ ,

1. Set  $x_1 = a, x_2 = b, f_1 = f(a), f_2 = f(b), S = f_1$ .
2. Set  $x_3 = x_2 - f_2 \frac{x_2 - x_1}{f_2 - f_1}, f_3 = f(x_3)$ .
3. If  $|f_3|$  or  $|x_2 - x_1|$  is small enough, go to step 8.
4. If  $f_3 f_1 < 0$ , go to step 6.
5. Set  $x_1 = x_3, f_1 = f_3$ . If  $f_3 S > 0$  set  $f_2 = f_2/2$ , go to step 7.



6. Set  $x_2 = x_3, f_2 = f_3$ . If  $f_3 S > 0$ , set  $f_1 = f_1/2$ .
7. Set  $S = f_3$ , go to step 2.
8. The procedure is complete.

### 14.3 Fixed Point Methods

The methods in this section do not have the bracketing property and do *not* guarantee convergence for all continuous functions. However, when the methods converge, they are much faster generally. Such methods are useful in case the zero is of even multiplicity. The methods are derived via the concept of the fixed point problem. Given a function  $f(x)$  on  $[a, b]$ , we construct an auxiliary function  $g(x)$  such that  $\xi = g(\xi)$  for all zeros  $\xi$  of  $f(x)$ . The problem of finding such  $\xi$  is called the fixed point problem and  $\xi$  is then called a fixed point for  $g(x)$ . The question is how to construct the function  $g(x)$ . It is clear that  $g(x)$  is not unique. The next problem is to find conditions under which  $g(x)$  should be selected.

*Theorem* If  $g(x)$  maps the interval  $[a, b]$  into itself and  $g(x)$  is continuous, then  $g(x)$  has *at least* one fixed point in the interval.

*Theorem* Under the above conditions and

$$|g'(x)| \leq L < 1 \quad \text{for all } x \in [a, b] \quad (14.3.1)$$

then there exists *exactly one* fixed point in the interval.

#### *Fixed Point Algorithm*

This algorithm is often called Picard iteration and will give the fixed point of  $g(x)$  in the interval  $[a, b]$ .

Let  $x_0 \in [a, b]$  and construct the sequence  $\{x_n\}$  such that

$$x_{n+1} = g(x_n), \quad \text{for all } n \geq 0. \quad (14.3.2)$$

Note that at each step the method gives one value of  $x$  approximating the root and *not* an interval containing it.

*Remark*: If  $x_n = \xi$  for some  $n$ , then

$$x_{n+1} = g(x_n) = g(\xi) = \xi, \quad (14.3.3)$$

and thus the sequence stays *fixed* at  $\xi$ .

*Theorem* Under the conditions of the last theorem, the error  $e_n \equiv x_n - \xi$  satisfies

$$|e_n| \leq \frac{L^n}{1-L} |x_1 - x_0|. \quad (14.3.4)$$

Note that the theorem ascertains convergence of the fixed point algorithm for *any*  $x_0 \in [a, b]$  and thus is called a global convergence theorem. It is generally possible to prove only a *local* result.

This linearly convergent algorithm can be accelerated by using *Aitken's-  $\Delta^2$  method*. Let  $\{x_n\}$  be any sequence converging to  $\xi$ . Form a new sequence  $\{x'_n\}$  by

$$x'_n = x_n - \frac{(\Delta x_n)^2}{\Delta^2 x_n} \quad (14.3.5)$$

where the forward differences are defined by

$$\Delta x_n = x_{n+1} - x_n \quad (14.3.6)$$

$$\Delta^2 x_n = x_{n+2} - 2x_{n+1} + x_n. \quad (14.3.7)$$

Then, it can be shown that  $\{x'_n\}$  converges to  $\xi$  faster than  $\{x_n\}$ , i.e.

$$\lim_{n \rightarrow \infty} \frac{x'_n - \xi}{x_n - \xi} = 0. \quad (14.3.8)$$

### *Steffensen's algorithm*

The above process is the basis for the next method due to *Steffensen*. Each cycle of the method consists of two steps of the fixed point algorithm followed by a correction via *Aitken's-  $\Delta^2$  method*. The algorithm can also be described as follows:

Let  $R(x) = g(g(x)) - 2g(x) + x$

$$G(x) = \begin{cases} x & \text{if } R(x) = 0 \\ x - \frac{(g(x) - x)^2}{R(x)} & \text{otherwise.} \end{cases} \quad (14.3.9)$$

### *Newton's method*

Another second order scheme is the well known Newton's method. There are many ways to introduce the method. Here, first we show how the method is related to the fixed point algorithm. Let  $g(x) = x + h(x)f(x)$ , for some function  $h(x)$ , then a zero  $\xi$  of  $f(x)$  is also a fixed point of  $g(x)$ . To obtain a second order method one must have  $g'(\xi) = 0$ , which is satisfied if  $h(x) = -\frac{1}{f'(x)}$ . Thus, the fixed point algorithm for  $g(x) = x - \frac{f(x)}{f'(x)}$  yields a second order method which is the well known *Newton's method*:

$$x_{n+1} = x_n - \frac{f(x_n)}{f'(x_n)}, \quad n = 0, 1, \dots \quad (14.3.10)$$

For this method one can prove a local convergence theorem, i.e., under certain conditions on  $f(x)$ , there exists an  $\epsilon > 0$  such that Newton's method is quadratically convergent whenever  $|x_0 - \xi| < \epsilon$ .

*Remark* : For a root  $\xi$  of multiplicity  $\mu$  one can modify Newton's method to preserve the quadratic convergence by choosing  $g(x) = x - \mu \frac{f(x)}{f'(x)}$ . This modification is due to Schröder (1957). If  $\mu$  is not known, one can approximate it as described in Traub (1964, pp. 129-130).

## 14.4 Example

In this section, give numerical results demonstrating the three programs in the Appendix to obtain the smallest eigenvalue  $\lambda$  of (6.2.12) with  $L = h = 1$ . That is

$$\tan x = -x \quad (14.4.1)$$

where

$$x = \sqrt{\lambda}. \quad (14.4.2)$$

We first used the bisection method to get the smallest eigenvalue which is in the interval

$$\left(\frac{1}{2}\pi^2, \pi^2\right). \quad (14.4.3)$$

We let  $x \in \left(\frac{1}{2}\pi + .1, \pi\right)$ . The method converges to 1.771588 in 18 iterations.

The other two programs are not based on bracketing and therefore we only need an initial point

$$x_1 = \frac{1}{2}\pi + .1 \quad (14.4.4)$$

instead of an interval. The fixed point (Picard's) method required 6 iterations and Steffensen's method required only 4 iterations. Both converged to a different eigenvalue, namely

$$x = 4.493409.$$

Newton's method on the other hand converges to the first eigenvalue in only 6 iterations.

### RESULTS FROM BISECTION METHOD

ITERATION #	1	R =	0.24062E+01	F(R) =	0.46431E+01
ITERATION #	2	R =	0.20385E+01	F(R) =	0.32002E+01
ITERATION #	3	R =	0.18546E+01	F(R) =	0.15684E+01
ITERATION #	4	R =	0.17627E+01	F(R) =	-0.24196E+00
ITERATION #	5	R =	0.18087E+01	F(R) =	0.82618E+00
ITERATION #	6	R =	0.17857E+01	F(R) =	0.34592E+00
ITERATION #	7	R =	0.17742E+01	F(R) =	0.67703E-01
ITERATION #	8	R =	0.17685E+01	F(R) =	-0.82850E-01
ITERATION #	9	R =	0.17713E+01	F(R) =	-0.65508E-02
ITERATION #	10	R =	0.17728E+01	F(R) =	0.30827E-01
ITERATION #	11	R =	0.17721E+01	F(R) =	0.12201E-01
ITERATION #	12	R =	0.17717E+01	F(R) =	0.28286E-02
ITERATION #	13	R =	0.17715E+01	F(R) =	-0.18568E-02
ITERATION #	14	R =	0.17716E+01	F(R) =	0.48733E-03
ITERATION #	15	R =	0.17716E+01	F(R) =	-0.68474E-03

ITERATION # 16 R = 0.17716E+01 F(R) = -0.11158E-03  
ITERATION # 17 R = 0.17716E+01 F(R) = 0.18787E-03  
ITERATION # 18 R = 0.17716E+01 F(R) = 0.38147E-04  
TOLERANCE MET

RESULTS FROM NEWTON'S METHOD

1 0.1670796D+01  
2 0.1721660D+01 0.1759540D+01  
3 0.1759540D+01 0.1770898D+01  
4 0.1770898D+01 0.1771586D+01  
5 0.1771586D+01 0.1771588D+01  
6 0.1771588D+01 0.1771588D+01

X TOLERANCE MET X= 0.1771588D+01

RESULTS FROM STEFFENSEN'S METHOD

1 0.1670796D+01  
2 0.4477192D+01  
3 0.4493467D+01  
4 0.4493409D+01

X TOLERANCE MET X= 0.4493409D+01

RESULT FROM FIXED POINT (PICARD) METHOD

1 0.1670796D+01  
2 0.4173061D+01  
3 0.4477192D+01  
4 0.4492641D+01  
5 0.4493373D+01  
6 0.4493408D+01

X TOLERANCE MET X= 0.4493408D+01

## 14.5 Appendix

The first program given utilizes bisection method to find the root.

```
C      THIS PROGRAM COMPUTES THE SOLUTION OF F(X)=0 ON THE
C      INTERVAL (X1,X2)
C
C      ARGUMENT LIST
C      X1          LEFT HAND LIMIT
C      X2          RIGHT HAND LIMIT
C      XTOL        INCREMENT TOLERANCE OF ORDINATE
C      FTOL        FUNCTION TOLERANCE
C
C      F1          FUNCTION EVALUATED AT X1
C      F2          FUNCTION EVALUATED AT X2
C      IN IS THE INDEX OF THE EIGENVALUE SOUGHT
      IN=1
      PI=4.*ATAN(1.)
      MITER=10
      FTOL=.0001
      XTOL=.00001
      X1=((IN-.5)*PI)+.1
      X2=IN*PI
      WRITE(6,6) X1,X2
6      FORMAT(1X,'X1 X2',2X,2E14.7)
      F1 = F(X1,IN)
      F2 = F(X2,IN)
C      FIRST, CHECK TO SEE IF A ROOT EXISTS OVER THE INTERVAL
      IF(F1*F2.GT.0.0) THEN
      WRITE(6,1) F1,F2
1      FORMAT(1X,'F(X1) AND F(X2) HAVE SAME SIGN',2X,2E14.7)
      RETURN
      END IF
C
C      SUCCESSIVELY HALVE THE INTERVAL; EVALUATING F(R) AND TOLERANCES
C
      DO 110 I = 1,MITER
C      R          VALUE OF ROOT AFTER EACH ITERATION
      R = (X1+X2)/2.
C      XERR        HALF THE DISTANCE BETWEEN RIGHT AND LEFT LIMITS
C      FR          FUNCTION EVALUATED AT R
      FR = F(R,IN)
      XERR = ABS(X1-X2)/2.
```

```

        WRITE(6,2) I, R, FR
2       FORMAT(1X,'AFTER ITERATION #',1X,I2,3X,'R =',1X,E14.7,3X,
1'F(R) =',1X,E14.7)
C
C       CHECK TOLERANCE OF ORDINATE
C
        IF (XERR.LE.XTOL) THEN
        WRITE (6,3)
3       FORMAT(1X,'TOLERANCE MET')
        RETURN
        ENDIF
C
C       CHECK TOLERANCE OF FUNCTION
C
        IF(ABS(FR).LE.FTOL) THEN
        WRITE(6,3)
        RETURN
        ENDIF
C
C       IF TOLERANCES HAVE NOT BEEN MET, RESET THE RIGHT AND LEFT LIMITS
C       AND CONTINUE ITERATION
C
        IF(FR*F1.GT.0.0) THEN
        X1 = R
        F1=FR
        ELSE
        X2 = R
        F2 = FR
        END IF
110    CONTINUE
        WRITE (6,4) MITER
4       FORMAT(1X,'AFTER',I3,'ITERATIONS - ROOT NOT FOUND')
        RETURN
        END
        FUNCTION F(X,IN)
C       THE FUNCTION FOR WHICH THE ROOT IS DESIRED
        F=X+TAN(X)+IN*PI
        RETURN
        END

```

The second program uses the fixed point method.

```
C
C   FIXED POINT METHOD
C
      IMPLICIT REAL*8 (A-H,O-Z)
      PI=4.DO+DATAN(1.DO)
C   COUNT NUMBER OF ITERATIONS
      N=1
C   XTOL= X TOLERANCE
      XTOL=.0001
C   FTOL IS F TOLERANCE
      FTOL=.00001
C   INITIAL POINT
C   IN IS THE INDEC OF THE EIGENVALUE SOUGHT
      IN=1
      X1=(IN-.5)*PI+.1
C   MAXIMUM NUMBER OF ITERATIONS
      MITER=10
      I=1
      PRINT 1,I,X1
10   X2=G(X1)
1   FORMAT(1X,I2,D14.7)
      N=N+1
      RG=G(X2,IN)
      PRINT 1,N,X2,RG
      IF(DABS(X1-X2).LE.XTOL) GO TO 20
      IF(DABS(RG).LE.FTOL) GO TO 30
      X1=X2
      IF(N.LE.MITER) GO TO 10
20  CONTINUE
      PRINT 2,X2
2   FORMAT(2X,'X TOLERANCE MET   X=',D14.7)
      RETURN
30  PRINT 3,X2
3   FORMAT(3X,'F TOLERANCE MET   X=',D14.7)
      RETURN
      END
      FUNCTION G(X,IN)
      IMPLICIT REAL*8 (A-H,O-Z)
      G=DATAN(X)+IN*PI
```

RETURN  
END



The last program uses Newton's method.

```
C
C   NEWTON'S METHOD
C
      IMPLICIT REAL*8 (A-H,O-Z)
      PI=4.DO+DATAN(1.DO)
C   COUNT NUMBER OF ITERATIONS
      N=1
C   XTOL= X TOLERANCE
      XTOL=.0001
C   FTOL IS F TOLERANCE
      FTOL=.00001
C   INITIAL POINT
C   IN IS THE INDEC OF THE EIGENVALUE SOUGHT
      IN=1
      X1=(IN-.5)*PI+.1
C   MAXIMUM NUMBER OF ITERATIONS
      MITER=10
      PRINT 1,N,X1
10   X2=G(X1,IN)
1   FORMAT(1X,I2,D14.7,1X,D14.7)
      N=N+1
      RG=G(X2,IN)
      PRINT 1,N,X2,RG
      IF(DABS(X1-X2).LE.XTOL) GO TO 20
      IF(DABS(RG).LE.FTOL) GO TO 30
      X1=X2
      IF(N.LE.MITER) GO TO 10
20  CONTINUE
      PRINT 2,X2
2   FORMAT(2X,'X TOLERANCE MET   X=',D14.7)
      RETURN
30  PRINT 3,X2
3   FORMAT(3X,'F TOLERANCE MET   X=',D14.7)
      RETURN
      END
      FUNCTION G(X,IN)
      IMPLICIT REAL*8 (A-H,O-Z)
      G=X-F(X,IN)/FP(X,IN)
      RETURN
```

```
END
FUNCTION F(X, IN)
IMPLICIT REAL*8 (A-H, O-Z)
PI=4.DO+DATAN(1.DO)
F=X+DTAN(X)+IN*PI
RETURN
END
FUNCTION FP(X, IN)
IMPLICIT REAL*8 (A-H, O-Z)
PI=4.DO+DATAN(1.DO)
FP=1.DO+(1.DO/DCOS(X))**2
RETURN
END
```

## References

- Abramowitz, M., and Stegun, I., *Handbook of Mathematical Functions*, Dover Pub. Co. New York, 1965.
- Aitken, A.C., *On Bernoulli's numerical solution of algebraic equations*, Proc. Roy. Soc. Edinburgh, Vol.46(1926), pp. 289-305.
- Aitken, A.C., *Further numerical studies in algebraic equations*, Proc. Royal Soc. Edinburgh, Vol. 51(1931), pp. 80-90.
- Anderson, D. A., Tannehill J. C., and Pletcher, R. H., *Computational Fluid Mechanics and Heat Transfer*, Hemisphere Pub. Co. New York, 1984.
- Beck, J. V., Cole, K. D., Haji-Sheikh, A., and Litkouhi, B., *Heat Conduction Using Green's Functions*, Hemisphere Pub. Co. London, 1991.
- Boyce, W. E. and DiPrima, R. C., *Elementary Differential Equations and Boundary Value Problems*, Fifth Edition, John Wiley & Sons, New York, 1992.
- Cochran J. A., *Applied Mathematics Principles, Techniques, and Applications*, Wadsworth International Mathematics Series, Belmont, CA, 1982.
- Coddington E. A. and Levinson N., *Theory of Ordinary Differential Equations* , McGraw Hill, New York, 1955.
- Courant, R. and Hilbert, D., *Methods of Mathematical Physics*, Interscience, New York, 1962.
- Fletcher, C. A. J., *Computational Techniques for Fluid Dynamics, Vol. I: Fundamental and General Techniques*, Springer Verlag, Berlin, 1988.
- Garabedian, P. R., *Partial Differential Equations*, John Wiley and Sons, New York, 1964.
- Haberman, R., *Elementary Applied Partial Differential Equations with Fourier Series and Boundary Value Problems*, Prentice Hall, Englewood Cliffs, New Jersey, 1983.
- Haltiner, G. J. and Williams, R. T., *Numerical Prediction and Dynamic Meteorology*, John Wiley & Sons, New York, 1980.
- Hinch, E. J., *Perturbation Methods*, Cambridge University Press, Cambridge, United Kingdom, 1991.
- Hirt, C. W., *Heuristic Stability Theory for Finite-Difference Equations*, Journal of Computational Physics, Volume 2, 1968, pp. 339-355.
- John, F., *Partial Differential Equations*, Springer Verlag, New York, 1982.
- Lapidus, L. and Pinder, G. F., *Numerical Solution of Partial Differential Equations in Science and Engineering*, John Wiley & Sons, New York, 1982.
- Myint-U, T. and Debnath, L., *Partial Differential Equations for Scientists and Engineers*, North-Holland, New York, 1987.

- Neta, B., *Numerical Methods for the Solution of Equations*, Net-A-Sof, Monterey, CA, 1990.
- Pedlosky, J., *Geophysical Fluid Dynamics*, Springer Verlag, New York, 1986.
- Pinsky, M., *Partial Differential Equations and Boundary-Value Problems with Applications*, Springer Verlag, New York, 1991.
- Richtmeyer, R. D. and Morton, K. W., *Difference Methods for Initial Value Problems*, second edition, Interscience Pub., Wiley, New York, 1967.
- Rice, J. R., and R. F. Boisvert, *Solving elliptic problems using ELLPACK*, Springer Verlag, New York, 1984.
- Schröder, E., *Über unendlich viele Algorithmen zur Auflösung der Gleichungen*, Math. Ann., Vol. 2(1870), pp. 317-365.
- Schröder, J., *Über das Newtonsche Verfahren*, Arch. Rational Mech. Anal., Vol. 1(1957), pp. 154-180.
- Smith, G. D., *Numerical Solution of Partial Differential Equations: Finite Difference Methods*, third edition, Oxford University Press, New York, 1985.
- Staniforth, A. N., Williams, R. T., and Neta, B., *Influence of linear depth variation on Poincaré, Kelvin, and Rossby waves*, Monthly Weather Review, Vol. 50(1993) pp. 929-940.
- Steffensen, J.F., *Remarks on iteration*, Skand. Aktuar. Tidskr., Vol. 16(1934) p. 64.
- Traub, J.F., *Iterative Methods for the Solution of Equations*, Prentice Hall, New York, 1964.
- Warming, R. F. and Hyett, B. J., *The Modified Equation Approach to the Stability and Accuracy Analysis of Finite-Difference Methods*, Journal of Computational Physics, Volume 14, 1974, pp. 159-179.

# Index

- ADI, 302
- adjoint operator, 254
- Advection, 37
- advection diffusion equation, 5
- advection equation, 288
- Aitken's method, 334
- amplification factor, 290
- approximate factorization, 304
- artificial viscosity, 318
- associated Legendre equation, 172
- associated Legendre polynomials, 174
- averaging operator, 279
  
- backward difference operator, 279
- Bassett functions, 166
- Bessel functions, 159
- Bessel's equation, 159
- best approximation, 96
- binary search, 331
- bisection, 331, 337
- boundary conditions of the third kind, 127
- bracketing, 335
- Bracketing methods, 331
  
- canonical form, 15, 16, 19, 20, 23, 26, 30, 33
- causality principle, 245
- centered difference, 279
- CFL condition, 314, 315
- characteristic curves, 15, 19, 20
- characteristic equations, 20
- characteristics, 16, 19
- chemical reactions, 120
- Circular Cylinder, 164
- circular membrane, 158
- Circularly symmetric, 121
- coefficients, 88
- compact fourth order, 279
- compatible, 289
- conditionally stable, 290
- confluent hypergeometric functions, 137, 138
- conservation-law form, 53
- conservative form, 53
- consistent, 289
- Convergence, 97
- convergence, 88
- convergent, 291
- Convolution theorem, 268
- convolution theorem, 204, 210
  
- Convolution theorem for Fourier cosine transform, 210
- Convolution theorem for Fourier sine transform, 210
- Coriolis parameter, 137
- Courant number, 314
- Crank-Nicholson, 295, 299, 302, 303
- curved boundary, 281
- cylindrical, 147
  
- d'Alembert's solution, 58
- delta function, 246
- diffusion, 319
- diffusion-convection equation, 207
- Dirac delta function, 228, 229
- Dirichlet, 7
- Dirichlet boundary conditions, 148
- dispersion, 291, 319
- dissipation, 318
- divergence form, 53
- domain of dependence, 59
- domain of influence, 59
- DuFort Frankel, 294
- DuFort-Frankel scheme, 289
  
- eigenfunctions, 76, 83, 182
- eigenvalues, 76, 83
- elliptic, 4, 15, 17, 36
- ELLPACK, 306
- equilibrium problems, 15
- error function, 201
- Euler equations, 321
- Euler explicit method, 317
- Euler's equation, 114, 171
- even function, 64
- explicit scheme, 292
  
- finite difference methods, 287
- finite string, 273
- first order wave equation, 37
- five point star, 305
- fixed point, 333, 335
- fixed point method, 339
- fixed point methods, 331
- forced vibrations, 186
- forward difference operator, 279
- Fourier, 290
- Fourier cosine series, 99
- Fourier cosine transform, 208
- Fourier method, 314

Fourier series, 85, 88  
 Fourier sine series, 99  
 Fourier sine transform, 208  
 Fourier transform, 195, 196, 218  
 Fourier transform method, 195  
 Fourier transform of spatial derivatives, 204  
 Fourier transform of time derivatives, 204  
 Fredholm alternative, 233  
 Fredholm integral equation, 226  
 fundamental period, 64, 85

Gauss-Seidel, 306  
 Gauss-Seidel method, 307  
 Gaussian, 196, 200  
 generalized Fourier series, 122  
 Gibbs phenomenon, 90, 115  
 Green's formula, 131, 254  
 Green's function, 218, 222, 225, 229, 242  
 Green's theorem, 234  
 grid, 287  
 grid aspect ratio, 308

heat conduction, 5  
 heat equation, 4  
 heat equation in one dimension, 292  
 heat equation in two dimensions, 302  
 heat equation on infinite domain, 252  
 heat equation on infinite domains, 265  
 heat flow, 121  
 Heaviside function, 229  
 Helmholtz equation, 149, 151, 158  
 Helmholtz operator, 258  
 homogeneous, 2  
 hybrid schemes, 331  
 hyperbolic, 4, 15–17, 19, 20, 32  
 hyperbolic Bessel functions, 166

implicit scheme, 296  
 influence function, 200  
 inhomogeneous, 2  
 inhomogeneous boundary conditions, 179  
 inhomogeneous wave equation, 186  
 integrating factor, 223  
 Intermediate Value Theorem, 331  
 inverse Fourier transform, 196  
 inverse transform, 267  
 inviscid Burgers' equation, 321  
 irreducible, 307  
 irregular mesh, 281  
 iterative method, 306  
 Iterative solution, 307

Jacobi, 306  
 Jacobi's method, 307

kernel, 226  
 Korteweg-de Vries equation, 207  
 Kummer's equation, 138

lagging phase error, 320  
 Lagrange's identity, 131, 223  
 Lagrange's method, 223  
 Laguerre polynomial, 138  
 Laplace transform, 267  
 Laplace transform of derivatives, 268  
 Laplace's Equation, 304  
 Laplace's equation, 4, 14, 113, 115, 140, 147, 287  
 Laplace's equation in a half plane, 206  
 Laplace's equation in spherical coordinates, 170  
 Lax equivalence theorem, 291  
 Lax method, 314, 315, 322, 325  
 Lax Wendroff, 324, 329  
 leading phase error, 320  
 least squares, 96  
 Legendre polynomial, 140  
 Legendre polynomials, 173  
 Legendre's equation, 172  
 linear, 1  
 linear interpolation, 332

marching problems, 15  
 matrix method, 314  
 Maxwell's reciprocity, 225, 249  
 mesh, 287  
 mesh Reynolds number, 328  
 mesh size, 288  
 method of characteristics, 37, 58, 218  
 method of eigenfunction expansion, 190  
 method of eigenfunctions expansion, 179  
 modes, 76  
 modified Bessel functions, 166  
 modified Green's function, 234, 260  
 Modified Regula Falsi Algorithm, 332

Neumann, 7  
 Neumann boundary condition, 151  
 Neumann functions, 159  
 Newton's law of cooling, 8  
 Newton's method, 334, 341  
 nine point star, 305  
 nonhomogeneous, 120  
 nonhomogeneous problems, 179  
 nonlinear, 2  
 nonlinear equations, 331

nonuniform rod, 120  
 numerical flux, 324  
 numerical methods, 287  
 numerical solution, 331  
  
 odd function, 64  
 one dimensional heat equation, 218  
 one dimensional wave equation, 272  
 order of a PDE, 1  
 orthogonal, 86, 122  
 orthogonal vectors, 86  
 orthogonality, 86  
 orthogonality of Legendre polynomials, 173  
  
 parabolic, 4, 15, 17, 22, 29, 36  
 Parallelogram Rule, 70  
 partial differential equation, 1  
 PDE, 1  
 period, 64, 85  
 periodic, 85  
 Periodic boundary conditions, 8  
 periodic forcing, 187  
 periodic function, 64  
 perturbed, 140  
 phase angle, 315  
 physical applications, 4  
 Picard, 335  
 Picard iteration, 333  
 piecewise continuous, 85  
 piecewise smooth, 85  
 Poisson's equation, 4, 190, 239, 263  
 principle of superposition, 243  
 pulse, 228  
  
 quadratic convergence, 334  
 quasilinear, 2, 44  
  
 Rayleigh quotient, 122, 134, 155  
 Rayleigh quotient, 159  
 Regula Falsi, 332  
 regular, 122  
 regular Sturm-Liouville, 127  
 Residue theorem, 267  
 resonance, 187  
 Runge-Kutta method, 42  
  
 second kind, 226  
 second order wave equation, 58  
 separation of variables, 73, 85, 120, 148, 151, 218  
 series summation, 108  
 seven point star, 306  
 shallow water equations, 137  
 singular Sturm-Liouville, 124  
  
 SOR, 307  
 source-varying Green's function, 255  
 spectral radius, 307  
 spherical, 147  
 stability, 290  
 stable, 290  
 steady state, 15, 222  
 Steffensen's algorithm, 334  
 Steffensen's method, 335  
 stopping criteria, 331  
 Sturm - Liouville differential equation, 121  
 Sturm-Liouville, 155, 222  
 Sturm-Liouville differential equation, 122  
 Sturm-Liouville problem, 122  
 successive over relaxation, 307  
 successive over relaxation (SOR), 306  
  
 Taylor series, 278  
 Term by Term Differentiation, 106  
 Term by Term Integration, 108  
 Thomas algorithm, 282  
 translation property, 257  
 truncation error, 288  
 two dimensional eigenfunctions, 191  
 Two Dimensional Heat Equation, 302  
  
 unconditionally stable, 290  
 unconditionally unstable, 290  
 uniform mesh, 280  
 upstream differencing, 317  
 upwind differencing, 317  
  
 variation of parameters, 183  
 viscous Burgers' equation, 321  
 von Neumann, 290  
  
 Wave equation, 4  
 wave equation, 5  
 wave equation on infinite domain, 245  
 wave equation on infinite domains, 265  
 weak form, 53