



# Standard Test Methods for Impact Testing of Cast Irons<sup>1</sup>

This standard is issued under the fixed designation A 327; the number immediately following the designation indicates the year of original adoption or, in the case of revision, the year of last revision. A number in parentheses indicates the year of last reapproval. A superscript epsilon ( $\epsilon$ ) indicates an editorial change since the last revision or reapproval.

## 1. Scope

1.1 These test methods for impact testing cover the details of apparatus, test specimens and procedures for cast iron, including gray iron, white iron, malleable iron, ductile iron, and austempered ductile iron, but not including chilled rolls or rolls with white iron skins.

1.2 The values stated in inch-pound units are to be regarded as the standard. A companion standard, A 327M, lists values in SI units.

1.3 *This standard does not purport to address all of the safety concerns, if any, associated with its use. It is the responsibility of the user of this standard to establish appropriate safety and health practices and determine the applicability of regulatory limitations prior to use.*

## 2. Referenced Documents

- 2.1 *ASTM Standards:*
- E 23 Test Methods for Notched Bar Impact Testing of Metallic Materials<sup>2</sup>

### METHOD A—ROUND BAR CHARPY-TYPE IMPACT TEST FOR GRAY AND WHITE IRONS

## 3. Scope

3.1 The Charpy-type impact test shall be employed for testing gray and white irons.

## 4. Apparatus

4.1 The single-blow Charpy impact test for gray and white irons shall be carried out in a pendulum-type impact machine with a capacity of at least 110 ft · lbf as used for the simple beam test for steel described in Test Methods E 23.

## 5. Test Specimens

5.1 The test specimens shall have a plain cylindrical form, machined or ground to a smooth finish and shall conform to the following dimensions:

	Type A	Type M
Diameter	1.125 ± 0.002 in.	0.787 ± 0.001 in.
Length	8.0 ± 0.5 in.	4.73 ± 0.08 in.
Span	6.00 ± 0.03 in.	3.937 ± 0.020 in.

## 6. Procedure

6.1 Test the bars on the spans indicated in the tabular data of 5.1. In all other respects, the test shall conform to the appropriate requirements of Test Methods E 23.

6.2 Make the test at room temperature.

6.3 Characterization of the fracture toughness of any cast iron should be based upon testing at least three specimens.

NOTE 1—Care should be taken to examine broken specimens for indication of anvil interference which will give erroneous results.

## 7. Report

7.1 The results shall be reported as \_\_\_\_ ft · lbf cast iron Charpy impact with \_\_\_\_ in. diameter bar.

### METHOD B—STANDARD CHARPY-TYPE IMPACT TEST FOR MALLEABLE AND DUCTILE IRONS

## 8. Scope

8.1 Either the standard notched or unnotched Charpy impact test shall be employed in testing of malleable or ductile irons. Selection of the type bar is dependent upon the specific material to be evaluated as defined in Section 9.

8.2 Both types of Charpy bars have been designated to characterize the fracture toughness of irons. The unnotched Charpy bar, when tested, will produce substantially higher energy values than the notched bar type. The unnotched bar is therefore specified for testing irons that have low fracture toughness characteristics.

## 9. Charpy Test Bar Type

9.1 Unless specified otherwise, the notched bar type specimens in Fig. 1 or Fig. 2 (for pipe type products) shall be employed. Exceptions are defined in 9.2 and 9.3.

9.2 The unnotched Charpy type specimen in Fig. 3 shall be employed for testing of all grades of austempered ductile iron. These irons are tested after the austempering heat treatment.

<sup>1</sup> These test methods are under the jurisdiction of ASTM Committee A-4 on Iron Castings and are the direct responsibility of Subcommittee A04.21 on Testing.

Current edition approved April 15, 1991. Published November 1991. Originally published as A 327 – 50 T. Last previous edition A 327 – 72 (1985).

<sup>2</sup> *Annual Book of ASTM Standards*, Vol 03.01.

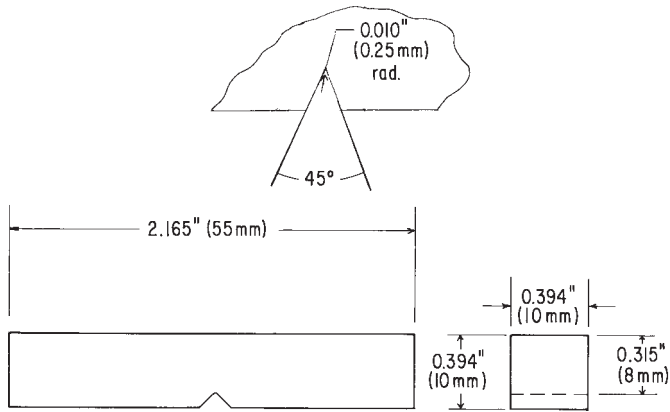

NOTE—Permissible variations shall be as follows:

Adjacent sides shall be at	90° ± 10 min
Cross section dimensions	±0.001 in.
Length of specimen, L	±0, -0.100 in.
Angle of notch	±1°
Radius of notch	±0.001 in.
Dimension to bottom of notch	±0.001 in.
Distance to notch, 1/2	±0.040 in.

FIG. 1 Standard Vee Notch Charpy Bar Impact Test Specimen

9.3 The unnotched Charpy test specimen may be specified for other types of irons or irons that have been heat treated in various ways other than austempering, by specific agreement between producer and purchaser.

10. Apparatus

10.1 The single-blow Charpy test for ductile and malleable iron shall be carried out in a pendulum-type impact machine with a capacity of at least 110 ft · lbf as used for the simple beam test for steel described in Test Methods E 23.

10.2 Standard machines may be modified by using a more sensitive scale, or pendulum machines of a lower capacity may be used where values of less than 25 ft · lbf will be obtained.

11. Test Specimens

11.1 Except for pipe, the test specimen shall have the shape and dimensions as shown in Fig. 1 for notch Charpy bars and Fig. 3 for unnotched Charpy bars. Bars must have a smooth machined or ground surface finish. The notched area of notch type bars shall be free of any burrs or machining marks that could adversely influence test values.

11.2 In the case of malleable or ductile irons that are to be tested after heat treatment, such as austempered ductile irons, final finish grinding of longitudinal faces and cutting of the notch must be performed after completion of all heat treatment operations.

11.3 Test specimens taken from ductile iron pipe shall be 0.500 in. wide, measured from the notched face. The thickness of the notched face shall be equal to the full wall thickness of the pipe (t), except that specimens in which the pipe wall specimen thickness exceeds the maximum height accommodated by the impact test machine shall be machined to a thickness that can be accommodated by the machine. Specimens shall be machined in accordance with Fig. 2.

12. Procedure

12.1 Test the specimen in accordance with the procedures set forth in Test Methods E 23.

12.2 Unless otherwise specified, the test shall be performed at 70 ± 10°F.

12.3 For testing at other than room temperature, accuracy of results is ensured by following the procedure outlined in Test Methods E 23.

12.4 Characterization of the fracture toughness of any cast iron should be based upon testing at least three specimens.

13. Report

13.1 Report the following information:

13.1.1 For malleable or ductile irons, the results shall be reported as ft · lbf at °F, “standard notched Charpy test” or “standard unnotched Charpy test,” depending upon which specimen type was employed.

13.1.2 Impact test results for ductile iron pipe shall be corrected by calculation as follows:

Impact value corrected = [0.40/t] × impact value measured where t is the thickness of the specimen in inches (see Fig. 2 and Note 2).

NOTE 2—The ratio 0.40/t (where t = pipe wall thickness in inches), when multiplied by the measured energy values, normalizes reported energy values for pipe or tube of different wall thicknesses to a standard 0.40 in. wall dimension.

13.1.3 Where tests are conducted at other than room temperature, as defined in 12.2, actual test temperature in the samples themselves at the time of testing shall be recorded and reported with the determined energy values. These temperatures shall be measured and reported to ±2°F.

14. Precision and Bias

14.1 Precision—No statement on precision is currently available. The test methods for impact testing in A 327 and A 327 M are based on referenced Test Methods E 23. Determination of precision for Test Methods E 23 is currently under evaluation in Judicial Committee E-28 on Mechanical Testing.

14.2 Bias—Since no acceptable single reference material for determining bias in measuring impact energy for the variety of cast irons covered by these test methods has been identified, bias has not been established.

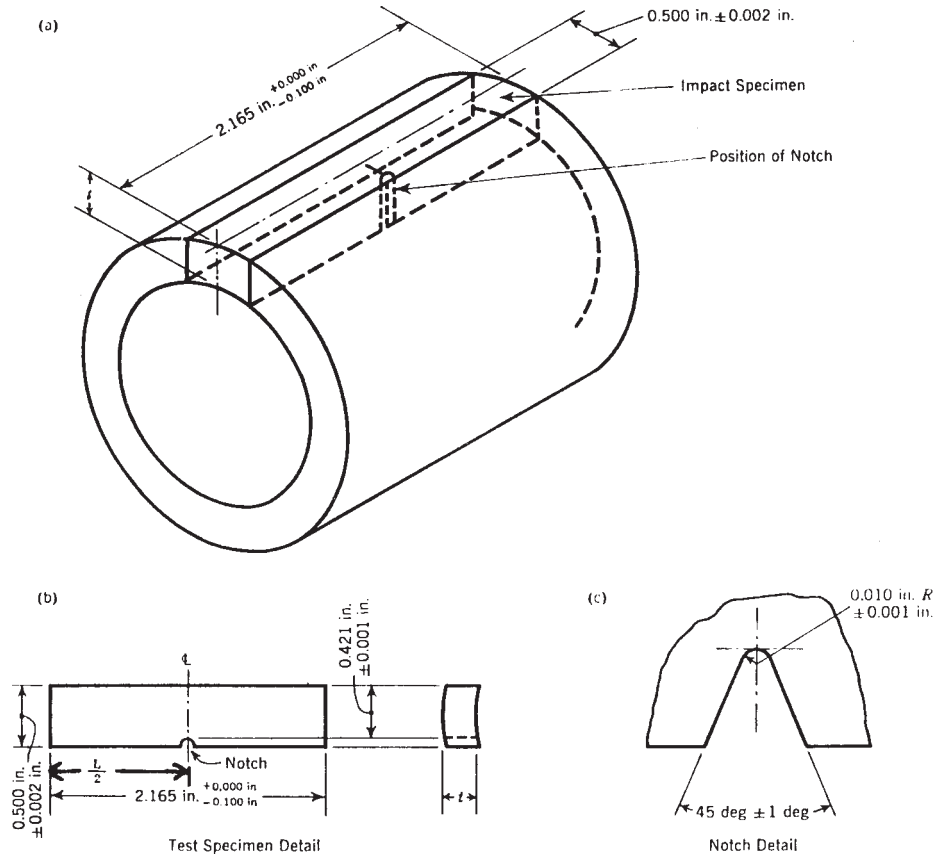

In Diagrams (a) and (b) the symbol  $t$  is for the pipe wall thickness.  
Permissible variations for  $\frac{1}{2}$  shall be  $\pm 0.040 \text{ in.}$

**FIG. 2 Impact Test Specimen for Ductile Iron Pipe and Tube**

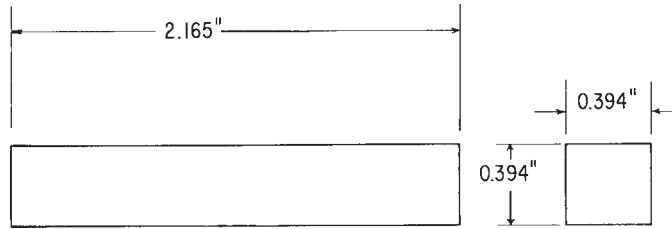

NOTE—Permissible variations shall be as follows:

Adjacent sides shall be at	$90^\circ \pm 10 \text{ min}$
Cross section dimensions	$\pm 0.001 \text{ in.}$
Length of specimen	$\pm 0, -0.100 \text{ in.}$

**FIG. 3 Unnotched Charpy Bar Impact Test Specimen**

ASTM International takes no position respecting the validity of any patent rights asserted in connection with any item mentioned in this standard. Users of this standard are expressly advised that determination of the validity of any such patent rights, and the risk of infringement of such rights, are entirely their own responsibility.

This standard is subject to revision at any time by the responsible technical committee and must be reviewed every five years and if not revised, either reapproved or withdrawn. Your comments are invited either for revision of this standard or for additional standards and should be addressed to ASTM International Headquarters. Your comments will receive careful consideration at a meeting of the responsible technical committee, which you may attend. If you feel that your comments have not received a fair hearing you should make your views known to the ASTM Committee on Standards, at the address shown below.

This standard is copyrighted by ASTM International, 100 Barr Harbor Drive, PO Box C700, West Conshohocken, PA 19428-2959, United States. Individual reprints (single or multiple copies) of this standard may be obtained by contacting ASTM at the above address or at 610-832-9585 (phone), 610-832-9555 (fax), or [service@astm.org](mailto:service@astm.org) (e-mail); or through the ASTM website ([www.astm.org](http://www.astm.org)).