



Standard Specification for Ferritic Ductile Iron Pressure-Retaining Castings for Use at Elevated Temperatures¹

This standard is issued under the fixed designation A 395/A 395M; the number immediately following the designation indicates the year of original adoption or, in the case of revision, the year of last revision. A number in parentheses indicates the year of last reapproval. A superscript epsilon (ϵ) indicates an editorial change since the last revision or reapproval.

This standard has been approved for use by agencies of the Department of Defense.

^{ε1} NOTE—Figures 4 and 5 were editorially corrected in March 2004.

1. Scope

1.1 This specification covers ductile iron castings for pressure-retaining parts for use at elevated temperatures. Castings of all grades are suitable for use up to 450°F. For temperatures above 450°F and up to 650°F, only Grade 60–40–18 castings are suitable (Note 1).

1.2 Valves, flanges, pipe fittings, pumps, and other piping components are generally manufactured in advance and supplied from stock by the manufacturer, jobber, or dealer.

1.3 For supplemental casting requirements Specification A 834 may be utilized.

1.4 The values stated in either inch-pound units or SI units are to be regarded separately as standard. Within the text, the SI units are shown in brackets. The values stated in each system are not exact equivalents; therefore, each system shall be used independently of the other. Combining values from the two systems may result in nonconformance to the specification.

NOTE 1—For service other than as specified in this section, reference should be made to Specification A 536 for Ductile Iron Castings.²

2. Referenced Documents

2.1 ASTM Standards:

A 247 Test Method for Evaluating the Microstructure of Graphite in Iron Castings²

A 370 Test Methods and Definitions for Mechanical Testing of Steel Products²

A 536 Specification for Ductile Iron Castings²

A 732/A732M Specification for Castings, Investment, Carbon and Low Alloy Steel for General Application, and Cobalt Alloy for High Strength at Elevated Temperatures²

A 834 Specification for Common Requirements for Iron Castings for General Industrial Use²

E 8 Test Methods for Tension Testing of Metallic Materials³
E 10 Test Method for Brinell Hardness of Metallic Materials³

E 186 Reference Radiographs for Heavy-Walled (2 to 4½ in. (51 to 114-mm)) Steel Castings⁴

E 280 Reference Radiographs for Heavy-Walled (4½ to 12-in. (114 to 305-mm)) Steel Castings⁴

E 446 Reference Radiographs for Steel Castings up to 2 in. (51 mm) in Thickness⁴

E 689 Reference Radiographs for Ductile Iron Castings⁴

E 1806 Practice for Sampling Steel and Iron for Determination of Chemical Composition⁵

F 1476 Specification for Performance of Gasketed Mechanical Couplings for Piping Applications⁶

F 1548 Specification for the Performance of Fittings for Use with Gasketed Mechanical Couplings used in Piping Applications⁶

2.2 *Manufacturer's Standardization Society of the Valve and Fittings Industry Standard:*

SP 25 Standard Marking Systems for Valves, Flanges, Pipe Fittings, and Unions⁷

3. Classification

3.1 Castings ordered to this specification are classified by grades based on mechanical property requirements, as listed in Table 1. See note following Table 1.

4. Ordering Information

4.1 Orders for material under this specification shall include the following applicable information:

4.1.1 Drawing, catalog number or part identifications,

4.1.1.1 For grade 65-45-15, drawing indicating critical area(s) of casting (see 7.2.2 and 7.3.2).

¹ This specification is under the jurisdiction of ASTM Committee A-4 on Iron Castings and is the direct responsibility of Subcommittee A04.02 on Malleable and Ductile Iron Castings.

Current edition approved Dec. 10, 1999. Published January 2000. Originally published as A 395 – 55 T. Last previous edition A 395 – 98.

² *Annual Book of ASTM Standards*, Vol 01.02.

³ *Annual Book of ASTM Standards*, Vol 03.01.

⁴ *Annual Book of ASTM Standards*, Vol 03.03.

⁵ *Annual Book of ASTM Standards*, Vol 03.06.

⁶ *Annual Book of ASTM Standards*, Vol 01.07.

⁷ Available from the Manufacturers' Standardization Society of the Valves and Fittings Industry, 1815 N. Fort Myer Drive, Arlington, VA 22209.

TABLE 1 Mechanical Property Requirements

Property	Grade 60-40-18	Grade 65-45-15
Tensile Strength Minimum, Psi [MPa]	60 000 [415]	65 000 [450]
Yield Strength Minimum, Psi [MPa]	40 000 [275]	45 000 [310]
Elongation in 2 in. Minimum, %	18	15
Hardness HB, 3000 Kgf Load	143-187	156-201

NOTE—If a grade is not specified in the ordering information, grade 60–40–18 will be supplied.

- 4.1.2 Quantity (weight or number of pieces),
- 4.1.3 ASTM designation and year of issue,
- 4.1.4 Grade (See Table 1), if a Grade is not specified, the manufacturer shall supply grade 60-40-18.
- 4.1.5 Heat treating requirements (see 5.2.1),
- 4.1.6 Pressure test requirements (see 7.4.3),
- 4.1.7 Test samples from castings (see 11.1.1 and 12.1.1),
- 4.1.8 Test coupons size (see 11.2),
- 4.1.9 Metallographic option (see 12.1.1),
- 4.1.10 Place of inspection (see 16.1),
- 4.1.11 Certification requirements (see 17.1),
- 4.1.12 Identification marking (see 18.2), and
- 4.1.13 Supplemental Requirements (see 1.4, 7.4.2, S1 and S2).

5. Materials and Manufacture

5.1 The melting method and the nodularizing practice shall be optional with the foundry.

5.2 Except as provided in 5.2.1, all castings Grade 60-40-18 shall be given a ferritizing heat treatment that produces essentially a ferritic structure that contains no massive carbides.

5.2.1 When specified in the purchase order, Grade 60-40-18 castings may be provided in an as cast condition provided they comply with the requirements of 7.1 and 7.2.1.

5.2.2 Castings supplied in accordance with 5.2.1 may be stress relieved by agreement between the manufacturer and purchaser.

5.3 Castings Grade 65-45-15 may be provided in as cast condition or heat treated, provided they comply with the requirements of 7.1, 7.2.2 and 7.3.2.

6. Chemical Requirements

6.1 The casting shall conform to the following requirements for chemical composition (Note 2):

Total carbon, min, %	3.00
Silicon, max, %	2.50
Phosphorus, max, %	0.08

6.1.1 The chemical analysis for total carbon shall be made on chilled cast pencil type specimens or from thin wafers approximately $\frac{1}{32}$ in. [0.8 mm] thick cut from test coupons. Drillings are not reliable because of the probable loss of graphite.

6.1.2 For each reduction of 0.01 % below the maximum specified phosphorus content, an increase of 0.08 % silicon above the specified maximum will be permitted up to a maximum of 2.75 %.

NOTE 2—Silicon contents above 2.75 %, or phosphorus contents above 0.08 % have a tendency to lower the impact resistance of the material. If the carbon content is below 3.00 %, excess cementite may form during

cooling and if this is not removed during heat treatment, the impact resistance of the material may be lowered.

7. Requirements

7.1 Tensile Properties:

7.1.1 The ductile iron as represented by the test specimens shall conform to the mechanical property requirements in Table 1.

7.2 Hardness:

7.2.1 For Grade 60–40–18 the hardness of the castings and test specimens shall be within the limits in Table 1.

7.2.2 For Grade 65–45–15 the hardness of test specimen and the critical area(s) of the casting, as identified on the casting drawing, shall be within the limits in Table 1. If the grade 65–45–15 casting drawing does not have critical area(s) of the casting identified, all areas of the casting shall be within the hardness limits in Table 1.

7.3 Microstructure:

7.3.1 For Grade 60-40-18 the microstructure of the separately cast test coupon or the casting shall be essentially ferritic and contain no massive carbides, and have a minimum of 90 % Type I and Type II Graphite as in Fig. 1 or Plate I of Test Method A 247.

7.3.2 For Grade 60-45-15 the microstructure of the critical areas of the casting, as identified on the casting drawing, shall be 45 % pearlitic, maximum, contain no massive carbides, and have a minimum 90 % Type I and Type II Graphite as in Fig. 1 or Plate I of Test Method A 247.

7.4 Pressure Test Requirements:

7.4.1 Each pressure retaining Grade 60-40-18 casting shall be tested after machining to the test pressure specified by the applicable standard of ANSI, ASME Boiler and Pressure Vessel Code, or other pertinent code, and shall show no leaks.

7.4.2 Castings, Grade 65-45-15 manufactured under this specification shall be capable of passing hydrostatic test(s) compatible with the rating of the finished cast component. Such tests shall be conducted by the casting manufacturer only when supplementary requirement S2 is specified.

7.4.3 Castings Grade 60-40-18, ordered under this specification not covered by ANSI standards and ASME Pressure Vessel Code, and castings for special service applications, shall be tested to such pressures as may be agreed upon by the manufacturer and the purchaser.

7.4.4 For castings Grade 60-40-18, it is realized that the foundry may be unable to perform the hydrostatic test prior to shipment, or that the purchaser may wish to defer testing until additional work or machining has been performed on the casting. Castings ordered in the rough state for final machining by the purchaser may be tested hydrostatically prior to shipment by the manufacturer at pressures to be agreed upon with the purchaser. However, the foundry is responsible for the satisfactory performance of the castings under the final hydrostatic test.

8. Workmanship and Finish

8.1 The surface of the casting shall be examined visually and shall be free from adhering sand, scale, cracks, and hot tears. Any other surface discontinuities shall meet visual acceptance standards specified in the order.

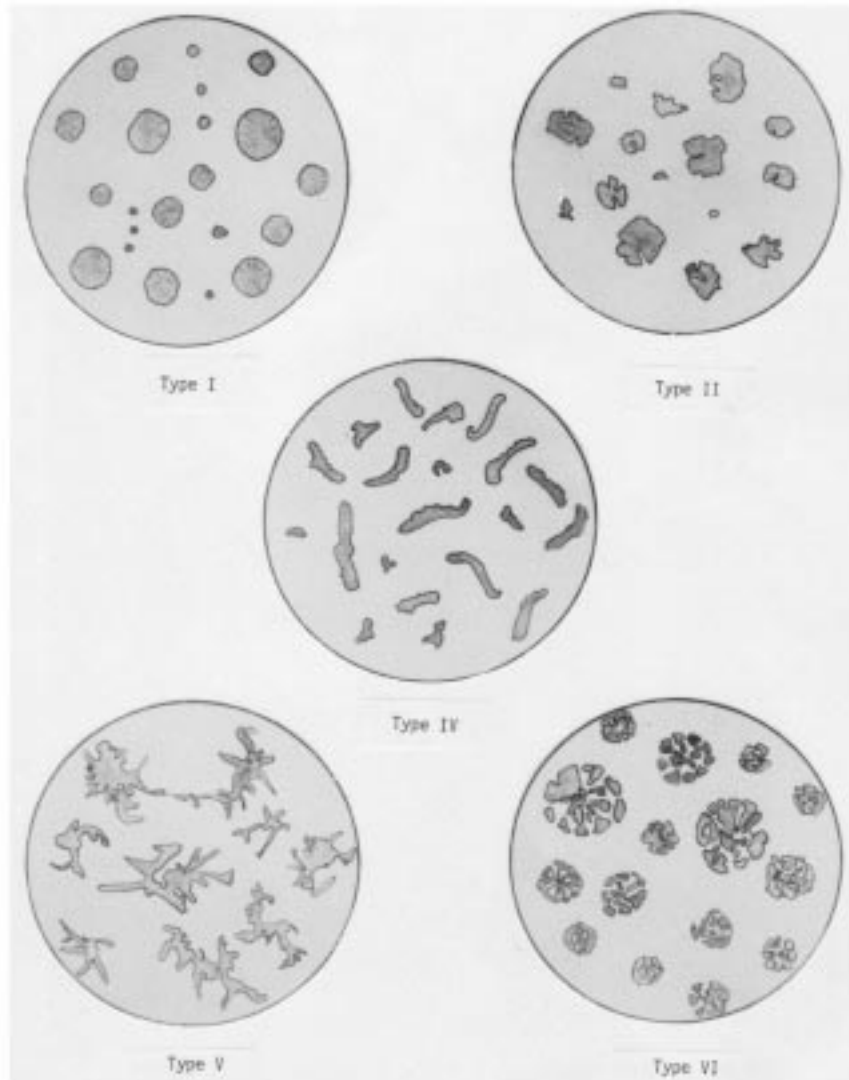

NOTE—Graphite types are identical with Plate 1 of Method A 247 and are so identified.
FIG. 1 Suggested Classification of Graphite Form in Ductile Cast Iron

9. Repair

9.1 Castings for valves, flanges, pipe fittings, pumps, and other piping components ordered under applicable ANSI standards shall not be repaired by plugging, welding, brazing, or impregnation.

9.2 Castings Grade 60-40-18 not covered in 9.1 which leak on hydrostatic tests may be repaired by plugging, provided the following requirements are met:

9.2.1 No welding or brazing is permitted.

9.2.2 The diameter of the plug shall not exceed the diameter of a standard 2 in. [ISO R2] pipe plug.

9.2.3 The plugs, where practical, shall conform in all dimensions to the standard ISO $\frac{3}{8}$ plugs. In addition, they shall have full thread engagement corresponding to the thickness in the repaired section. Where a tapered plug is impractical because of the excess wall thickness in terms of plug diameter and coincident thread engagement, other types of plugs may be used provided both full engagement and effective

sealing against pressure are obtained. Where possible, the ends of the plug should be ground smooth after installation to conform to the inside and outside contours of the wall of the pressure vessel or pressure part.

9.2.4 The material from which the plug is manufactured shall conform in all respects to the materials specifications which apply to the pressure vessel or pressure part.

9.2.5 The area adjacent to the drilled hole shall be examined by radiography, and shall meet the Level 3 acceptance requirements of Reference Radiographs E 689 and supporting Reference Radiographs E 446, E 186, or E 280 as applicable and defined in accordance with Reference Radiographs E 689.

9.2.6 The thickness of any repaired section in relation to the size of the plug used shall not be less than that given in Table 2.

9.2.7 The minimum radius of repaired sections of cylinders or cones in relation to the size of plug used shall not be less than that given in Table 3.

TABLE 2 Minimum Thickness of Repaired Sections

Iron Pipe Size Plug, in.	Minimum Thickness Repaired Section, in. [mm]
1/8	1 1/32 [8]
1/4	7/16 [10]
3/8	1/2 [13]
1/2	2 1/32 [17]
3/4	3/4 [19]
1	1 3/16 [21]
1 1/4	7/8 [23]
1 1/2	1 5/16 [24]
2	1 [26]

TABLE 3 Minimum Radius of Repaired Sections

Iron Pipe Size Plug, in.	Minimum Radius of Cylinder or Cone, in. [mm]
1/8	3/16 [15]
1/4	1 1/16 [18]
3/8	1 1/16 [28]
1/2	1 1/4 [32]
3/4	2 [52]
1	2 1/2 [64]
1 1/4	4 [104]
1 1/2	5 1/4 [136]
2	8 1/8 [208]

9.2.8 A repaired area may consist of a maximum of three plugs with a spacing such that the ligaments between adjacent plugs shall not be less than listed in Table 4. Other defective areas may also be repaired by plugging provided the minimum ligament between plugs in adjacent areas is not less than twice the distance from the nearest plug, the values for which are listed in Table 4.

9.3 Surface imperfections in castings Grade 60-40-18 other than valves, flanges, pipe fittings, pumps, and other piping components may be repaired by plugging provided the depth of the plug is not greater than 20 % of the thickness of the casting section and the diameter of the plug is not greater than its length. Repair of surface defects may not be done on pressure containing portions of castings. The plug need not be threaded. The conditions of 9.2.1 and 9.2.4 shall also be satisfied.

10. Sampling

10.1 A lot shall consist of one of the following:

10.1.1 All the metal from a single heating in a batch—type melting furnace.

TABLE 4 Minimum Ligament Between Plugs^{A,B}

Nominal Plug Diameter, in.	Minimum Ligament Between Plugs, in. [mm]			
	1/8, 1/4, 3/8	1/2, 3/4	1, 1 1/4	1 1/2, 2
1/8, 1/4, 3/8	2 5/8 [67]	4 1/8 [105]	6 5/8 [169]	9 1/2 [242]
1/2, 3/4	4 1/8 [105]	4 1/8 [105]	6 5/8 [169]	9 1/2 [242]
1, 1 1/4	6 5/8 [169]	6 5/8 [169]	6 5/8 [169]	9 1/2 [242]
1 1/2, 2	9 1/2 [242]	9 1/2 [242]	9 1/2 [242]	9 1/2 [242]

^ABased on efficiency of 80 %.

^BExample: Assume three plugs are required for repair, one 1/8 in., one 3/8 in., and one 1 1/2 in. The minimum distance permitted is as follows:

- Ligament distance between 1/8 and 3/8-in. plugs is 2 5/8 in. [67mm].
- Ligament distance between 1/8 and 1 1/2-in. plugs is 9 1/2 in. [242 mm].
- Ligament distance between 3/8 and 1 1/2-in. plugs is 9 1/2 in. [242 mm].

10.1.2 All the metal poured from two or more batch-type melting furnaces into a single ladle or a single casting.

10.1.3 All the metal poured from a continuous melting furnace for a given period of time between changes in charge, processing conditions, or aim-for chemistry, or 8 h, whichever is the shorter period.

11. Test Coupon

11.1 The separately cast test coupons poured from the same lot as the castings they represent from which the tension test specimen is machined shall be cast to the size and shape shown in Fig. 2, Fig. 3, or Fig. 4. Cast coupons shall be identified with the castings they represent. Sectioning procedure for removing test specimens from Y-blocks is shown in Fig. 5.

11.1.1 Test samples may be removed from castings at locations designated on a drawing or as agreed to by manufacturer and purchaser.

11.1.2 Test bars removed from castings shall conform to Fig. 6. The testing diameter shall be 1/2 in. [12.5 mm] if possible. Smaller diameters shall be utilized if necessary.

11.2 The test coupon size shall be as mutually agreed upon between the manufacturer and purchaser. In the absence of agreement, it shall be the option of the manufacturer.

11.3 The test coupons shall be cast in molds made of suitable core sand having a minimum wall thickness of 1 1/2 in. [38 mm] for the 1/2 in. [12.5 mm], 1 in. [25 mm] sizes, and 3 in. [75 mm] for the 3 in. [75 mm] size. The coupons shall be left in the mold until they have changed to a black color (approximately 900°F [480°C] or less). The keel block as shown in Fig. 2 or the modified keel block produced from the mold shown in Fig. 4 may be substituted for the 1 in. [25 mm] block shown in Fig. 3.

11.4 When investment castings are made to this specification, the manufacturer may use test specimens cast to size incorporated in the mold with the castings or separately cast to size using the same type of mold and the same thermal

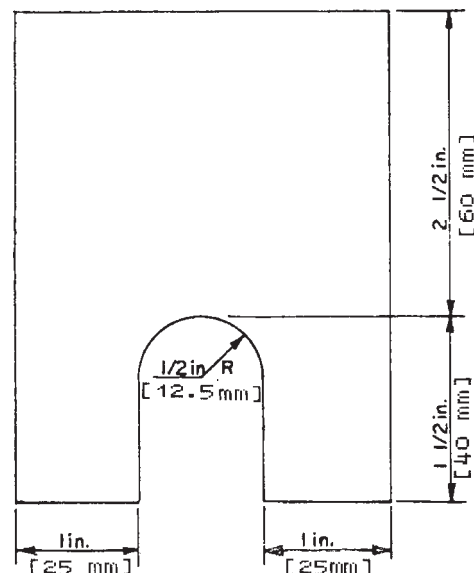

NOTE—The length of the keel block shall be 6 in. [152 mm]

FIG. 2 Keel Block for Test Coupons

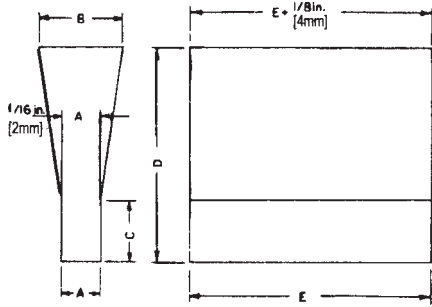

Dimensions	"Y" Block Size		
	For Castings of Thickness Less Than 1/2 in. [13 mm]	For Castings of Thickness 1/2 in. [13 mm] to 1 1/2 in. [38 mm]	For Castings of Thickness of 1 1/2 in. [38 mm] and Over
	in. [mm]	in. [mm]	in. [mm]
A	1/2 [13]	1 [25]	3 [75]
B	1 5/8 [40]	2 1/8 [55]	5 [125]
C	2 [50]	3 [75]	4 [100]
D	4 [100]	6 [150]	8 [200]
E	7 [175] approx	7 [175] approx	7 [175] approx

FIG. 3 Y-Blocks for Test Coupons

conditions that are used to produce the castings. These test specimens shall be made to the dimensions shown in Fig. 1 of Specification A 732 or Fig. 5 and Fig. 6 of Test Methods and Definitions A 370.

11.5 The manufacturer shall cast a sufficient number of test coupons to provide for each ferritizing anneal. The test coupons shall be heat treated with the castings they represent. Sectioning of the test coupons prior to heat treating is not permitted.

11.6 The metallographic examination shall be made on a test lug from the test coupon shown in Fig. 7 or from a casting; or from a representative test coupon poured with the casting(s). The test coupon shall represent the metal treated with the nodularizing agent.

12. Number of Tests and Retests

12.1 One tension test shall be made from sections cut from the test coupons (Fig. 5) required by Section 11.

12.1.1 Unless otherwise stated in the contract or order for castings, a metallographic examination may be substituted for the tension test when separately cast test coupons are used. When the microstructure option is used, a minimum of one tension test is required from each day's melt and for each heat treatment (see 12.2).

12.2 If any tension test specimen shows obvious defects, another from the same coupon, or from another coupon/or representing the same metal and the same anneal charge, may be tested. If an apparently sound test specimen fails to conform to this specification, castings may be re-annealed, if required, and two retests made. If either retest fails to conform to this specification, the castings they represent shall be rejected.

13. Tension Test Specimen Preparation

13.1 The standard machined 1/2 in. [12.5 mm] round tension test specimen with 2 in. [50 mm] gauge length as shown in Fig.

6 shall be used except where the 1/2 in. [12.5 mm] Y-block test coupon is required. In this case, either of the small size specimens, 0.375 or 0.250 in. [9 or 6.5 mm] round as shown in Fig. 6 shall be used.

14. Test Methods

14.1 Chemical analysis shall be made in accordance with Test Method E 1806.

14.2 The yield strength shall be determined in accordance with Test Methods E 8 using one of the following methods:

14.2.1 The 0.2 % off-set method, or

14.2.2 Extension under load method where the yield strength may be determined as the stress producing an elongation under load of 0.375 %; that is, 0.0075 in. [0.19 mm] in a gauge length of 2 in. [50 mm].

14.3 The hardness of the ductile iron as represented by the test specimens and castings shall be determined in accordance with Test Method E 10.

14.4 The percentage of each graphite type shall be determined by manual counting, semi-automatic or automatic image analysis methods. The sum of all graphite types shall total to 100 %.

15. Records

15.1 Records of the chemical composition, mechanical properties, and metallographic examination, when applicable, shall be systematically made and maintained.

16. Inspection

16.1 Unless otherwise specified in the contract or purchase order, the manufacturer shall be responsible for carrying out all the tests and inspection required by this specification.

16.2 The inspector representing the purchaser shall have entry at all time, while work on the contract of the purchaser is being performed, to all parts of the manufacturer's works which concern the manufacturer of the material ordered. The manufacturer shall afford the inspector all reasonable facilities to satisfy him that the material is being furnished in accordance with these specifications. Unless otherwise specified, all tests and inspection shall be made at the place of manufacture or by an approved independent laboratory prior to shipment, and shall be so conducted as not to interfere unnecessarily with the operation of the works.

17. Certification

17.1 When agreed upon in writing by the purchaser and the supplier, a certification shall be made on the basis of acceptance of the material. This shall consist of a copy of the manufacturer's test report or a statement by the supplier accompanied by a copy of the test results, that the material has been sampled, tested, and inspected in accordance with the provisions of this specification. Each certification so furnished shall be signed by an authorized agent of the supplier or manufacturer.

18. Product Marking

18.1 Castings for valves, flanges, pipe fittings, and unions shall be marked for material identification in accordance with

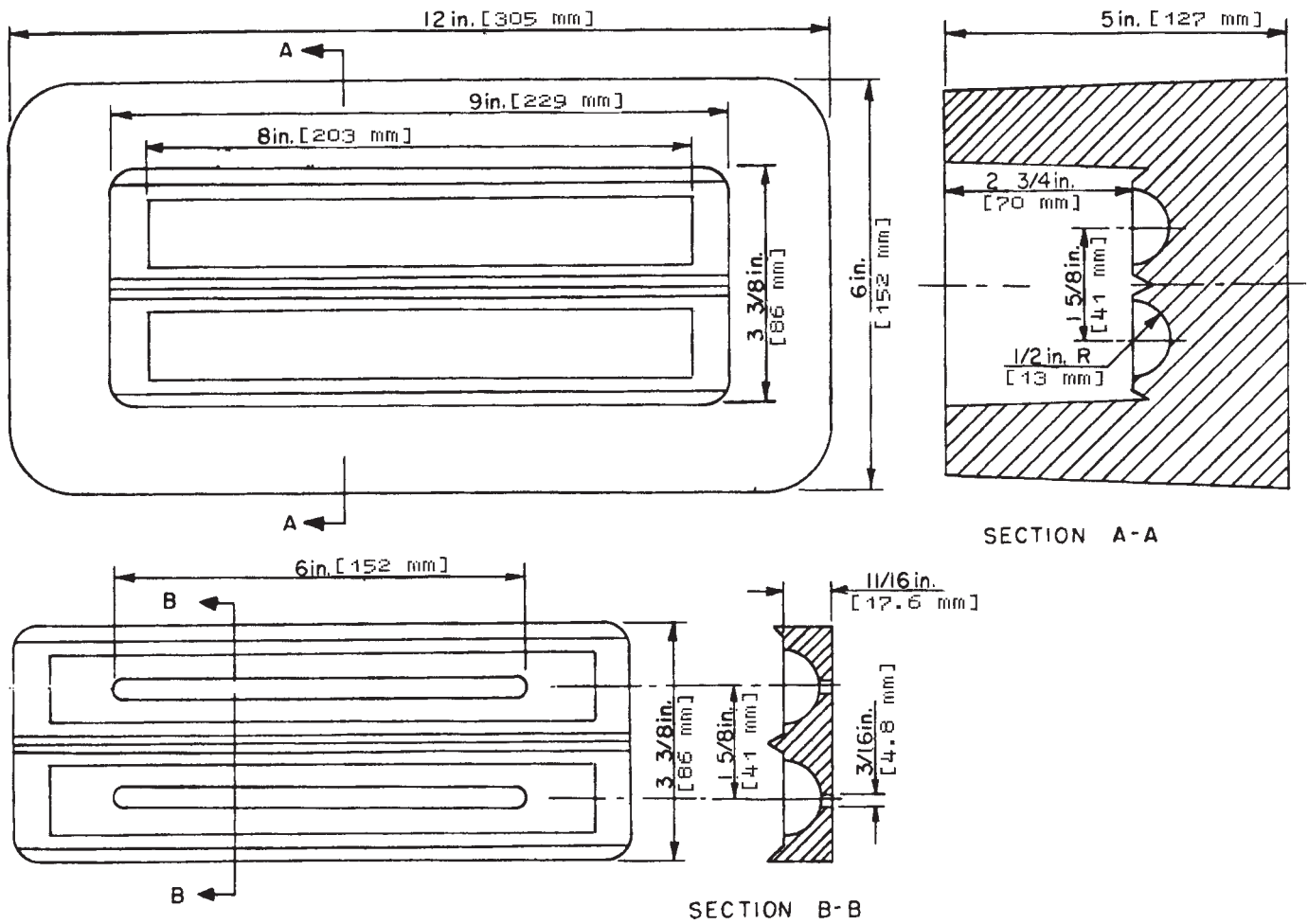

FIG. 4 Mold for Modified Keel Block

the Standard Marking System for Valves, Flanges, Pipe Fittings, and Unions, SP-25. Castings for gasketed mechanical couplings and fittings may be marked in accordance with F 1476 or F 1548 respectively.

18.2 Castings, other than valves, flanges, pipe fittings, and unions shall be identified subject to agreement by the manufacturer and the purchaser.

18.3 Marking shall be in such a position as not to injure the usefulness of the castings.

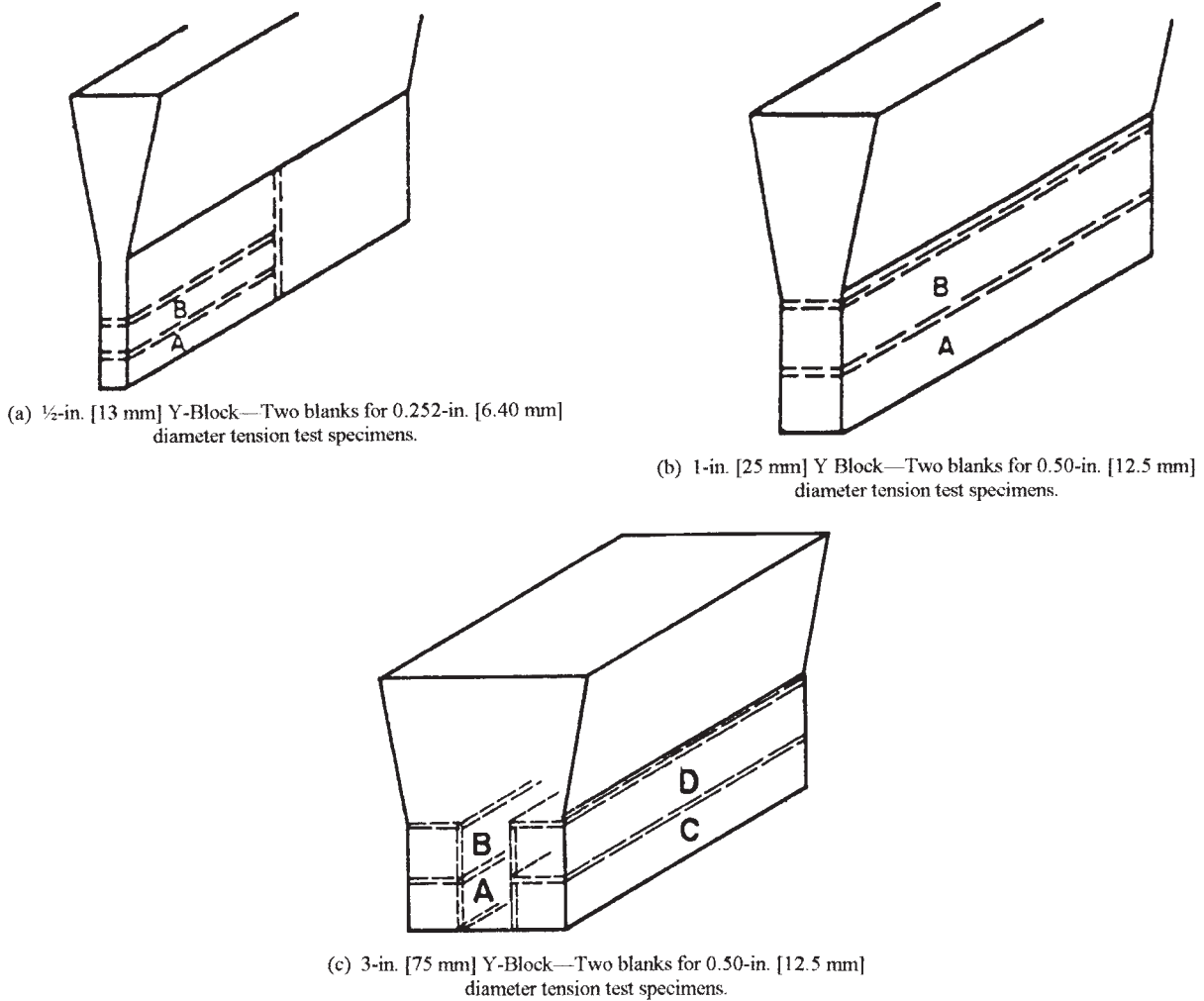
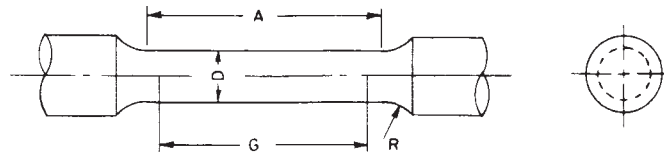

FIG. 5 Sectioning Procedure for Y-Blocks



NOTE 1—The reduced section may have a gradual taper from the ends toward the center, with the ends not more than 0.005 in. [0.13 mm] larger in diameter than the center on the standard specimen, and not more than 0.003 in. [0.076 mm] larger in diameter than the center on the small size specimens.

NOTE 2—If desired, on the small size specimens the length of the reduced section may be increased to accommodate an extensometer. However, reference marks for measurement of elongation should nevertheless be spaced at the indicated gage length.

NOTE 3—The gage length and fillets shall be as shown, but the ends may be of any form to fit the holders of the testing machine in such a way that the load shall be axial. If the ends are to be held in grips, it is desirable to make the length of the grip section great enough to allow the specimen to extend into the grips a distance equal to two thirds or more of the length of the grips.

Dimensions	Standard Specimen, in. [mm]	Small Size Specimens Proportionate to Standard, in. [mm]	
	1/2 [12.5] Round	0.350 [9] Round	0.250 [6.5] Round
G—Gage length	2.000 ± 0.005 [50 ± 0.13]	1.4 ± 0.005 [35 ± 0.13]	1.0 ± 0.005 [25 ± 0.13]
D—Diameter (Note 1)	0.500 ± 0.010 [12.5 ± 0.25]	0.350 ± 0.007 [9 ± 0.18]	0.250 ± 0.005 [6.5 ± 0.13]
R—Radius of fillet	3/8 [9.5], min	3/8 [9.5], min	1/4 [6.5], min
A—Length of reduced section (Note 2)	2 1/4 [58], min	1 3/4 [45], min	1 1/4 [32], min

FIG. 6 Standard 1/2-in. [12.5-mm] Round Tension Test Specimen with 2-in. [50.0-mm] Gage Length and Examples of Small Size Specimens Proportionate to the Standard Specimen

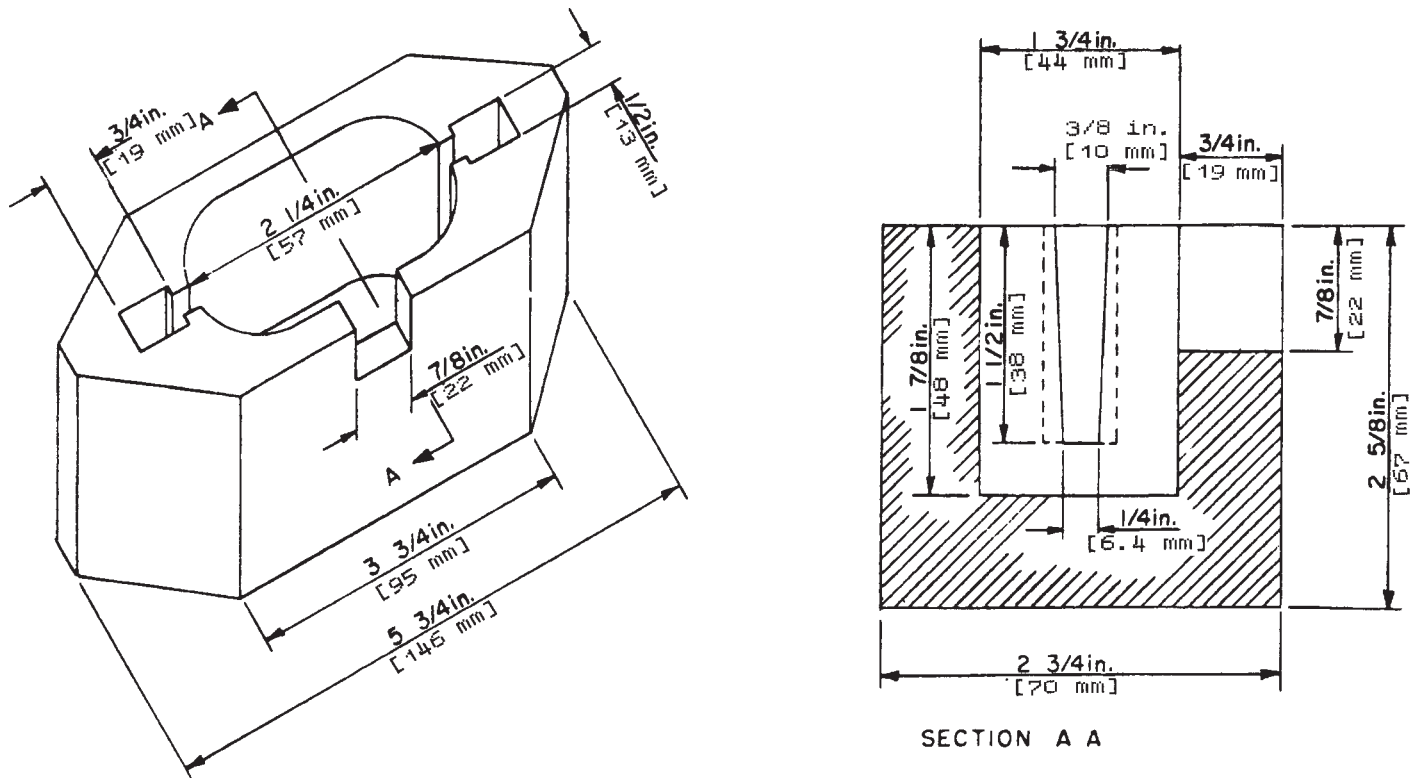

FIG. 7 Test Coupon for Microscopical Examination of Ductile Iron

19. Keywords

19.1 casting; ductile iron; mechanical properties; pressure-retaining; pressure test; tensile strength; tension testing; yield strength

SUPPLEMENTARY REQUIREMENTS

The following supplementary requirement shall not apply unless specified in the purchase order.

S1. For Castings Grade 60-40-18, a microstructure test lug is to be cast attached to the casting at the location designated on the casting drawing. The microstructure of the test lug shall be essentially ferritic and contain no massive carbides.

S2. Pressure Test, Casting Grade 65-45-15

S2.1 A hydrostatic test at a pressure agreed upon by the manufacturer and the purchaser shall be applied by the manufacturer.

ASTM International takes no position respecting the validity of any patent rights asserted in connection with any item mentioned in this standard. Users of this standard are expressly advised that determination of the validity of any such patent rights, and the risk of infringement of such rights, are entirely their own responsibility.

This standard is subject to revision at any time by the responsible technical committee and must be reviewed every five years and if not revised, either reapproved or withdrawn. Your comments are invited either for revision of this standard or for additional standards and should be addressed to ASTM International Headquarters. Your comments will receive careful consideration at a meeting of the responsible technical committee, which you may attend. If you feel that your comments have not received a fair hearing you should make your views known to the ASTM Committee on Standards, at the address shown below.

This standard is copyrighted by ASTM International, 100 Barr Harbor Drive, PO Box C700, West Conshohocken, PA 19428-2959, United States. Individual reprints (single or multiple copies) of this standard may be obtained by contacting ASTM at the above address or at 610-832-9585 (phone), 610-832-9555 (fax), or service@astm.org (e-mail); or through the ASTM website (www.astm.org).