



## Standard Specification for Austenitic Ductile Iron Castings<sup>1</sup>

This standard is issued under the fixed designation A 439; the number immediately following the designation indicates the year of original adoption or, in the case of revision, the year of last revision. A number in parentheses indicates the year of last reapproval. A superscript epsilon ( $\epsilon$ ) indicates an editorial change since the last revision or reapproval.

### 1. Scope

1.1 This specification covers austenitic ductile iron castings which are used primarily for their resistance to heat, corrosion, and wear, and for other special purposes.

1.2 Austenitic ductile iron, also known as austenitic nodular iron or austenitic spheroidal iron, is characterized by having its graphite substantially in a spheroidal form and substantially free of flake graphite. It contains some carbides and sufficient alloy content to produce an austenitic structure.

1.3 The values stated in inch-pound units are to be regarded as the standard. The values given in parentheses are for information only.

### 2. Referenced Documents

#### 2.1 ASTM Standards:

A 370 Test Methods and Definitions for Mechanical Testing of Steel Products<sup>2</sup>

A 732/A 732M Specification for Castings, Investment, Carbon and Low Alloy Steel for General Application, and Cobalt Alloy for High Strength at Elevated Temperatures<sup>3</sup>

E 8 Test Methods for Tension Testing of Metallic Materials<sup>4</sup>

E 30 Test Methods for Chemical Analysis of Steel, Cast Iron, Open-Hearth Iron, and Wrought Iron<sup>5</sup>

E 59 Practice for Sampling Steel and Iron for Determination of Chemical Composition<sup>5</sup>

E 351 Test Methods for Chemical Analysis of Cast Iron—All Types<sup>5</sup>

### 3. Ordering Information

3.1 Orders for material to this specification shall include the following information:

3.1.1 ASTM designation,

3.1.2 Type of austenitic ductile iron required (see 6.1),

3.1.3 Heat treatment required (see 4.2 through 4.4),

3.1.4 If repair of castings is permitted (see 4.5),

3.1.5 Size and number of test bars required (see 9.1 through 9.4 and 10.1),

3.1.6 Special tests, if required (see 12.1),

3.1.7 Certification, if required (see 14.1), and

3.1.8 Different preparation for delivery requirements, if needed (see 15.1).

### 4. Manufacture

4.1 Melting may be done in any furnaces that produce castings meeting the chemical and mechanical requirements outlined in this specification. These include cupolas, air furnaces, electric furnaces, crucible furnaces, etc.

4.2 By agreement between the manufacturer and the purchaser, the castings may be stress relieved by heating to 1150 to 1200°F (621 to 650°C) for not less than 1 h nor more than 2 h per inch of thickness in the thickest section. Heating and cooling shall be uniform and shall not be more than 400°F (222°C)/h for castings less than 1 in. (25.4 mm) in maximum thickness, nor more than 400°F (222°C) divided by the maximum section thickness in inches for thicker castings. During the cooling cycle, castings may be cooled in still air after the temperature has dropped to 600°F (315°C).

4.3 Whenever dimensional changes in high-temperature service are a problem, by agreement between the manufacturer and the purchaser, the castings may be stabilized by heating at 1600°F (870°C) for 1 h per inch of section, with a minimum of 1 h. Otherwise, the austenite which is super-saturated with respect to carbon may reject carbon during service and produce dimensional changes.

4.4 By agreement between the manufacturer and the purchaser, castings with chilled edges or excessive carbides may be annealed at 1750 to 1900°F (955 to 1040°C) for ½ to 5 h followed by uniform cooling, preferably in still air.

4.5 Repair by welding, plugging, or other approved methods may be done only with written permission from the purchaser.

### 5. Magnetic Properties

5.1 In the event that nonmagnetic castings are specified, the magnetic permeability test shall be used. The maximum magnetic permeability value shall be agreed upon between the manufacturer and the purchaser.

NOTE 1—A convenient shop test for differentiating the various types of austenitic ductile iron is based on the fact that a ground face of either the test bar or the castings of Types D-2 and D-2C will not attract a small steel

<sup>1</sup> This specification is under the jurisdiction of ASTM Committee A-4 on Iron Castings and is the direct responsibility of Subcommittee A04.02 on Malleable and Ductile Iron Castings.

Current edition approved July 29, 1983. Published September 1983. Originally published as A439-60T. Last previous edition A439-82.

<sup>2</sup> *Annual Book of ASTM Standards*, Vol 01.03.

<sup>3</sup> *Annual Book of ASTM Standards*, Vol 01.02.

<sup>4</sup> *Annual Book of ASTM Standards*, Vol 03.01.

<sup>5</sup> *Annual Book of ASTM Standards*, Vol 03.05.

horseshoe-type magnet which is normally attracted to steel (Alnico magnet should not be used). Types D-3, D-3A, D-5, and D-5B are attracted, and types D-2B and D-4 may be slightly attracted. This nonmagnetic test is a convenient qualitative test only for Types D-2 and D-2C and shall not be used as a basis for acceptance.

## 6. Chemical Requirements

6.1 Many combinations of alloys can be used to obtain an austenitic ductile iron. This specification includes nine general types defined by the composition limits in Table 1.

6.2 Samples taken from test coupons, broken test specimens, or castings shall conform to the requirements as to chemical composition prescribed in Table 1. Sampling shall be conducted in accordance with Method E 59 and chemical analyses in accordance with Test Methods E 351 and Methods E 30. Methods E 30 should only be used for analyzing those elements for which specific coverage is not provided for in Test Methods E 351.

6.3 Spectrometric techniques may also be used for analysis, but should a dispute arise concerning chemical composition, Test Methods E 351 and Methods E 30 shall be used for referee methods.

6.4 The chemical analysis for total carbon shall be made on either chilled cast pencil-type specimens or thin wafers approximately 1/32 in. (0.8 mm) thick cut from test coupons. Drillings shall not be used because of attendant loss of graphite.

## 7. Mechanical Requirements

7.1 Test specimens of austenitic ductile iron made according to this specification shall meet the test requirements prescribed in Table 2.

7.2 The yield strength shall be determined in accordance with Test Methods E 8, using one of the following procedures: the 0.2 % off-set method or the extension under load method may be used, by agreement between the purchaser and the manufacturer.

## 8. Workmanship, Finish, and Appearance

8.1 The castings shall conform substantially to the dimensions on the drawings furnished by the purchaser, or if no drawing has been provided, to the dimensions predicated by the pattern supplied by the purchaser. The castings shall be free of injurious defects. Surfaces of the castings shall be free of burnt-on sand and shall be reasonably smooth. Runners, risers, fins, and other useless cast-on pieces shall be removed. In other respects, the castings shall conform to whatever points may be specifically agreed upon between the manufacturer and the purchaser.

## 9. Test Bars

9.1 The standard test bars shall be the 1-in. (25.4-mm) “Y” block and 1-in. (25.4-mm) keel block as shown in Fig. 1 and Fig. 2, respectively. A modified keel block cast from the mold shown in Fig. 3 may be substituted for the 1-in. (25.4-mm) “Y” block or the 1-in. keel block.

9.2 Whenever the section size of the castings is considerably less or greater than 1 in. (25.4 mm) and by agreement between the purchaser and the manufacturer, the 1/2-in. (12.7-mm) or 3-in. (76.2-mm) “Y” blocks shown in Fig. 1 may be used.

9.3 The test bars shall be cast in open molds made of a suitable core sand with a minimum of 1/2 in. (38.1 mm) of sand on all sides and bottom of the 1/2 and 1-in. (12.7 and 25.4-mm) test bars and 3 in. (76.2 mm) of sand for the 3-in. (76.2-mm) test bar.

9.4 When investment castings are made to this specification, the manufacturer may use test specimens cast to size incorporated in the mold with the castings, or separately cast to size using the same type of mold and the same thermal conditions that are used to produce the castings. These test specimens shall be made to the dimensions shown in Fig. 1 of Specification A 732 or Fig. 4 and Fig. 3 of Test Methods and Definitions A 370.

9.5 It is recommended that test bars be poured immediately after the castings and from the same ladle of metal. Test bars shall be left in the mold until they have cooled to a black appearance. If castings are to be heat treated, test bars shall be included in the same furnace load.

## 10. Number of Tests

10.1 Test bars shall be poured from each ladle treated with nodularizing agent, unless otherwise specified.

10.2 The number of test bars cast shall be agreed upon by the manufacturer and the purchaser.

10.3 One tension test shall be made from sections cut from the test bars as shown in Fig. 4. If any tension test shows obvious foundry or machining defects, another specimen may be cut from the same test bar or from another test bar representing the same metal. If the retest specimen fails to conform to this specification, the castings they represent shall be rejected.

## 11. Tension Test Specimens

11.1 The standard round tension test specimen with 2-in. or 50-mm gage length shown in Fig. 5 shall be used, except when the 1/2-in. (12.7-mm) “Y” block is used or when specimens are cut from castings under 3/4-in. (19.0-mm) thickness. In these

**TABLE 1 Chemical Requirements**

Element	Type								
	D-2 <sup>A</sup>	D-2B	D-2C	D-3 <sup>A</sup>	D-3A	D-4	D-5	D-5B	D-5S
Composition, %									
Total carbon, max	3.00	3.00	2.90	2.60	2.60	2.60	2.40	2.40	2.30
Silicon	1.50–3.00	1.50–3.00	1.00–3.00	1.00–2.80	1.00–2.80	5.00–6.00	1.00–2.80	1.00–2.80	4.90–5.50
Manganese	0.70–1.25	0.70–1.25	1.80–2.40	1.00 max <sup>B</sup>	1.00 max <sup>B</sup>	1.00 max <sup>B</sup>	1.00 max <sup>B</sup>	1.00 max <sup>B</sup>	1.00 max
Phosphorus, max	0.08	0.08	0.08	0.08	0.08	0.08	0.08	0.08	0.08
Nickel	18.00–22.00	18.00–22.00	21.00–24.00	28.00–32.00	28.00–32.00	28.00–32.00	34.00–36.00	34.00–36.00	34.00–37.00
Chromium	1.75–2.75	2.75–4.00	0.50 max <sup>B</sup>	2.50–3.50	1.00–1.50	4.50–5.50	0.10 max	2.00–3.00	1.75–2.25

<sup>A</sup>Additions of 0.7 to 1.0 % of molybdenum will increase the mechanical properties above 800°F (425°C).

<sup>B</sup>Not intentionally added.

**TABLE 2 Mechanical Requirements**

Element	Type								
	D-2	D-2B	D-2C	D-3	D-3A	D-4	D-5	D-5B	D-5S
	Properties								
Tensile strength, min, ksi (MPa)	58 (400)	58 (400)	58 (400)	55 (379)	55 (379)	60 (414)	55 (379)	55 (379)	65 (449)
Yield strength (0.2 percent offset), min, ksi (MPa)	30 (207)	30 (207)	28 (193)	30 (207)	30 (207)	...	30 (207)	30 (207)	30 (207)
Elongation in 2 in. or 50 mm, min, %	8.0	7.0	20.0	6.0	10.0	...	20.0	6.0	10
Brinell hardness (3000 kg)	139–202	148–211	121–171	139–202	131–193	202–273	131–185	139–193	131–193

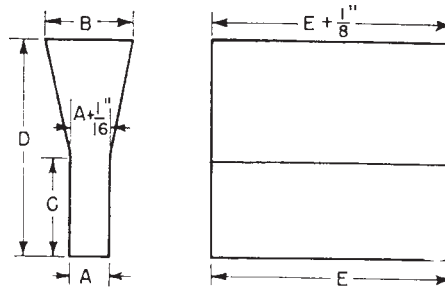

Dimensions	"Y" Block Size							
	For Castings of Thickness Less than 1/2 in. (13 mm)		For Castings of Thickness 1/2 in. (13 mm) to 1 1/2 in. (38 mm)		For Castings of Thickness 1 1/2 in. (38 mm) and Over			
	in.	mm	in.	mm	in.	mm		
A	1/2	13	1	25	3	75		
B	1 5/8	40	2 1/8	54	5	125		
C	2	50	3	75	4	100		
D	4	100	6	150	8	200		
E	7	175	7	175	7	175		
	approx	approx	approx	approx	approx	approx		

**FIG. 1 "Y" Blocks for Test Coupons**

cases, either of the test specimens shown in Fig. 6 shall be satisfactory.

11.2 By agreement between the manufacturer and the purchaser, tension test specimens may be cut directly from centrifugal or other permanent mold castings. The location and orientation of such tension test specimens cut from castings shall be specified as agreed upon by the manufacturer and the purchaser.

**12. Additional Tests**

12.1 Hydrostatic tests for pressure castings, radiography standards, fracture tests, microstructure standards, or any other special tests may be set up by mutual agreement between the manufacturer and the purchaser.

**13. Responsibility for Inspection**

13.1 Unless otherwise specified in the contract or purchase order, the manufacturer is responsible for the performance of all inspection requirements as specified herein. Except as otherwise specified in the contract or order, the manufacturer may use his own or any other facilities suitable for the performance of the inspection requirements specified herein, unless disapproved by the purchaser. The purchaser reserves the right to perform any of the inspections set forth in the specification where such inspections are deemed necessary to assure supplies and services conform to prescribed requirements.

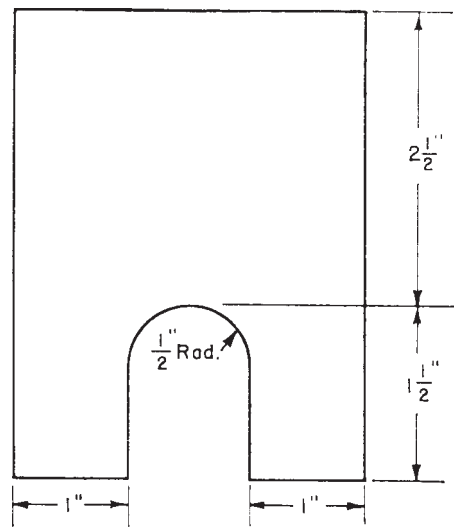

Metric Equivalents				
in.	1/2	1	1 1/2	2 1/2
mm	13	25	38	63

NOTE—The length of the keel block shall be 6 in. (150 mm).

**FIG. 2 Keel Block for Test Coupons**

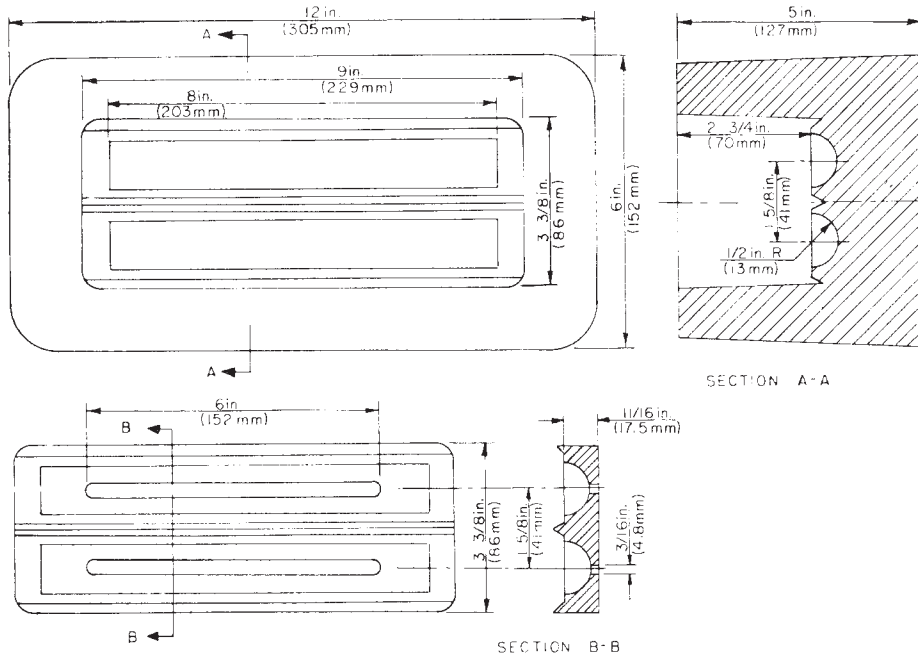

FIG. 3 Mold for Modified Keel Block

#### 14. Certification

14.1 When agreed upon in writing by the purchaser and the supplier, a certification shall be made the basis of acceptance of the material. This shall consist of a copy of the manufacturer's test report or a statement by the supplier, accompanied by a copy of the test results that the material has been tested and inspected in accordance with the provisions of this specification. Each certification so furnished shall be signed by an authorized agent of the supplier or manufacturer.

#### 15. Packaging and Package Marking

15.1 Unless otherwise specified in the contract or purchase

order, preservation and packaging of casting shall be in accordance with the manufacturer's commercial practice. Packing and marking shall also be adequate to ensure acceptance and safe delivery by the carrier for the mode of transportation employed.

#### 16. Keywords

16.1 austenitic; corrosion resistant; ductile iron; mechanical properties; nodular iron; tensile strength; yield strength

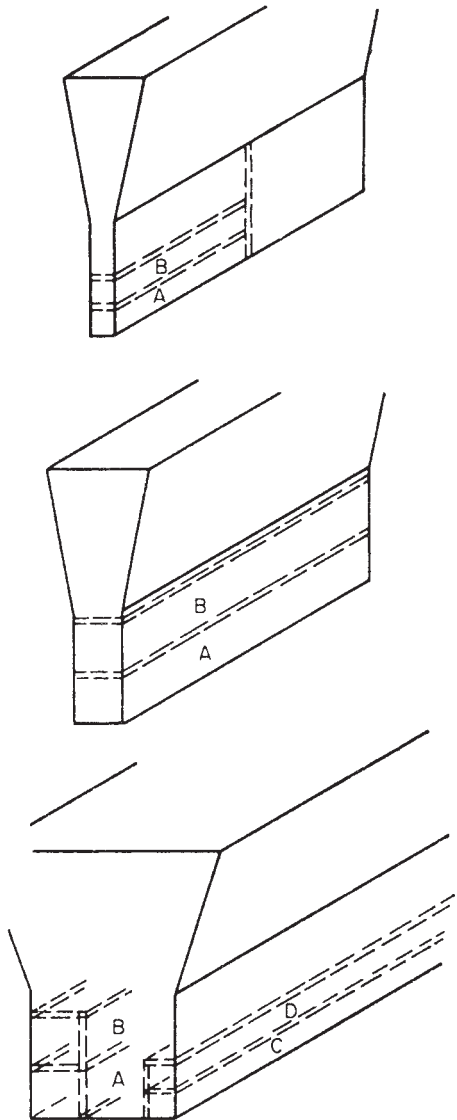

- (a) 1/2-in. (13-mm) "Y" Block—Two blanks for 0.252-in. (6.40-mm) diameter tension test specimens.
- (b) 1-in. (25-mm) "Y" Block—Two blanks for 0.50-in. (12.7-mm) diameter tension test specimens.
- (c) 3-in. (75-mm) "Y" Block—Two blanks for 0.50-in. (12.7-mm) diameter tension test specimens.

FIG. 4 Sectioning Procedure for "Y" Blocks

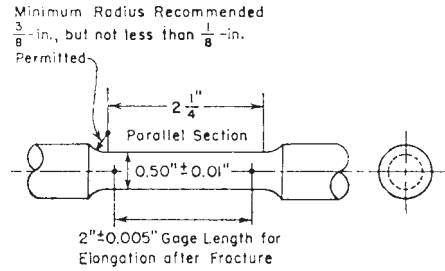

Metric Equivalents			
in.	mm	in.	mm
0.005	0.01	0.50	12.7
0.01	0.3	2	50.8
1/8	3.2	2 1/4	57.2
3/8	9.5		

NOTE—The gage length and fillets shall be as shown but the ends may be of any shape to fit the holders of the testing machine in such a way that the load shall be axial. The reduced section shall have a gradual taper from the ends toward the center, with the ends 0.003 to 0.005 in. (0.08 to 0.13 mm) larger in diameter than the center.

FIG. 5 Standard Round Tension Test Specimen with 2-in. (50.8-mm) Gage Length

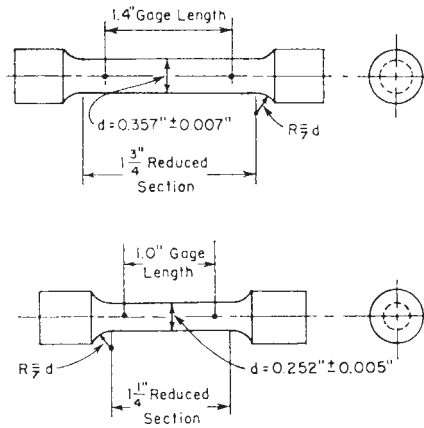

**Metric Equivalents**

in.	mm	in.	mm
0.005	0.13	1.0	25.4
0.007	0.18	1¼	31.8
0.252	6.40	1.4	35.6
0.357	9.07	1¾	44.4

NOTE—If desired, the length of the reduced section may be increased to accommodate an extensometer.

**FIG. 6 Examples of Small-Size Specimens Proportional to Standard ½-in. (12.7-mm) Round Specimen**

ASTM International takes no position respecting the validity of any patent rights asserted in connection with any item mentioned in this standard. Users of this standard are expressly advised that determination of the validity of any such patent rights, and the risk of infringement of such rights, are entirely their own responsibility.

This standard is subject to revision at any time by the responsible technical committee and must be reviewed every five years and if not revised, either reapproved or withdrawn. Your comments are invited either for revision of this standard or for additional standards and should be addressed to ASTM International Headquarters. Your comments will receive careful consideration at a meeting of the responsible technical committee, which you may attend. If you feel that your comments have not received a fair hearing you should make your views known to the ASTM Committee on Standards, at the address shown below.

This standard is copyrighted by ASTM International, 100 Barr Harbor Drive, PO Box C700, West Conshohocken, PA 19428-2959, United States. Individual reprints (single or multiple copies) of this standard may be obtained by contacting ASTM at the above address or at 610-832-9585 (phone), 610-832-9555 (fax), or service@astm.org (e-mail); or through the ASTM website (www.astm.org).