



Standard Specification for Steel Castings, General Requirements, for Pressure-Containing Parts¹

This standard is issued under the fixed designation A 703/A 703M; the number immediately following the designation indicates the year of original adoption or, in the case of revision, the year of last revision. A number in parentheses indicates the year of last reapproval. A superscript epsilon (ε) indicates an editorial change since the last revision or reapproval.

1. Scope

1.1 This specification² covers a group of common requirements that, unless otherwise specified in an individual specification, shall apply to steel castings for pressure-containing parts under each of the following ASTM specifications:

Title of Specification	ASTM Designation
Steel Castings, Carbon, Suitable for Fusion Welding for High-Temperature Service	A 216/A 216M
Steel Castings, Martensitic Stainless and Alloy, for Pressure-Containing Parts Suitable for High-Temperature Service	A 217/A 217M
Steel Castings, Austenitic, for High-Temperature Service	A 351/A 351M
Steel Castings, Ferritic and Martensitic, for Pressure-Containing Parts Suitable for Low-Temperature Service	A 352/A 352M
Steel Castings, Alloy, Specially Heat-Treated, for Pressure-Containing Parts, Suitable for High-Temperature Service	A 389/A 389M
Steel Castings Suitable for Pressure Service	A 487/A 487M

1.2 This specification also covers a group of supplementary requirements which may be applied to the above specifications as indicated therein. These are provided for use when additional testing or inspection is desired and apply only when specified individually by the purchaser in the order.

1.3 In case of conflict between the requirements of the individual specification and this general specification, the former shall prevail.

1.4 The values stated in either inch-pound units or SI units are to be regarded separately as standard. Within the text, the SI units are shown in brackets. The values stated in each system are not exact equivalents; therefore, each system must be used independently of the other. Combining values from the two systems may result in nonconformance with the specification. Inch-pound units are applicable for material ordered to Specification A 703 and SI units for material ordered to Specification A 703M.

2. Referenced Documents

2.1 ASTM Standards:

- A 216/A 216M Specification for Steel Castings, Carbon, Suitable for Fusion Welding, for High-Temperature Service³
- A 217/A 217M Specification for Steel Castings, Martensitic Stainless and Alloy, for Pressure-Containing Parts Suitable for High-Temperature Service³
- A 351/A 351M Specification for Castings, Austenitic, Austenitic-Ferritic (Duplex), for Pressure-Containing Parts³
- A 352/A 352M Specification for Steel Castings, Ferritic and Martensitic, for Pressure-Containing Parts, Suitable for Low-Temperature Service³
- A 370 Test Methods and Definitions for Mechanical Testing of Steel Products⁴
- A 380 Practice for Cleaning, Descaling, and Passivation of Stainless Steel Parts, Equipment, and Systems⁴
- A 389/A 389M Specification for Steel Castings, Alloy, Specially Heat-Treated, for Pressure-Containing Parts, Suitable for High-Temperature Service³
- A 487/A 487M Specification for Steel Castings Suitable for Pressure Service³
- A 488/A 488M Practice for Steel Castings, Welding, Qualification of Procedures and Personnel³
- A 609/A 609M Practice for Castings, Carbon, Low-Alloy, and Martensitic Stainless Steel, Ultrasonic Examination Thereof³
- A 751 Test Methods, Practices, and Terminology for Chemical Analysis of Steel Products⁴
- A 800/A 800M Practice for Steel Castings, Austenitic Alloy, Estimating Ferrite Content Thereof³
- A 802/A 802M Practice for Steel Castings, Surface Acceptance Standards, Visual Examination³
- A 903/A 903M Specification for Steel Castings, Surface Acceptance Standards, Magnetic Particle and Liquid Penetrant Inspection³

¹ This specification is under the jurisdiction of ASTM Committee A01 on Steel, Stainless Steel and Related Alloys and is the direct responsibility of Subcommittee A01.18 on Castings.

Current edition approved September 10, 2002. Published October 2002. Originally published as A 703 – 74. Last previous edition A 703/A 703M – 01b.

² For ASME Boiler and Pressure Vessel Code applications see related Specification SA-703/SA-703M in Section II of that Code.

³ Annual Book of ASTM Standards, Vol 01.02.

⁴ Annual Book of ASTM Standards, Vol 01.03.

 **A 703/A 703M – 02**

A 941 Terminology Relating to Steel, Stainless Steel, Related Alloys, and Ferroalloys⁵

A 967 Specification for Chemical Passivation Treatments for Stainless Steel Parts⁴

A 991/A 991M Test Method for Conducting Temperature Uniformity Surveys of Furnaces Used to Heat Treat Steel Products⁴

E 29 Practice for Using Significant Digits in Test Data to Determine Conformance With Specifications⁶

E 94 Guide for Radiographic Examination⁷

E 125 Reference Photographs for Magnetic Particle Indications on Ferrous Castings⁷

E 165 Test Method for Liquid Penetrant Examination⁷

E 186 Reference Radiographs for Heavy-Walled (2 to 4½-in. (51 to 114-mm)) Steel Castings⁷

E 208 Test Method for Conducting Drop-Weight Test to Determine Nil-Ductility Transition Temperature of Ferritic Steels⁸

E 280 Reference Radiographs for Heavy-Walled (4½ to 12-in. (114 to 305-mm)) Steel Castings⁷

E 340 Test Method for Macroetching Metals and Alloys⁸

E 446 Reference Radiographs for Steel Castings up to 2 in. (51 mm) in Thickness⁷

E 709 Guide for Magnetic Particle Examination⁷

2.2 *ANSI Standard:*

B16.5 Steel Pipe Flanges and Flanged Fittings⁹

2.3 *Standards of the Manufacturer's Standardization Society of the Valve and Fitting Industry:*

MSS SP 53 Quality Standard for Steel Castings for Valves, Flanges and Fittings, and Other Piping Components (Dry Powder Magnetic Particle Inspection Method)¹⁰

MSS SP 54 Quality Standard for Steel Castings for Valves, Flanges and Fittings, and Other Piping Components (Radiographic Inspection Method)¹⁰

3. Terminology

3.1 *Definitions:*

3.1.1 The definitions in Test Methods and Definitions A 370 and Terminology A 941 are applicable to this specification and those listed in 1.1.

3.1.2 *chaplet, n*—a chaplet is a metallic support placed in a mold cavity to maintain the spacing between a core and the mold.

3.1.3 *electronic data interchange (EDI), n*—the computer-to-computer exchange of business information in a standard format such as ANSI ASC X12.

3.1.4 *heat, n*—all the molten metal poured from a single furnace or all the molten metal from two or more furnaces poured into a single ladle or casting prior to the replenishing of the furnace(s).

3.1.5 *internal chill, n*—an internal chill is a metallic device placed in a mold cavity to increase the rate of heat removal at that location.

4. Materials and Manufacture

4.1 *Melting Process*—The steel shall be made by open-hearth or electric-furnace process, with or without separate refining such as argon-oxygen-decarburization (AOD), unless otherwise designated by the individual specification.

4.2 *Heat Treatment*—Ferritic and martensitic steel shall be cooled after pouring to provide substantially complete transformation of austenite prior to heat treatment to enhance mechanical properties.

5. Chemical Composition

5.1 *Chemical Analysis*—Chemical analysis of materials covered by this specification shall be in accordance with Test Methods A 751.

5.2 *Heat Analysis*—An analysis of each heat shall be made by the manufacturer to determine the percentages of the elements specified. The analysis shall be made from a test sample preferably taken during the pouring of the heat. When drillings are used, they shall be taken not less than ¼ in. [6.4 mm] beneath the surface. The chemical composition thus determined shall be reported to the purchaser, or his representative, and shall conform to the requirements in the individual specification for the grade being poured.

5.3 *Product Analysis*—A product analysis may be made by the purchaser from material representing each heat, lot, or casting. The analysis shall be made on representative material. Due to the possibility of decarburization, carbon and alloy steel samples for carbon analysis shall be taken no closer than ¼ in. [6.4 mm] to a cast surface except that castings too thin for this shall be analyzed on representative material. The chemical composition thus determined shall meet the requirements specified in the applicable specification for the grade involved, or shall be subject to rejection by the purchaser, except that the chemical composition determined for carbon and low-alloy steel castings may vary from the specified limits by the amounts shown in Table 1. The product analysis tolerances of Table 1 are not applicable as acceptance criteria for heat analysis by the casting manufacturer.

5.4 *Unspecified Elements*—When chemical analysis for elements not specified for the grade ordered is desired, Supplementary Requirement S1 may be specified.

5.4.1 Grade substitution for stainless and nickel base alloy castings is not permitted. Grade substitution occurs when the material supplied: (1) contains an element, other than the nitrogen, that is not specified in the ordered grade, and (2) the amount of that element equals or exceeds the minimum requirement for the element in another grade for which it is specified. For this requirement, a grade is defined as an alloy described individually in a table of chemical requirements within any specification listed within the scope of this section.

5.5 The substitution of a grade or composition different from that specified by the purchaser is prohibited.

5.6 Where more than one ladle is poured into a single casting, the molten metal in each ladle must conform to the specified chemical requirements.

⁵ Annual Book of ASTM Standards, Vol 01.01.

⁶ Annual Book of ASTM Standards, Vol 14.02.

⁷ Annual Book of ASTM Standards, Vol 03.03.

⁸ Annual Book of ASTM Standards, Vol 03.01.

⁹ Available from American National Standards Institute, 25 W. 43rd St., 4th Floor, New York, NY 10036.

¹⁰ Available from the Manufacturers' Standardization Society of the Valve and Fittings Industry, 127 Park St., NE, Vienna, VA 22180.

TABLE 1 Product Analysis Tolerances for Carbon and Low-Alloy Steels

Element	Range ^A	Tolerances ^{B,C} over max or under min, Limit, %
Carbon (C)	up to 0.65 % above 0.65 %	$0.03 \times \% C_L + 0.02$ 0.04 %
Manganese (Mn)	up to 1 % above 1 %	$0.08 \times \% Mn_L + 0.01$ 0.09
Silicon (Si)	up to 0.60 % above 0.60 %	$0.22 \times \% Si_L - 0.01$ 0.15 %
Phosphorus (P)	all	$0.13 \times \% P_L + 0.005$
Sulfur (S)	all	$0.36 \times \% S_L + 0.001$
Nickel (Ni)	up to 2 % above 2 %	$0.10 \times \% Ni_L + 0.03$ 0.25 %
Chromium (Cr)	up to 2 % above 2 %	$0.07 \times \% Cr_L + 0.04$ 0.18 %
Molybdenum (Mo)	up to 0.6 % above 0.6 %	$0.04 \times \% Mo_L + 0.03$ 0.06 %
Vanadium (V)	up to 0.25 % above 0.25 %	$0.23 \times \% V_L + 0.004$ 0.06 %
Tungsten (W)	up to 0.10 % above 0.10 %	$0.08 \times \% W_L + 0.02$ 0.02 %
Copper (Cu)	up to 0.15 % above 0.15 %	$0.18 \times \% Cu_L + 0.02$ 0.05 %
Aluminum (Al)	up to 0.03 % 0.03 to 0.10 %, incl. above 0.10 %	0.01 % $0.08 \times \% Al + 0.02$ 0.03 %

^A The range denotes the composition limits up to which the tolerances are computed by the equation, and above which the tolerances are given by a constant.

^B The subscript _L for the elements in each equation indicates that the limits of the element specified by the applicable specification are to be inserted into the equation to calculate the tolerance for the upper limit and the lower limit, if applicable, respectively. Examples of computing tolerances are presented in the footnote C.

^C To compute the tolerances, consider the manganese limits 0.50 – 80 % of Grade WC4 of Specification A 217/A 217M. According to Table 1, the maximum permissible deviation of a product analysis below the lower limit 0.50 is 0.05 % = $(0.08 \times 0.50 + 0.01)$. The lowest acceptable product analysis of Grade WC4, therefore, is 0.45 %. Similarly, the maximum permissible deviation above the upper limit of 0.80 % is 0.074 % = $(0.08 \times 0.80 + 0.01)$. The highest acceptable product analysis of Grade WC4, therefore, is 0.874. For Grade WCC of Specification A 216/A 216M, the maximum manganese content is 1.20 % if the carbon content is 0.20 %. In this case, the highest acceptable product analysis is 1.29 = $(1.20 + 0.09)$.

6. Mechanical Test Methods

6.1 All mechanical tests shall be conducted in accordance with Test Methods and Definitions A 370.

7. Tensile Requirements

7.1 One tension test shall be made from each heat, and shall

conform to the tensile requirements specified. Test bars shall be poured in special blocks from the same heat as the castings represented, except that for investment castings the test specimens shall be cast in the same type of mold as the castings.¹¹

7.2 The bar from which the test specimen is taken shall be heat treated in production furnaces to the same procedure as the castings it represents.

7.3 Test specimens may be cut from heat treated castings, at the producer's option, instead of from test bars.

7.4 *Investment Castings*—For investment castings, the specimens may be cast to shape or machined from blocks to dimensions in accordance with Test Methods and Definitions 370 or the ICI bar shown in Fig. 1.

7.5 *Other Castings*— Unless otherwise specified by the purchaser, test coupons may be cast integrally with the castings or as separate blocks in accordance with Fig. 2 and Table 2, with Fig. 3, or with Fig. 4, except when Supplementary Requirement S26 is specified. The test coupon in Fig. 4 shall be employed only for austenitic alloy castings with cross sections less than 2½ in. [63.5 mm]. Tension test coupons shall be machined or ground to the form and dimension shown in Fig. 6 of Test Methods and Definitions A 370.

7.6 If any specimen shows defective machining or develops flaws, it may be discarded and another substituted from the same heat.

7.7 To determine conformance with the tension test requirements, an observed value or calculated value shall be rounded off in accordance with Practice E 29 to the nearest 500 psi [5 MPa] for yield and tensile strength and to the nearest 1 % for elongation and reduction of area.

8. Repair by Welding

8.1 Repair by welding shall be in accordance with the requirements of individual specification using procedures and welders qualified in accordance with Practice A 488/A 488M.

¹¹ Information on the relationship of mechanical properties determined on test coupons obtained as specified in 7.1 and 7.4 with those obtained from the casting may be found in "The Steel Castings Handbook," Fifth Edition, Steel Founders' Society of America, 1980, pp. 15–35 through 15–43.

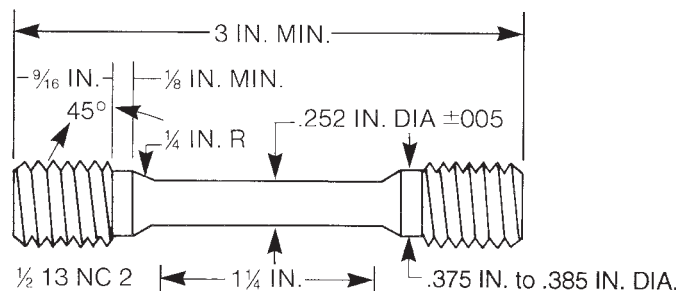

Metric Equivalents

in.	0.005	1/8	0.252	0.375	0.385	9/16	1 1/4	3
[mm]	[0.15]	[3]	[6.40]	[9.50]	[9.75]	[15]	[30]	[75]

FIG. 1 Design and Dimensions of the ICI Test Bar

ASTM A 703/A 703M – 02

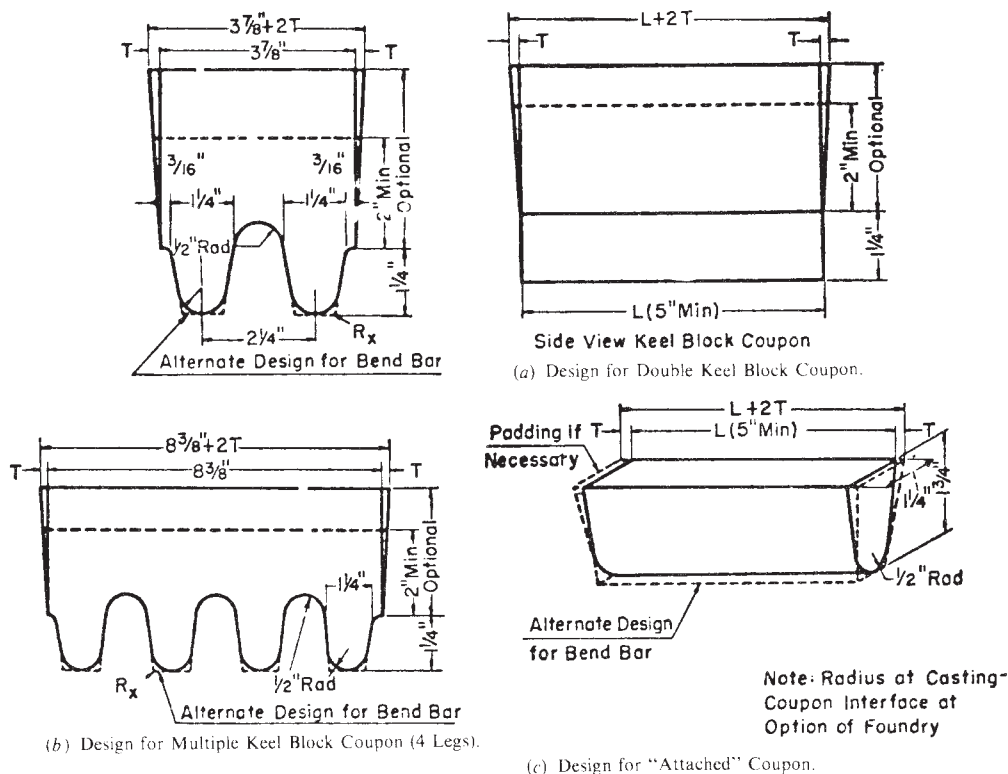

Metric Equivalents

in.	3/16	1/2	1 1/4	1 3/4	2	2 1/4	3 7/8	5	8 1/8
mm	4.8	13	32	45	51	57	98	127	213

FIG. 2 Test Coupons for Castings (see Table 2 for Details of Design)

TABLE 2 Details of Test Coupon Design for Casting (See Fig. 2)

NOTE 1—Test Coupons for Large and Heavy Steel Castings: The test coupons in Fig. 2 are to be used for large and heavy steel castings. However, at the option of the foundry the cross-sectional area and length of the standard coupon may be increased as desired.

NOTE 2—Bend Bar: If a bend bar is required, an alternate design (as shown by dotted lines in Fig. 2) is indicated.

	Leg Design [125 mm]		Riser Design
1. L (length)	A 5 in. [125 mm] minimum length will be used. This length may be increased at the option of the foundry to accommodate additional test bars (see Note 1).	1. L (length)	The length of the riser at the base will be the same as the top length of the leg. The length of the riser at the top therefore depends on the amount of taper added to the riser.
2. End taper	Use of and size of end taper is at the option of the foundry.	2. Width	The width of the riser at the base of a multiple-leg coupon shall be $n, 2 \frac{1}{4}$ [57 mm] – $\frac{5}{8}$ [16 mm] where n equals the number of legs attached to the coupon. The width of the riser at the top is therefore dependent on the amount of taper added to the riser.
3. Height	1 1/4 in. [32 mm]	3. T (riser taper)	Use of and size is at the option of the foundry.
4. Width (at top)	1 1/4 in. [32 mm] (see Note 1).	Height	The minimum height of the riser shall be 2 in. [51 mm]. The maximum height is at the option of the foundry for the following reasons: (a) Many risers are cast open, (b) different compositions may require variation in risering for soundness, (c) different pouring temperatures may require variation in risering for soundness.
5. Radius (at bottom)	1/2 in. [13 mm], max		
6. Spacing between legs	A 1/2-in. [13-mm] radius will be used between the legs.		
7. Location of test bars	The tensile, bend, and impact bars will be taken from the lower portion of the leg (see Note 2).		
8. Number of legs	The number of legs attached to the coupon is at the option of the foundry providing they are equispaced according to Item 6.		
9. R _s	Radius from 0 to approximately 1/16 in. [2 mm].		

9. Flanges

9.1 When a flange from a flanged casting is removed to make a weld end casting, discontinuities may be observed that would not have been detrimental in a flanged casting. The disposition of the casting shall be subject to agreement between the purchaser and manufacturer.

10. Quality

10.1 The surface of the casting shall be free of adhering sand, scale, cracks, and hot tears as determined by visual examination. Other surface discontinuities shall meet the visual acceptance standards specified in the order. Practice A 802/ A 802M or other visual standards may be used to define

ASTM A 703/A 703M – 02

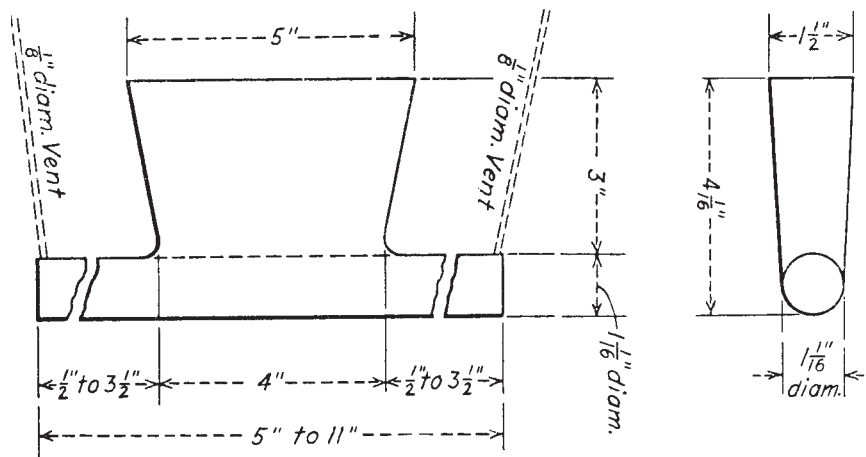

Metric Equivalents

in.	mm	in.	mm
1/8	3.2	3 1/2	88.9
1/2	12.7	4	101.6
1 1/16	27.0	4 1/16	103.2
1 1/2	38.1	5	127.0
3	76.2	11	279.4

NOTE 1—Pour through head; cover molten head with powdered charcoal, coke dust, etc., immediately after pouring, in order to keep head fluid as long as possible.

FIG. 3 Test Block for Tension Test Specimen

acceptable surface discontinuities and finish. Unacceptable visual surface discontinuities shall be removed and their removal verified by visual examination of the resultant cavities.

10.2 The castings shall not be peened, plugged, or impregnated to stop leaks.

10.3 Internal chills and chaplets may be used in the manufacture of castings. However, the chills, chaplets, and affected cast material must be completely removed.

11. Hydrostatic Tests

11.1 Each casting shall be tested after machining to the hydrostatic shell test pressures prescribed in ANSI B16.5 for the applicable steel rating for which the casting is designed. Casting shall show no leaks. Castings ordered for working pressures other than those in the standard ANSI ratings, or those listed for which test pressures are not specified by ANSI B16.5, shall be tested at a pressure agreed upon between manufacturer and the purchaser.

11.2 It is realized that the foundry may be unable to perform the hydrostatic test prior to shipment, or that the purchaser may wish to defer testing until additional work or machining has been performed on the casting. Castings ordered in the rough state for final machining by the purchaser may be tested hydrostatically prior to shipment by the manufacturer at pressures to be agreed upon with the purchaser. However, the foundry is responsible for the satisfactory performance of the castings under the final test required in 10.1.

12. Workmanship, Finish, and Appearance

12.1 All castings shall be made in a workmanlike manner and shall conform to the dimensions on drawings furnished by

the purchaser. When the pattern is supplied by the purchaser, the dimensions of the casting shall be as predicated by the pattern unless otherwise agreed upon.

12.2 Machined welding ends shall be suitably protected against damage during shipping.

13. Retests

13.1 If the results of the mechanical tests for any heat, lot, or casting do not conform to the requirements specified, retests are permitted as outlined in Test Methods and Definitions A 370. At the manufacturer's option, castings may be reheat-treated and retested. When castings are reheat-treated, they may not be reautenitized more than three times without the approval of the purchaser. Testing after reheat treatment shall consist of the full number of specimens taken from locations complying with the specification or order.

14. Inspection

14.1 The manufacturer shall afford the purchaser's inspector all reasonable facilities necessary to satisfy that the material is being produced and furnished in accordance with the applicable specification. Foundry inspection by the purchaser shall not interfere unnecessarily with the manufacturer's operations. All tests and inspections, with the exception of product analysis (5.2), shall be made at the place of manufacture unless otherwise agreed.

15. Rejection and Rehearing

15.1 Any rejection based on test reports shall be reported to the manufacturer within 30 days from the receipt of the test reports by the purchaser.

15.2 Material that shows unacceptable discontinuities as determined by the acceptance standards specified in the order

ASTM A 703/A 703M – 02

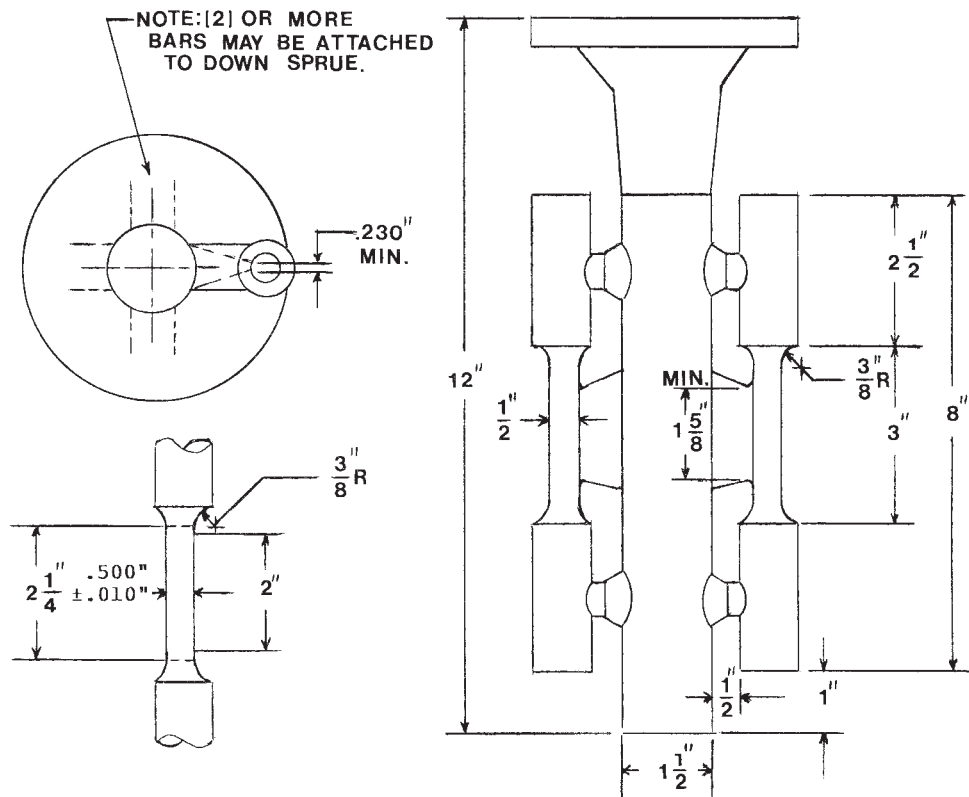

Metric Equivalents

in.	mm	in.	mm
0.010	0.254	1 5/8	41.275
0.230	5.842	2 1/4	57.15
3/8	9.525	2 1/2	63.5
1/2	12.7	3	76.2
1	25.4	8	203.2
1 1/2	38.1	12	304.8

NOTE—Coupons produced in this manner are suitable for austenitic alloys only. The mold may be preheated for pouring to produce a sound coupon.

FIG. 4 Cast-To-Shape Test Coupon for Tension Test Specimen

subsequent to its acceptance at the manufacturer's works will be rejected, and the manufacturer shall be notified within 30 days after discovery of the rejectable condition.

15.3 Samples that represent rejected material shall be preserved for two weeks from the date of transmission of the test report. In case of dissatisfaction with the results of the tests, the manufacturer may make claim for a rehearing within that time.

16. Certification

16.1 The manufacturer's certification shall be furnished to the purchaser stating that the material was manufactured, sampled, tested, and inspected in accordance with the material specification (including year of issue) and was found to meet the requirements.

16.2 As applicable, the certification shall also include:

- 16.2.1 Material specification and grade,
- 16.2.2 Pattern number,
- 16.2.3 Heat number or serial number traceable to a heat number,
- 16.2.4 Chemical analysis of the heat,
- 16.2.5 Mechanical property results required by the speci-

fication and supplementary requirements specified in the purchase order,

16.2.6 Statement of satisfactory inspection, visual, and non-destructive testing specified in the purchase order,

16.2.7 Manufacturer's name, and

16.2.8 Additional purchase order requirements.

16.3 A signature is not required on the certification. However, the document shall clearly identify the organization submitting the certification. Notwithstanding the absence of a signature, the organization submitting the certification is responsible for its content.

16.4 A manufacturer's certification printed from or used in electronic form from an electronic data interchange (EDI) transmission shall be regarded as having the same validity as a counterpart printed in the certifier's facility provided it conforms to any existing EDI agreement between the purchaser and the supplier.

17. Product Marking

17.1 Castings shall be marked for material identification with the grade symbols (WCB, WC9, CF8M, and so forth). In



addition, heat numbers, or serial numbers that are traceable to heat numbers, shall be marked on all pressure-containing castings individually weighing 50 lb [22.7 kg] or more. Pressure-containing castings weighing less than 50 lb [22.7 kg] shall be marked with either the heat number or a lot number that will identify the casting as to the month in which it was poured. Marking shall be in such position as not to injure the usefulness of the casting.

17.2 On castings for which impact property requirements are specified, stamped markings using low-stress stamps shall

be on a raised pad when such pad can be made a part of the castings.

17.3 Castings shall be marked with the manufacturer's identification or symbol except when other provisions have been made between the manufacturer and purchaser.

18. Keywords

18.1 castings; general requirements; pressure containing; steel

SUPPLEMENTARY REQUIREMENTS

The following standardized supplementary requirements are for use when desired by the purchaser and when allowed by and listed in the individual specifications. They shall not apply unless specified in the order, in which event the specified tests shall be made by the manufacturer before shipment of the castings.

S1. Unspecified Elements

S1.1 Limits may be established for elements not specified for the grade ordered by agreement between the manufacturer and purchaser. The results of the analysis for the agreed-upon elements shall be reported.

S2. Destruction Tests

S2.1 Purchaser may select representative castings from each heat and cut up and etch, or otherwise prepare, the sections for examination for internal defects. Should injurious defects be found that evidence unsound steel or faulty foundry technique, all the castings made from that particular pattern, heat, and heat treatment charge may be rejected. All the rejected castings, including those cut up, shall be replaced by the manufacturer without charge.

S3. Bend Test

S3.1 One bend test shall be made from a test coupon from each heat in accordance with Test Methods and Definitions A 370, and shall be machined to 1 by 1/2-in. [25 by 13-mm] section with corners rounded to a radius not over 1/16 in. [1.6 mm].

S3.2 The specimen shall withstand being bent longitudinally at room temperature through an angle of 90° about a pin the diameter of which shall be the specimen thickness for carbon steels, and 1 in. [25 mm] for other steels. The specimen shall show no cracks on the outside of the bent portion of the specimen.

S3.3 Bend test specimens may be cut from heat-treated castings instead of from test bars when agreed upon between manufacturer and purchaser.

S3.4 If any test specimen shows defective machining or develops flaws, it may be discarded and another specimen substituted from the same heat.

S4. Magnetic Particle Inspection

S4.1 Castings shall be examined for surface and near surface discontinuities by magnetic particle inspection. The examination shall be in accordance with Guide E 709; and

types and degrees of discontinuities considered shall be judged by the Reference Photographs E 125. Extent of examination, time of examination, and basis for acceptance shall be agreed upon between the manufacturer and purchaser. A specification which may be used as a basis for such agreement is MSS SP 53.

S4.2 Personnel performing the examination shall be qualified in accordance with an acceptable written practice.

S5. Radiographic Inspection

S5.1 Castings shall be examined for internal defects by means of X rays or gamma rays. The procedure shall be in accordance with Guide E 94 and types and degrees of discontinuities considered shall be judged by Reference Radiographs E 446, E 186, or E 280. Extent of examination and basis for acceptance shall be agreed upon between the manufacturer and purchaser. A specification that may be used as a basis for such agreement is MSS SP 54.

S5.2 Radiographic examination of castings may be performed before or after any heat treatment.

S5.3 Personnel performing the examination shall be qualified in accordance with an acceptable written practice.

S6. Liquid Penetrant Inspection

S6.1 Castings shall be examined for surface discontinuities by means of liquid penetrant inspection. The examination shall be in accordance with Test Method E 165. Areas to be inspected, time of inspection, methods and types of liquid penetrants to be used, developing procedure, and basis for acceptance shall be agreed upon between the manufacturer and purchaser. A specification that may be used as a basis for such agreement is Specification A 903/A 903M.

S6.2 Personnel performing the examination shall be qualified in accordance with an acceptable written practice.

S7. Ultrasonic Inspection

S7.1 Castings shall be examined for internal defects by means of ultrasonic inspection. The inspection procedure shall be in accordance with Practice A 609/A 609M. Extent of

 **A 703/A 703M – 02**

examination, methods of testing, and basis for acceptance shall be agreed upon between the manufacturer and purchaser. A standard that may be used as a basis for such agreement is Practice A 609/A 609M.

S7.2 Ultrasonic examination of castings shall be performed after at least one heat treatment above the critical temperature range but need not be repeated after subsequent heat treatment.

S7.3 Personnel performing the examination shall be qualified in accordance with an acceptable written practice.

S8. Charpy Impact Test

S8.1 Charpy impact test properties shall be determined on each heat from a set of three charpy V-notch specimens made from a test coupon in accordance with Test Methods and Definitions A 370, and tested at a test temperature agreed upon by the manufacturer and purchaser. The acceptance requirements shall be either energy absorbed, lateral expansion, or percent shear area, or all three, and shall be that agreed upon by the manufacturer and purchaser. Test specimens shall be prepared as Type A and tested in accordance with Test Methods and Definitions A 370.

S8.2 *Absorbed Energy*—Average energy value of three specimens shall be not less than specified, with not more than one value permitted to fall below the minimum specified and no value permitted below the minimum specified for a single specimen.

S8.3 *Lateral Expansion*—Lateral expansion value shall be agreed upon by the manufacturer and purchaser.

S8.4 *Percent Shear Area*—Percent shear area shall be agreed upon by the manufacturer and purchaser.

S9. Drop Weight Tests

S9.1 Drop weight test properties shall be determined from each heat by preparing and testing either Type P1, P2, or P3 specimens in accordance with Test Method E 208. The crack starter weld shall be deposited on the surface of the specimen that was nearest to the casting surface. Each test shall consist of at least two specimens tested at a temperature agreed upon by the manufacturer and purchaser. Each specimen shall exhibit “no break” performance.

S10. Examination of Weld Preparation

S10.1 Magnetic particle or liquid penetrant examination of cavities prepared for welding shall be performed to verify removal of those discontinuities found unacceptable by the inspection method specified for the casting. The method of performing magnetic particle or liquid penetrant examination shall be in accordance with Guide E 709 or Test Method E 165. Unless other degrees of shrinkage or types of discontinuities found in the cavities are specified, Type II, Internal Shrinkage, of Reference Photographs E 125, of Degree 2 in sections up to 2 in. [50 mm] thick and of Degree 3 in sections over 2 in. [50 mm] thick shall be acceptable.

S12. Prior Approval of Major Weld Repairs

S12.1 Major weld repairs shall be subject to the prior approval of the purchaser.

S13. Hardness Test

S13.1 A hardness test shall be made in accordance with Test

Methods and Definitions A 370. The test location and the hardness requirements shall be agreed upon between the manufacturer and the purchaser.

S14. Tension Test from Each Heat and Heat Treatment Charge

S14.1 One tension test shall be made for each heat and heat treatment charge.

S15. Quench and Temper Heat Treatment

S15.1 The castings shall be quenched and tempered. Castings so treated shall be marked QT.

S17. Tension Test from Castings

S17.1 In addition to the tensile test required in Section 6, test material shall be cut from heat treated castings. The mechanical properties and location for the test material shall be agreed upon by the manufacturer and purchaser.

S18. Tension Test for Castings Each Weighing 10 000 lb [4500 kg] or More

S18.1 Two tensile tests shall be made for each casting. The test specimens shall be prepared in accordance with Section 6. The location of the test bars shall be agreed upon by the manufacturer and purchaser.

S20. Weld Repair Charts

S20.1 Unless other criteria are agreed upon between the manufacturer and the purchaser, weld repairs made to correct leakage on hydrostatic testing; or weld repairs for which the depth of the cavity required for welding exceeds 20 % of the actual wall thickness or 1 in. [25 mm], whichever is smaller; or weld repairs for which the area of the cavity required for welding exceeds approximately 10 in.² [65 mm²], shall be documented.

S20.2 Weld repairs requiring documentation shall be documented on sketches or photographs, or both. The sketches or photographs shall show the location and major dimensions of cavities prepared for weld repair. The weld repair documentation shall be submitted to the purchaser at the completion of the order.

S21. Heat Treatment Furnace Record

S21.1 A heat treatment chart showing time and temperature shall be prepared and be available for inspection by the purchaser.

S22. Heat Treatment

S22.1 Test specimens shall be heat-treated together with the castings they represent. Heat-treated specimens shall be tested and shall meet the tensile and impact properties specified.

S22.2 The remaining test specimens from Supplementary Requirement S22.1 representing the casting shall be treated thermally after the final (foundry) heat-treatment to simulate heat-treatments below the critical temperature which the casting may receive during fabrication, and then tested for mechanical properties. Time, temperature and cooling rate shall be as stated in the order. In the case of postweld heat-treatment, the total time at temperature or temperatures for the test

ASTM A 703/A 703M – 02

material shall be at least 80 % of the total time at temperature or temperatures during actual postweld heat-treatment of the fabrication of which the casting or castings are a part. The total time at temperature or temperatures for the test material may be performed in a single cycle. When this Supplementary Requirement is specified, the welding qualification test metal must be processed in the same manner.

S23. Macroetch Test

S23.1 Apply Supplementary Requirement S1 for the spectrographic determination and reporting of the total residual aluminum content of all heats of ferritic and martensitic steels subjected to this macroetch test.

S23.2 When the heat analysis indicates a total residual aluminum content in excess of 0.08 %, the manufacturer shall etch a cross section of the casting with the heaviest section for which this supplementary requirement is invoked, or a coupon attached to that heaviest section or an area directly under a riser (Note S23.1). Cross sections, from a separately cast test block from the same heat and of a thickness representative of the heaviest section of castings purchased under this supplementary requirement, may also be used for macroetch testing. The etching shall be performed on the selected section after its heat-treatment, that is, after annealing, normalizing, or quenching and tempering following the initial cooling of the steel below the transformation range.

NOTE S23.1—High strength martensitic castings, in particu-

lar, may be damaged beyond use if the etch is applied directly to the casting.

S23.3 The preparation of the surface and the macroetching procedure with solution No. 1 (1:1 HCl) of Table 5 in Test Method E 340 shall be followed. The resulting etched surface shall be compared and rated with the reference photographs in Fig. S23.1 depicting 10 levels of severity of intergranular network structures indicative of the presence of aluminum nitride, or other constituents prone toward precipitating at grain boundaries during solidification and subsequent cooling. Table S23.1 relates the severity levels shown in these photographs with specific delineation widths and percent of boundary outlining in the etched structures.

S23.4 Castings represented by etched structures exhibiting a network rating in excess of Severity Level 4 shall be considered unacceptable until further evaluations are completed. The acceptability of individual castings may be determined by etching sections of each casting to ascertain the network severity level. Disposition of unacceptable castings shall be a matter of agreement between the manufacturer and purchaser. Those castings exhibiting etched severity levels greater than four may be further evaluated by any of the following agreed upon methods:

S23.4.1 Fracture testing to determine the amount of “rock candy” structure.

S23.4.2 Mechanical testing (bend, tensile, and so forth) to determine the ductility characteristics.

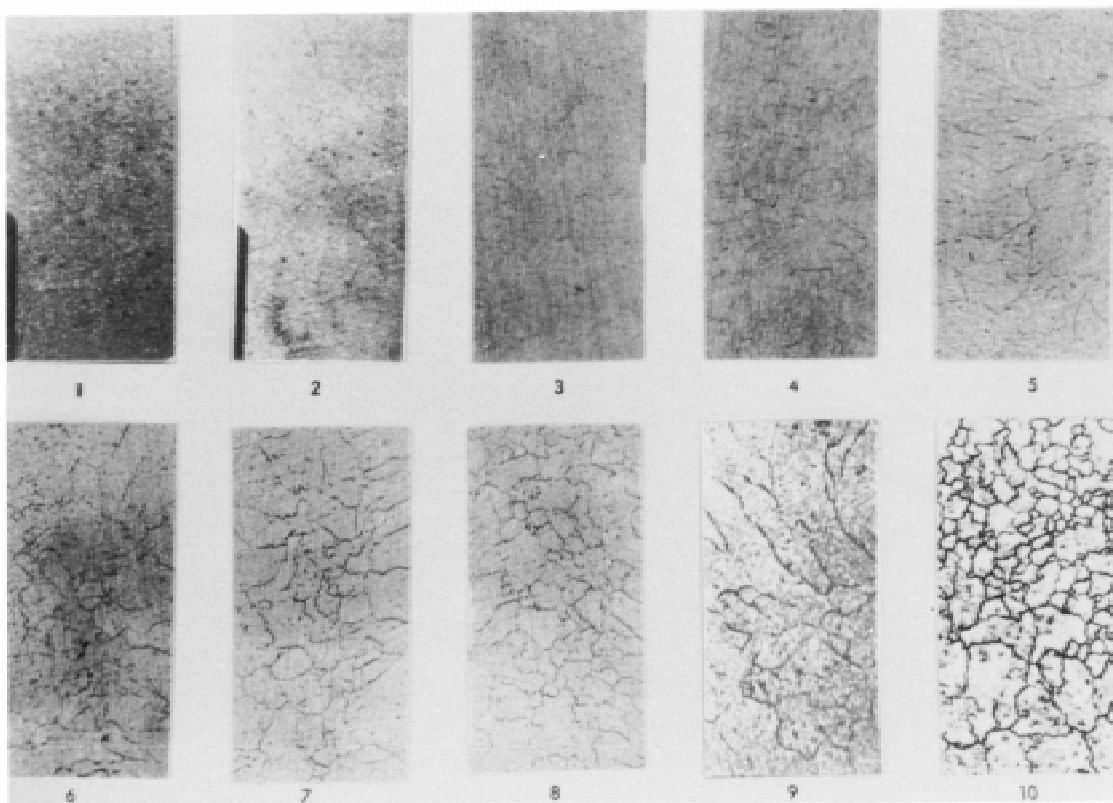

NOTE 1—The 10 levels of severity of intergranular network structures shown are indicative of the presence of aluminum nitride precipitation in the primary austenitic grain boundaries.

FIG. S23.1 Reference Photographs of Macroetched Cast Steel

TABLE S23.1 Descriptive Data Applicable to Network Structures Shown in Fig. S23.1

NOTE 1—These ratings are based on the physical width and continuity of the precipitate pattern developed by the acid etchant on the primary austenitic grain boundaries of the cast steel. Supplementary testing is normally conducted to determine the final disposition of castings with ratings of 5 or greater.

Rating	Delineation Width, in.	Boundary Outline, %
1	Fine–0.001	20
2	Fine–0.001	40
3	Fine–0.001	60
4	Fine–0.002	80
5	Fine–0.002	100
6	Medium–0.005	100
7	Heavy–0.010	100
8	0.020	100
9	1/32	100
10	1/16	100

S23.4.3 Weld testing to determine crack susceptibility in the heat-affected zone of a circular groove welded with cellulose coated electrodes.

S23.5 Alternatively, by agreement, it is permissible to subject castings from an unacceptable heat to a high temperature solution treatment prior to the normal production heat-treatment and subsequently macroetch test each casting.

S23.6 Heavy section castings (3) whose configurations are amenable to the attachment of test coupons representative of the section thickness involved and from which standard 0.505 in. [12.827 mm] diameter tension specimens may be machined are exempt from this macroetch test if the results of the tension test on the coupon after heat-treatment of the casting meet the minimum requirements specified for the grade of steel involved.

NOTE S23.2—For purposes of this supplementary requirement, a heavy section casting is defined as one having a wall thickness of 1½ in. [37 mm] or greater in combination with a casting weight of at least 1000 lb [455 kg].

S24. Specified Ferrite Content Range

S24.1 The chemical composition of the heat shall be controlled such that the ferrite content, as determined by the chemical composition procedure of Practice A 800/A 800M, shall be in conformance with the specified ferrite content range.

S24.2 The specified ferrite content range shall be as agreed upon between the manufacturer and the purchaser. The minimum specified ferrite content range shall be 10 % with the minimum ferrite content being no lower than the percent necessary to achieve the minimum mechanical properties required for the alloy.

S24.3 Should the purchaser wish to have the ferrite content determined by either magnetic response or metallographic methods, the purchaser should impose supplementary requirement S1 or S2 of Practice A 800/A 800M.

S25. Heat Treatment Certification

S25.1 Heat treatment temperature and cycle times shall be shown on the certification report.

S26. Alternate Tension Test Coupons and Specimen Locations for Castings (in-lieu of Test Bars Poured from Special Blocks)

S26.1 Test blocks may be cast integrally with the castings or as separate blocks. Test blocks shall be heat-treated together with the castings they represent.

S26.2 The casting thickness, *T*, is the maximum thickness of the pressure containing wall of the casting exclusive of padding added for directional solidification, flanges, appendages, and sections designated by the designer as noncritical. The order, inquiry, and drawing shall designate what the test dimension, *T*, is for the casting.

S26.3 One of the following shall apply:

S26.3.1 The longitudinal centerline of the test specimen shall be taken at least ¼ *T* from the *T* dimension surface and all of the gage length must be at least 1*T* from any other heat-treated surface, exclusive of the surface opposite the *T* dimension surface. (See Fig. S26.1 (a).) For cylindrical castings, the longitudinal centerline of the specimens shall be taken at least ¼ *T* from the outside or inside and all of the gage length must be at least *T* from the as-heat-treated end. (See Fig. S26.1 (b).)

S26.3.2 For ferritic and martensitic castings, partial severing of test blocks prior to final heat treatment is permitted.

S26.3.3 Where separately cast test coupons are used, the dimension shall not be less than 3 *T* by 3 *T* by *T* and each specimen shall meet the requirements of S26.3.1, except that when *T* exceeds 5 in. [125 mm], the dimension may be 15 by 15 by 5 in. [375 by 375 by 125 mm], by agreement between the manufacturer and the purchaser. The test coupon shall be of the same heat of steel and shall receive substantially the same casting practices as the production casting it represents. Centrifugal castings may be represented by statically cast coupons. (See Fig. S26.2.)

S26.3.4 When agreed upon between the manufacturer and the purchaser, castings that are cast or machined to essentially the finished configuration prior to heat-treatment shall have test specimens removed from a prolongation or other stock on the casting at a location below the nearest heat-treated surface indicated on the order. The specimen location shall be at a distance below the nearest heat-treated surface equivalent to at least the greatest distance that the indicated high-tensile-stress surface will be from the nearest heat-treated surface and a minimum of twice this distance from a second heat-treated surface, except that the test specimens shall be no nearer than ¾ in. [19 mm] to a heat-treated surface and 1½ in. [38 mm] from a second heat-treated surface. (See Fig. S26.3.)

S26.3.5 Where specimens are to be removed from the body of quenched and tempered castings, either the requirements of S26.3.1 shall be met or a steel thermal buffer pad or thermal insulation or other thermal barriers shall be used during heat-treatment. Steel thermal buffer pads shall be a minimum of *T* by *T* by 3 *T* in length and shall be joined to the casting surface by a partial penetration weld completely sealing the buffered surface. Test specimens shall be removed from the casting in a location adjacent to the center third of the buffer pad. They shall be located at a minimum distance of ½ in. [13 mm] from the buffered surface and ¼ *T* from other heat-treated

ASTM A 703/A 703M - 02

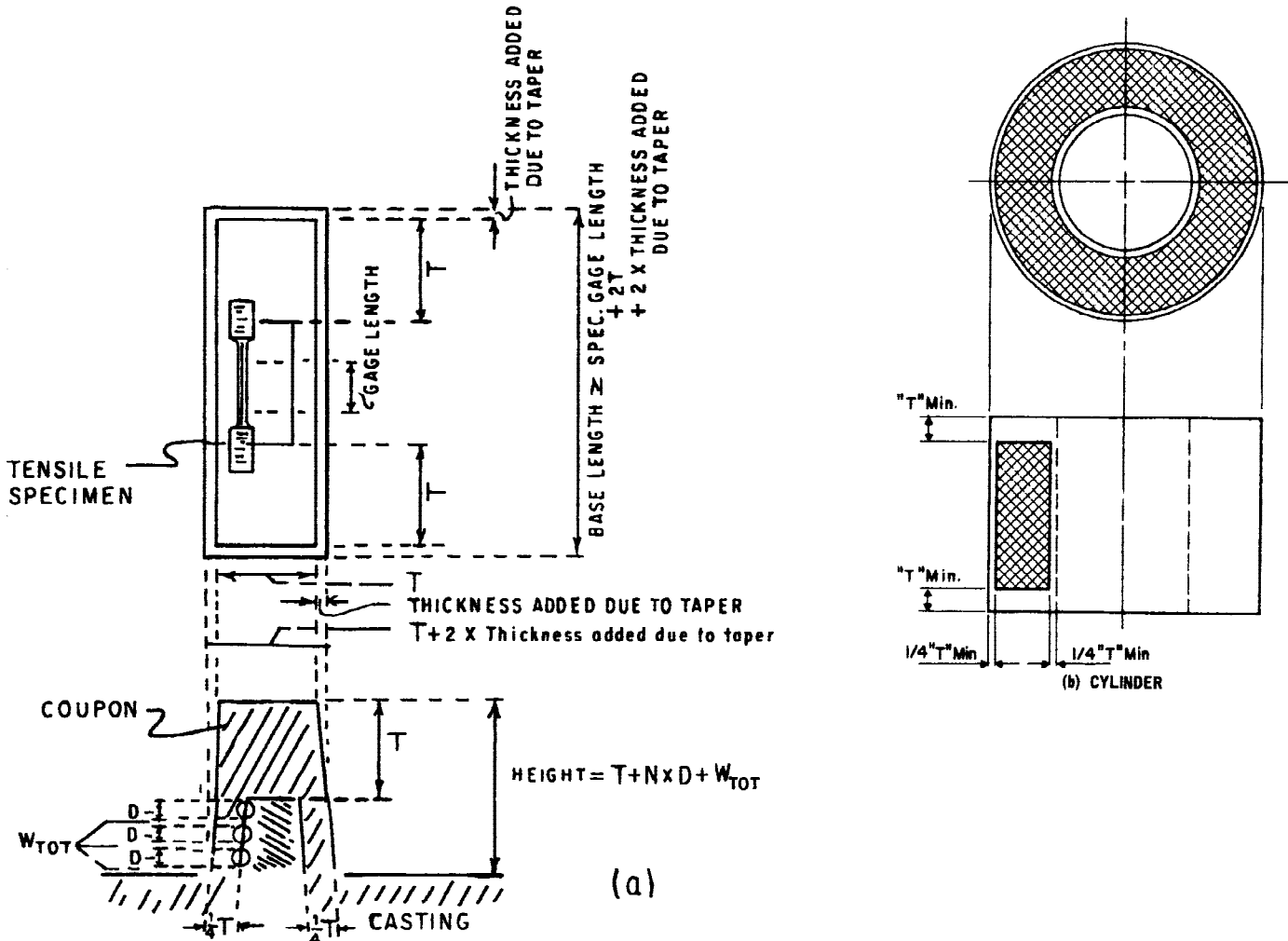

Minimum length of the base — Specimen gage length + $2 \times T$ + $2 \times$ the thickness due to the taper.
 Minimum width of the base — $T + 2 \times$ the thickness added due to the taper.
 Minimum height — $T + N \times D + W_{TOT}$.

The taper is to be selected by the producer for ease of drawing the pattern from the mold.

where:

N = number of specimens to be cut from one side of the coupon,

D = diameter of the specimens, and

W_{TOT} = total width of metal required to remove the coupon from the casting, and to machine specimens from the coupon.

NOTE—Longitudinal axis and gage length of test specimen must be within shaded zone.

FIG. S26.1 Specimen from Casting

ASTM A 703/A 703M – 02

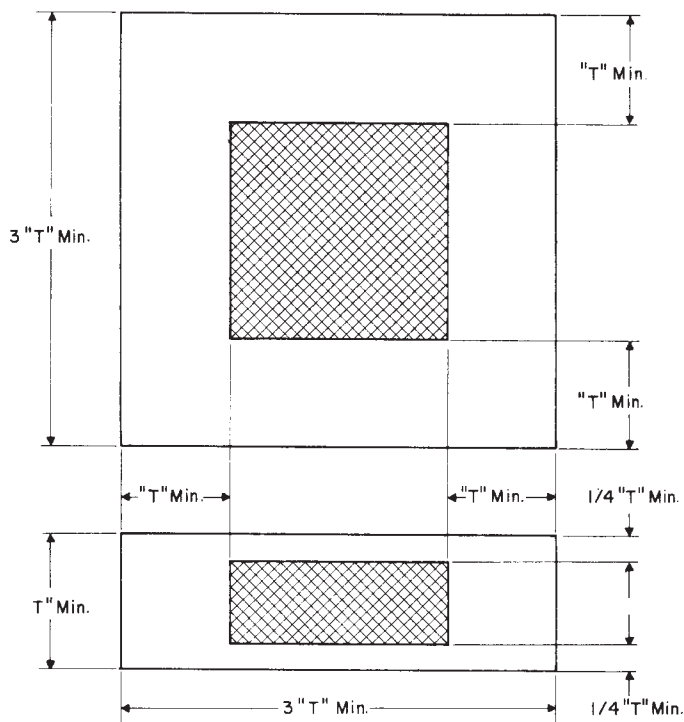

NOTE 1—Longitudinal axis and gage length of test specimen must be within cross-hatched zone.

FIG. S26.2 Separately Cast Block

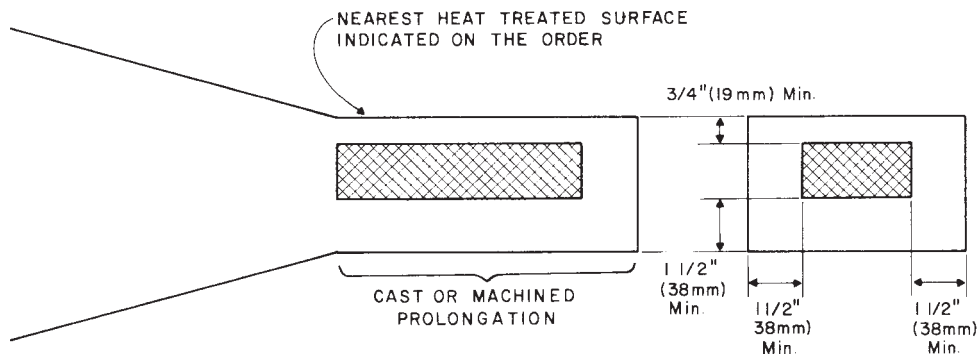

NOTE 1—Longitudinal axis and gage length of test specimen must be within cross-hatched zone.

FIG. S26.3 Prolongation Test Specimen

surfaces (see Fig. S26.4). When thermal insulation is used, it shall be applied adjacent to the casting surface where the test specimens are to be removed. The producer shall demonstrate that the cooling rate of the test specimen location is no faster than that of specimens taken by the method described in S26.3.1

S27. Hot Isostatic Pressing (HIPing)

S27.1 Castings shall be processed by Hot Isostatic Pressing (HIPing). The processing parameters for the HIPing process may be subject to an agreement between the manufacturer and purchaser.

S28. Cleaning of Stainless Steels

S28.1 Final cleaning of the casting surfaces shall be performed in accordance with one of the cleaning methods in

Practice A 380 or Specification A 967 as agreed upon between the purchaser and supplier. Acceptance testing shall be subject to agreement between the purchaser and supplier.

S29. Heat Treatment in the Working Zone of a Surveyed Furnace

S29.1 Castings shall be heat treated in the working zone of a furnace that has been surveyed in accordance with Test Method A 991/A 991M.

S29.2 When castings are heat treated at temperatures above 2000°F [1100°C], then the working zone shall have been established by a survey performed at not more than 25°F [15°C] below nor more than 200°F [110°C] above the minimum heat treatment temperature specified for the grade. If a minimum heat treatment temperature is not specified for the grade, then the survey temperature shall be not more than 50°F

ASTM A 703/A 703M – 02

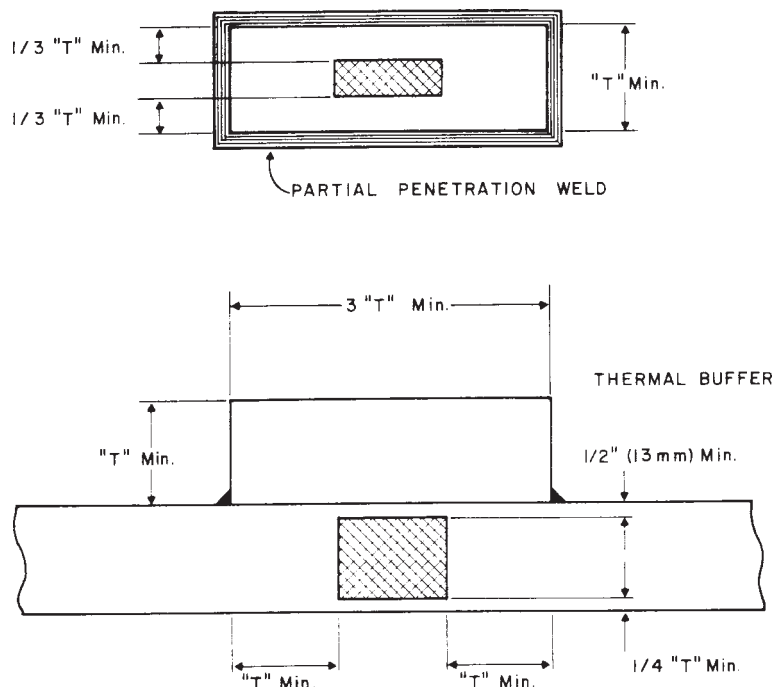

NOTE 1—Longitudinal axis and gage length of test specimen must be within cross-hatched zone.
FIG. S26.4 Thermal Buffer Pads

[30°C] below nor more than 175°F [100°C] above the furnace set point used.

APPENDIXES

(Nonmandatory Information)

X1. ALLOY DESIGNATIONS FOR CAST STAINLESS STEELS

X1.1 Cast stainless steels are usually specified on the basis of composition using the alloy designation system established by the Alloy Casting Institute (ACI). The ACI designations, for example, CF8M, have been adopted by ASTM and are preferred for cast alloys over the designations used by the American Iron and Steel Institute for similar wrought steels.

X1.2 This nomenclature system has served successfully to accommodate changes in old alloys and to designate new ones.

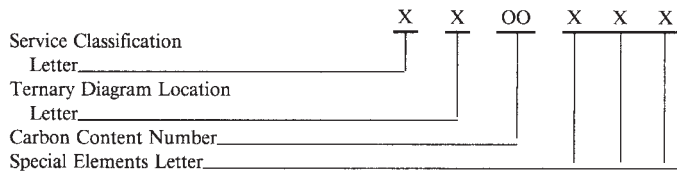

X1.2.1 *Service Classification Letter*—The first letter of the cast stainless steel designation system identifies the intended service application of the alloy. The letter C indicates corrosion-resistant service, and the letter H indicates the heat-resistant service at and above 1200°F [649°C].

X1.2.2 *Ternary Diagram Location Letter*—The second let-

ter indicates the approximate location of the nickel and chromium contents of the alloy grade on the FeCrNi ternary diagram shown in Fig. X1.1.

X1.2.3 *Carbon Content Number*—For C service classifications, this single or dual digit numeral represents the maximum carbon content in units of 0.01 %. For H service classifications, this number represents the midpoint of the range of carbon content in terms of 0.01 % with a ±0.05 % limit.

X1.2.4 *Special Elements Letter*—Additional letters following the numeral represent special chemical elements in the alloy grade, such as M for molybdenum, C for columbium, Cu for copper, W for tungsten. There are two exceptions; the letter A indicates “Controlled Ferrite,” and the letter F indicates “Free Machining.”

X1.3 In Fig. X1.1, unlettered NiCr ranges are associated with the nearest lettered location. They may be the result of differences between corrosion and heat-resistant types or because of the influence of additional elements: for example, the precipitation hardening grade CB-7Cu.

ASTM A 703/A 703M – 02

LOCATION OF ACI ALLOY TYPES

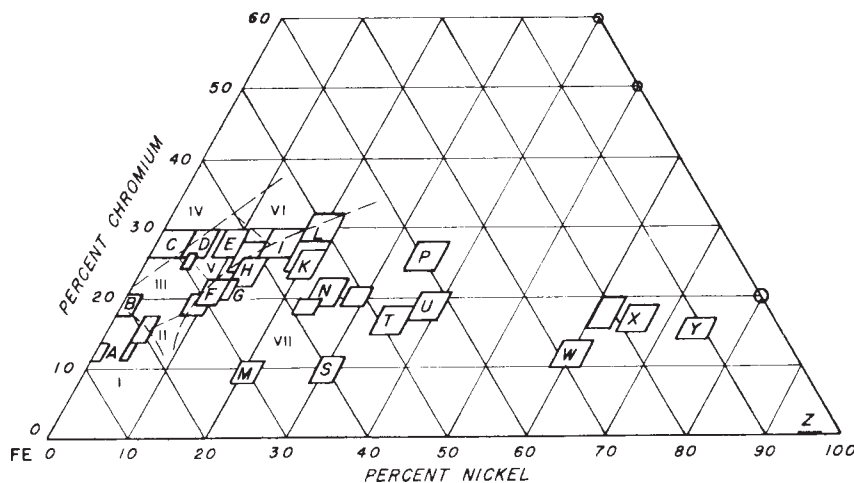

NOTE 1—The approximate areas of microstructures to be expected at room temperature are indicated as follows:

- I—Martensite
- II—Martensite and untransformed austenite
- III—Ferrite plus martensite and untransformed austenite
- IV—Ferrite
- V—Ferrite plus austenite
- VI—Ferrite plus austenite plus sigma
- VII—Austenite

Carbides also may be present depending on carbon content and thermal history.

FIG. X1.1 Letters Assigned to Chromium and Nickel Ranges in ACI Designation System

X2. ADDITION OF NEW GRADES TO PRODUCT SPECIFICATIONS COVERED BY A 703/A 703M

X2.1 Data should be provided from a minimum of ten production heats. This data should include:

X2.1.1 Chemical composition.

X2.1.2 Mechanical properties, as applicable to the product specification being cited. These may include, but are not limited, to the following:

- X2.1.2.1 Ultimate tensile strength,
- X2.1.2.2 Yield strength or yield point,
- X2.1.2.3 Elongation,
- X2.1.2.4 Reduction of area,
- X2.1.2.5 Hardness, and

X2.1.2.6 Impact properties (Charpy V-Notch).

X2.1.3 The test coupon size from which the test specimens were removed, stated for each test.

X2.1.4 Heat treatment requirements.

X2.1.5 Welding procedure. (It is desired that the welding be performed with commercially available consumables.)

X2.1.6 Whether the material is covered by any patents, and if so, the expiration dates of those patents.

X2.2 The inclusion of the proposed material should be supported by written request from at least one purchaser or user indicating the need for the new grade.

**NOTICE: This standard has either been superseded and replaced by a new version or discontinued.
Contact ASTM International (www.astm.org) for the latest information.**



A 703/A 703M – 02

SUMMARY OF CHANGES

Committee A01 has identified the location of selected changes to this standard since the last issue (D 703/D 703M – 01b) that may impact the use of this standard.

(1) Revised S20 to make the criteria for documenting weld repairs subject to agreement between manufacturer and producer.

ASTM International takes no position respecting the validity of any patent rights asserted in connection with any item mentioned in this standard. Users of this standard are expressly advised that determination of the validity of any such patent rights, and the risk of infringement of such rights, are entirely their own responsibility.

This standard is subject to revision at any time by the responsible technical committee and must be reviewed every five years and if not revised, either reapproved or withdrawn. Your comments are invited either for revision of this standard or for additional standards and should be addressed to ASTM International Headquarters. Your comments will receive careful consideration at a meeting of the responsible technical committee, which you may attend. If you feel that your comments have not received a fair hearing you should make your views known to the ASTM Committee on Standards, at the address shown below.

This standard is copyrighted by ASTM International, 100 Barr Harbor Drive, PO Box C700, West Conshohocken, PA 19428-2959, United States. Individual reprints (single or multiple copies) of this standard may be obtained by contacting ASTM at the above address or at 610-832-9585 (phone), 610-832-9555 (fax), or service@astm.org (e-mail); or through the ASTM website (www.astm.org).