



## Standard Specification for Cast Iron Soil Pipe and Fittings<sup>1</sup>

This standard is issued under the fixed designation A 74; the number immediately following the designation indicates the year of original adoption or, in the case of revision, the year of last revision. A number in parentheses indicates the year of last reapproval. A superscript epsilon (ε) indicates an editorial change since the last revision or reapproval.

*This standard has been approved for use by agencies of the Department of Defense.*

### 1. Scope

1.1 This specification covers cast iron soil pipe and fittings for use in gravity flow applications. It establishes standards covering material, principal dimensions, and dimensional tolerances for extra heavy and service cast iron soil pipe and fittings. These pipe and fittings are not intended for pressure applications as the selection of the proper size for drain, waste, vent, and storm drain systems allows free air space for gravity drainage.

1.2 This specification covers pipe and fittings of the following patterns and, when so designated, shall apply to any other patterns that conform with the requirements given herein.

#### 1.2.1 Pipe:

Extra heavy, 5 ft (1.5 m), 10 ft (3.0 m) lengths	Tables 1, 2
Service, 5 ft, 10 ft	1, 2
Outside dimensions (for detailing)	X1.1

#### 1.2.2 Fittings:

¼ bends; long ¼ bends	Tables 3, 4
¼ bends, long low-hub	5
¼ bends, low heel; high heel	6, 7
¼ bends, short sweep; long sweep	8
¼ bends, reducing long sweep	9
½ bends	10
⅝ bends	10
¾ bends; long ¾ bends	11
⅞ bends	11
Y branches	12, 13
Y branches, cleanout on main	14
Y branches, cleanout on branch	15
Y branches, inverted	16
Y branches, combination ⅝ bends, single	17
Y branches, combination ⅝ bends, double	17
Y branches, combination ¾ bends, cleanout	18
Y branches, upright	19
Sanitary T branches, single	20
Sanitary T branches, double	20

Sanitary T branches, cleanout	Tables 21
Tapped sanitary T branches, single	22
Tapped sanitary T branches, double	22
T branches, single and double	23
Tapped T branches, single	24
Tapped T branches, double	24
Horizontal twin tapped T	25
T branches, cleanout	26
Vent branches, single	27
Offsets, ⅙ bend	28
Double hubs	29
Long double hubs	29
Reducers	30
Increases	31, 32
S traps	33
P traps	34, 35
Deep seal P traps	36
Running traps	37
Screw plugs (brass)	38
Blind plugs	39
Iron-body ferrules	40
Side inlets	Fig. 3
Closet bends	41
Tapping bosses	42

1.3 The values stated in inch-pound units are to be regarded as the standard. The values given in parentheses are for information only.

### 2. Referenced Documents

#### 2.1 ASTM Standards:

- A 48 Specification for Gray Iron Castings<sup>2</sup>
- A 438 Test Method for Transverse Testing of Gray Cast Iron<sup>2</sup>
- A 644 Terminology Relating to Iron Castings<sup>2</sup>
- E 8 Test Methods for Tension Testing of Metallic Materials<sup>3</sup>
- E 23 Test Methods for Notched Bar Impact Testing of Metallic Materials<sup>3</sup>

#### 2.2 Federal Standard:

- Fed. Std. No. 123 Marking for Shipment (Civil Agencies)<sup>4</sup>

#### 2.3 Military Standard:

<sup>1</sup> This specification is under the jurisdiction of ASTM Committee A04 on Iron Castings and is the direct responsibility of Subcommittee A04.12 on Pipes and Tubes.

Current edition approved Jan. 10, 1998. Published September 1998. Originally published as A 74 – 17 T. Last previous edition A 74 – 96.

<sup>2</sup> *Annual Book of ASTM Standards*, Vol 01.02.

<sup>3</sup> *Annual Book of ASTM Standards*, Vol 03.01.

<sup>4</sup> Available from Standardization Documents Order Desk, Bldg. 4 Section D, 700 Robbins Ave., Philadelphia, PA 19111-5094, Attn: NPODS.

MIL-STD-129 Marking for Shipment and Storage<sup>4</sup>

2.4 *ANSI Standard:*

B1.20.1 Pipe Threads<sup>5</sup>

### 3. Materials and Manufacture

3.1 The pipe and fittings shall be iron castings suitable for installation and service for sanitary, storm drain, waste, and vent piping applications. They shall meet all applicable requirements and tests given herein.

3.2 The castings shall be made of cast iron, produced by an established commercial method that provides adequate control over chemical and physical properties. Cast iron is a generic term for a series of alloys as defined in Terminology A 644 and includes gray iron as well as ductile iron. The castings shall be sound, true to pattern, and of compact close grain that permits drilling and cutting by ordinary methods. The interior surface shall be reasonably smooth and free from defects which would make the castings unfit for the use for which they are intended.

### 4. Mechanical Properties

4.1 *Mechanical Tests for Gray Iron*—When requested, tests shall be made to determine mechanical properties of the gray iron used in the manufacture of gray iron soil pipe and fittings. Either transverse (flexure) test bars, or tension test specimens shall be employed.

4.1.1 *Transverse Bend Test*—The breaking load shall be not less than 1750 lb (7800 N), and the deflection at the point of application of the load shall be not less than 0.20 in. (5.1 mm).

4.1.2 *Tensile Strength Test*—The tensile strength shall be not less than 21 000 psi (145 MPa).

### 5. Dimensions and Permissible Variations

#### 5.1 *Pipe:*

5.1.1 Single-hub pipe shall have a hub at one end and a spigot at the other. Double hub pipe shall have a hub at each end. Hubs shall have lead grooves. The inner end of hub shall be either with or without a centering recess, all combinations of which shall make a satisfactory leakproof joint. Hub and barrel shall be cast in one piece (see Fig. 1).

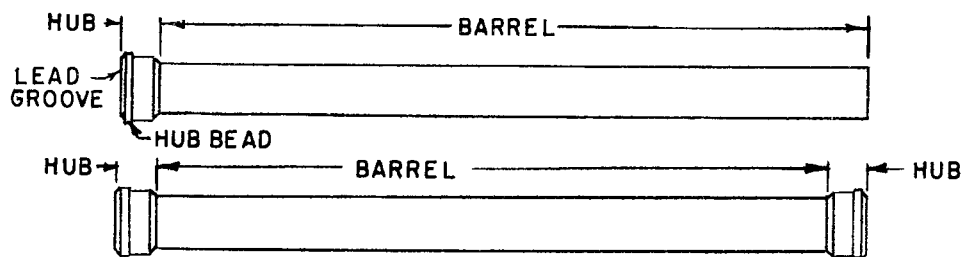

**FIG. 1 Single-Hub and Double-Hub Cast Iron Soil Pipe Laying Lengths**

5.1.2 Single-hub pipe shall be of 2½-ft (0.76-m), 3½-ft (1.07-m), 5-ft (1.5-m), and 10-ft (3.0-m) nominal laying lengths. The laying length shall be as shown in Table 1 and shall be within the tolerances on laying length specified in

Table 2. Double-hub pipe shall be of the same overall length as single-hub pipe of the same size. Its laying length shall be 5 ft minus the two telescoping lengths (dimension *Y*), or 10 ft minus the telescoping length (dimension *Y*). Other dimensions shall be as specified in Table 1 as applicable, and be within the tolerances specified in Table 2. The dimensions shall apply to pipe before any coating is applied.

5.1.3 Pipe shall be straight to the extent that any deflections in the barrel of a 2½-ft, 3½-ft, and 5-ft length of pipe shall not exceed ¼ in. (6.4 mm) for sizes 4 in. (102 mm) and larger, and shall not exceed ⅝ in. (7.9 mm) for smaller sizes: for 10-ft lengths, deflections in the barrel shall not exceed ½ in. (12.7 mm) for sizes 4 in. and larger, nor exceed ⅝ in. (15.9 mm) for smaller sizes.

#### 5.2 *Fittings:*

5.2.1 *Dimensions of Fittings*—All fittings shall conform to the dimensions specified for hub and spigot ends in Table 1 and Table 2, as applicable. Fittings of the patterns specified herein shall conform to the applicable dimensions in Tables 3-42 inclusive, and to the tolerances in Table 2. Other patterns (Note 1) shall conform to Table 1, as applicable, for hub and spigot dimensions, and for wall thickness throughout, and to dimension *R'*, Tables 20-22, for the minimum radius of any drainage inlets that such fittings may provide. All fittings shall have spigot ends of sufficient length to provide adequate room for making leakproof joints. All dimensions given herein shall apply to fittings before any coating is applied.

NOTE 1—Such as, for example, fittings known in the trade as “specials,” when designated as being in conformity with this specification.

5.2.2 *Water Seal and Traps*—Traps shall have water seals as follows:

Trap Size, in. (mm)	Minimum Water seal, in. (mm)
2 (50)	2 (50)
3 to 6 (80 to 150), incl	2½ (64)
8 to 12 (200 to 300), incl	3 (80)

5.2.3 *Ends of Fittings*—Hubs shall have lead grooves. The inner end of hub may be either with or without a centering

recess, all combinations of which shall make a satisfactory joint. Tapped openings shall conform to 5.2.4. It is permissible to increase the wall thickness on the inside surface of fittings having one or more plain ends. The increased thickness shall not reduce the minimum *B* dimension in Table 1 in excess of 0.06 in. and shall not extend more than 4 ¼ in. from the plain end. The increased thickness shall be tapered and offer no

<sup>5</sup> Available from American National Standards Institute, 11 West 42nd Street, 13th Floor, New York, NY 10036.

 **A 74**

obstruction to flow. Inside diameters complying with service4 or extra heavy inside diameters shall be permitted on 15 in.-sized only.

5.2.4 *Pipe Threads*—Screw plugs and tapped openings in fittings shall have American Standard taper pipe threads. The threads shall be in accordance with the American National Standard for Pipe Threads, B2.1, or with the National Bureau of Standards Handbook 28; Screw Thread Standards for Federal Services, of the current issue.

5.2.5 Internal threads shall be chamfered at the entering end approximately to the major diameter of the thread, at an angle of approximately 45° with the axis of the thread, and the entering end of external threads shall be similarly chamfered approximately to be minor diameter of the thread, for easy entrance in making a joint and for protection of the thread. The chamfer shall be concentric with the thread and shall be included in measurements of thread length.

## 6. Methods of Specifying Fittings

6.1 *Method of Specifying Sizes of Fittings of More than One Size*—The sizes are designated by the order of listing, as follows:

- 6.1.1 Branch and tapped fittings:
  - 6.1.1.1 Size of run (Note 2), and
  - 6.1.1.2 Size of branch.
- 6.1.2 Reducers, increasers, and offset fittings:
  - 6.1.2.1 Size of inlet or run (Note 2),
  - 6.1.2.2 Size of outlet or offset distance,
  - 6.1.2.3 Length, if supplied in more than one length.

NOTE 2—The run is that portion of the fitting which forms part of the main drain, waste or vent line. The spigot end is ordinarily the outlet.

6.2 *Method of Specifying Hand of Fittings with Side Inlets and Outlets*—When placed in the position described below, if the side inlet or outlet appears on the right, it is a right-hand fitting; if on the left, it is a left-hand fitting.

6.2.1 *Bends and Offsets*—Place the fitting with hub facing toward the observer and the spigot end lower than the hub.

6.2.2 *Branch Fittings*—Place the branch toward the observer and the spigot end lower than the hub.

6.2.3 *Traps*—Place in the position in which the trap is installed, with the hub toward the observer.

6.2.4 The fittings shown in Fig. 2 have right-hand inlet or cleanout. Left-hand fittings have these openings on the side opposite to that shown. For details of side inlets, see Fig. 3.

## 7. Coating

7.1 The pipe and fittings shall be uniformly coated with a material suitable for the purpose, that is adherent, not brittle, and without a tendency to scale. The coating shall be evenly and smoothly applied to all surfaces except threaded openings.

## 8. Sampling

8.1 Chemical analyses shall be made regularly and at sufficiently close intervals for adequate determinations of the significant chemical constituents of the cast iron.

## 9. Test Methods

9.1 *Gray Iron:*

9.1.1 *Transverse Bend Test*—The transverse bend test shall be performed in accordance with the requirements of Test Method A 438. The test bar shall be 1.2 in. (30.5 mm) in diameter by 21 in. in length, and loaded at a point midway between supports 18 in. (457 mm) apart.

9.1.2 *Tensile Strength Test*—Test bars shall be cast in accordance with the requirements of Specification A 48. The tensile strength shall be determined in accordance with Test Methods E 8. Using Specimen 2, Fig. 6, Standard Test Specimen for Cast Iron.

## 10. Inspection

10.1 *Inspection and Test by the Manufacturer*—Pipe and fittings shall be thoroughly inspected by the manufacturer before shipment. On the sample pieces selected for inspection, the inside diameter of the hub and barrel and the outside diameter of the spigot end shall be checked by suitable gages. Fittings shall be suitably inspected for soundness and brittleness.

## 11. Certification

11.1 Upon request of the purchaser, the manufacturer shall be prepared to certify that his product conforms to the requirements of this specification.

## 12. Product Marking

12.1 Each length of pipe and each fitting shall be plainly marked with the country of origin, the manufacturer's initials or registered trademark by which the manufacturer can be readily identified after installation, and with letters to indicate the proper classification, as follows:

XH	Extra Heavy
SV	Service

The marking shall be cast, stenciled, or otherwise applied on the pipe so as to be clear and legible after installation. The marking shall be cast on fittings and shall be clear and legible after installation and located away from the spigot end so as not to interfere with proper joining upon installation.

## 13. Packaging and Package Marking

13.1 *Government Procurement*—Unless otherwise specified in the contract, the material shall be packaged in accordance with the supplier's standard practice which will be acceptable to the carrier at lowest rates. Containers and packing shall comply with Uniform Freight Classification Rules<sup>6</sup> or National Motor Freight Classification Rules.<sup>7</sup> Marking for shipment of such material shall be in accordance with Fed. Std. No. 123 for civil agencies and MIL-STD-129 for military agencies.

## 14. Keywords

14.1 cast iron; hub and spigot pipe; pipe; soil pipe

<sup>6</sup> Available from The Uniform Classification Commission, Room 1106, 222 S. Riverside Plaza, Chicago, IL 60606.

<sup>7</sup> Available from National Motor Freight Inc., 1616 P. St., N.W., Washington, DC 20036.

ASTM A 74

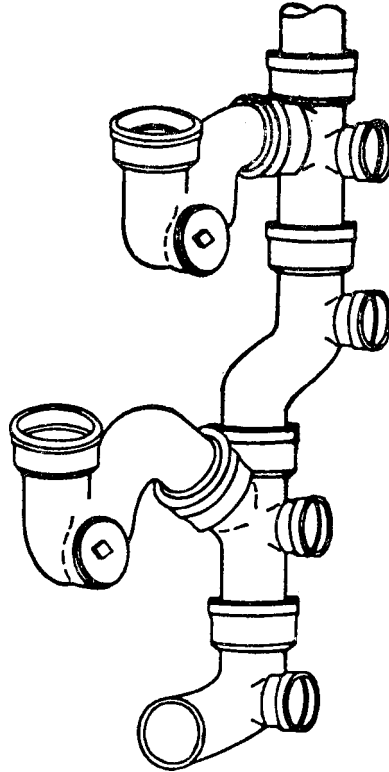

**FIG. 2 Fittings with Right-Hand Inlet or Cleanout**

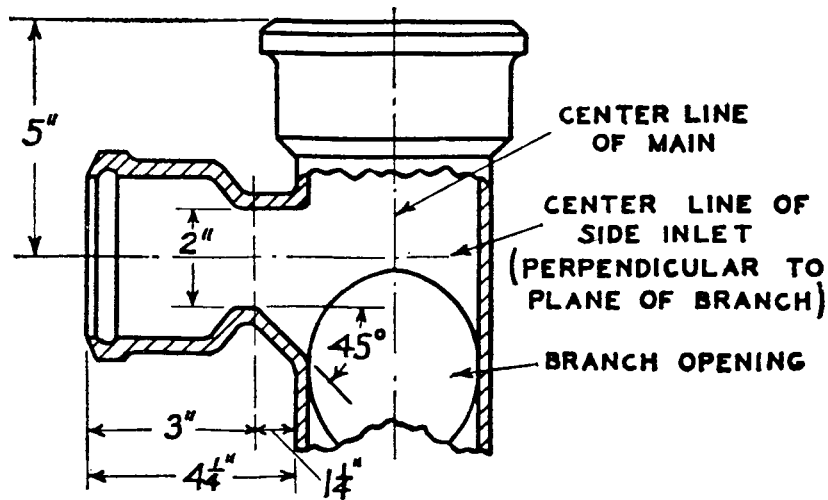

NOTE 1—1 in. = 25.4 mm.

NOTE 2—Dimensions and location of 2-in. side inlet for single or double sanitary T branches and Y branches are shown above. Single and double sanitary T branches and single and double Y branches with 2-in. side inlets are standard in the following sizes only: 4 by 3 by 2-in.; 4 by 4 by 2-in.; 5 by 4 by 2-in.; 6 by 4 by 2-in.

**FIG. 3 Dimensions and Locations for 2-in. Side Inlets**



**TABLE 1 Dimensions of Hubs, Spigots, and Barrels for Extra-Heavy and Service Cast Iron Soil Pipe and Fittings, in.**

NOTE 1—1 in. = 25.4 mm; 1 ft = 0.3 m throughout tables.

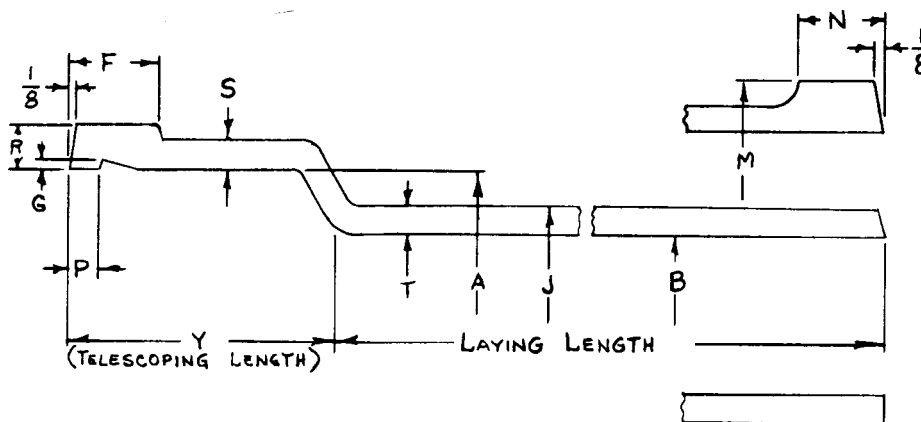

Extra-Heavy Cast Iron Soil Pipe and Fittings:

Size <sup>A</sup> Availability	Inside Diameter of Hub <sup>B</sup>	Outside Diameter of Barrel <sup>B</sup>	Telescoping Length <sup>B</sup>	Inside Diameter of Barrel <sup>B</sup>	Thickness of Barrel <sup>B</sup>	
	A	J	Y	B	T	
					Nom	Min
2*	3.06[77.72]	2.38[60.45]	2.50[63.5]	2.00[50.8]	0.19[4.83]	0.16[4.06]
3*	4.19[106.43]	3.50[88.9]	2.75[69.85]	3.00[76.2]	0.25[6.35]	0.22[5.59]
4*	5.19[131.83]	4.50[114.3]	3.00[76.2]	4.00[101.6]	0.25[6.35]	0.22[5.59]
5*	6.19[131.83]	5.50[139.7]	3.00[76.2]	5.00 [127]	0.25[6.35]	0.22[5.59]
6*	7.19[182.63]	6.50[165.1]	3.00[76.2]	6.00[152.4]	0.25[6.35]	0.22[5.59]
8*	9.50[241.30]	8.62[218.5]	3.50[88.9]	8.00[203.2]	0.31[7.87]	0.25[6.35]
10*	11.62[295.15]	10.75[273.05]	3.50[88.9]	10.00 [254]	0.37[9.40]	0.31[7.87]
12*	13.75[349.25]	12.75[323.85]	4.25[107.95]	12.00[304.8]	0.37[9.40]	0.31[7.87]
15*	16.95[430.53]	15.88[403.35]	4.25[107.95]	15.00 [381]	0.44[11.18]	0.38[9.65]

Size <sup>A</sup>	Thickness of Hub		Width of Hub Bead <sup>B,C</sup>	Distance from Lead Groove to End, Pipe and Fittings <sup>B</sup>	Depth of Lead Groove	
	Hub Body	Over Bead			G (min)	G (max)
	S (min)	R (min)	F	P		
2	0.18[4.57]	0.37[9.40]	0.75[19.05]	0.22[5.59]	0.10[2.54]	0.19[4.83]
3	0.25[6.35]	0.43[10.92]	0.81[20.57]	0.22[5.59]	0.10[2.54]	0.19[4.83]
4	0.25[6.35]	0.43[10.92]	0.88[22.35]	0.22[5.59]	0.10[2.54]	0.19[4.83]
5	0.25[6.35]	0.43[10.92]	0.88[22.35]	0.22[5.59]	0.10[2.54]	0.19[4.83]
6	0.25[6.35]	0.43[10.92]	0.88[22.35]	0.22[5.59]	0.10[2.54]	0.19[4.83]
8	0.34[8.64]	0.59[14.99]	1.19[30.23]	0.38[9.65]	0.15[3.81]	0.22[5.59]
10	0.40[10.16]	0.65[16.51]	1.19[30.23]	0.38[9.65]	0.15[3.81]	0.22[5.59]
12	0.40[10.16]	0.65[16.51]	1.44[36.54]	0.47[11.94]	0.15[3.81]	0.22[5.59]
15	0.46[11.68]	0.71[18.03]	1.44[36.54]	0.47[11.94]	0.15[3.81]	0.22[5.59]

Service Cast Iron Soil Pipe:

Size <sup>A</sup> Availability <sup>B</sup>	Inside Diameter of Hub <sup>B</sup>	Outside Diameter of Barrel <sup>D</sup>	Telescoping Length <sup>D</sup>	Inside Diameter of Barrel <sup>D</sup>	Thickness of Barrel <sup>D</sup>	
	A	J	Y	B	T	
					Nom	Min
20	2.94[74.68]	2.30[58.42]	2.50[63.5]	1.96[49.78]	0.17[4.32]	0.14[3.56]
30	3.94[100.08]	3.30[83.82]	2.75[69.85]	2.96[75.18]	0.17[4.32]	0.14[3.56]
40	4.94[125.48]	4.30[109.22]	3.00 [76.2]	3.94[100.08]	0.18[4.57]	0.15[3.81]
50	5.94[150.88]	5.30[134.62]	3.00[76.2]	4.94[125.48]	0.18[4.57]	0.15[3.81]
60	6.94[176.28]	6.30[160.02]	3.00[76.2]	5.94[150.88]	0.18[4.57]	0.15[3.81]
80	9.25[234.95]	8.38[212.85]	3.50[88.9]	7.94[201.68]	0.23[5.84]	0.17[4.32]
100	11.38[289.05]	10.50[266.70]	3.50[88.9]	9.94[252.48]	0.28[6.86]	0.22[5.59]
120	13.50[342.9]	12.50[317.5]	4.25[107.95]	11.94[303.28]	0.28[6.86]	0.22[5.59]
150	16.95[430.53]	15.88[403.35]	4.25[107.95]	15.16[385.06]	0.36[9.14]	0.30[7.62]



**TABLE 1** *Continued*

Size <sup>A</sup>	Thickness of Hub		Width of Hub Bead <sup>D</sup>	Distance from Lead Groove to End, Pipe and Fittings <sup>B</sup>	Depth of Lead Groove	
	Hub Body	Over Bead			G (min)	G (max)
	S (min)	R (min)	F (min)	P		
2	0.13[3.30]	0.34[8.64]	0.75 (0.63) [19.05] (16.00)	0.22[5.59]	0.10[2.54]	0.19[4.83]
3	0.16[4.06]	0.37[9.40]	0.81 (0.63) [20.57] (16.00)	0.22[5.59]	0.10[2.54]	0.19[4.83]
4	0.16[4.06]	0.37[9.40]	0.88 (0.63) [22.35] (16.00)	0.22[5.59]	0.10[2.54]	0.19[4.83]
5	0.16[4.06]	0.37[9.40]	0.88 (0.63) [22.35] (16.00)	0.22[5.59]	0.10[2.54]	0.19[4.83]
6	0.18[4.57]	0.37 [9.40]	0.88 (0.63) [22.35] (16.00)	0.22[5.59]	0.10[2.54]	0.19[4.83]
8	0.19[4.83]	0.44[11.26]	1.19 (1.06) [30.23] (26.92)	0.38[9.65]	0.15[3.81]	0.22[5.59]
10	0.27[6.86]	0.53[13.46]	1.19 (1.06) [30.23] (26.92)	0.38[9.65]	0.15[3.81]	0.22[5.59]
12	0.27[6.86]	0.53[13.46]	1.44 (1.31) [36.58] (33.27)	0.47[11.94]	0.15[3.81]	0.22[5.59]
15	0.30[7.62]	0.58[14.73]	1.44 (1.31)[36.58] (33.27)	0.47[11.94]	0.15[3.81]	0.22[5.59]

<sup>A</sup> Nominal inside diameter.

\* Indicates this item is made in extra heavy.

<sup>B</sup> For tolerances, see Table 2.

<sup>C</sup> Hub ends and spigot ends can be made with or without draft.

<sup>D</sup> Hub ends and spigot ends shall be permitted to be made with or without draft.

O Indicates this item is made in service weight.

### SUPPLEMENTARY REQUIREMENTS

The following supplementary requirements shall be applied only when specified by the purchaser. Details of the supplementary requirements shall be agreed upon by the manufacturer and the purchaser. The specified tests shall be performed by the manufacturer prior to shipment of the castings.

#### S1. Leak Tests on Pipe

S1.1 Sample lengths of pipe shall be checked for leaks by subjecting them to an internal hydrostatic pressure of 20 psi (138 kpa).

S1.2 Samples shall be taken at substantially regular intervals in the course of production so as to be representative of the

material delivered, and shall consist of at least 20 % of the lengths ordered in each size. For every sample which leaks, four or more additional samples shall be taken. Each additional sample shall be representative of the same material as that of the defective sample.

S1.3 Pipe which leak shall be rejected.

**ASTM A 74**

**TABLE 2 Dimensional Tolerances for Extra-Heavy and Service Cast Iron Soil Pipe and Fittings, in.**

NOTE 1—1 in. = 25.4 mm.

NOTE 2—The tolerances set forth in Table 2 are intended for pipe and fittings designed for use with lead and oakum joints; however, these same tolerances shall apply to pipe and fittings designed for use with a compression type gasket joint.

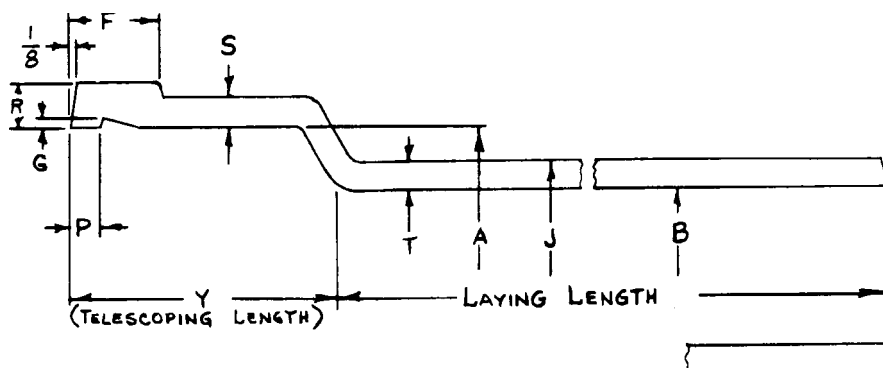

Size <sup>A</sup>	Outside Diameter of Barrel	Inside Diameter of Barrel	Tele-scoping Length	Laying Length				
	A'	J	B	Y	Pipe, 2½-, 3½-, 5-ft Lengths	Pipe, 10-ft Lengths	Fittings	
							Regular	Extra Long <sup>B</sup>
2	±0.06 [1.52]	±0.09[±2.29]	±0.09[±2.29]	±0.06[±1.52]	±¼ [±6.35]	±½ [±12.7]	±⅛ [±3.18]	±⅛ [±1.59]
3	±0.09[2.29] -0.06 [1.52]	±0.09[±2.29]	±0.06[±1.52]	±¼ [±6.35]	±½ [±12.7]	...	±⅛ [±1.59]	
4	+0.09[2.29] -0.06 [1.52]	±0.09[±2.29]	±0.09[±2.29]	±0.06[±1.52]	±¼ [±6.35]	±½ [±12.7]	±⅛ [±3.18]	±⅛ [±1.59]
5	+0.09[2.29] -0.06 [1.52]	±0.09[±2.29]	±0.09[±2.29]	±0.06[±1.52]	±⅕ [±7.94]	±⅝ [±15.88]	±⅜ [±4.76]	±⅜ [±2.38]
6	+0.09 [2.29] -0.06 [1.52]	±0.09[±2.29]	±0.09[±2.29]	±0.06[±1.52]	±⅕ [±7.94]	±⅝ [±15.88]	±⅜ [±4.76]	±⅜ [±2.38]
8	±0.13[3.30]	±0.13[±3.30]	±0.13[±3.30]	±0.13[±3.30]	±⅕ [±7.94]	±⅝ [±15.88]	±⅜ [±4.76]	±⅜ [±2.38]
10	±0.13[3.30]	±0.13[±3.30]	±0.13[±3.30]	±0.13[±3.30]	±⅕ [±7.94]	±⅝ [±15.88]	±⅜ [±4.76]	±⅜ [±2.38]
12	±0.13[3.30]	±0.19[±4.83]	±0.19[±4.83]	±0.19[±4.83]	±⅕ [±7.94]	±⅝ [±15.88]	±⅜ [±4.76]	±⅜ [±2.38]
15	±0.13[3.30]	±0.19[±4.83]	±0.19[±4.83]	±0.19[±4.83]	±⅕ [±7.94]	±⅝ [±15.88]	±⅜ [±4.76]	±⅜ [±2.38]
		Size				Distance from Lead Groove to End, Pipe and Fittings		
						P		
		2				±0.09 [±1.52]		
		3				±0.09 [±1.52]		
		4				±0.09 [±1.52]		
		5				±0.09 [±1.52]		
		6				±0.09 [±1.52]		
		8				±0.09 [±1.52]		
		10				±0.09 [±1.52]		
		12				±0.11 [±2.79]		
		15				±0.11 [±2.79]		

<sup>A</sup> Nominal inside diameter.

<sup>B</sup> These tolerances apply to each foot of extra-long fittings in excess of regular laying lengths specified herein.



**ASTM A 74**

**TABLE 3 Dimensions of One-Quarter Bends**

NOTE 1—1 in. = 25.4 mm.

NOTE 2—Dimensions *D* and *X* are laying lengths.

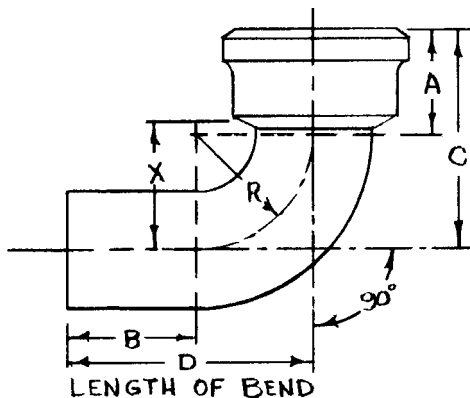

Size, in., Availability <sup>A</sup>	Dimensions in in. <sup>B</sup>					
	A	B	C	D	R	X
2"O	2¾ [70]	3 [76]	5¾ [146]	6 [152]	3 [76]	3¼ [83]
3"O	3¼ [83]	3½ [89]	6¾ [171]	7 [178]	3½ [89]	4 [102]
4"O	3½ [89]	4 [102]	7½ [191]	8 [203]	4 [102]	4½ [114]
5"O	3½ [89]	4 [102]	8 [203]	8½ [216]	4½ [114]	5 [127]
6"O	3½ [89]	4 [102]	8½ [216]	9 [229]	5 [127]	5½ [140]
8"O	4⅞ [105]	5½ [140]	10⅞ [257]	11½ [292]	6 [152]	6⅞ [168]
10"O	4⅞ [105]	5½ [140]	11⅞ [283]	12½ [318]	7 [178]	7⅞ [194]
12"O	5 [127]	7 [178]	13 [330]	15 [381]	8 [203]	8¾ [222]
15"O	5 [127]	7 [178]	14½ [368]	16½ [419]	9½ [241]	10¼ [260]

<sup>A</sup> \* indicates this item is made in extra heavy.

O indicates this item is made in service weight.

<sup>B</sup> For details of hubs and spigots, see Table 1.



**ASTM A 74**

**TABLE 4 Dimensions of Long One-Quarter Bends**

NOTE 1—1 in. = 25.4 mm.

NOTE 2—Dimensions *D* and *X* are laying lengths.

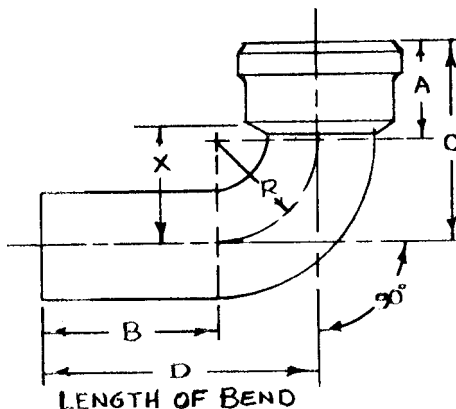

Size, in., Availability <sup>A</sup>	Dimensions in in. <sup>B</sup>					
	A	B	C	D	R	X
2 by 12°O	2¾ [76]	9 [229]	5¾ [146]	12 [305]	3 [76]	3¼[83]
2 by 18°O	2¾ [76]	15 [381]	5¾ [146]	18 [457]	3 [76]	3¼[83]
2 by 24°O	2¾ [76]	21 [533]	5¾ [146]	24 [610]	3 [76]	3¼[83]
3 by 12°O	3¼ [83]	8½[216]	6¾ [171]	12 [305]	3½[89]	4 [102]
3 by 18°O	3¼ [83]	14½[368]	6¾ [171]	18 [457]	3½[89]	4 [102]
3 by 24°O	3¼ [83]	20½[521]	6¾ [171]	24 [610]	3½[89]	4 [102]
4 by 12°O	3½ [89]	8 [203]	7½ [191]	12 [305]	4 [102]	4½[114]
4 by 18°O	3½ [89]	14 [356]	7½ [191]	18 [457]	4 [102]	4½[114]
4 by 24°O	3½ [89]	20 [508]	7½ [191]	24 [610]	4 [102]	4½[114]

<sup>A</sup> \* indicates this item is made in extra heavy.

O indicates this item is made in service weight.

<sup>B</sup> For details of hubs and spigots, see Table 1.

**TABLE 5 Dimensions of Long Low-Hub One-Quarter Bends**

NOTE 1—1 in. = 25.4 mm.

NOTE 2—Dimensions *D* and *X* are laying lengths.

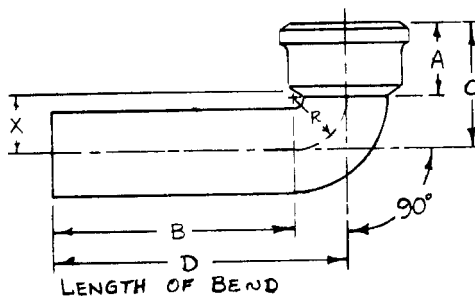

Size, in., Availability <sup>A</sup>	Dimensions in in. <sup>B</sup>					
	A	B	C	D	R	X
4 by 12O	3 [76]	9¼ [235]	5¾ [146]	12 [305]	2¾ [70]	2¾ [70]
4 by 14O	3 [76]	11¼ [286]	5¾ [146]	14 [356]	2¾ [70]	2¾ [70]
4 by 16O	3 [76]	13¼ [337]	5¾ [146]	16 [406]	2¾ [70]	2¾ [70]
4 by 18O	3 [76]	15¼ [387]	5¾ [146]	18 [457]	2¾ [70]	2¾ [70]

<sup>A</sup> O indicates this item is made in service weight.

<sup>B</sup> For details of hubs and spigots, see Table 1.

**ASTM A 74**

**TABLE 6 Dimensions of One-Quarter Bends with Low Heel Inlet**

NOTE 1—1 in. = 25.4 mm.

NOTE 2—Dimensions *D*, *X*, and *X'* are laying lengths

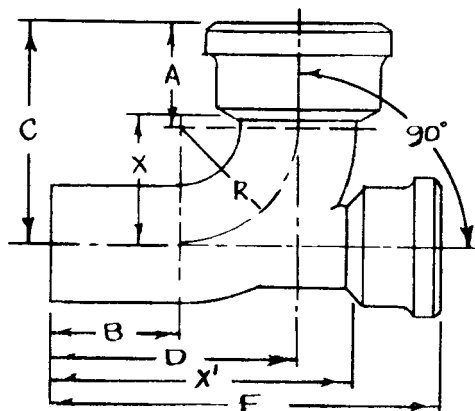

Size, in., Availability <sup>A</sup>	Dimensions in in. <sup>B</sup>								
A	B	C	D	F	R	X	X'		
3 by 2O	3¼ [83]	3½ [89]	6¾ [172]	7 [178]	11½ [292]	3½ [89]	4 [102]	9	[229]
4 by 2*O	3½ [89]	4 [102]	7½ [191]	8 [203]	13 [330]	4 [102]	4½ [114]	10½	[267]
4 by 3*O	3½ [89]	4 [102]	7½ [191]	8 [203]	13¼ [337]	4 [102]	4½ [114]	10½	[267]

<sup>A</sup> \* indicates this item is made in extra heavy.

O indicates this item is made in service weight.

<sup>B</sup> For details of hubs and spigots, see Table 1.

**TABLE 7 Dimensions of High Heel One-Quarter Bends**

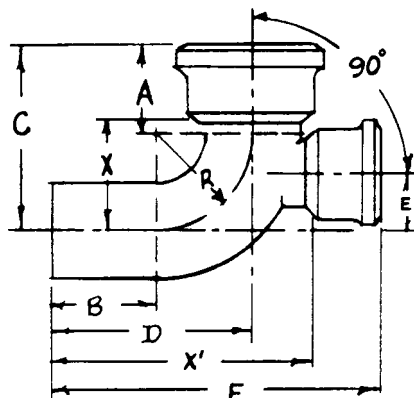

Size, in., Availability <sup>A</sup>	Dimensions in in. <sup>B</sup>									
A	B	C	D	E	F	R	X	X'		
3 by 2*O	3¼ [83]	3½ [89]	6¾ [171]	7 [178]	2¼ [57]	11½ [292]	3½ [89]	4 [102]	9	[229]
4 by 2*O	3½ [89]	4 [102]	7½ [191]	8 [203]	2¾ [70]	13 [330]	4 [102]	4½ [114]	10½	[267]
4 by 3*O	3½ [89]	4 [102]	7½ [191]	8 [203]	2¼ [70]	13¼ [337]	4 [102]	4½ [114]	10½	[267]

<sup>A</sup> \* indicates this item is made in extra heavy.

O indicates this item is made in service weight.

<sup>B</sup> For details of hubs and spigots, see Table 1.

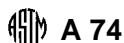

**TABLE 8 Dimensions of Short and Long Sweep Bends**

NOTE 1—1 in. = 25.4 mm.

NOTE 2—Dimensions *D* and *X* are laying lengths.

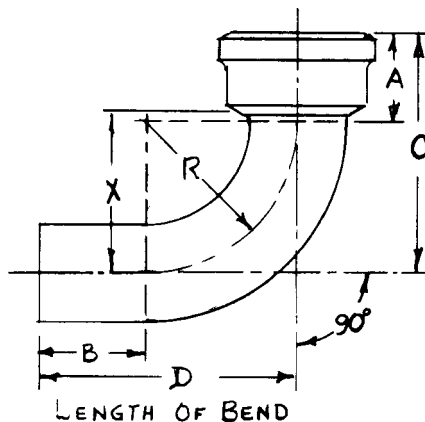

**Short Sweep Bends:**

Size, in.	Dimensions in in. <sup>A</sup>					
	A	B	C	D	R	X
2°O	2¾ [70]	3 [76]	7¾ [197]	8 [203]	5 [127]	5¼ [133]
3°O	3¼ [83]	3½ [89]	8¾ [222]	9 [229]	5½ [140]	6 [152]
4°O	3½ [89]	4 [102]	9½ [241]	10 [254]	6 [152]	6½ [165]
5°O	3½ [89]	4 [102]	10 [254]	10½ [267]	6½ [165]	7 [178]
6°O	3½ [89]	4 [102]	10½ [267]	11 [279]	7 [178]	7½ [191]
8°O	4⅞ [105]	5½ [140]	12⅞ [308]	13½ [343]	8 [203]	8¾ [219]
10°O	4⅞ [105]	5½ [140]	13⅞ [333]	14½ [368]	9 [229]	9¾ [244]
12°O	5 [127]	7 [178]	15 [381]	17 [432]	10 [254]	10¾ [273]
15°O	5 [127]	7 [178]	16½ [419]	18½ [470]	11½ [292]	12¼ [311]

<sup>A</sup>For details of hubs and spigots, see Table 1.

**Long Sweep Bends:**

Size, in., Availability <sup>A</sup>	Dimensions in in. <sup>B</sup>					
	A	B	C	D	R	X
2°O	2¾ [70]	3 [76]	10¾ [273]	11 [279]	8 [203]	8¼ [210]
3°O	3¼ [83]	3½ [89]	11¾ [298]	12 [305]	8½ [216]	9 [229]
4°O	3½ [89]	4 [102]	12½ [318]	13 [330]	9 [229]	9½ [241]
5°O	3½ [89]	4 [102]	13 [330]	13½ [343]	9½ [241]	10 [254]
6°O	3½ [89]	4 [102]	13½ [343]	14 [356]	10 [254]	10½ [267]
8°O	4⅞ [105]	5½ [140]	15⅞ [384]	16½ [419]	11 [279]	11¾ [295]
10°O	4⅞ [105]	5½ [140]	16⅞ [410]	17½ [445]	12 [305]	12¾ [321]
12°O	5 [127]	7 [178]	18 [457]	20 [508]	13 [330]	13¾ [349]
15°O	5 [127]	7 [178]	19½ [495]	21½ [546]	14½ [368]	15¼ [387]

<sup>A</sup>\* indicates this item is made in extra heavy.

O indicates this item is made in service weight.

<sup>B</sup> For details of hubs and spigots, see Table 1.

**ASTM A 74**

**TABLE 9 Dimensions of Reducing Long Sweep Bends**

NOTE 1—1 in. = 25.4 mm.

NOTE 2—Dimensions *D* and *X* are laying lengths.

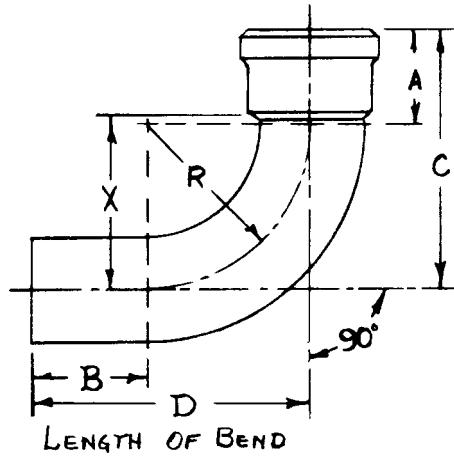

Size, in., Availability <sup>A</sup>	Dimensions in in. <sup>B</sup>					
	<i>A</i>	<i>B</i>	<i>C</i>	<i>D</i>	<i>R</i>	<i>X</i>
3 by 2"O	3 [76]	3½ [89]	11½ [292]	12 [305]	8½ [216]	9 [229]
4 by 3"O	3¼ [83]	4 [102]	12¼ [311]	13 [330]	9 [229]	9½ [241]

<sup>A</sup> \* indicates this item is made in extra heavy.

O indicates this item is made in service weight.

<sup>B</sup> For details of hubs and spigots, see Table 1.



**TABLE 10 Dimensions of One-Fifth and One-Sixth Bends**

NOTE 1—1 in. = 25.4 mm.

NOTE 2—Dimensions *D* and *X* are laying lengths.

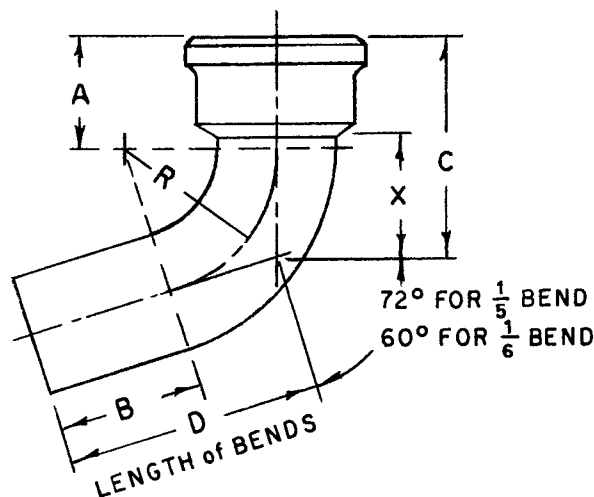

**One-Fifth Bends:**

Size, in. Availability <sup>A</sup>	Dimensions in in. <sup>B</sup>					
	A	B	C	D	R	X
2°O	2¾ [70]	3 [76]	4 <sup>15</sup> / <sub>16</sub> [125]	5 <sup>3</sup> / <sub>16</sub> [132]	3 [76]	2 <sup>1</sup> / <sub>16</sub> [62]
3°O	3¼ [83]	3½ [89]	5 <sup>1</sup> / <sub>4</sub> [148]	6 <sup>1</sup> / <sub>16</sub> [154]	3½ [89]	3 <sup>1</sup> / <sub>16</sub> [78]
4°O	3 ½ [85]	4 [102]	6 <sup>7</sup> / <sub>16</sub> [164]	6 <sup>9</sup> / <sub>16</sub> [176]	4 [102]	3 <sup>3</sup> / <sub>16</sub> [87]
5°O	3½ [89]	4 [102]	6¾ [171]	7¼ [184]	4½ [114]	3¾ [95]
6°O	3½ [89]	4 [102]	7 <sup>1</sup> / <sub>8</sub> [181]	7 <sup>5</sup> / <sub>8</sub> [194]	5 [127]	4 <sup>1</sup> / <sub>8</sub> [105]

<sup>A\*</sup> indicates this item is made in extra heavy.

O indicates this item is made in service weight.

<sup>B</sup>For details of hubs and spigots, see Table 1.

**Long Sweep Bends:**

Size, in., Availability <sup>A</sup>	Dimensions in in. <sup>B</sup>					
	A	B	C	D	R	X
2°O	2¾ [70]	3 [76]	4½ [114]	4¾ [121]	3 [76]	2 [51]
3°O	3¼ [83]	3½ [89]	5¼ [133]	5½ [140]	3½ [89]	2½ [64]
4°O	3½ [89]	4 [102]	5 <sup>3</sup> / <sub>4</sub> [147]	6 <sup>3</sup> / <sub>16</sub> [160]	4 [102]	2 <sup>3</sup> / <sub>16</sub> [71]
5°O	3½ [89]	4 [102]	6 <sup>1</sup> / <sub>8</sub> [156]	6 <sup>5</sup> / <sub>8</sub> [168]	4½ [114]	3 <sup>1</sup> / <sub>8</sub> [79]
6°O	3½ [89]	4 [102]	6 <sup>3</sup> / <sub>8</sub> [161]	6 <sup>7</sup> / <sub>8</sub> [175]	5 [127]	3 <sup>3</sup> / <sub>8</sub> [86]
8°O	4 <sup>1</sup> / <sub>8</sub> [105]	5½ [140]	7 <sup>5</sup> / <sub>8</sub> [194]	9 [229]	6 [152]	4 <sup>1</sup> / <sub>8</sub> [105]
10°O	4 <sup>1</sup> / <sub>8</sub> [105]	5½ [140]	8 <sup>3</sup> / <sub>16</sub> [208]	9 <sup>9</sup> / <sub>16</sub> [243]	7 [179]	4 <sup>11</sup> / <sub>16</sub> [119]
12*	5 [127]	7 [178]	9 <sup>5</sup> / <sub>8</sub> [245]	11 <sup>5</sup> / <sub>8</sub> [295]	8 [203]	5 <sup>3</sup> / <sub>8</sub> [137]
15*	5 [127]	7 [178]	10½ [267]	12½ [318]	9½ [241]	6¼ [159]

<sup>A</sup> For details of hubs and spigots, see Table 1.

<sup>B\*</sup> indicates this item is made in extra heavy.

O indicates this item is made in service weight.

**ASTM A 74**

**TABLE 11 Dimensions of One-Eighth, Long One-Eighth Bends, and One-Sixteenth Bends**

NOTE 1—1 in. = 25.4 mm.

NOTE 2—Dimensions *D* and *X* are laying lengths.

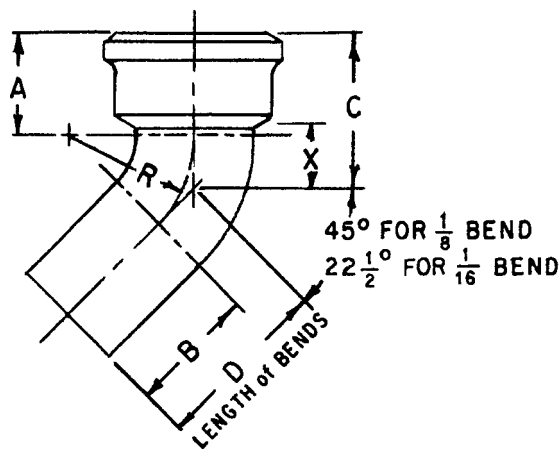

Size, In., Availability <sup>A</sup>	Dimensions in in. <sup>B</sup>					
	A	B	C	D	R	X
<b>One-Eighth Bends</b>						
2°O	2 $\frac{3}{4}$ [70]	3 [76]	4 [102]	4 $\frac{1}{4}$ [108]	3 [76]	1 $\frac{1}{2}$ [38]
3°O	3 $\frac{1}{4}$ [83]	3 $\frac{1}{2}$ [89]	4 $\frac{1}{4}$ [103]	4 $\frac{15}{16}$ [125]	3 $\frac{1}{2}$ [89]	1 $\frac{5}{16}$ [49]
4°O	3 $\frac{1}{2}$ [89]	4 [102]	5 $\frac{3}{16}$ [132]	5 $\frac{1}{16}$ [145]	4 [102]	2 $\frac{3}{16}$ [56]
5°O	3 $\frac{1}{2}$ [89]	4 [102]	5 $\frac{3}{8}$ [137]	5 $\frac{7}{8}$ [149]	4 $\frac{1}{2}$ [114]	2 $\frac{3}{8}$ [60]
6°O	3 $\frac{1}{2}$ [89]	4 [102]	5 $\frac{9}{16}$ [142]	6 $\frac{1}{16}$ [154]	5 [127]	2 $\frac{9}{16}$ [65]
8°O	4 $\frac{1}{8}$ [105]	5 $\frac{1}{2}$ [140]	6 $\frac{3}{8}$ [168]	8 [203]	6 [152]	3 $\frac{1}{8}$ [79]
10°O	4 $\frac{1}{2}$ [114]	5 $\frac{1}{2}$ [140]	7 [178]	8 $\frac{3}{8}$ [213]	7 [178]	3 $\frac{1}{2}$ [89]
12°O	5 [127]	7 [178]	8 $\frac{5}{16}$ [211]	10 $\frac{3}{16}$ [262]	8 [203]	4 $\frac{1}{16}$ [103]
15°O	5 [127]	7 [178]	8 $\frac{15}{16}$ [227]	10 $\frac{15}{16}$ [278]	9 $\frac{1}{2}$ [241]	4 $\frac{11}{16}$ [119]
<b>Long One-Eighth Bends</b>						
2 by 12°O	2 $\frac{3}{4}$ [70]	10 $\frac{3}{4}$ [273]	4 [102]	12 [305]	3 [76]	1 $\frac{1}{2}$ [38]
2 by 18°O	2 $\frac{3}{4}$ [70]	16 $\frac{3}{4}$ [425]	4 [102]	18 [457]	3 [76]	1 $\frac{1}{2}$ [38]
2 by 24°O	2 $\frac{3}{4}$ [70]	22 $\frac{3}{4}$ [578]	4 [102]	24 [610]	3 [76]	1 $\frac{1}{2}$ [38]
3 by 12°O	3 $\frac{1}{4}$ [83]	10 $\frac{9}{16}$ [269]	4 $\frac{1}{16}$ [119]	12 [305]	3 $\frac{1}{2}$ [89]	1 $\frac{5}{16}$ [49]
3 by 18°O	3 $\frac{1}{4}$ [83]	16 $\frac{9}{16}$ [421]	4 $\frac{1}{16}$ [119]	18 [457]	3 $\frac{1}{2}$ [89]	1 $\frac{5}{16}$ [49]
3 by 24°O	3 $\frac{1}{4}$ [83]	22 $\frac{9}{16}$ [573]	4 $\frac{1}{16}$ [119]	24 [610]	3 $\frac{1}{2}$ [89]	1 $\frac{5}{16}$ [49]
4 by 12°O	3 $\frac{1}{2}$ [89]	10 $\frac{5}{16}$ [261]	5 $\frac{3}{16}$ [12]	12 [305]	4 [102]	2 $\frac{3}{16}$ [56]
4 by 18°O	3 $\frac{1}{2}$ [89]	16 $\frac{5}{16}$ [414]	5 $\frac{3}{16}$ [132]	18 [457]	4 [102]	2 $\frac{3}{16}$ [56]
4 by 24°O	3 $\frac{1}{2}$ [89]	22 $\frac{5}{16}$ [567]	5 $\frac{3}{16}$ [132]	24 [610]	4 [102]	2 $\frac{3}{16}$ [56]
<b>One-Sixteenth Bends</b>						
2°O	2 $\frac{3}{4}$ [70]	3 [76]	3 $\frac{3}{8}$ [86]	3 $\frac{5}{8}$ [92]	3 [76]	$\frac{7}{8}$ [22]
3°O	3 $\frac{1}{4}$ [83]	3 $\frac{1}{2}$ [89]	3 $\frac{15}{16}$ [100]	4 $\frac{3}{16}$ [107]	3 $\frac{1}{2}$ [89]	1 $\frac{3}{16}$ [30]
4°O	3 $\frac{1}{2}$ [90]	4 [102]	4 $\frac{5}{16}$ [109]	4 $\frac{3}{4}$ [122]	4 [102]	1 $\frac{5}{16}$ [33]
5°O	3 $\frac{1}{2}$ [90]	4 [102]	4 $\frac{3}{8}$ [111]	4 $\frac{7}{8}$ [124]	4 $\frac{1}{2}$ [114]	1 $\frac{3}{8}$ [35]
6°O	3 $\frac{1}{2}$ [90]	4 [102]	4 $\frac{1}{2}$ [114]	5 [127]	5 [127]	1 $\frac{1}{2}$ [38]
8°O	4 $\frac{1}{8}$ [105]	5 $\frac{1}{2}$ [140]	5 $\frac{5}{16}$ [135]	6 $\frac{1}{16}$ [170]	6 [152]	1 $\frac{3}{16}$ [46]
10°O	4 $\frac{1}{8}$ [105]	5 $\frac{1}{2}$ [140]	5 $\frac{1}{2}$ [140]	6 $\frac{3}{8}$ [175]	7 [178]	2 [51]
12°O	5 [127]	7 [178]	6 $\frac{3}{8}$ [168]	8 $\frac{3}{8}$ [219]	8 [203]	2 $\frac{3}{8}$ [60]
15°O	5 [127]	7 [178]	6 $\frac{7}{8}$ [175]	8 $\frac{7}{8}$ [225]	9 $\frac{1}{2}$ [241]	2 $\frac{5}{8}$ [67]

<sup>A</sup> For details of hubs and spigots, see Table 1.

<sup>B</sup> \* indicates this item is made in extra heavy.

O indicates this item is made in service weight.

**ASTM A 74**

**TABLE 12 Dimensions of Y Branches, Single**

NOTE 1—1 in. = 25.4 mm.

NOTE 2—Dimensions *D* and *X* are laying lengths.

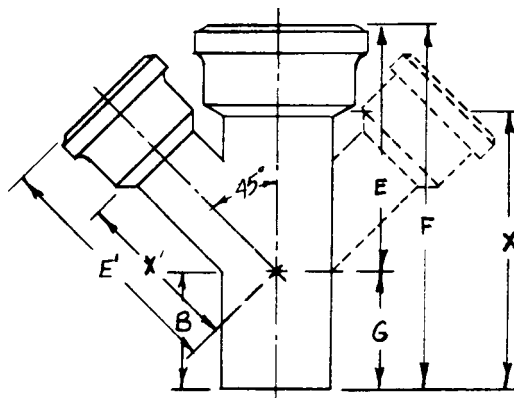

Size, in., Availability <sup>A</sup>	Single Dimensions in in. <sup>B</sup>						
	<i>B</i> (min)	<i>E</i>	<i>E'</i>	<i>F</i>	<i>G</i>	<i>X</i>	<i>X'</i>
2"O	3½ [88]	6½ [165]	6½ [165]	10½ [267]	4 [102]	8 [203]	4 [102]
3"O	4 [102]	8¼ [210]	8¼ [210]	13¼ [337]	5 [127]	10½ [267]	5½ [140]
4"O	4 [102]	9¾ [248]	9¾ [248]	15 [381]	5¼ [133]	12 [305] [305]	6¾ [171]
5"O	4 [102]	11 [279]	11 [279]	16½ [409]	5½ [140]	13½ [343]	8 [203]
6"O	4 [102]	12¼ [311]	12¼ [311]	18 [457]	5¾ [16]	15 [381]	9¼ [235]
8"O	5½ [140]	15¾ [389]	15¾ [389]	23 [584]	7¼ [195]	19½ [495]	11¼ [300]
10"O	5½ [10]	18 [457]	18 [457]	26 [660]	8 [203]	22½ [572]	14½ [368]
12"O	7 [178]	21½ [537]	21½ [537]	31¼ [794]	10⅞ [257]	27 [686]	16⅞ [429]
15"O	7 [178]	25 [635]	25 [635]	35¾ [908]	10¾ [273]	31½ [800]	20¾ [527]
3 by 2"O	4 [102]	7⅞ [192]	7¼ [191]	11¾ [298]	4¾ [106]	9 [229]	5 [127]
4 by 2"O	4 [102]	8⅞ [213]	8¼ [210]	12 [305]	3⅞ [92]	9 [229]	5¾ [146]
4 by 3"O	4 [102]	9⅞ [230]	9 [229]	13½ [343]	4⅞ [113]	10½ [267]	6¼ [159]
5 by 2"O	4 [102]	8⅞ [255]	9 [229]	12 [305]	3⅞ [79]	9 [229]	6½ [165]
5 by 3"O	4 [102]	9⅞ [244]	9¾ [248]	13½ [343]	3⅞ [98]	10½ [267]	7 [178]
5 by 4"O	4 [102]	10⅞ [262]	10½ [267]	15 [381]	4⅞ [119]	12 [305]	7½ [191]
6 by 2"O	4 [102]	9⅞ [240]	9¾ [248]	12 [305]	2⅞ [65]	9 [229]	7¼ [184]
6 by 3"O	4 [102]	10⅞ [257]	10½ [267]	13½ [343]	3⅞ [86]	10½ [267]	7¾ [197]
6 by 4"O	4 [102]	10⅞ [275]	11¼ [286]	15 [381]	4⅞ [106]	12 [305]	8¼ [210]
6 by 5"O	4 [102]	11⅞ [294]	11¾ [298]	16½ [419]	4⅞ [125]	13½ [343]	8¾ [222]
8 by 2"O	5½ [140]	10⅞ [276]	11 [279]	14 [356]	3⅞ [79]	10½ [267]	8½ [216]
8 by 3"O	5½ [140]	11⅞ [294]	11¾ [298]	15½ [394]	3⅞ [100]	12 [305]	9 [229]
8 by 4"O	5½ [140]	12¼ [311]	12½ [318]	17 [432]	4¾ [121]	13½ [343]	9½ [241]
8 by 5"O	5½ [140]	13 [330]	13 [330]	18½ [470]	5½ [140]	15 [381]	10 [254]
8 by 6"O	5½ [140]	13⅞ [348]	13½ [343]	20 [508]	6⅞ [160]	16½ [419]	10½ [267]
10 by 4"O	5½ [140]	13⅞ [341]	14⅞ [359]	17 [432]	3⅞ [90]	13½ [343]	11⅞ [283]
10 by 5"O	5½ [140]	14⅞ [360]	14⅞ [371]	18½ [470]	4⅞ [110]	15 [381]	11⅞ [296]
10 by 6"O	5½ [140]	14⅞ [378]	15⅞ [384]	20 [508]	5⅞ [130]	16½ [419]	12⅞ [308]
10 by 8"O	5½ [140]	16½ [419]	16⅞ [430]	23 [584]	6½ [165]	19½ [495]	13⅞ [341]
12 by 4"O	7 [178]	15⅞ [384]	15⅞ [392]	19¼ [489]	4⅞ [105]	15 [381]	12⅞ [316]
12 by 5"O	7 [178]	15⅞ [430]	15⅞ [405]	20¾ [527]	4⅞ [124]	16½ [419]	12⅞ [329]
12 by 6"O	7 [178]	16⅞ [421]	16⅞ [418]	22¼ [565]	5⅞ [144]	18 [457]	13⅞ [341]
12 by 8"O	7 [178]	18⅞ [462]	18¼ [464]	25¼ [641]	7⅞ [179]	21 [533]	14¾ [375]
12 by 10"O	7 [178]	19⅞ [500]	19⅞ [491]	28¼ [718]	8⅞ [217]	24 [610]	15⅞ [402]
15 by 6"O	7 [178]	18¼ [464]	18¼ [476]	22¼ [565]	4 [102]	18 [457]	15¾ [400]
15 by 8"O	7 [178]	19⅞ [505]	20⅞ [522]	25¼ [641]	5⅞ [137]	21 [533]	17⅞ [433]
15 by 10"O	7 [178]	21⅞ [543]	21⅞ [549]	28¼ [718]	6⅞ [175]	24 [610]	18⅞ [460]
15 by 12"O	7 [178]	22⅞ [579]	23⅞ [595]	31¼ [794]	8⅞ [214]	27 [686]	19¾ [487]

<sup>A</sup> \* indicates this item is made in extra heavy.

O indicates this item is made in service weight.

<sup>B</sup> For details of hubs and spigots, see Table 1. For details of side inlets see Fig. 3.





**TABLE 13 Dimensions of Y Branches, Double**

NOTE 1—1 in. = 25.4 mm.

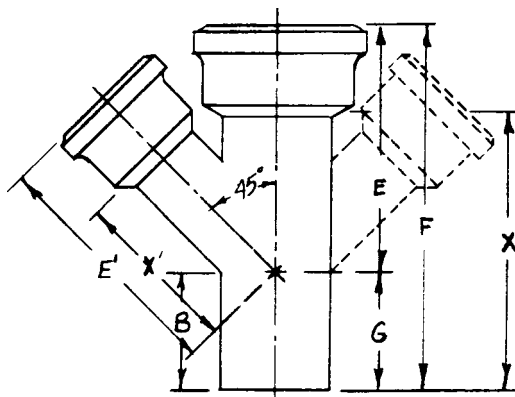

Size, in., Availability <sup>A</sup>	Double Dimensions in in. <sup>B</sup>						
	B (min)	E	E'	F	G	X	X'
2°O	3½ [89]	6½ [165]	6½ [165]	10½ [267]	4 [102]	8 [203]	4 [102]
3°O	4 [102]	8¼ [210]	8¼ [210]	13¼ [337]	5 [127]	10½ [267]	5½ [140]
4°O	4 [102]	9¾ [248]	9¾ [248]	15 [381]	5¼ [133]	12 [305]	9¼ [235]
5°O	4 [102]	11 [279]	11 [279]	16½ [419]	5½ [140]	13½ [343]	8 [203]
6°O	4 [102]	12¼ [311]	12¼ [311]	18 [457]	5¾ [146]	15 [381]	9¼ [235]
8°O	5½ [140]	15⅝ [389]	15⅝ [389]	23 [584]	7⅞ [195]	19½ [495]	11⅜ [300]
10°O	5½ [140]	18 [457]	18 [457]	26 [660]	8 [203]	22½ [572]	14½ [368]
12°O	7 [178]	21⅞ [537]	21⅞ [537]	31¼ [794]	10⅞ [257]	27 [686]	16⅞ [429]
15°O	7 [178]	25 [635]	25 [635]	35¾ [908]	10¾ [273]	31½ [800]	20¾ [527]
3 by 2°O	4 [102]	7⅞ [192]	7½ [191]	11¾ [298]	4⅞ [106]	9 [229]	5 [127]
4 by 2°O	4 [102]	8⅞ [213]	8¼ [210]	12 [305]	3⅞ [86]	9 [229]	5¾ [146]
4 by 3°O	4 [102]	9⅞ [230]	9 [229]	13½ [343]	4⅞ [113]	10½ [267]	6¼ [159]
5 by 2°O	4 [102]	8⅞ [255]	9 [229]	12 [305]	3⅞ [79]	9 [229]	6½ [165]
5 by 3°O	4 [102]	9⅞ [244]	9¾ [248]	13½ [343]	3⅞ [98]	10½ [267]	7 [178]
5 by 4°O	4 [102]	10⅞ [262]	10½ [267]	15 [381]	4⅞ [119]	12 [305]	7½ [191]
6 by 2°O	4 [102]	9⅞ [240]	9¾ [248]	12 [305]	2⅞ [65]	9 [229]	7¼ [184]
6 by 3°O	4 [102]	10⅞ [257]	10½ [267]	13½ [343]	3⅞ [86]	10½ [267]	7 [178]
6 by 4°O	4 [102]	10⅞ [275]	11¼ [286]	15 [381]	4⅞ [106]	12 [305]	8¼ [210]
6 by 5°O	4 [102]	11⅞ [294]	11¾ [298]	16½ [419]	4⅞ [125]	13½ [343]	8¾ [222]
8 by 4°O	5½ [140]	12¼ [311]	12½ [318]	17 [432]	4¾ [121]	13½ [343]	9½ [241]
8 by 5°O	5½ [140]	13 [330]	13 [330]	18½ [470]	5½ [140]	15 [381]	10 [254]
8 by 6°O	5½ [140]	13⅞ [348]	13½ [343]	20 [208]	6⅞ [160]	16½ [419]	10½ [267]
10 by 4°O	5½ [140]	13⅞ [341]	14⅞ [359]	17 [432]	3⅞ [90]	13½ [343]	11⅞ [283]
10 by 6°O	5½ [140]	14⅞ [378]	15⅞ [384]	20 [508]	5⅞ [130]	16½ [419]	12⅞ [308]
10 by 8°O	5½ [140]	16½ [419]	16⅞ [430]	23 [584]	6½ [165]	19½ [495]	13⅞ [341]
12 by 6°O	7 [178]	16⅞ [421]	16⅞ [418]	22¼ [565]	5⅞ [144]	18 [457]	13⅞ [341]
12 by 8°O	7 [178]	18⅞ [462]	18¼ [464]	25¼ [641]	7⅞ [179]	21 [533]	14¾ [375]

<sup>A</sup> \* indicates this item is made in extra heavy.

O indicates this item is made in service weight.

<sup>B</sup> For details of hubs and spigots, see Table 1. For details of side inlets see Fig. 3.

**ASTM A 74**

**TABLE 14 Dimensions of Y-Branch Cleanout with Screw Plug on Main**

NOTE 1—1 in. = 25.4 mm.

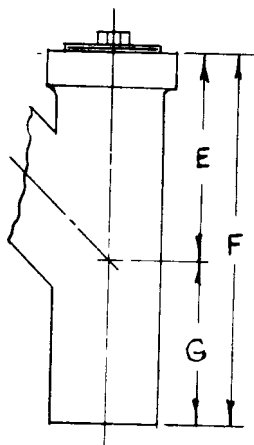

Size, in., Availability	Dimensions in in. <sup>A</sup>					Minimum I.P.S. <sup>A</sup> tapping
	E	E'	F	G	X'	
2"O	5¼ [133]	6½ [165]	9¼ [235]	4 [102]	4 [102]	1½ [38]
3"O	6⅝ [168]	8¼ [210]	11⅝ [295]	5 [127]	5½ [140]	2½ [64]
4"O	7⅞ [200]	9¾ [248]	13⅞ [333]	5¼ [133]	6¾ [171]	3½ [89]

<sup>A</sup> See notes under Table 15 to 5-inch sizes.

**TABLE 15 Dimensions of Y Branch Cleanout with Screw Plug on Branch**

NOTE 1—1 in. = 25.4 mm.

NOTE 2—Dimensions X and X' are laying lengths.

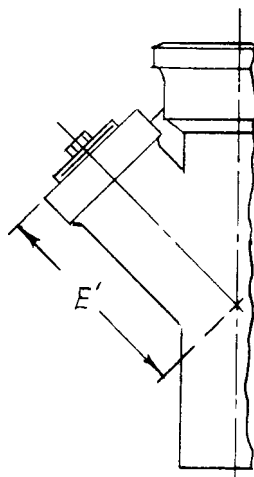

Size, in., Availability <sup>A</sup>	Dimensions in in. <sup>B</sup>					Minimum I.P.S. <sup>C,D</sup> tapping
	E	E'	F	G	X	
2"O	6⅞ [156]	5¼ [133]	10½ [267]	4 [102]	8 [203]	1½ [38]
3"O	8¼ [210]	6⅝ [168]	13¼ [337]	5 [127]	10½ [267]	2½ [64]
4"O	9¾ [248]	7⅞ [200]	15 [381]	5¼ [133]	12 [305]	3½ [89]

<sup>A</sup> \* indicates this item is made in extra heavy.

O indicates this item is made in service weight.

<sup>B</sup> For details of hubs and spigots, see Table 1. For details of tapping bosses, see Table 42 and for details of screw plugs, see Table 38.

<sup>C</sup> Iron pipe sizes.

<sup>D</sup> Tappings permit entrance of testing plugs.

**ASTM A 74**

**TABLE 16 Dimensions of Y Branches, Inverted, Single**

NOTE 1—1 in. = 25.4 mm.

NOTE 2—Dimensions  $X$  and  $X'$  are laying lengths.

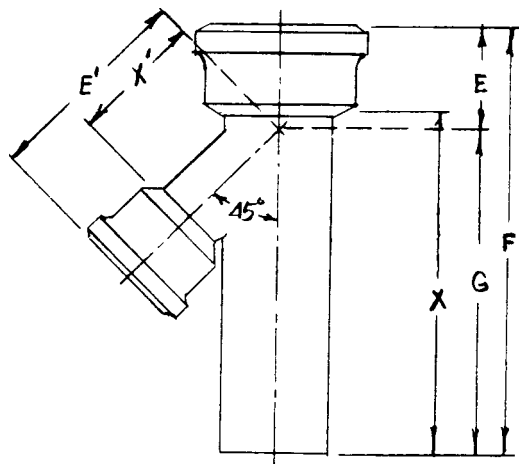

Size, in. Availability <sup>A</sup>	Dimensions in in. <sup>B</sup>					
	$E$	$E'$	$F$	$G$	$X$	$X'$
2"O	3/4 [82]	5/8 [149]	12 [305]	8 3/4 [222]	9 1/2 [241]	3 3/8 [86]
3"O	4 [102]	7 3/8 [187]	15 1/4 [387]	11 1/4 [286]	12 1/2 [318]	4 5/8 [117]
4"O	4 1/2 [114]	8 7/8 [225]	17 [432]	12 1/2 [318]	14 [356]	5 7/8 [149]
3 by 2"O	3/4 [82]	6 5/8 [168]	13 3/4 [349]	10 1/2 [267]	11 [279]	4 1/8 [105]
4 by 2"O	3 1/16 [78]	7 3/8 [187]	14 [356]	10 1 5/16 [278]	11 [279]	4 7/8 [124]
4 by 3"O	3/4 [95]	8 1/8 [206]	15 1/2 [394]	11 3/4 [298]	12 1/2 [318]	5 3/8 [137]

<sup>A</sup> \* indicates this item is made in extra heavy.

O indicates this item is made in service weight.

<sup>B</sup> For details of hubs and spigots, see Table 1.



**TABLE 17 Dimensions of Combination Y and One-Eighth Bend, Single and Double**

NOTE 1—1 in. = 25.4 mm.

NOTE 2—Dimensions X and X' are laying lengths.

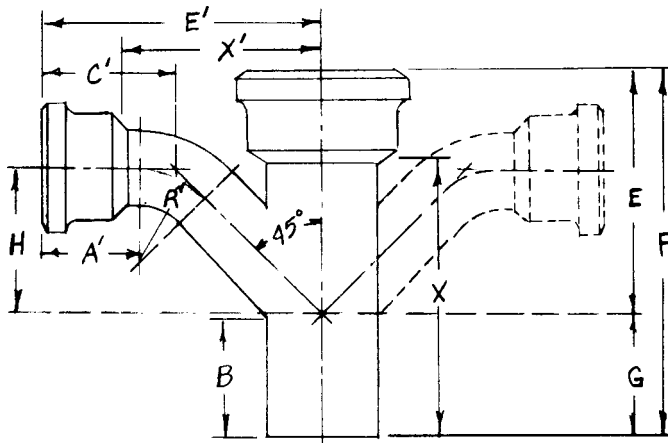

Size, in., Availability <sup>A</sup>	Dimensions in in. <sup>B</sup>											
	A'	B (min)	C'	E	E'	F	G	H	R'	X	X'	
Single:												
2"O	2¾ [70]	3½ [89]	4 [102]	6½ [165]	7¾ [187]	10½ [267]	4 [102]	3¾ [86]	3 [76]	8 [203]	4⅞ [124]	
3"O	3¼ [83]	4 [102]	4⅞ [119]	8¼ [210]	9¾ [248]	13¼ [337]	5 [127]	5⅞ [129]	3½ [89]	10½ [267]	7 [178]	
4"O	3½ [89]	4 [102]	5⅞ [132]	9¾ [248]	12 [305]	15 [381]	5¼ [133]	6⅞ [173]	4 [102]	12 [305]	9 [229]	
5"O	3½ [89]	4 [102]	5⅞ [137]	11 [279]	14 [356]	16½ [419]	5½ [140]	8⅞ [219]	4½ [114]	13½ [343]	11 [279]	
6"O	3½ [89]	4 [102]	5⅞ [141]	12¼ [311]	15⅞ [403]	18 [457]	5¾ [146]	10⅞ [262]	5 [127]	15 [381]	12⅞ [327]	
8"O	4⅞ [105]	5½ [140]	6⅞ [168]	15⅞ [389]	20½ [521]	23 [584]	7⅞ [195]	13⅞ [352]	6 [152]	19½ [495]	17 [432]	
3 by 2"O	3 [76]	4 [102]	4¼ [108]	7⅞ [192]	8¼ [209]	11¾ [299]	4⅞ [106]	4 [102]	3 [76]	9 [229]	5¾ [146]	
4 by 2"O	3 [76]	4 [102]	4¼ [108]	8⅞ [211]	8¾ [222]	12 [305]	3⅞ [94]	4½ [114]	3 [76]	9 [229]	6¼ [159]	
4 by 3"O	3¼ [83]	4 [102]	4⅞ [119]	9 [229]	10¼ [260]	13½ [343]	4½ [114]	5⅞ [141]	3½ [89]	10½ [267]	7½ [191]	
5 by 2"O	3 [76]	4 [102]	4¼ [108]	8⅞ [219]	9¼ [235]	12 [305]	3⅞ [86]	5 [127]	3 [76]	9 [229]	6¾ [171]	
5 by 3"O	3¼ [83]	4 [102]	4⅞ [119]	9½ [241]	10¾ [273]	13½ [343]	4 [102]	6⅞ [154]	3½ [89]	10½ [267]	8 [203]	
5 by 4"O	3½ [89]	4 [102]	5⅞ [132]	10¼ [260]	12½ [318]	15 [381]	4¼ [108]	7⅞ [185]	4 [102]	12 [305]	9½ [241]	
6 by 2"O	3 [76]	4 [102]	4¼ [108]	9⅞ [237]	9¾ [248]	12 [305]	2⅞ [68]	5½ [140]	3 [76]	9 [229]	7¼ [184]	
6 by 3"O	3¼ [83]	4 [102]	4⅞ [119]	10 [257]	11¼ [286]	13½ [343]	3⅞ [79]	6⅞ [167]	3½ [89]	10¼ [260]	8½ [216]	
6 by 4"O	3½ [89]	4 [102]	5⅞ [132]	10¾ [237]	13 [330]	15 [381]	4¼ [108]	7⅞ [198]	4 [102]	12 [305]	10 [254]	
6 by 5"O	3½ [89]	4 [102]	5⅞ [137]	11⅞ [291]	14½ [368]	16½ [419]	5⅞ [129]	9⅞ [232]	4½ [114]	13½ [343]	11½ [292]	
8 by 2"O	3 [76]	5½ [140]	4¼ [108]	10⅞ [276]	10¾ [273]	14 [356]	3⅞ [79]	6⅞ [165]	3 [76]	10½ [267]	8¼ [210]	
8 by 4"O	3½ [89]	5½ [140]	5⅞ [132]	12¼ [311]	14 [356]	17 [432]	4¾ [121]	8⅞ [224]	4 [102]	13½ [343]	11 [279]	
8 by 5"O	3½ [89]	5½ [140]	5⅞ [137]	13 [330]	15½ [394]	18½ [470]	5½ [140]	10⅞ [257]	4½ [114]	15 [381]	12½ [318]	
8 by 6"O	3½ [89]	5½ [140]	5⅞ [141]	13⅞ [348]	16⅞ [429]	20 [508]	6⅞ [160]	11⅞ [287]	5 [127]	16½ [419]	13⅞ [352]	
Double:												
2"O	2¼ [57]	3½ [89]	4 [102]	6½ [165]	7¾ [187]	10½ [267]	4 [102]	3¾ [86]	3 [76]	8 [203]	4⅞ [124]	
3"O	3¼ [83]	4 [102]	4⅞ [119]	8¼ [210]	9¾ [248]	13¼ [337]	5 [127]	5⅞ [129]	3½ [89]	10½ [267]	7 [178]	
4"O	3½ [89]	4 [102]	5⅞ [132]	9¾ [248]	12 [305]	15 [381]	5¼ [133]	6⅞ [173]	4 [102]	12 [305]	9 [229]	
5"O	3½ [89]	4 [102]	5⅞ [137]	11 [279]	14 [356]	16½ [419]	5½ [140]	8⅞ [219]	4½ [114]	13½ [343]	11 [279]	
6"O	3½ [89]	4 [102]	5⅞ [141]	12¼ [311]	15⅞ [403]	18 [457]	5¾ [146]	10⅞ [262]	5 [127]	15 [381]	12⅞ [327]	
3 by 2"O	3 [76]	4 [102]	4¼ [108]	7⅞ [192]	8¼ [210]	11¾ [298]	4⅞ [106]	4 [102]	3 [76]	9 [229]	5¾ [146]	
4 by 2"O	3 [76]	4 [102]	4¼ [108]	8⅞ [211]	8¾ [222]	12 [305]	3⅞ [94]	4½ [114]	3 [76]	9 [229]	6¼ [146]	
4 by 3"O	3¼ [83]	4 [102]	4⅞ [119]	9 [229]	10¼ [260]	13½ [343]	4½ [114]	5⅞ [141]	3½ [89]	10½ [267]	7½ [191]	
5 by 4"O	3½ [89]	4 [102]	5⅞ [132]	10¼ [260]	12½ [318]	15 [381]	4¾ [121]	7⅞ [186]	4 [102]	12 [305]	9½ [241]	
6 by 4"O	3½ [89]	4 [102]	5⅞ [132]	10¾ [273]	13 [330]	15 [381]	4¼ [108]	7⅞ [198]	4 [102]	12 [305]	10 [254]	

<sup>A</sup> \* indicates this item is made in extra heavy.

O indicates this item is made in service weight.

<sup>B</sup> For details of hubs and spigots, see Table 1; for details of side inlets, see Fig. 3.

**ASTM A 74**

**TABLE 18 Dimensions of Combination Y and One-Eighth Bend Cleanout with Screw Plug on Main**

NOTE 1—1 in. = 25.4 mm.

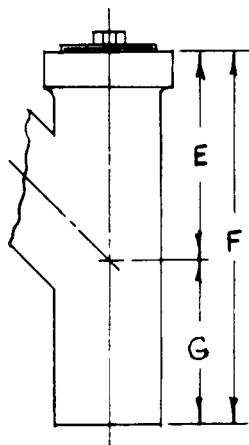

Size, in., Availability <sup>A</sup>	Dimensions in in. <sup>B</sup>		Min. I.P.S. tapping <sup>C</sup>	Size (in.)	Dimensions in in. <sup>B</sup>		Min. I.P.S. tapping <sup>A</sup>
	E	F			E	F	
2"O	5¼ [133]	9¼ [235]	1½ [38]	5 [127]	9⅞ [232]	14⅝ [371]	4 [102]
3"O	6⅝ [168]	11⅞ [295]	2½ [64]	6 [152]	10⅞ [264]	16⅞ [410]	5 [127]
4"O	7⅞ [181]	13⅞ [333]	3½ [89]				

<sup>A</sup>\* indicates this item is made in extra heavy.

O indicates this item is made in service weight.

<sup>B</sup> For dimensions not given in this table see Table 17. For details of hubs and spigots, see Table 1.

<sup>C</sup> For details of tapping bosses, see Table 42 and for details of screw plugs, see Table 38.

**TABLE 19 Dimensions of Y Branches, Upright, Single**

NOTE 1—1 in. = 25.4 mm.

NOTE 2—Dimensions X and X' are laying lengths.

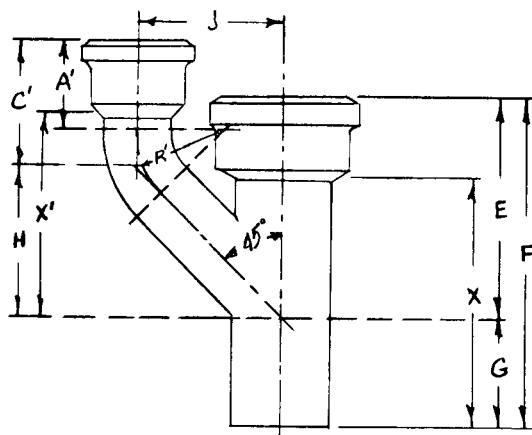

Size, in. Availability <sup>A</sup>	Dimensions in in. <sup>B</sup>									
	A'	C'	E	F	G	H	J	R'	X	X'
2"O	2¾ [70]	4 [102]	6½ [165]	10½ [267]	4 [102]	4½ [114]	4½ [114]	3 [76]	8 [203]	6 [152]
3"O	3¼ [83]	4⅞ [119]	8¼ [210]	13¼ [337]	5 [127]	5½ [140]	5½ [140]	3½ [89]	10½ [267]	7⅞ [189]
4"O	3½ [89]	5⅞ [132]	9¾ [248]	15 [381]	5¼ [133]	6½ [165]	6½ [165]	4 [102]	12 [305]	8⅞ [221]
3 by 2"O	3 [76]	4¼ [108]	7⅞ [192]	11¾ [298]	4⅞ [106]	5 [127]	5 [127]	3 [76]	9 [229]	6¾ [171]
4 by 2"O	3 [76]	4¼ [108]	8⅞ [211]	12 [305]	3⅞ [94]	5½ [140]	5½ [140]	3 [76]	9 [229]	7¼ [184]
4 by 3"O	3¼ [83]	4⅞ [119]	9 [229]	13½ [343]	4½ [114]	5 [127]	6 [152]	3½ [89]	10½ [267]	6⅞ [176]

<sup>A</sup>\* indicates this item is made in extra heavy.

O indicates this item is made in service weight.

<sup>B</sup> For details of hubs and spigots, see Table 1.



**TABLE 20 Dimensions of Sanitary T Branches, Single and Double**

NOTE 1—1 in. = 25.4 mm.

NOTE 2—Dimensions X and X' are laying lengths.

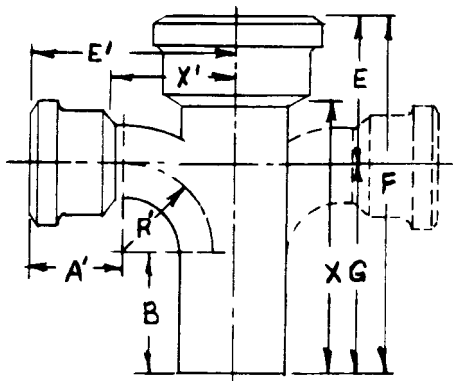

Size, in., Availability <sup>A</sup>	Dimensions in in. <sup>B</sup>								
	A'	B	E	E'	F	G	R'	X	X'
Single:									
2"O	2¾ [70]	3¾ [95]	4¼ [108]	5¼ [133]	10½ [267]	6¼ [159]	2½ [64]	8 [203]	2¾ [70]
3"O	3¼ [83]	4 [102]	5¼ [133]	6¾ [171]	12¾ [324]	7½ [191]	3½ [89]	10 [254]	4 [102]
4"O	3½ [89]	4 [102]	6 [152]	7½ [190]	14 [356]	8 [203]	4 [102]	11 [279]	4½ [114]
5"O	3½ [89]	4 [102]	6½ [165]	8 [203]	15 [381]	8½ [216]	4½ [114]	12 [305]	5 [127]
6"O	3½ [89]	4 [102]	7 [178]	8½ [216]	16 [406]	9 [229]	5 [127]	13 [330]	5½ [140]
8"O	4½ [105]	5¾ [146]	8¾ [222]	10½ [257]	20½ [521]	11¾ [298]	6 [152]	17 [432]	6½ [168]
10"O	4½ [105]	5¾ [146]	9¾ [248]	11½ [283]	22½ [572]	12¾ [324]	7 [178]	19 [483]	7½ [194]
12"O	5 [127]	7 [178]	11¾ [298]	13 [330]	26¼ [679]	15 [381]	8 [203]	22½ [572]	8¾ [222]
15"O	5 [127]	7 [178]	13¼ [337]	14½ [368]	29¾ [755]	16½ [419]	9½ [241]	25½ [648]	10¼ [260]
3 by 2"O	3 [76]	4 [102]	4¾ [121]	6½ [165]	11¾ [298]	7 [178]	3 [76]	9 [229]	4 [102]
4 by 2"O	3 [76]	4 [102]	5 [127]	7 [178]	12 [305]	7 [178]	3 [76]	9 [229]	4½ [114]
4 by 3"O	3¼ [83]	4 [102]	5½ [140]	7¼ [184]	13 [330]	7½ [191]	3½ [89]	10 [254]	4½ [114]
5 by 2"O	3 [76]	4 [102]	5 [127]	7½ [191]	12 [305]	7 [178]	3 [76]	9 [229]	5 [127]
5 by 3"O	3¼ [83]	4 [102]	5½ [140]	7¾ [197]	13 [330]	7½ [191]	3½ [89]	10 [254]	5 [127]
5 by 4"O	3½ [89]	4 [102]	6 [152]	8 [203]	14 [356]	8 [203]	4 [102]	11 [279]	5 [127]
6 by 2"O	3 [76]	4 [102]	5 [127]	8 [203]	12 [305]	7 [178]	3 [76]	9 [229]	5½ [140]
6 by 3"O	3¼ [83]	4 [102]	5½ [140]	8¼ [210]	13 [330]	7½ [191]	3½ [89]	10 [254]	5½ [140]
6 by 4"O	3½ [89]	4 [102]	6 [152]	8½ [216]	14 [356]	8 [203]	4 [102]	11 [279]	5½ [140]
6 by 5"O	3½ [89]	4 [102]	6½ [165]	8½ [216]	15 [381]	8½ [216]	4½ [114]	12 [305]	5½ [140]
8 by 4"O	3½ [89]	5¾ [146]	6¾ [171]	9½ [241]	16½ [419]	9¾ [248]	4 [102]	13 [330]	6½ [165]
8 by 5"O	3½ [89]	5¾ [146]	7¼ [184]	9½ [241]	17½ [445]	10¼ [260]	4½ [114]	14 [356]	6½ [165]
8 by 6"O	3½ [89]	5¾ [146]	7¾ [197]	9½ [241]	18½ [470]	10¾ [273]	5 [127]	15 [381]	6½ [165]
10 by 4"O	3½ [89]	5¾ [146]	6¾ [171]	10½ [267]	16½ [419]	9¾ [240]	4 [102]	13 [330]	7½ [191]
10 by 6"O	3½ [89]	5¾ [146]	7¾ [197]	10½ [267]	18½ [470]	10¾ [273]	5 [127]	15 [381]	7½ [191]
10 by 8"O	4½ [105]	5¾ [146]	8¾ [222]	11½ [283]	20½ [521]	11¾ [298]	6 [152]	17 [432]	7½ [191]
12 by 6"O	3½ [89]	7 [178]	8¾ [222]	11½ [292]	20¾ [527]	12 [305]	5 [127]	16½ [419]	8½ [216]
12 by 8"O	4½ [105]	7 [178]	9¾ [248]	12½ [308]	22¾ [578]	13 [330]	6 [152]	18½ [470]	8½ [216]
12 by 10"O	4½ [105]	7 [178]	10¾ [273]	12½ [308]	24¾ [629]	14 [356]	7 [178]	20½ [521]	8½ [216]
15 by 6"O	3½ [89]	7 [178]	8¾ [222]	13 [330]	20¾ [527]	12 [305]	5 [127]	16½ [419]	10 [254]
15 by 8"O	4½ [105]	7 [178]	9¾ [248]	13¾ [346]	22¾ [578]	13 [330]	6 [152]	18½ [470]	10½ [257]
15 by 10"O	4½ [105]	7 [178]	10¾ [273]	13¾ [346]	24¾ [629]	14 [356]	7 [178]	20½ [521]	10½ [257]
15 by 12"O	5 [127]	7 [178]	11¾ [298]	14½ [368]	26¾ [679]	15 [381]	8 [203]	22½ [572]	10¾ [260]
Double:									
2"O	2¾ [70]	3¾ [95]	4¼ [108]	5¼ [133]	10½ [267]	6¼ [159]	2½ [64]	8 [203]	2¾ [70]
3"O	3¼ [83]	4 [102]	5¼ [133]	6¾ [171]	12¾ [324]	7½ [191]	3½ [89]	10 [254]	4 [102]
4"O	3½ [89]	4 [102]	6 [152]	7½ [191]	14 [356]	8 [203]	4 [102]	11 [279]	4½ [114]
5"O	3½ [89]	4 [102]	6½ [165]	8 [203]	15 [381]	8½ [216]	4½ [114]	12 [305]	5 [127]
6"O	3½ [89]	4 [102]	7 [178]	8½ [216]	16 [406]	9 [229]	5 [127]	13 [330]	5½ [140]
8"O	4½ [105]	5¾ [146]	8¾ [222]	10½ [257]	20½ [521]	11¾ [298]	6 [152]	17 [432]	6½ [168]
3 by 2"O	3 [76]	4 [102]	4¾ [121]	6½ [165]	11¾ [298]	7 [178]	3 [76]	9 [229]	4 [102]
4 by 2"O	3 [76]	4 [102]	5 [127]	7 [178]	12 [305]	7 [178]	3 [76]	9 [229]	4½ [114]
4 by 3"O	3¼ [83]	4 [102]	5½ [140]	7¼ [184]	13 [330]	7½ [191]	3½ [89]	10 [254]	4½ [114]
5 by 3"O	3¼ [83]	4 [102]	5½ [140]	7¾ [197]	13 [330]	7½ [191]	3½ [89]	10 [254]	5 [114]
5 by 4"O	3½ [89]	4 [102]	6 [152]	8 [203]	14 [356]	8 [203]	4 [102]	11 [279]	5 [127]
6 by 4"O	3½ [89]	4 [102]	6 [152]	8½ [216]	14 [356]	8 [203]	4 [102]	11 [279]	5½ [140]
8 by 4"O	3½ [89]	5¾ [146]	6¾ [171]	9½ [241]	16½ [419]	9¾ [248]	4 [102]	13 [330]	6½ [165]
8 by 6"O	3½ [89]	5¾ [146]	7¾ [197]	9½ [241]	18½ [470]	10¾ [273]	5 [127]	15 [381]	6½ [165]

<sup>A</sup>\* indicates this item is made in extra heavy.

O indicates this item is made in service weight.

<sup>B</sup> For details of hubs and spigots, see Table 1. For details of side inlets see Fig. 3.

**ASTM A 74**

**TABLE 21 Dimensions of Sanitary T Branches, Cleanout Plug on Main**

NOTE 1—1 in. = 25.4 mm.

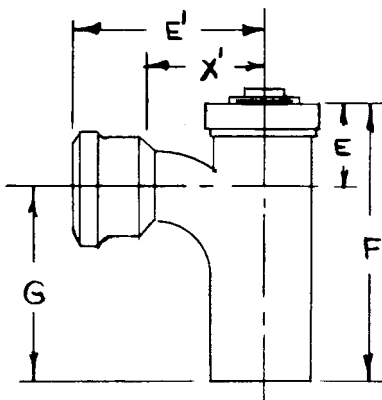

Size, in., Availability <sup>A</sup>	Dimensions in in. <sup>B</sup>					Minimum I.P.S. Tapping <sup>C</sup>
	E	E'	F	G	X'	
2*O	3 [76]	5¼ [133]	9¼ [235]	6¼ [159]	2¾ [70]	1½ [38]
3*O	3¾ [92]	6¾ [171]	11⅞ [283]	7½ [191]	4 [102]	2½ [64]
4*O	4⅞ [105]	7½ [191]	12⅞ [308]	8 [203]	4½ [114]	3½ [89]

<sup>A</sup> \* indicates this item is made in extra heavy.

O indicates this item is made in service weight.

<sup>B</sup> For details of hubs and spigots see Table 1. For dimensions not given in this table, see Table 20.

<sup>C</sup> For details of tapping bosses, see Table 42; and for details of screw plugs, see Table 38.



**ASTM A 74**

**TABLE 22 Dimensions of Sanitary T Branches, Tapped, Single and Double**

NOTE 1—1 in. = 25.4 mm.

NOTE 2—Dimension X is the laying length.

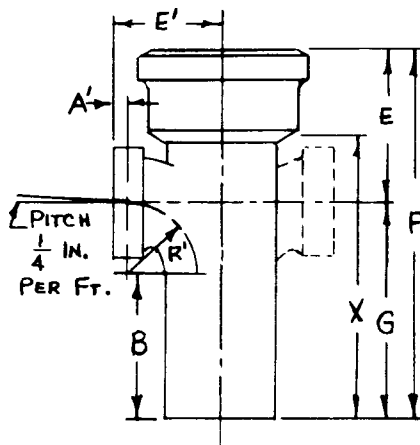

Size, in., <sup>A</sup> Availability <sup>B</sup>	Dimensions in in. <sup>C</sup>							
	A'	B	E	E'	F	G	R'	X
2 by 2"O	1 <sup>3</sup> / <sub>16</sub> [21]	4 [102]	4 <sup>1</sup> / <sub>2</sub> [114]	3 <sup>1</sup> / <sub>16</sub> [78]	10 <sup>1</sup> / <sub>2</sub> [267]	6 <sup>1</sup> / <sub>4</sub> [159]	2 <sup>1</sup> / <sub>4</sub> [57]	8 [203]
3 by 2"O	1 <sup>3</sup> / <sub>16</sub> [21]	4 <sup>3</sup> / <sub>4</sub> [121]	4 <sup>3</sup> / <sub>4</sub> [121]	3 <sup>9</sup> / <sub>16</sub> [90]	11 <sup>3</sup> / <sub>4</sub> [298]	7 [178]	2 <sup>1</sup> / <sub>4</sub> [57]	9 [229]
4 by 2"O	1 <sup>3</sup> / <sub>16</sub> [21]	4 <sup>3</sup> / <sub>4</sub> [121]	5 [127]	4 <sup>1</sup> / <sub>16</sub> [103]	12 [305]	7 [178]	2 <sup>1</sup> / <sub>4</sub> [57]	9 [229]
5 by 2"O	1 <sup>3</sup> / <sub>16</sub> [21]	4 <sup>3</sup> / <sub>4</sub> [121]	5 [127]	4 <sup>9</sup> / <sub>16</sub> [116]	12 [305]	7 [178]	2 <sup>1</sup> / <sub>4</sub> [57]	9 [229]
6 by 2"O	1 <sup>3</sup> / <sub>16</sub> [21]	4 <sup>3</sup> / <sub>4</sub> [121]	5 [127]	5 <sup>1</sup> / <sub>16</sub> [129]	12 [305]	7 [178]	2 <sup>1</sup> / <sub>4</sub> [57]	9 [229]
2"O <sup>D</sup>	...	4 <sup>1</sup> / <sub>2</sub> [114]	...	2 <sup>3</sup> / <sub>16</sub> [71]	...	...	1 <sup>3</sup> / <sub>4</sub> [44]	...
3"O <sup>D</sup>	...	5 <sup>1</sup> / <sub>4</sub> [133]	...	3 <sup>5</sup> / <sub>16</sub> [84]	...	...	1 <sup>3</sup> / <sub>4</sub> [44]	...
4"O <sup>D</sup>	...	5 <sup>1</sup> / <sub>4</sub> [133]	...	3 <sup>3</sup> / <sub>16</sub> [97]	...	...	1 <sup>3</sup> / <sub>4</sub> [44]	...
5O <sup>D</sup>	...	5 <sup>1</sup> / <sub>4</sub> [133]	...	4 <sup>5</sup> / <sub>16</sub> [110]	...	...	1 <sup>3</sup> / <sub>4</sub> [44]	...

Size, in., <sup>A</sup> Availability <sup>B</sup>	Dimensions in in. <sup>C</sup>							
	A'	B	E	E'	F	G	R'	X
Double:								
2 by 2"O	1 <sup>3</sup> / <sub>16</sub> [21]	4 [102]	4 <sup>1</sup> / <sub>2</sub> [114]	3 <sup>1</sup> / <sub>16</sub> [78]	10 <sup>1</sup> / <sub>2</sub> [267]	6 <sup>1</sup> / <sub>4</sub> [159]	2 <sup>1</sup> / <sub>4</sub> [57]	8 [203]
3 by 2"O	1 <sup>3</sup> / <sub>16</sub> [21]	4 <sup>3</sup> / <sub>4</sub> [121]	4 <sup>3</sup> / <sub>4</sub> [121]	3 <sup>9</sup> / <sub>16</sub> [90]	11 <sup>3</sup> / <sub>4</sub> [298]	7 [178]	2 <sup>1</sup> / <sub>4</sub> [57]	9 [229]
4 by 2"O	1 <sup>3</sup> / <sub>16</sub> [21]	4 <sup>3</sup> / <sub>4</sub> [121]	5 [127]	4 <sup>1</sup> / <sub>16</sub> [103]	12 [305]	7 [178]	2 <sup>1</sup> / <sub>4</sub> [57]	9 [229]
2"O <sup>D</sup>	...	4 <sup>1</sup> / <sub>2</sub> [114]	...	2 <sup>3</sup> / <sub>16</sub> [71]	...	...	1 <sup>3</sup> / <sub>4</sub> [44]	...
3"O <sup>D</sup>	...	5 <sup>1</sup> / <sub>4</sub> [133]	...	3 <sup>5</sup> / <sub>16</sub> [84]	...	...	1 <sup>3</sup> / <sub>4</sub> [44]	...
4"O <sup>D</sup>	...	5 <sup>1</sup> / <sub>4</sub> [133]	...	3 <sup>3</sup> / <sub>16</sub> [97]	...	...	1 <sup>3</sup> / <sub>4</sub> [44]	...

<sup>A</sup> All sizes of branches are furnished with 1/4 and 1/2 in. tappings, in addition to the 2 in. tapping.

<sup>B</sup> \* indicates this item is made in extra heavy.

O indicates this item is made in service weight.

<sup>C</sup> For details of hubs and spigots, see Table 1. For details of tapping bosses, see Table 42.

<sup>D</sup> Dimensions for 1/4 in. and 1/2 in. tapping only.

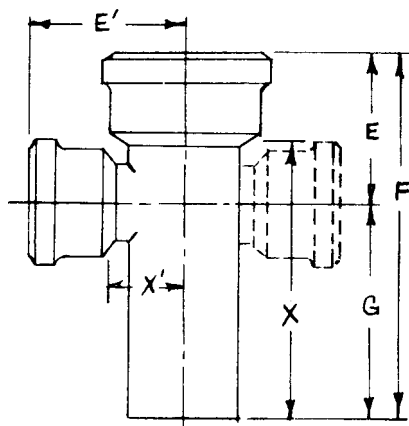

**TABLE 23 Dimensions of T Branches, Single and Double**

NOTE 1—1 in. = 25.4 mm.

NOTE 2—T branches are intended for venting and cleanout purposes only, and branch openings are not intended for use as waste inlets.

NOTE 3—Dimensions X and X' are laying lengths.



Size, in., Availability <sup>A</sup>	Dimensions in in. <sup>B</sup>					
	E	E'	F	G	X	X'
Single:						
2"O	4¼ [108]	4¼[108]	10½ [267]	6¼ [159]	8 [203]	1¾ [44]
3"O	5¼ [133]	5¼[133]	12¾ [324]	7½ [191]	10 [254]	2½ [64]
4"O	6 [152]	6 [152]	14 [356]	8 [203]	11 [279]	3 [76]
5"O	6½ [165]	6½[165]	15 [381]	8½ [216]	12 [306]	3½ [89]
6"O	7 [178]	7 [178]	16 [406]	9 [229]	13 [330]	4 [102]
3 by 2"O	4¾ [121]	5 [127]	11¾ [298]	7 [178]	9 [229]	2½ [64]
4 by 2"O	5 [127]	5½ [140]	12 [305]	7 [178]	9 [229]	3 [76]
4 by 3"O	5½ [140]	5¾[146]	13 [330]	7½ [191]	10 [254]	3 [76]
5 by 2"O	5 [127]	6 [152]	12 [305]	7 [178]	9 [229]	3½[89]
5 by 3"O	5½ [140]	6¼[159]	13 [330]	7½ [191]	10 [254]	3½ [89]
5 by 4"O	6 [152]	6¼ [159]	14 [356]	8 [203]	11 [279]	3½ [89]
6 by 2"O	5 [127]	6½ [165]	12 [305]	7 [178]	9 [229]	4 [102]
6 by 3"O	5½ [140]	6¾[171]	13 [330]	7½ [191]	10 [254]	4 [102]
6 by 4"O	6 [152]	7 [178]	14 [356]	8 [203]	11 [279]	4 [102]
6 by 5"O	6½ [165]	7 [178]	15 [381]	8½ [216]	12 [305]	4 [102]
Size, in., Availability <sup>A</sup>	Dimensions in in. <sup>B</sup>					
E	E'	F	G	X	X'	
Double:						
2"O	4¼ [108]	4¼[108]	10½ [267]	6¼ [159]	8 [203]	1¾ [44]
3"O	5¼ [133]	5¼[133]	12¾ [324]	7½ [191]	10 [254]	2½ [64]
4"O	6 [152]	6 [152]	14 [356]	8 [203]	11 [279]	3 [76]
3 by 2"O	4¾ [121]	5 [127]	11¾ [298]	7 [178]	9 [229]	2½ [64]
4 by 2"O	5 [127]	5½ [140]	12 [305]	7 [178]	9 [229]	3 [76]
4 by 3"O	5½ [140]	5¾[146]	13 [330]	7½ [191]	10 [254]	3 [76]

<sup>A</sup> \* indicates this item is made in extra heavy.

O indicates this item is made in service weight.

<sup>B</sup> For details of hubs and spigots, see Table 1.

**ASTM A 74**

**TABLE 24 Dimensions of Tapped T Branches, Single and Double**

NOTE 1—1 in. = 25.4 mm.

NOTE 2—Tapped T branches are intended for venting and cleanout purposes only, and branch openings are not intended for use as waste inlets.

NOTE 3—Dimension X is the laying length.

NOTE 4—Dimensions given apply to branches tapped 1¼, 1½ and 2 in., I.P.S.

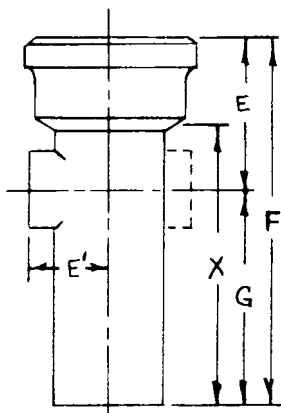

Size, in., Availability <sup>A</sup>	Dimensions in in. <sup>B</sup>					I.P.S. Tapping
	E	E'	F	G	X	
2"O	4¼ [108]	2 [51]	10½ [267]	6¼ [159]	8 [203]	1¼-1½-2 [32-38-51]
3"O	4¾ [121]	2½ [64]	11¾ [298]	7 [178]	9 [229]	1¼-1½-2 [32-38-51]
4"O	5 [127]	3 [76]	12 [305]	7 [178]	9 [229]	1¼-1½-2 [32-38-51]
5"O	5 [127]	3½ [89]	12 [305]	7 [178]	9 [229]	1¼-1½-2 [32-38-51]
6O	5 [127]	4 [102]	12 [305]	7 [178]	9 [229]	1¼-1½-2 [32-38-51]
4 by 3"O	6 [152]	3 [76]	14 [356]	8 [203]	11 [279]	3 [76]
5 by 4"O	6½ [165]	3½ [89]	15 [381]	8½ [215]	12 [305]	4 [102]
6 by 4"O	7 [178]	4 [102]	16 [406]	9 [229]	13 [330]	4 [102]

Size, in., Availability <sup>A</sup>	Dimensions in in. <sup>B</sup>					I.P.S. Tapping
	E	E'	F	G	X	
Double:						
2O	4¼ [108]	2 [51]	10½ [267]	6¼ [159]	8 [103]	1¼-1½-2 [32-38-51]
3"O	4¾ [121]	2½ [64]	11¾ [298]	7 [178]	9 [229]	1¼-1½-2 [32-38-51]
4"O	5 [127]	3 [76]	12 [305]	7 [178]	9 [229]	1¼-1½-2 [32-38-51]

<sup>A</sup>\* indicates this item is made in extra heavy.

O indicates this item is made in service weight.

<sup>B</sup> For details of hubs and spigots, see Table 1. For details of tapping bosses, see Table 42.

**ASTM A 74**

**TABLE 25 Dimensions of Horizontal Twin Tapped T**

NOTE 1—1 in. = 25.4 mm.

NOTE 2—Dimension X is the laying length.

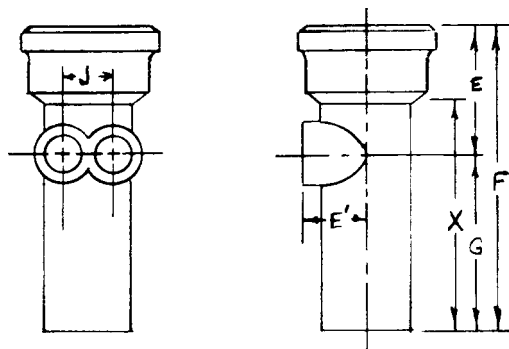

Size, in., Availability <sup>A</sup>	Dimensions in in. <sup>B</sup>						I.P.S. Tapping
	E	E'	F	G	J	X	
2*O	4¼ [108]	2 [51]	10½ [267]	6¼ [159]	2¾ [70]	8 [203]	1¼-1½ [32-38]
3*O	4¾ [121]	2½ [64]	11¾ [298]	7 [178]	2¾ [70]	9 [229]	1¼-1½ [32-38]
4*O	5 [127]	3 [76]	12 [305]	7 [178]	2¾ [70]	9 [229]	1¼-1½-2 [32-38-51]

<sup>A</sup>For details of hubs and spigots, see Table 1. For details of tapping bosses, see Table 42.

<sup>B</sup>\* indicates this item is made in extra heavy.

O indicates this item is made in service weight.

**TABLE 26 Dimensions of T Branch Cleanout with Screw Plug**

NOTE 1—1 in. = 25.4 mm.

NOTE 2—Dimension X is the laying length.

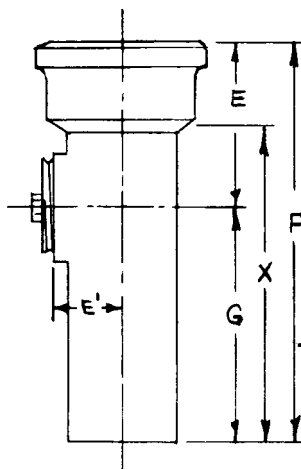

Size, in., Availability <sup>A</sup>	Dimensions in in. <sup>B</sup>					I.P.S. Tapping
	E	E'	F	G	X	
2 by 1½*O	4¼ [108]	2 [51]	10½ [267]	6¼ [159]	8 [203]	1½ [38]
3 by 2½*O	5¼ [133]	2½ [64]	12¾ [324]	7½ [191]	10 [254]	2½ [64]
4 by 3½*O	6 [152]	3 [76]	14 [356]	8 [103]	11 [279]	3½ [89]
5 by 4*O	6½ [165]	3½ [89]	15 [381]	8½ [216]	12 [305]	4 [102]
6 by 4*O	7 [178]	4 [102]	16 [406]	9 [229]	13 [330]	4 [102]

<sup>A</sup>\* indicates this item is made in extra heavy.

O indicates this item is made in service weight.

<sup>B</sup>For details of hubs and spigots, see Table 1. For details of tapping bosses, see Table 42.

**ASTM A 74**

**TABLE 27 Dimensions of Vent Branches, Single**

NOTE 1—1 in. = 25.4 mm.

NOTE 2—Dimension X is the laying length.

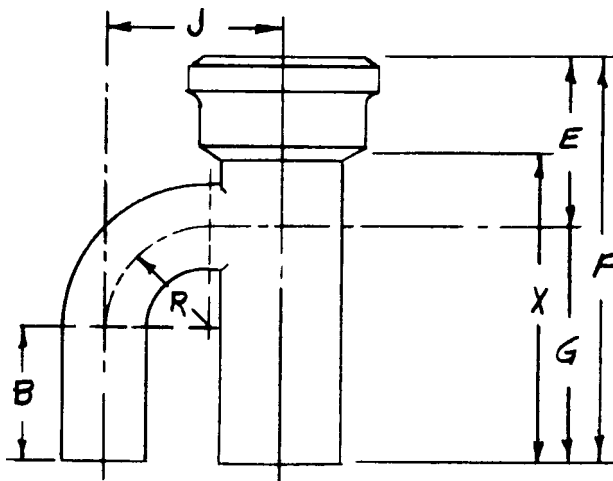

Size, in. Availability <sup>A</sup>	Dimensions in in. <sup>B</sup>						
	B	E	F	G	J	R'	X
2"O	3¼ [83]	4¼ [108]	10½ [267]	6¼ [159]	4½ [114]	3 [76]	8 [203]
3"O	4 [102]	5¼ [134]	12¾ [324]	7½ [191]	5½ [140]	3½ [89]	10 [254]
4"O	4 [102]	6 [152]	14 [356]	8 [203]	6½ [165]	4 [102]	11 [279]
3 by 2O	4 [102]	4¾ [121]	11¾ [298]	7 [178]	5 [127]	3 [76]	9 [229]
4 by 2"O	4 [102]	5 [127]	12 [305]	7 [178]	5½ [140]	3 [76]	9 [229]
4 by 3"O	4 [102]	5½ [140]	13 [330]	7½ [191]	6 [152]	3½ [89]	10 [254]

<sup>A</sup> \* indicates this item is made in extra heavy.

O indicates this item is made in service weight.

<sup>B</sup> For details of hubs and spigots, see Table 1.

**ASTM A 74**

**TABLE 28 Dimensions of One-Eighth Bend Offset (2 in., 3 in., 4 in., 5 in., and 6 in.)**

NOTE 1—1 in. = 25.4 mm.

NOTE 2—Dimension X is the laying length.

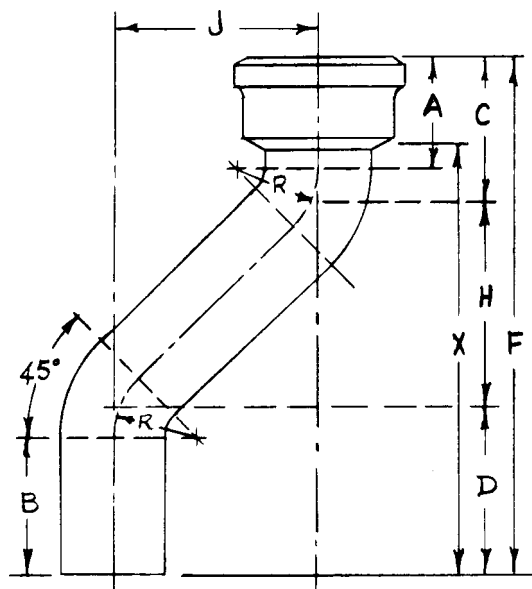

**One-Eighth Bend Offset (2 in.):**

Size, in., Availability <sup>A</sup>	Dimensions in in. <sup>B</sup>								
	A'	B	E	E'	F	G	R'	X	X'
2 by 2O	2¾ [70]	3½ [89]	3½ [89]	4¼ [108]	9¾ [248]	2 [51]	2 [51]	2 [51]	7¼ [184]
2 by 4O	2¾ [70]	3½ [89]	3½ [89]	4¼ [108]	11¾ [298]	4 [102]	4 [102]	2 [51]	9¼ [235]
2 by 6O	2¾ [70]	3½ [89]	3½ [89]	4¼ [108]	13¾ [349]	6 [152]	6 [152]	2 [51]	11¼ [286]
2 by 8O	2¾ [70]	3½ [89]	3½ [89]	4¼ [108]	15¾ [400]	8 [203]	8 [203]	2 [51]	13¼ [337]
2 by 10O	2¾ [70]	3½ [89]	3½ [89]	4¼ [108]	17¾ [451]	10 [254]	10 [254]	2 [51]	15¼ [387]
2 by 12O	2¾ [70]	3½ [89]	3½ [89]	4¼ [108]	19¾ [502]	12 [305]	12 [305]	2 [51]	17¼ [438]
2 by 18O	2¾ [70]	3½ [89]	3½ [89]	4¼ [108]	25¾ [654]	18 [457]	18 [457]	2 [51]	23¼ [591]
<b>One-Eighth Bend Offset (3 in.):</b>									
3 by 2°O	3¼ [83]	4 [102]	4¼ [108]	5 [127]	11¼ [286]	2 [51]	2 [51]	2½ [64]	8½ [216]
3 by 4°O	3¼ [83]	4 [102]	4¼ [108]	5 [127]	13¼ [337]	4 [102]	4 [102]	2½ [64]	10½ [267]
3 by 6°O	3¼ [83]	4 [102]	4¼ [108]	5 [127]	15¼ [387]	6 [152]	6 [152]	2½ [64]	12½ [318]
3 by 8°O	3¼ [83]	4 [102]	4¼ [108]	5 [127]	17¼ [438]	8 [203]	8 [203]	2½ [64]	14½ [368]
3 by 10O	3¼ [83]	4 [102]	4¼ [108]	5 [127]	19¼ [489]	10 [254]	10 [254]	2½ [64]	16½ [419]
3 by 12O	3¼ [83]	4 [102]	4¼ [108]	5 [127]	21¼ [540]	12 [305]	12 [305]	2½ [64]	18½ [469]
3 by 14O	3¼ [83]	4 [102]	4¼ [108]	5 [127]	23¼ [591]	14 [356]	14 [356]	2½ [64]	20½ [521]
3 by 18°	3¼ [83]	4 [102]	4¼ [108]	5 [127]	27¼ [692]	18 [57]	18 [457]	2½ [64]	24½ [622]
<b>One-Eighth Bend Offset (4 in.):</b>									
4 by 2°O	3½ [89]	4 [102]	4¾ [121]	5¼ [133]	12 [305]	2 [51]	2 [51]	3 [76]	9 [229]
4 by 4°O	3½ [89]	4 [102]	4¾ [121]	5¼ [133]	14 [356]	4 [102]	4 [102]	3 [76]	11 [279]
4 by 6°O	3½ [89]	4 [102]	4¾ [121]	5¼ [133]	16 [406]	6 [152]	6 [152]	3 [76]	13 [330]
4 by 8°O	3½ [89]	4 [102]	4¾ [121]	5¼ [133]	18 [456]	8 [203]	8 [203]	3 [76]	15 [381]
4 by 10°O	3½ [89]	4 [102]	4¾ [121]	5¼ [133]	20 [508]	10 [254]	10 [254]	3 [76]	17 [432]
4 by 12°O	3½ [89]	4 [102]	4¾ [121]	5¼ [133]	22 [559]	12 [305]	12 [305]	3 [76]	19 [483]
4 by 14O	3½ [89]	4 [102]	4¾ [121]	5¼ [133]	24 [610]	14 [356]	14 [356]	3 [76]	21 [533]
4 by 16O	3½ [89]	4 [102]	4¾ [121]	5¼ [133]	26 [660]	16 [406]	16 [406]	3 [76]	23 [584]
4 by 18°O	3½ [89]	4 [102]	4¾ [121]	5¼ [133]	28 [711]	18 [457]	18 [457]	3 [76]	25 [635]

<sup>A</sup>\* indicates this item is made in extra heavy.

O indicates this item is made in service weight.

<sup>B</sup> For details of hubs and spigots, see Table 1.

**ASTM A 74**

**TABLE 29 Dimensions of Double Hub and Long Double Hub**

NOTE 1—1 in. = 25.4 mm.

NOTE 2—Dimension *X* is the laying length.

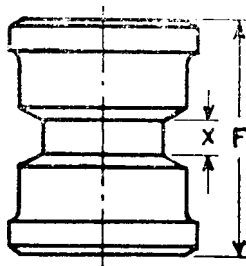

Double Hub:

Size, in. <sup>A</sup> Availability <sup>B</sup>	<i>F</i> , in.	<i>X</i> , in.	Size, in. <sup>A</sup>	<i>F</i> , in.	<i>X</i> , in.
2*O	6 [152]	1 [25]	8 [203]	8¼ [210]	1¼ [32]
3*O	6½ [165]	1 [25]	10 [254]	8¼ [210]	1¼ [32]
4*O	7 [178]	1 [25]	12 [305]	10 [254]	1½ [38]
5*O	7 [178]	1 [25]	15 [381]	10 [254]	1½ [38]
6*O	7 [178]	1 [25]			

Long Double Hubs:

Size, in. <sup>A</sup>	<i>F</i> , in.	<i>X</i> , in.
2 by 30*O	30 [762]	25 [635]
3 by 30*O	30 [762]	24½ [622]
4 by 30*O	30 [762]	24 [610]

<sup>A</sup> For details of hubs and spigots, see Table 1.

<sup>B</sup> \* indicates this item is made in extra heavy.

O indicates this item is made in service weight.



**ASTM A 74**

**TABLE 30 Dimensions of Reducers**

NOTE 1—1 in. = 25.4 mm.

NOTE 2—Dimension X is the laying length.

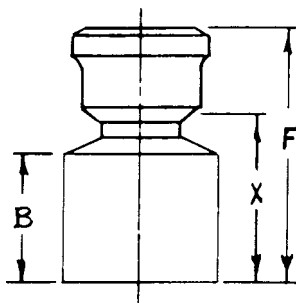

Size, in. Availability <sup>A</sup>	B, in.	F, in.	X, in.	Size, in. Availability <sup>B</sup>	B, in.	F, in.	X, in.
3 by 2*O	3¾ [95]	7¼ [184]	4¾ [121]	8 by 6*O	4½ [114]	9 [229]	6 [152]
4 by 2*O	4 [102]	7½ [191]	5 [127]	10 by 4*O	4½ [114]	9 [229]	6 [152]
4 by 3*O	4 [102]	7¾ [197]	5 [127]	10 by 5*O	4½ [114]	9 [229]	6 [152]
5 by 2*O	4 [102]	7½ [191]	5 [127]	10 by 6*O	4½ [114]	9 [229]	6 [152]
5 by 3*O	4 [102]	7¾ [197]	5 [127]	10 by 8*O	4½ [114]	9½ [241]	6 [152]
5 by 4*O	4 [102]	8 [203]	5 [127]	12 by 4*O	5¼ [133]	9½ [241]	6½ [165]
6 by 2*O	4 [102]	7½ [192]	5 [127]	12 by 5*O	5¼ [133]	9½ [241]	6½ [165]
6 by 3*O	4 [102]	7¾ [197]	5 [127]	12 by 6*O	5¼ [133]	9½ [241]	6½ [165]
6 by 4*O	4 [102]	8 [203]	5 [127]	12 by 8*O	5¼ [133]	10 [254]	6½ [165]
6 by 5*O	4 [102]	8 [203]	5 [127]	12 by 10*O	5¼ [133]	10 [254]	6½ [165]
8 by 2*O	4½ [114]	8½ [216]	6 [152]	15 by 6*O	5¼ [133]	9½ [241]	6½ [165]
8 by 3*O	4½ [114]	8¾ [222]	6 [152]	15 by 8*O	5¼ [133]	10 [254]	6½ [165]
8 by 4*O	4½ [114]	9 [229]	6 [152]	15 by 10*O	5¼ [133]	10 [254]	6½ [165]
8 by 5*O	4½ [114]	9 [229]	6 [152]	15 by 12*O	5¼ [133]	10¾ [273]	6½ [165]

<sup>A</sup>\* indicates this item is made in extra heavy.

O indicates this item is made in service weight.

<sup>B</sup> For details of hubs and spigots, see Table 1.

**ASTM A 74**

**TABLE 31 Dimensions of Increaser**

NOTE 1—1 in. = 25.4 mm.

NOTE 2—Dimension X is the laying length.

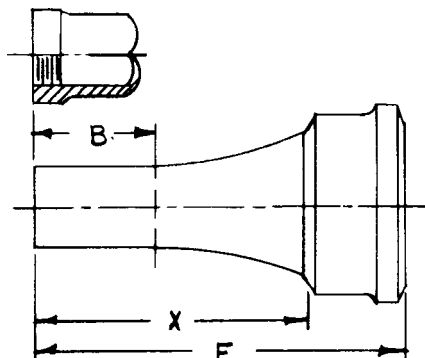

Size, in. Availability <sup>A</sup>	B, <sup>B</sup> in.	F, <sup>B</sup> in.	S, <sup>B</sup> in.
2 by 3°O	4 [102]	11¾ [298]	9 [229]
2 by 4°O	4 [102]	12 [305]	9 [229]
3 by 4°O	4 [102]	12 [305]	9 [229]
3 by 5°O	4 [102]	12 [305]	9 [229]
3 by 6°O	4 [102]	12 [305]	9 [229]
4 by 5°O	4 [102]	12 [305]	9 [229]
4 by 6°O	4 [102]	12 [305]	9 [229]
4 by 8°O	4 [102]	15½ [394]	12 [305]

<sup>A</sup>\* indicates this item is made in extra heavy.

O indicates this item is made in service weight.

<sup>B</sup>For details of hubs and spigots, see Table 1.

**TABLE 32 Dimensions of Long Increasers, Spigot and Tapped**

NOTE 1—1 in. = 25.4 mm.

NOTE 2—First size given for long increasers is spigot size. First size given for long increasers, tapped, is tapping size.

NOTE 3—All markings shall be on small end and in space indicated by dimension C.

NOTE 4—Dimension L is the laying length.

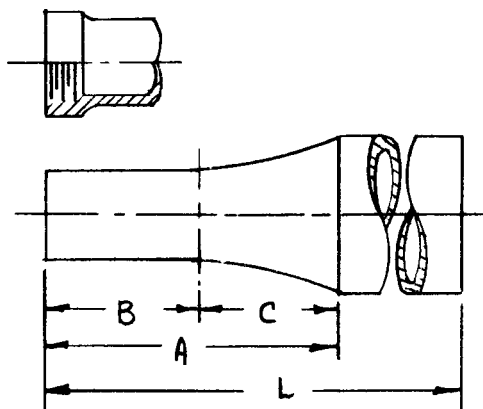

Size, in. Availability <sup>A</sup>	Dimensions in in. <sup>B</sup>			
	A	B	C	L
2 by 4 by 24°O	8½ [216]	4 [102]	4½ [114]	24 [610]
2 by 4 by 30°O	8½ [216]	4 [102]	4½ [114]	30 [762]
3 by 4 by 24O	8½ [216]	4 [102]	4½ [114]	24 [610]

<sup>A</sup>\* indicates this item is made in extra heavy.

O indicates this item is made in service weight.

<sup>B</sup>For details of hubs and spigots, see Table 1. For details of tapping bosses, see Table 42.

**ASTM A 74**

**TABLE 33 Dimensions of S Traps**

NOTE 1—1 in. = 25.4 mm.

NOTE 2—A minimum water seal of 2 in. is provided for the 2-in. size, and 2½ in. for sizes 3 and 4 in.

NOTE 3—Dimensions *J* and *X* are laying lengths.

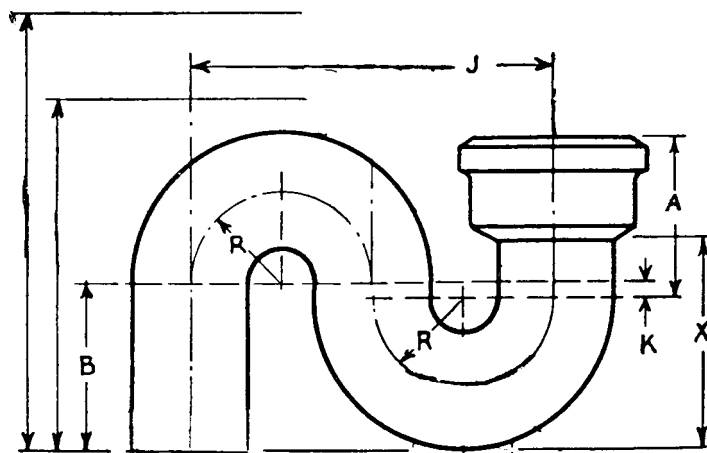

Size, in. Trap by Vent	Availability <sup>A</sup>	Dimensions in in. <sup>B</sup>					
		A	B	J	K	R	X
2 by 2	*O	3 [76]	3½[89]	8 [203]	...	2 [51]	4 [102]
4 by 4	*O	5½ [140]	5½ [140]	12 [305]	½ [13]	3 [76]	7½ [191]

<sup>A</sup>\* indicates this item is made in extra heavy.

O indicates this item is made in service weight.

<sup>B</sup> For details of hubs and spigots, see Table 1. For details of tapping bosses, see Table 41.

**TABLE 34 Dimensions of P Traps with Cleanout**

NOTE 1—1 in. = 25.4 mm.

NOTE 2—A minimum water seal of 2 in. is provided for the 2-in. size; of 2½ in. for sizes 3 to 6 in., inclusive.

NOTE 3—Dimensions *D* and *X* are laying lengths. Dimension *X* is measured below the horizontal center line.

NOTE 4—Traps with tapped cleanout shall have tappings of sizes indicated below.

NOTE 5—Tap at position *Z* shall be specified as right side, left side, or bottom.

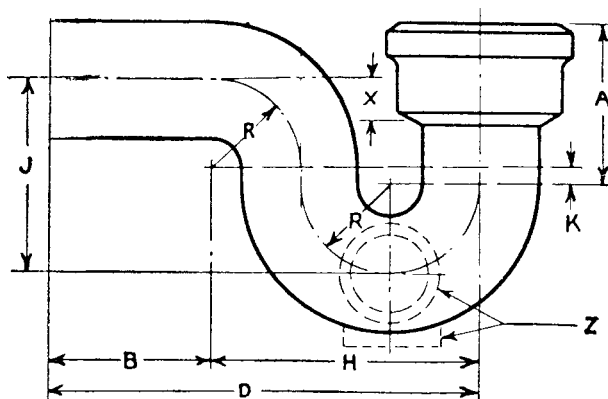

Size, in.	Availability <sup>A</sup>	Dimensions in in. <sup>B</sup>									
		A	B	C	D	F	H	J	K	R	X
2	*O	3 [76]	3½[89]	4 [102]	9½ [241]	4½[114]	6 [152]	4 [102]	..	2 [51]	1½ [38]
3	*O	4½ [114]	4½ [114]	5 [140]	12 [305]	5¼[133]	7½ [191]	5⅓ [135]	½ [13]	2½ [64]	1¼ [32]
4	*O	5½ [140]	5 [140]	6 [152]	14 [356]	6 [152]	9 [229]	6½ [165]	½[13]	3 [76]	1 [25]
		Size, in.								IPS Tapping at Z, in.	
		2								1¼ [32]	
		3								1½ [38]	
		4								3 [76]	

<sup>A</sup>\* indicates this item is made in extra heavy.

O indicates this item is made in service weight.

<sup>B</sup> For details of hubs and spigots, see Table 1. For details of tapping bosses, see Table 42.

**ASTM A 74**

**TABLE 35 Dimensions of Plain P Trap**

NOTE 1—1 in. = 25.4 mm.

NOTE 2—A minimum water seal of 2 in. is provided for the 2-in. size, of 2½ in. for sizes 3 to 6 in., inclusive.

NOTE 3—Dimensions *D* and *X* are laying lengths. Dimension *X* is measured below the horizontal center line on sizes 5 by 5 in. and smaller.

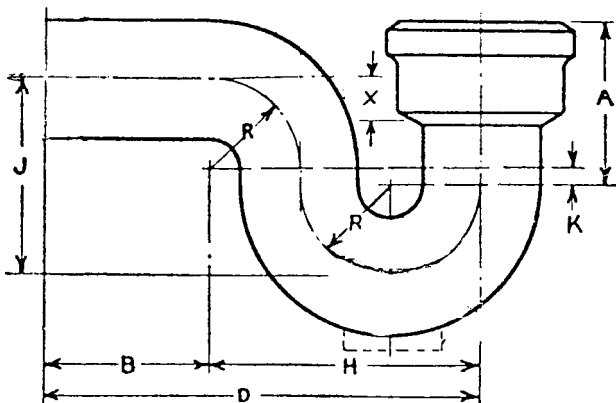

Size, in. Trap by Vents	Availability <sup>A</sup>	Dimensions in in. <sup>B</sup>							
		A	B	D	H	J	K	R	X
2	*O	3 [76]	3½ [89]	9½ [241]	6 [152]	4 [102]	...	2 [51]	1½ [38]
3	*O	4½ [114]	4½ [114]	12 [305]	7½ [191]	5½ [135]	½ [13]	2½ [64]	1¼ [32]
4	*O	5½ [140]	5 [127]	14 [356]	9 [229]	6½ [165]	½ [13]	3 [76]	1 [25]
5	*O	6½ [165]	5 [127]	15½ [394]	10½ [267]	7½ [191]	½ [13]	3½ [89]	½ [13]
6	*O	7½ [191]	5 [127]	17 [432]	12 [305]	8½ [216]	½ [13]	4 [102]	...

<sup>A</sup>\* indicates this item is made in extra heavy.

O indicates this item is made in service weight.

<sup>B</sup> For details of hubs and spigots, see Table 1. For details of topping bosses, see Table 41.

**TABLE 36 Dimensions of Deep Seal P Trap**

NOTE 1—1 in. = 25.4 mm.

NOTE 2—Dimension *D* is the laying length.

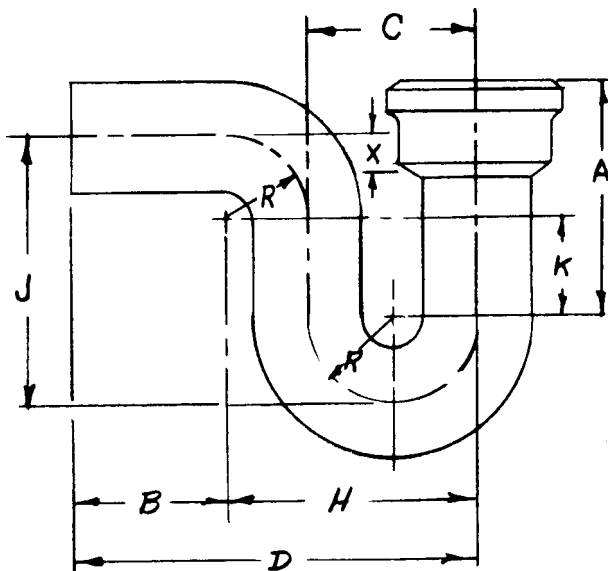

Size, in., Availability <sup>A</sup>	Dimensions in in. <sup>B</sup>								
	A	B	C	D	H	J	K	R	X
2*O	5 [127]	3½ [89]	4 [102]	9½ [241]	6 [152]	6 [152]	2 [51]	2 [51]	1½ [38]
3*O	6 [152]	4½ [114]	5 [127]	12 [305]	7½ [191]	7 [178]	2 [51]	2½ [64]	1¼ [32]
4*O	7 [178]	5 [127]	6 [152]	14 [356]	9 [229]	8 [203]	2 [51]	3 [76]	1¼ [32]

<sup>A</sup>\* indicates this item is made in extra heavy.

O indicates this item is made in service weight.

<sup>B</sup> For details of hubs and spigots, see Table 1.

**ASTM A 74**

**TABLE 37 Dimensions of Running Traps With or Without Single or Double Vents and Cleanout**

NOTE 1—1 in. = 25.4 mm.

NOTE 2—A minimum water seal of 2 in. is provided for the 2-in. size; of 2½ in. for sizes 3 to 6 in., inclusive; of 3 in. for sizes 8 to 12 in., inclusive; and of 3½ in. for the 15-in. size.

NOTE 3—Dimensions X and X' are laying lengths.

NOTE 4—For traps with tapping at Z, see Table 34, Note 3.

NOTE 5—Tap at position Z shall be specified as right side, left side, or bottom.

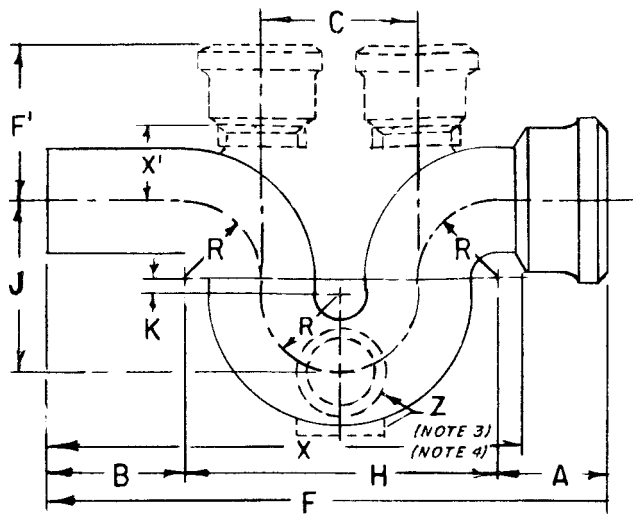

Size, in. Trap by Vent	Dimensions in in. <sup>A</sup>										
	A	B	C	F	F'	H	J	K	R	X	X'
2 by 2	3 [76]	3½ [89]	4 [102]	14½ [368]	4½ [114]	8 [203]	4 [102]	...	2 [51]	12 [305]	2 [51]
3 by 3	3¼ [83]	4½ [114]	5 [127]	17¾ [451]	5¼ [133]	10 [254]	5½ [140]	½ [13]	2½ [64]	15 [381]	2½ [64]
4 by 4	3½ [83]	5 [127]	6 [152]	20½ [521]	6 [152]	12 [305]	6½ [165]	½ [13]	3 [76]	17½ [445]	3 [76]
5 by 4	3½ [83]	5 [127]	7 [178]	22½ [572]	6½ [165]	14 [356]	7½ [191]	½ [13]	3½ [89]	19½ [495]	3½ [89]
5 by 5	3½ [83]	5 [127]	7 [178]	22½ [572]	6½ [165]	14 [356]	7½ [191]	½ [13]	3½ [89]	19½ [495]	3½ [89]
6 by 4	3½ [83]	5 [127]	8 [203]	24½ [622]	7 [178]	16 [406]	8½ [216]	½ [13]	4 [102]	21½ [546]	4 [102]
6 by 6	3½ [83]	5 [127]	8 [203]	24½ [622]	7 [178]	16 [406]	8½ [216]	½ [13]	4 [102]	21½ [546]	4 [102]
8 by 4	4½ [105]	7 [178]	10 [254]	31½ [791]	8¼ [210]	20 [508]	11 [279]	1 [25]	5 [127]	27½ [702]	5¼ [133]
8 by 6	4½ [105]	7 [178]	10 [254]	31½ [791]	8¼ [210]	20 [508]	11 [279]	1 [25]	5 [127]	27½ [702]	5¼ [133]
10 by 6	4½ [105]	7 [178]	12 [305]	35½ [892]	9¼ [235]	24 [610]	13 [330]	1 [25]	6 [152]	31½ [803]	6¼ [159]
10 by 8	4½ [105]	7 [178]	12 [305]	35½ [892]	9¼ [235]	24 [610]	13 [330]	1 [25]	6 [152]	31½ [803]	6¼ [159]
12 by 6	5 [127]	8 [203]	15 [381]	43 [1092]	10¼ [260]	30 [762]	15 [381]	...	7½ [191]	38¾ [984]	7¼ [184]
12 by 10	5 [127]	8 [203]	15 [381]	43 [1092]	10¼ [260]	30 [762]	15 [381]	...	7½ [191]	38¾ [984]	7¼ [184]
15 by 12	5 [127]	8 [203]	18½ [470]	50 [1270]	13 [330]	37 [940]	18½ [470]	...	9¼ [235]	45¾ [1162]	8¾ [222]

Running Trap with Single Vent	Running Trap with Double Vent	Running Trap with Cleanout	Running Trap with Single Vent and Cleanout	Running Trap with Double Vent and Cleanout	Running Trap Plain
3 by 3 <sup>O</sup> <sup>B</sup>	2 by 2 <sup>O</sup>	2 by 2 <sup>O</sup>	2 by 2 <sup>O</sup>	2 by 2 <sup>O</sup>	2 by 2 <sup>O</sup>
4 by 2 <sup>O</sup>	3 by 3 <sup>O</sup>	3 by 3 <sup>O</sup>	3 by 3 <sup>O</sup>	3 by 3 <sup>O</sup>	3 by 3 <sup>O</sup>
4 by 4 <sup>O</sup>	4 by 2 <sup>O</sup>	4 by 4 <sup>O</sup>	4 by 4 <sup>O</sup>	4 by 4 <sup>O</sup>	4 by 4 <sup>O</sup>
5 by 4 <sup>O</sup>	4 by 4 <sup>O</sup>	5 by 5 <sup>O</sup>			5 by 5 <sup>O</sup>
5 by 5 <sup>O</sup>	5 by 4 <sup>O</sup>	6 by 6 <sup>O</sup>			6 by 6 <sup>O</sup>
6 by 4 <sup>O</sup>	6 by 4 <sup>O</sup>				
6 by 6 <sup>O</sup>	6 by 6 <sup>O</sup>				
8 by 4 <sup>*</sup>	8 by 4 <sup>*</sup>				
8 by 6 <sup>*</sup>	8 by 6 <sup>*</sup>				
10 by 6 <sup>*</sup>	10 by 8 <sup>O</sup>				
	12 by 6 <sup>*</sup>				
	12 by 10 <sup>O</sup>				
	15 by 12 <sup>O</sup>				

<sup>A</sup> For details of hubs and spigots, see Table 1. For details of tapping bosses, see Table 42.

<sup>B</sup> \* indicates this item is made in extra heavy.

<sup>O</sup> indicates this item is made in service weight.

**ASTM A 74**

**TABLE 38 Dimensions of Screw Plugs (Brass) for 'XH' and 'SV'**

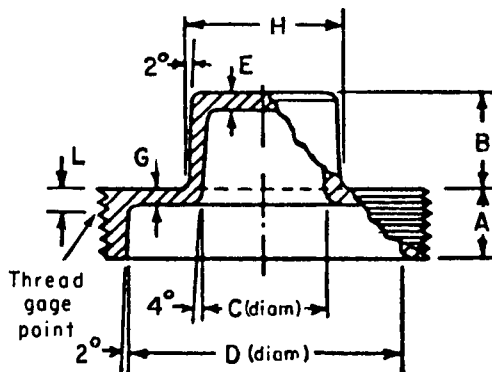

NOTE 1—1 in. = 25.4 mm.  
 NOTE 2—When thread gage is screwed tightly on plug by hand, large end of gage shall be the distance  $L \pm 1\frac{1}{2}$  turns from surface of plug.

Size, in.	Dimensions, in. <sup>A</sup>							
	A	B	C	D	E	G	Across flats H	L
1¼	½ [13]	½ [13]	¾ [19]	1½ [33]	⅝ [4]	⅛ [3]	1 [25]	⅝ [4]
1½	⅝ [16]	¾ [19]	¾ [19]	1½ [38]	⅜ [5]	⅛ [3]	1 [25]	⅜ [5]
2	⅝ [16]	¾ [19]	1 [25]	2 [51]	⅜ [5]	⅛ [3]	1¼ [32]	⅜ [5]
2½	¾ [19]	¾ [19]	1½ [24]	2¾ [60]	⅜ [5]	⅝ [4]	1¼ [32]	¼ [6]
3	¾ [19]	1 [25]	1½ [49]	2½ [75]	⅜ [5]	⅝ [4]	1½ [42]	¼ [6]
3½	¾ [19]	1 [25]	1¼ [32]	3⅜ [87]	¼ [6]	⅜ [5]	1½ [42]	¼ [6]
4	7⁄8 [22]	1 [25]	1½ [41]	3½ [100]	¼ [6]	⅜ [5]	2 [51]	⅜ [8]
5	1 [25]	1 [25]	1½ [49]	4½ [125]	⅝ [8]	7⁄32 [6]	2¾ [60]	⅜ [10]3
6	1 [25]	1 [25]	1¾ [48]	5½ [151]	⅝ [10]	¼ [6]	2¾ [60]	⅜ [10]

<sup>A</sup>Heads of plugs shall be either square or hexagonal. Dimension H is taken between opposite sides of either style used.

**TABLE 39 Dimensions of Blind Plugs**

NOTE 1—1 in. = 25.4 mm.

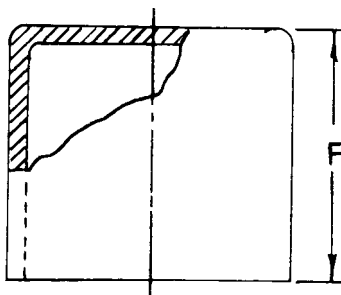

Size, in. <sup>A</sup> Availability <sup>B</sup>	F, in.
2°O	3½ [89]
3°O	3¾ [95]
4°O	4 [102]
5°O	4 [102]
6°O	4 [102]
8°O	4½ [114]
10°O	4½ [114]
12°O	5¼ [133]
15°O	5¼ [133]

<sup>A</sup> For dimensions of open end (spigot) and wall thickness, see Table 1.

<sup>B</sup> \* indicates this item is made in extra heavy.

O indicates this item is made in service weight.

**ASTM A 74**

**TABLE 40 Dimensions of Iron Body Ferrules With Screw Plugs**

NOTE 1—1 in. = 25.4 mm.

NOTE 2—Tappings for sizes 2 in. to 6 in., inclusive, allow entrance for testing plugs. See Table 38 for screw plugs.

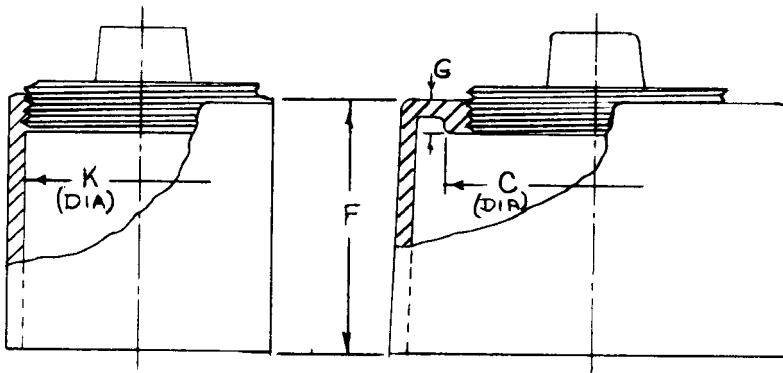

Size, in., Availability <sup>A</sup>	Dimensions, in. <sup>B</sup>					
	C	F	I.P.S. Tapping	Tapping Depth of G	K	R
2°O	...	3½ [89]	1½ [38]	½ [13]	2 [51]	1¼ [32]
3°O	...	3¾ [95]	2½ [64]	¼ [14]	3 [76]	1⅝ [35]
4°O	...	4¼ [108]	3½ [89]	⅝ [14]	4 [102]	1½ [38]
5°O	...	4¼ [108]	4 [102]	⅝ [16]	5 [127]	1½ [38]
6°O	...	4¼ [108]	5 [127]	⅝ [16]	6 [152]	1½ [38]
8°O	7⅝ [187]	4½ [114]	6 [152]	¾ [19]	8 [203]	1⅞ [48]
10°O	7½ [191]	4½ [114]	6 [152]	¾ [19]	10 [254]	1⅞ [48]
12°O	7½ [191]	5¼ [133]	6 [152]	¾ [19]	12 [305]	2⅜ [60]
15°O	7½ [191]	5¼ [133]	6 [152]	¾ [19]	15 [381]	2⅜ [60]

<sup>A</sup>\* indicates this item is made in extra heavy.

O indicates this item is made in service weight.

<sup>B</sup> For dimensions of open end (spigot) and wall thickness, see Table 1.

**ASTM A 74**

**TABLE 41 Dimensions of Closet Bends**

NOTE 1—1 in. = 25.4 mm.

NOTE 2—Laying lengths determined by the manufacturer standard interval for lengths is 2 in.

NOTE 3—Optional features are: Break off grooves, driving lugs, tapping bosses, plug inlets and screw joints.

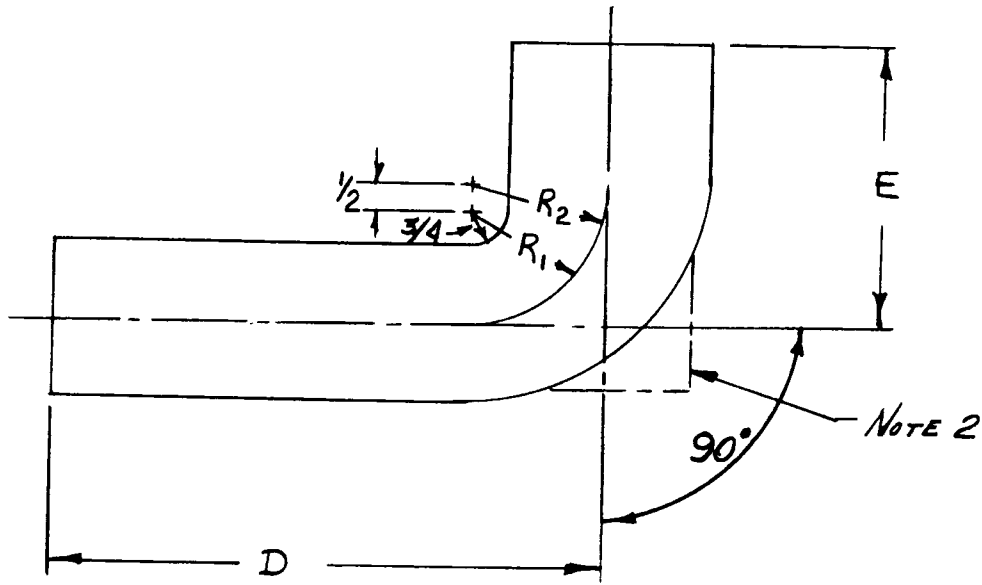

Size, in., Availability <sup>A</sup>	Dimensions in in. <sup>B,C</sup>			
	$D$	$E$	$R_1$	$R_2$
3 by 3°O	Various	Various	2½ [64]	
3 by 4°O	Various	Various		3 [76]
4 by 4°O	Various	Various	3 [76]	

<sup>A\*</sup> indicates this item is made in extra heavy.

O indicates this item is made in service weight.

<sup>B</sup> For details of spigot and barrel dimensions see Table 1.

<sup>C</sup> For details of tapping bosses, see Table 42.



**ASTM A 74**

**TABLE 42 Dimensions of Tapping Bosses for 'XH' and 'SV'**

NOTE 1— in. = 25.4 mm.

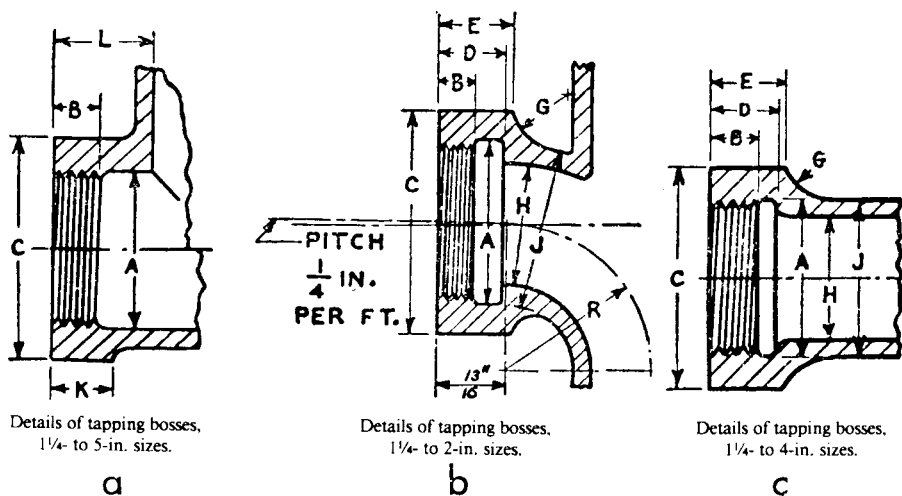

Size, in.	Dimensions, in.										
	A	B	C	D	E	G	H	J	K	L	R
1 1/4	1 15/16	7/16	2 11/16	3/4	7/8	1/2	1 1/2	1 7/8	...	1	1 3/4
1 1/2	1 15/16	7/16	2 11/16	3/4	7/8	1/2	1 1/2	1 7/8	3/4	1	1 3/4
2	2 7/16	7/16	3 1/4	3/4	1 5/16	5/8	2	2 3/8	...	1	2 1/4
2 1/2	2 15/16	3/4	3 7/8	...	...	...	...	...	1	...	...
3	3 9/16	3/4	4 5/8	1 3/16	1 5/16	1	3	3 1/2	1	...	...
3 1/2	4 1/16	3/4	5 1/8	...	...	...	...	...	1 1/8	...	...
4	4 9/16	13/16	5 3/4	1 1/4	1 7/16	1 1/8	4	4 1/2	1 1/8	...	...
5	5 5/8	1 5/16	7 1/16	...	...	...	...	...	1 3/8	...	...

**APPENDIXES**

**(Nonmandatory Information)**

**X1. DIMENSIONS FOR INFORMATION ONLY**

X1.1 The dimensions in Table X1.1 are given for use as convenient information on details of the hub barrel, and spigot, and are not requirements of this specification.



**TABLE X1.1 Outside Dimensions of Hub, Barrel, and Spigot for Detailing, in.**

NOTE 1—1 in. = 25.4 mm.

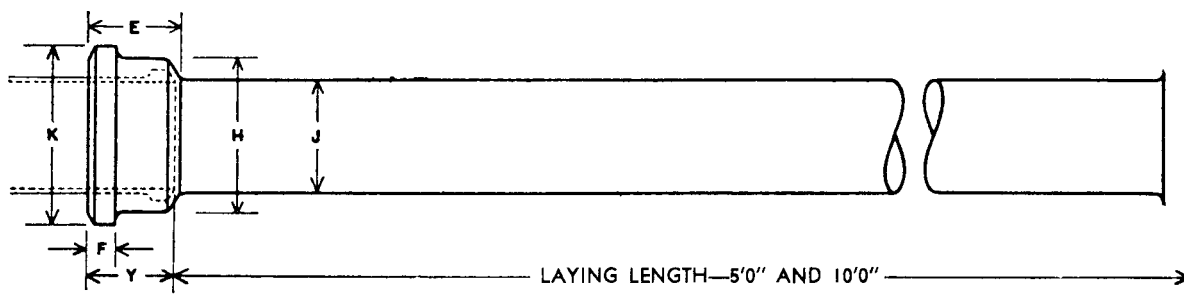

Size (nominal ID)	Extra-Heavy Pipe 'XH'					
	K max	H max	J	F	Y	E
2	4 <sup>1</sup> / <sub>16</sub> [105]	3 <sup>5</sup> / <sub>16</sub> [92]	2 <sup>3</sup> / <sub>16</sub> [60]	3/4 [19]	2 <sup>1</sup> / <sub>2</sub> [64]	2 <sup>3</sup> / <sub>4</sub> [70]
3	5 <sup>3</sup> / <sub>16</sub> [137]	4 <sup>15</sup> / <sub>16</sub> [125]	3 <sup>1</sup> / <sub>2</sub> [89]	1 <sup>3</sup> / <sub>16</sub> [21]	2 <sup>3</sup> / <sub>4</sub> [70]	3 <sup>1</sup> / <sub>4</sub> [83]
4	6 <sup>3</sup> / <sub>16</sub> [162]	5 <sup>15</sup> / <sub>16</sub> [151]	4 <sup>1</sup> / <sub>2</sub> [114]	7/8 [22]	3 [76]	3 <sup>1</sup> / <sub>2</sub> [89]
5	7 <sup>3</sup> / <sub>16</sub> [187]	6 <sup>15</sup> / <sub>16</sub> [176]	5 <sup>1</sup> / <sub>2</sub> [140]	7/8 [22]	3 [76]	3 <sup>1</sup> / <sub>2</sub> [89]
6	8 <sup>3</sup> / <sub>16</sub> [213]	7 <sup>15</sup> / <sub>16</sub> [202]	6 <sup>1</sup> / <sub>2</sub> [165]	7/8 [22]	3 [76]	3 <sup>1</sup> / <sub>2</sub> [89]
8	11 <sup>1</sup> / <sub>16</sub> [281]	10 <sup>7</sup> / <sub>16</sub> [265]	8 <sup>5</sup> / <sub>16</sub> [219]	1 <sup>3</sup> / <sub>16</sub> [30]	3 <sup>1</sup> / <sub>2</sub> [89]	4 <sup>1</sup> / <sub>8</sub> [105]
10	13 <sup>1</sup> / <sub>16</sub> [338]	12 <sup>11</sup> / <sub>16</sub> [322]	10 <sup>3</sup> / <sub>4</sub> [273]	1 <sup>3</sup> / <sub>16</sub> [30]	3 <sup>1</sup> / <sub>2</sub> [89]	4 <sup>1</sup> / <sub>8</sub> [105]
12	15 <sup>7</sup> / <sub>16</sub> [392]	14 <sup>1</sup> / <sub>4</sub> [376]	12 <sup>3</sup> / <sub>4</sub> [324]	1 <sup>7</sup> / <sub>16</sub> [37]	4 <sup>1</sup> / <sub>4</sub> [108]	5 [127]
15	18 <sup>3</sup> / <sub>16</sub> [478]	18 <sup>1</sup> / <sub>16</sub> [462]	15 <sup>5</sup> / <sub>8</sub> [403]	1 <sup>7</sup> / <sub>16</sub> [37]	4 <sup>1</sup> / <sub>4</sub> [108]	5 [127]

Size (nominal ID)	Service-Pipe 'SV'					
	K max	H max	J	F	Y	E
2	3 <sup>15</sup> / <sub>16</sub> [100]	3 <sup>3</sup> / <sub>8</sub> [86]	2 <sup>1</sup> / <sub>4</sub> [57]	3/4 [19]	2 <sup>1</sup> / <sub>2</sub> [64]	2 <sup>3</sup> / <sub>4</sub> [70]
3	5 [127]	4 <sup>1</sup> / <sub>2</sub> [114]	3 <sup>1</sup> / <sub>4</sub> [83]	1 <sup>3</sup> / <sub>16</sub> [21]	2 <sup>3</sup> / <sub>4</sub> [70]	3 <sup>1</sup> / <sub>4</sub> [83]
4	6 [152]	5 <sup>1</sup> / <sub>2</sub> [140]	4 <sup>1</sup> / <sub>4</sub> [108]	7/8 [22]	3 [76]	3 <sup>1</sup> / <sub>2</sub> [89]
5	7 [178]	6 <sup>1</sup> / <sub>2</sub> [165]	5 <sup>1</sup> / <sub>4</sub> [133]	7/8 [22]	3 [76]	3 <sup>1</sup> / <sub>2</sub> [89]
6	8 [203]	7 <sup>1</sup> / <sub>2</sub> [191]	6 <sup>1</sup> / <sub>4</sub> [159]	7/8 [22]	3 [76]	3 <sup>1</sup> / <sub>2</sub> [89]
8	10 <sup>1</sup> / <sub>2</sub> [267]	9 <sup>3</sup> / <sub>8</sub> [251]	8 <sup>3</sup> / <sub>8</sub> [213]	1 <sup>3</sup> / <sub>16</sub> [30]	3 <sup>1</sup> / <sub>2</sub> [89]	4 <sup>1</sup> / <sub>8</sub> [105]
10	12 <sup>1</sup> / <sub>4</sub> [325]	12 <sup>3</sup> / <sub>16</sub> [310]	10 <sup>1</sup> / <sub>2</sub> [267]	1 <sup>3</sup> / <sub>16</sub> [30]	3 <sup>1</sup> / <sub>2</sub> [89]	4 <sup>1</sup> / <sub>8</sub> [105]
12	14 <sup>1</sup> / <sub>8</sub> [379]	14 <sup>9</sup> / <sub>16</sub> [364]	12 <sup>1</sup> / <sub>2</sub> [318]	1 <sup>7</sup> / <sub>16</sub> [37]	4 <sup>1</sup> / <sub>4</sub> [108]	5 [127]
15	18 <sup>5</sup> / <sub>16</sub> [465]	17 <sup>5</sup> / <sub>8</sub> [448]	15 <sup>5</sup> / <sub>8</sub> [397]	1 <sup>7</sup> / <sub>16</sub> [37]	4 <sup>1</sup> / <sub>4</sub> [108]	5 [127]

**X2. PROCEDURES FOR SOIL SURVEY TESTS AND OBSERVATIONS AND THEIR INTERPRETATION TO DETERMINE WHETHER CAST IRON PIPE FOR WASTE WATER OR OTHER LIQUIDS REQUIRES POLYETHYLENE ENCASEMENT**

**X2.1 Scope**

X2.1.1 In the appraisal of soil and other conditions that affect the corrosion rate of cast iron pipe, a minimum number of factors must be considered. They are outlined in the following sections. A method of evaluating and interpreting each factor and a method of weighting each factor to determine whether polyethylene encasement should be used are subsequently described.

**X2.2 Earth Resistivity**

X2.2.1 There are three methods for determining earth resistivity: four-pin, single-probe, and soil-box. In the field, a four-pin determination should be made with pins spaced at approximate pipe depth. This method yields an average of resistivity from the surface to a depth equal to pin spacing. However, results are sometimes difficult to interpret where dry top soil is overlaid with wetter soils and where soil types vary with depth. The Wenner configuration is used in conjunction with a resistivity meter. For all-around use, a unit with a capacity of up to 10<sup>4</sup> ohms is suggested because of its

versatility in permitting both field and laboratory testing in most soils.

X2.2.2 Because of the aforementioned difficulty in interpretation, the same unit may be used with a single probe that yields resistivity at the point of the probe. A boring is made into the subsoil so that the probe may be pushed into the soil at the desired depth.

X2.2.3 Inasmuch as the soil may not be typically wet, a sample should be removed for resistivity determination, which may be accomplished with any one of several laboratory units that permits the introduction of water to saturation, thus simulating saturated field conditions. Each of these units is used in conjunction with a soil resistivity meter.

X2.2.4 Interpretation of resistivity results is extremely important. To base an opinion on a four-pin reading with dry top soil averaged with wetter subsoil would probably result in an inaccurate premise. Only by reading the resistivity in soil at pipe depth can an accurate interpretation be made. Also, every effort should be made to determine the local situation concerning ground-water table, presence of shallow ground water, and

 **A 74**

approximate percentage of time the soil is likely to be water saturated.

X2.2.5 With cast iron pipe, corrosion protection provided by products of corrosion is enhanced if there are dry periods during each year. Such periods seem to permit hardening or toughening of the corrosion scale or products, which then become impervious and serve as better insulators.

X2.2.6 In making field determinations of resistivity, temperature is important. The result obtained increases as temperature decreases. As the water in the soil approaches freezing, resistivity increases greatly, and, therefore, is not reliable. Field determinations under frozen soil conditions should be avoided. Reliable results under such conditions can be obtained only by collection of suitable subsoil samples for analysis under laboratory conditions at suitable temperature.

X2.2.7 *Interpretation of Resistivity*—Because of the wide variance in results obtained under the methods described, it is difficult specifically to interpret any single reading without knowing which method was used. It is proposed that interpretation be based on the lowest reading obtained with consideration being given to other conditions, such as normal moisture content of the soil in question. Because of the lack of exact correlation between experiences and resistivity, it is necessary to assign ranges of resistivity rather than specific numbers. In Table X2.1, points are assigned to various ranges of resistivity.

**TABLE X2.1 Soil-Test Evaluation<sup>A</sup>**

Soil Characteristics	Points
Resistivity, ohm-cm (based on single probe at pipe depth or water-saturated soil-box):	
<700	10
700–1000	8
1000–1200	5
1200–1500	2
1500–2000	1
>2000	0
pH:	
0–2	5
2–4	3
4–6.5	0
6.5–7.5	0 <sup>B</sup>
7.5–8.5	0
>8.5	3
Redox potential:	
> + 100 mV	0
+ 50 tp + 100 mV	3.5
0 to + 50 mV	4
Negative	5
Sulfides:	
Positive	3.5
Trace	2
Negative	0
Moisture:	
Poor drainage, continuously wet	2
Fair drainage, generally moist	1
Good drainage, generally dry	0

<sup>A</sup>Ten Points = corrosive to cast iron pipe; protection indicated.

<sup>B</sup>If sulfides are present and low or negative redox potential results are obtained, three points shall be given for this range.

These points, when considered along with points assigned to other soil characteristics, are meaningful.

### X2.3 pH

X2.3.1 In the pH range from 0.0 to 4.0, the soil serves well as an electrolyte, and total acidity is important. In the pH range

from 6.5 to 7.5, soil conditions are optimum for sulfate reduction. In the pH range from 8.5 to 14.0, soils are generally quite high in dissolved salts, yielding a low soil resistivity.

X2.3.2 In testing pH, glass and reference electrodes are pushed into the soil sample and a direct reading is made following suitable temperature setting on the instrument. Normal procedures are followed for standardization.

### X2.4 Oxidation-Reduction (Redox) Potential

X2.4.1 The oxidation-reduction (redox) potential of a soil is significant because the most common sulfate-reducing bacteria can live only under anaerobic conditions. A redox potential greater than +100 mV shows the soil to be sufficiently aerated so that it will not support sulfate reducers. Potentials of zero to +100 mV may or may not indicate anaerobic conditions under which sulfate reducers thrive. This test also is accomplished using a portable pH meter, with platinum and reference electrodes inserted into the soil sample, which permits a reading of potential between the two electrodes. It should be noted that soil samples removed from a boring or excavation can undergo a change in redox potential on exposure to air. Such samples should be tested immediately on removal from the excavation. Experience has shown that heavy clays, muck, and organic soils are often anaerobic, and these soils should be regarded as potentially corrosive.

### X2.5 Sulfides

X2.5.1 The sulfide determination is recommended because of its field expediency. A positive sulfide reaction reveals a potential problem due to sulfate-reducing bacteria. The sodium azide-iodine qualitative test is used. In this determination, a solution of 3 % sodium azide in a 0.1 N iodine solution is introduced into a test tube containing a sample of the soil in question. Sulfides catalyze the reaction between sodium azide and iodine, with the resulting evolution of nitrogen. If strong bubbling or foaming results, sulfides are present, and the presence of sulfate-reducing bacteria is indicated. If very slight bubbling is noted, sulfides are probably present in small concentration and the result is noted as a trace.

### X2.6 Moisture Content

X2.6.1 Since prevailing moisture content is extremely important to all soil corrosion, every effort must be made to determine this condition. It is not proposed, however, to determine specific moisture content of a soil sample, because of the probability that content varies throughout the year, but to question local authorities who are able to observe the conditions many times during the year. (Although mentioned in X2.2, this variability factor is being reiterated to emphasize the importance of notation.)

### X2.7 Soil Description

X2.7.1 In each investigation, soil types should be completely described. The description should include color and physical characteristics, such as particle size, plasticity, friability, and uniformity. Observation and testing will reveal whether the soil is high in organic content; this should be noted. Experience has shown that in a given area, corrosivity may often be reflected in certain types and colors of soil. This

information is valuable for future investigations or for determining the most likely soils to suspect. Soil uniformity is important because of the possible development of local corrosion cells due to the difference in potential between unlike soil types, both of which are in contact with the pipe. The same is true for uniformity of aeration. If one segment of soil contains more oxygen than a neighboring segment, a corrosion cell can develop from the difference in potential. This cell is known as a differential aeration cell.

X2.7.2 There are several basic types of soil that should be noted: sand, loam, silt, clay, muck. Unusual soils, such as peat or soils high in foreign material, should also be noted and described.

### X2.8 Potential Stray Direct Current

X2.8.1 Any soil survey should include consideration of possible stray direct current with which the cast iron pipe installation might interfere. The widespread use of rectifiers and ground beds for cathodic protection of underground structures has resulted in a considerable threat from this source. Proximity of such cathodic protection systems should be noted. Among other potential sources of stray direct current are electric railways, industrial equipment, including welding and mine transportation equipment.

### X2.9 Experience With Existing Installations

X2.9.1 The best information on corrosivity of soil with respect to cast iron pipe is the result of experience with these

materials in the area in question. Every effort should be made to acquire such data by questioning local officials and, if possible, by actual observation of existing installations.

### X2.10 Soil-Test Evaluation

X2.10.1 Using the soil-test procedures described herein, the following tests are considered in evaluating corrosivity of the soil: resistivity, pH, redox potential, sulfides, and moisture. For each of these tests, results are categorized according to their contribution to corrosivity. Points are assigned based on experience with gray and ductile cast iron pipe. When results of these five test observations are available, the assigned points are totaled. If the sum is equal to ten or more, the soil is corrosive to cast iron pipe, and protection against exterior corrosion should be provided. This system is limited to soil corrosion and does not include consideration of stray direct current. Table X2.1 lists points assigned to the various test results.

### X2.11 General

X2.11.1 These notes deal only with cast iron pipe, the soil environment in which they will serve, and methods of determining the need for polyethylene encasement. When it is determined that a soil environment is corrosive to cast iron, Appendix X3 should be used.

## X3. POLYETHYLENE ENCASUREMENT FOR CAST IRON PIPE FOR WASTE WATER

### X3.1 Scope

X3.1.1 This practice covers materials and installation procedures for polyethylene encasement to be applied to underground installations of cast iron pipe. It is also used for polyethylene encasement of fittings, and other appurtenances to cast iron pipe systems.

X3.1.2 *This standard does not purport to address all of the safety concerns, if any, associated with its use. It is the responsibility of the user of this standard to establish appropriate safety and health practices and determine the applicability of regulatory limitations prior to use.*

### X3.2 Referenced Documents

X3.2.1 *ASTM Standard:*  
D 1248 Specification for Polyethylene Plastics Molding and Extrusion Materials<sup>8</sup>

### X3.3 Terminology

X3.3.1 *Definitions:*  
X3.3.1.1 *polyethylene encasement*—polyethylene material, in tube or sheet form, that is used to encase cast iron pipe.  
X3.3.1.2 *securing overlap*—any one of various methods of holding polyethylene encasement in place at the point of

overlap until backfilling operations are completed, such as with adhesive tape, plastic string, or tie straps or other suitable material.

### X3.4 Requirements

X3.4.1 *Materials:*  
X3.4.1.1 *Low-Density Polyethylene Film*—Low-density polyethylene film shall be manufactured of virgin polyethylene material conforming to the requirements of Specification D 1248 as shown in Table X3.1.

**TABLE X3.1 Polyethylene Characteristics**

Raw Material Used to Manufacture Polyethylene Encasement Material	
Type, class, grade, other characteristics in accordance with the latest revision of Specification D 1248	
Type	I
Class	A-natural color or C-black
Grade	E1
Flow rate, g/10 min	0.4 max
Dielectric strength, volume resistivity	10 <sup>15</sup> ·cm <sup>3</sup> , min
High-Density Cross-Laminated Polyethylene Encasement Material	
Tensile strength	1200 psi (8 MPa), min
Elongation	300 %, min
Dielectric strength	800 V/mil (31.5 V/μm) thickness, min

(a) *Thickness*—Low-density polyethylene film shall have a minimum nominal thickness of 0.008 in. (0.20 mm). The minus

<sup>8</sup> Annual Book of ASTM Standards, Vol 08.01.

tolerance on thickness shall not exceed 10 % of the nominal thickness.

**X3.4.1.2 High-Density Cross-Laminated Polyethylene Film**

High-density cross-laminated polyethylene film shall be manufactured of virgin polyethylene material conforming to the requirements of Specification D 1248 as shown in Table X3.2.

(a) *Thickness*—High-density cross-laminated polyethylene film shall have a minimum nominal thickness of 0.004 in. (0.10 mm). The minus tolerance on thickness shall not exceed 10 % of the nominal thickness.

**X3.4.2 Tube Size**—The tube size for each pipe diameter shall be as listed in Table X3.2.

**X3.5 Installation**

**X3.5.1 General:**

**X3.5.1.1** The polyethylene encasement shall prevent contact between the pipe and the surrounding backfill and bedding material, but is not intended to be a completely airtight or watertight enclosure. All lumps of clay, mud, cinders, etc. that are on the pipe surface shall be removed prior to installation of the polyethylene encasement. During installation, care shall be exercised to prevent soil or embedment material from becoming entrapped between the pipe and the polyethylene.

**X3.5.1.2** The polyethylene film shall be fitted to the contour of the pipe to effect a snug, but not tight, encasement with minimum space between the polyethylene and the pipe. Sufficient slack shall be provided in contouring to prevent stretching the polyethylene, bridging irregular surfaces such as hub-spigot interfaces, coupled joints, or fittings, and to prevent damage to the polyethylene due to backfilling operations. Overlaps and ends shall be secured by the use of adhesive tape, plastic string, plastic tie straps, or any other material capable of holding the polyethylene encasement in place until backfilling operations are completed.

**X3.5.1.3** For installations below the water table or in areas subject to tidal actions, or both, it is recommended that tube-form polyethylene be used with both ends sealed as thoroughly as possible with adhesive tape or plastic tie straps at the joint overlap. It is also recommended that circumferential wraps of tape or plastic tie straps be placed at 2-ft (0.6-m) intervals along the barrel of the pipe to help minimize the space between the polyethylene and the pipe.

**X3.5.2 Pipe**—This appendix includes three different methods for the installation of polyethylene encasement. Methods A and B are for use with polyethylene tubes and Method C is for use with polyethylene sheets.

**X3.5.2.1 Method A** (see Fig. X3.1):

(a) Cut the polyethylene tube to a length approximately 2 ft (0.6 m) longer than the length of the pipe section. Slip the tube around the pipe, centering it to provide a 1-ft (0.3-m) overlap on each adjacent pipe section, and bunching it accordion fashion lengthwise until it clears the pipe ends.

(b) Lower the pipe into the trench and make up the pipe joint with the preceding section of pipe. A shallow bell hole must be made at joints to facilitate installation of the polyethylene tube.

(c) After assembling the pipe joint, make the overlap of the polyethylene tube. Pull the bunched polyethylene from the preceding length of pipe, slip it over the end of the new length of pipe, and secure in place. Then slip the end of the polyethylene from the new pipe section over the end of the first wrap until it overlaps the joint at the end of the preceding length of pipe. Secure the overlap in place. Take up the slack width at the top of the pipe as shown in Fig. X3.2, to make a snug, but not tight, fit along the barrel of the pipe, securing the fold at quarter points.

(d) Repair any rips, punctures, or other damage to the polyethylene with adhesive tape or with a short length of polyethylene tube cut open, wrapped around the pipe, and secured in place. Confirm and adjust any necessary grade on the piping section. Proceed with installations of the next section of pipe in the same manner.

**X3.5.2.2** Cut the polyethylene tube to a length approximately 1 ft (0.3 m) shorter than the length of the pipe section. Slip the tube around the pipe, centering it to provide 6 in. (150 mm) of bare pipe at each end. Make the polyethylene snug, but not tight, as shown in Fig. X3.2; secure ends as described in X3.5.2.1.

(a) Before making up a joint, slip a 3-ft (0.9-m) length of polyethylene tube over the end of the preceding pipe section, bunching it accordion fashion lengthwise. After completing the joint, pull the 3-ft length of polyethylene previously installed on each adjacent section of pipe by at least 1 ft (0.3 m); make snug and secure each end as described in X3.5.2.1.

(b) Repair any rips, punctures, or other damage to the polyethylene as described in X3.5.2.1. Reaffirm grade on the piping, as required. Proceed with installation of the next section of pipe in the same manner.

**X3.5.2.3** Flat sheet polyethylene shall have a minimum width twice the flat tube width shown in Table X3.3.

(a) Cut the polyethylene sheet to a length approximately 2 ft (0.6 m) longer than the length of pipe section. Center the cut length to provide a 1-ft (0.3-m) overlap on each adjacent pipe section, bunching it until it clears the pipe ends. Wrap the polyethylene around the pipe so that it overlaps circumferentially over the top quadrant of the pipe. Secure the cut edge of polyethylene sheet at approximately 3-ft (0.9-m) intervals along the pipe length.

(b) Lower the wrapped pipe into the trench and make up the pipe joint with the preceding section of pipe. A shallow hub hole must be made at joints to facilitate installation of the polyethylene. After completing the joint, make the overlap as described in X3.5.2.1.

(c) Repair any rips, punctures, or other damage to the

**TABLE X3.2 Polyethylene Tube Sizes**

Nominal Pipe Diameter, in.	Recommended Polyethylene Flat Tube Width, in. (cm) <sup>A</sup>
1½, 2, 3	14 (35)
4	16 (41)
6	20 (51)
8	24 (61)
10	27 (69)
12	30 (76)
14	34 (86)
15	37 (94)

<sup>A</sup>For flat sheet polyethylene, see X3.5.2.3.



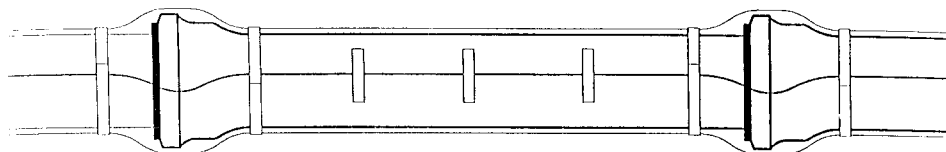

**FIG. X3.1 Method A Hub Pipe**

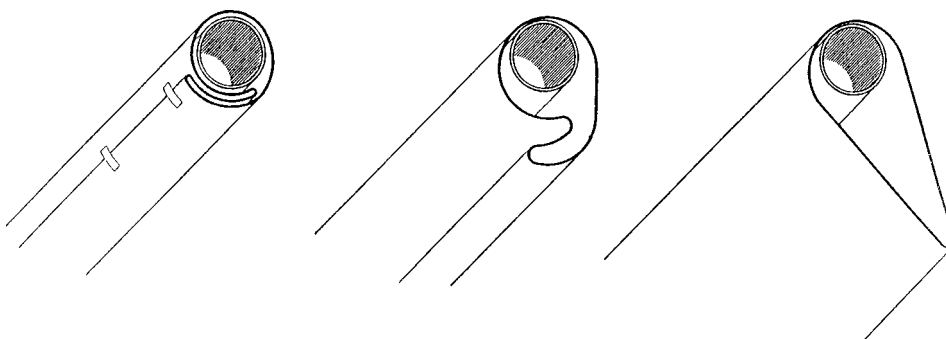

**FIG. X3.2 Method A Slack Reduction Procedure**

**TABLE X3.3 High-Density Cross-Laminated Polyethylene Characteristics**

Raw Material Used to Manufacture Polyethylene Encasement Material	
Type, class, grade, other characteristics in accordance with the latest revision of Specification D 1248	
Type	111
Class	A-natural color, B-colors, or C-black
Grade	P33
Flow rate, g/10 min	0.4 to 0.5 g/10, min
Dielectric strength, volume resistivity	$10^{15}$ ohm-cm, min
High-Density Cross-Laminated Polyethylene Encasement Material	
Tensile strength	5000 psi (34.6 MPa), min
Elongation	100 %, min
Dielectric strength	800 V/mil (31.5 V/ $\mu$ m) thickness, min

polyethylene as described in X3.5.2.1. Confirm and adjust any necessary grade of the piping section. Proceed with installation of the next section of pipe in the same manner.

**X3.5.3 Pipe-Shaped Appurtenances**—Bends, reducers, off-sets, and other pipe-shaped appurtenances shall be covered with polyethylene in the same manner as the pipe.

**X3.5.4 Odd-Shaped Appurtenances**—Wrap tees, crosses, and other odd-shaped pieces that cannot practically be wrapped in a tube, with a flat sheet or split length of polyethylene tube. Pass the sheet under the appurtenance and bring up around the body. Make seams by bringing the edges together, folding over twice, and taping down (see Fig. X3.3). Handle slack width and overlaps at joints as described in X3.5.2.1. Tape polyethylene securely in place.

**X3.5.5 Repairs**—Repair any cuts, tears, punctures, or damage to polyethylene with adhesive tape or with a short length of polyethylene tube cut open, wrapped around the pipe covering the damaged area, and secured in place.

**X3.5.6 Junctions Between Wrapped and Unwrapped Pipe**—

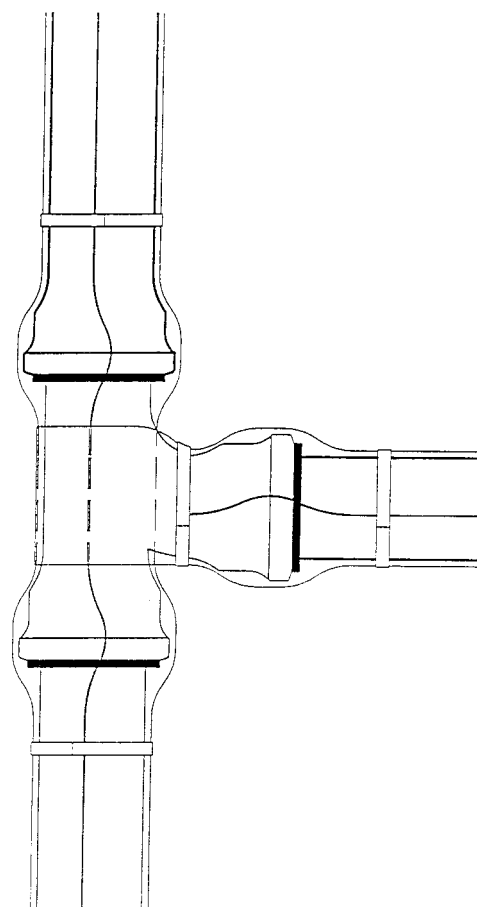

**FIG. X3.3 Method A Installation on Odd-Shaped Appurtenances, Hub Pipe, and Fittings**

Where polyethylene wrapped pipe joins a pipe that is not wrapped, extend the polyethylene tube to cover the unwrapped pipe a distance of at least 3 ft (0.9 m). Secure the end with circumferential turns of tape.

 **A 74**

X3.5.7 *Backfill for Polyethylene Wrapped Pipe*—Backfill material shall be the same as specified for pipe without polyethylene wrapping. Take special care to prevent damage to the polyethylene wrapping when placing backfill. Backfill

material shall be free of cinders, refuse, frozen earth, boulders, rocks, stones, job site debris, or other material that could damage polyethylene.

*The American Society for Testing and Materials takes no position respecting the validity of any patent rights asserted in connection with any item mentioned in this standard. Users of this standard are expressly advised that determination of the validity of any such patent rights, and the risk of infringement of such rights, are entirely their own responsibility.*

*This standard is subject to revision at any time by the responsible technical committee and must be reviewed every five years and if not revised, either reapproved or withdrawn. Your comments are invited either for revision of this standard or for additional standards and should be addressed to ASTM Headquarters. Your comments will receive careful consideration at a meeting of the responsible technical committee, which you may attend. If you feel that your comments have not received a fair hearing you should make your views known to the ASTM Committee on Standards, at the address shown below.*

*This standard is copyrighted by ASTM, 100 Barr Harbor Drive, PO Box C700, West Conshohocken, PA 19428-2959, United States. Individual reprints (single or multiple copies) of this standard may be obtained by contacting ASTM at the above address or at 610-832-9585 (phone), 610-832-9555 (fax), or [service@astm.org](mailto:service@astm.org) (e-mail); or through the ASTM website ([www.astm.org](http://www.astm.org)).*