



Designation: A 746 – 99

Standard Specification for Ductile Iron Gravity Sewer Pipe¹

This standard is issued under the fixed designation A 746; the number immediately following the designation indicates the year of original adoption or, in the case of revision, the year of last revision. A number in parentheses indicates the year of last reapproval. A superscript epsilon (ϵ) indicates an editorial change since the last revision or reapproval.

This standard has been approved for use by agencies of the Department of Defense.

1. Scope

1.1 This specification covers 4 to 64-in. ductile iron gravity sewer pipe centrifugally cast with push-on joints. This specification may be used for pipe with other types of joints, as may be agreed upon at the time of purchase.

1.2 This specification covers trench load design procedures for both cement-lined pipe and flexible-lined pipe. Maximum depth of cover tables are included for both types of linings.

1.3 The values stated in inch-pound units are to be regarded as the standard. The values given in parentheses are for information only.

2. Referenced Documents

2.1 ASTM Standards:

E 8 Test Methods for Tension Testing of Metallic Materials²

E 23 Test Methods for Notched Bar Impact Testing of Metallic Materials²

2.2 ANSI/AWWA Standards:

C104/A21.4 Cement Mortar Lining for Ductile-Iron Pipe and Fittings for Water³

C111/A21.11 Rubber-Gasket Joints for Ductile-Iron Pressure Pipe and Fittings³

C150/A21.50 Thickness Design of Ductile-Iron Pipe³

C600 Installation of Ductile-Iron Water Mains and Their Appurtenances

2.3 ASCE Standards:

Manuals and Reports on Engineering Practice, No. 37, (WCPF Manual of Practice No. 9). "Design and Construction of Sanitary and Storm Sewers"⁴

2.4 AASHTO Standard:

AASHTO T-99 Standard Method of Test for the Moisture-Density Relations of Soils Using a 5.5 lb (2.5 kg) Rammer and a 12 in. (305 mm) Drop

3. Terminology

3.1 Symbols: Symbols:

3.1.1 A —outside radius of pipe,

$$ft = \frac{D}{24}$$

$$\left(\text{in metres} = \frac{D}{2000} \right)$$

3.1.2 a —conversion factor, lb/ft² to psi = 144 (kN/m² to kPa = 1)

3.1.3 B —1.5 ft (0.457 m)

3.1.4 b —Effective pipe length: 36 in. (0.914 m)

3.1.5 C —surface load factor, Table 1

3.1.6 D —outside diameter, in., Table 2

3.1.7 E —modulus of elasticity, 24×10^6 psi (165.5×10^6 kPa)

3.1.8 E' —modulus of soil reaction, psi, Table 3

3.1.9 F —impact factor, 1.5

3.1.10 f —design bending stress, 48 000 psi (331×10^3 kPa)

3.1.11 H —depth of cover, ft (m)

3.1.12 K_b —bending moment coefficient, Table 3

3.1.13 K_x —deflection coefficient, Table 3

3.1.14 P —wheel load, 16 000 lb (7257 kg)

3.1.15 P_e —earth load, psi (kPa)

3.1.16 P_t —truck load, psi (kPa)

3.1.17 P_v —trench load, psi (kPa) = $P_e + P_t$

3.1.18 R —reduction factor which takes into account the fact that the part of the pipe directly below the wheels is aided in carrying the truck load by adjacent parts of the pipe that receive little or no load from the wheels, Table 4

3.1.19 t —net thickness, in. (mm)

3.1.20 t_1 —minimum manufacturing thickness, in., $t + 0.08$, (in mm, $t + 2.0$)

3.1.21 w —soil weight, 120 lb/ft³ (18.85 kN/m³)

3.1.22 ΔX —design deflection, in. (mm),

$$[\Delta X = 0.03 D], \text{ or } [(\Delta X = 0.05 D) \text{ for flexible linings}]$$

4. General Requirements

4.1 The pipe shall be ductile iron in accordance with Section 9.

¹ This specification is under the jurisdiction of ASTM Committee A-4 on Iron Castings and is the direct responsibility of Subcommittee A04.12 on Pipes and Tubes.

Current edition approved Oct. 10, 1999. Published November 1999. Originally published as A 746 – 77. Last previous edition A 746 – 95.

² Annual Book of ASTM Standards, Vol 03.01.

³ Available from American National Standards Institute, 11 West 42nd Street, 13th Floor, New York, NY 10036.

⁴ Available from the American Society of Civil Engineers, 345 East 47th St., New York, NY 10017.



TABLE 1 Surface Load Factors for Single Truck on Unpaved Road

Depth of Cover ft	Pipe Size—in.								
	3	4	6	8	10	12	14	16	18
	Surface Load Factor—C								
2.5	0.0589	0.0713	0.1020	0.1328	0.1615	0.1901	0.2178	0.2443	0.2698
3	0.0437	0.0530	0.0759	0.0990	0.1207	0.1424	0.1637	0.1843	0.2044
4	0.0265	0.0321	0.0460	0.0602	0.0736	0.0871	0.1005	0.1136	0.1265
5	0.0176	0.0213	0.0306	0.0401	0.0490	0.0581	0.0672	0.0761	0.0849
6	0.0125	0.0151	0.0217	0.0284	0.0348	0.0413	0.0478	0.0542	0.0606
7	0.0093	0.0113	0.0162	0.0212	0.0260	0.0308	0.0357	0.0405	0.0453
8	0.0072	0.0087	0.0125	0.0164	0.0201	0.0238	0.0276	0.0313	0.0350
9	0.0057	0.0069	0.0099	0.0130	0.0160	0.0190	0.0219	0.0249	0.0279
10	0.0046	0.0056	0.0081	0.0106	0.0130	0.0154	0.0179	0.0203	0.0227
12	0.0032	0.0039	0.0056	0.0074	0.0091	0.0108	0.0125	0.0142	0.0159
14	0.0024	0.0029	0.0042	0.0055	0.0067	0.0080	0.0092	0.0105	0.0117
16	0.0018	0.0022	0.0032	0.0042	0.0051	0.0061	0.0071	0.0080	0.0090
20	0.0012	0.0014	0.0020	0.0027	0.0033	0.0039	0.0045	0.0052	0.0058
24	0.0008	0.0010	0.0014	0.0019	0.0023	0.0027	0.0032	0.0036	0.0040
28	0.0006	0.0007	0.0010	0.0014	0.0017	0.0020	0.0023	0.0026	0.0030
32	0.0005	0.0006	0.0008	0.0011	0.0013	0.0015	0.0018	0.0020	0.0023

Depth of Cover ft	Pipe Size—in.								
	20	24	30	36	42	48	54	60	64
	Surface Load Factor—C								
2.5	0.2941	0.3390	0.3962	0.4437	0.4813	0.5115	0.5366	0.5488	0.5592
3	0.2237	0.2602	0.3085	0.3507	0.3857	0.4153	0.4412	0.4543	0.4657
4	0.1391	0.1635	0.1972	0.2284	0.2559	0.2808	0.3040	0.3164	0.3277
5	0.0936	0.1106	0.1347	0.1576	0.1786	0.1982	0.2173	0.2278	0.2377
6	0.0669	0.0793	0.0970	0.1143	0.1304	0.1458	0.1612	0.1698	0.1781
7	0.0500	0.0594	0.0730	0.0863	0.0988	0.1111	0.1235	0.1306	0.1374
8	0.0387	0.0461	0.0567	0.0672	0.0773	0.0871	0.0973	0.1031	0.1088
9	0.0309	0.0367	0.0453	0.0538	0.0620	0.0700	0.0784	0.0833	0.0880
10	0.0251	0.0299	0.0370	0.0440	0.0507	0.0574	0.0644	0.0685	0.0725
12	0.0176	0.0210	0.0259	0.0309	0.0357	0.0405	0.0456	0.0486	0.0515
14	0.0130	0.0155	0.0192	0.0229	0.0265	0.0301	0.0339	0.0362	0.0384
16	0.0100	0.0119	0.0147	0.0176	0.0204	0.0232	0.0262	0.0279	0.0297
20	0.0064	0.0076	0.0095	0.0113	0.0131	0.0149	0.0169	0.0181	0.0192
24	0.0045	0.0053	0.0066	0.0079	0.0091	0.0104	0.0118	0.0126	0.0134
28	0.0033	0.0039	0.0049	0.0058	0.0067	0.0077	0.0087	0.0093	0.0099
32	0.0025	0.0030	0.0037	0.0044	0.0052	0.0059	0.0067	0.0071	0.0076

4.2 Push-on joints shall comply with all applicable requirements of ANSI/AWWA C 111/A21.11.

Pipe with other types of joints shall comply with the joint dimensions and weights agreed upon at the time of purchase, but in all other respects shall fulfill the requirements of this specification.

4.3 Unless otherwise specified, pipe shall have a nominal length of 18 or 20 ft (5.5 or 6.1 m). A maximum of 20 % of the total number of pipe of each size specified in an order may be furnished as much as 24 in. (610 mm) shorter than the nominal laying length, and an additional 10 % may be furnished as much as 6 in. (152 mm) shorter than the nominal laying length.

5. Tolerances or Permitted Variations

5.1 *Dimensions*—The spigot end, bell, and socket of the pipe and the accessories shall be gaged with suitable gages at sufficiently frequent intervals to assure that the dimensions comply with the requirements of this specification. The smallest inside diameter (ID) of the sockets and the outside diameter (OD) of the spigot ends shall be tested with circular gauges. Other socket dimensions shall be gauged as may be appropriate.

5.2 *Thickness*—Minus thickness tolerances of pipe shall not exceed those shown in Table 5.

NOTE 1—An additional minus tolerance of 0.02 in. (0.5 mm) shall be permitted along the barrel of the pipe for a distance not to exceed 12 in. (305 mm).

5.3 *Weight*—The weight of any single pipe shall not be less than the tabulated weight by more than 6 % for pipe 12 in. or smaller in diameter, or by more than 5 % for pipe larger than 12 in. in diameter.

6. Coating and Lining

6.1 *Outside Coating*—The outside coating for use under normal conditions shall be an asphaltic coating approximately 1 mil (0.025 mm) thick. The coating shall be applied to the outside of all pipe, unless otherwise specified. The finished coating shall be continuous and smooth, neither brittle when cold, nor sticky when exposed to the sun, and shall be strongly adherent to the pipe.

6.2 *Cement-Mortar Linings*—Unless otherwise specified, the lining shall be cement-mortar in accordance with ANSI/AWWA C 104/A21.4.

TABLE 2 Nominal Thicknesses for Standard Pressure Classes of Ductile-Iron Pipe

Size, in.	Outside Diameter, in. (mm)	Pressure Class				
		150	200	250	300	350
Nominal Thickness, in. (mm)						
3	3.96 (100.6)	0.25 ^A (6.4)
4	4.80 (121.9)	0.25 ^A (6.4)
6	6.90 (175.3)	0.25 ^A (6.4)
8	9.05 (229.9)	0.25 ^A (6.4)
10	11.10 (281.9)	0.26 (6.6)
12	13.20 (335.3)	0.28 (7.1)
14	15.30 (388.6)	0.28 (7.1)	0.30 (7.6)	0.31 (7.9)
16	17.40 (442.0)	0.30 (7.6)	0.32 (8.1)	0.34 (8.6)
18	19.50 (495.3)	0.31 (7.9)	0.34 (8.6)	0.36 (9.1)
20	21.60 (548.6)	0.33 (8.4)	0.36 (9.1)	0.38 (9.7)
24	25.80 (655.3)	...	0.33 (8.4)	0.37 (9.4)	0.40 (10.2)	0.43 (10.9)
30	32.00 (812.8)	0.34 (8.6)	0.38 (9.7)	0.42 (10.7)	0.45 (11.4)	0.49 (12.4)
36	38.30 (972.8)	0.38 (9.7)	0.42 (10.7)	0.47 (11.9)	0.51 (12.9)	0.56 (14.2)
42	44.50 (1130.3)	0.41 (10.4)	0.47 (11.9)	0.52 (13.2)	0.57 (14.5)	0.63 (16.0)
48	50.80 (1290.3)	0.46 (11.7)	0.52 (13.2)	0.58 (14.7)	0.64 (16.3)	0.70 (17.8)
54	57.56 (1450.3)	0.51 (12.9)	0.58 (14.7)	0.65 (16.5)	0.72 (18.3)	0.79 (20.1)
60	61.61 (1564.9)	0.54 (13.7)	0.61 (15.5)	0.68 (17.3)	0.76 (19.3)	0.83 (21.1)
64	65.67 (1668.0)	0.56 (14.2)	0.64 (16.3)	0.72 (18.3)	0.80 (20.3)	0.87 (22.1)

^A Calculated thicknesses for these sizes and pressure ratings are less than those shown above. Presently these are the lowest nominal thicknesses available in these sizes.

6.3 *Special Linings*—For severely aggressive wastes, other types of linings may be available. Such special linings shall be specified in the invitation for bids and on the purchase order.

7. Pipe Design

7.1 This section covers the design of ductile iron pipe for trench loads.

7.2 *Determining the Total Calculated Thickness and Standard Thickness:*

7.2.1 Determine the trench load, P_v . Table 6 gives the trench load, including the earth load, P_e , plus the truck load, P_t , for 2.5 to 32 ft (0.76 to 9.75 m) of cover.

7.2.2 Determine the standard laying condition from the descriptions in Table 3 and select the appropriate table for diameter-thickness ratios from Tables 7-11. Each table lists diameter-thickness ratios calculated for both bending and deflection over a range of trench loads.

7.2.3 For bending-stress design, enter the column headed “Bending-Stress Design” in the appropriate table of Tables 7-11, and locate the tabulated trench load P_v nearest to the calculated P_v nearest to the calculated P_v from Sec. 7.2.1. (If the calculated P_v is halfway between two tabulated values, use the larger P_v value.) Select the corresponding D/t value for this P_v . Divide the pipe’s outside diameter D (Table 2) by the D/t value to obtain net thickness t .

7.2.4 For deflection design, enter the column headed “Deflection Design” in the appropriate table of Tables 7-11, and locate the tabulated trench load P_v nearest to the calculated P_v from Sec. 7.2.1. (If the calculated P_v is less than the minimum P_v listed in the table, design for trench load is not controlled by deflection and this determination need not be completed.) If the calculated P_v is halfway between two tabulated values, use the larger P_v value. Select the corresponding D/t_1 value for this P_v . Divide the pipe’s outside diameter (Table 2) by the D/t_1 value to obtain minimum manufacturing thickness t_1 . Deduct 0.08 in. (2.0 mm) service allowance to obtain the thickness t .

NOTE 2—Service allowance equals 0.08 in. (2.0 mm) for all sizes of ductile-iron pipe.

7.2.5 Compare the net thicknesses from 7.2.3 and 7.2.4 and select the larger of the two. This will be the net thickness, t .

7.2.6 Add the service allowance of 0.08 in. (2.0 mm) to the net thickness, t . The resulting thickness is the minimum manufacturing thickness, t_1 .

7.2.7 Add the casting tolerance from Table 5 to the minimum manufacturing thickness, t_1 . The resulting thickness is the total calculated thickness.

7.2.8 In specifying and ordering pipe, use the total calculated thickness from Sec. 7.2.7 to select a standard pressure-class thicknesses from Table 2. When the calculated thickness is between two nominal thicknesses, select the larger of the two. When specifying and ordering pipe, use the pressure-class listed in Table 2 for this nominal thickness.

NOTE 3—On specific projects, manufacturers may be willing to furnish pipe with thicknesses that fall between standard classes.

7.2.9 The appropriate standard pressure class may also be determined by using the Design Equations in Sec. 7.4.

7.3 *Design Example*—Calculate the thickness for 30-in. cement-lined ductile iron pipe bedded in loose soil for a minimum depth of 4 in. (100 mm), backfill lightly consolidated to the top of pipe, Laying Condition Type 3, under 10 ft (3 m) of cover.

Earth load, Table 6, P_e	= 8.3 psi
Truck load, Table 6, P_t	= 0.7 psi
Trench load, $P_v = P_e + P_t$	= 9.0 psi

7.3.1 Entering P_v of 9.0 psi in Table 9, the bending stress design requires D/t of 163.

Net thickness, t , for bending stress = $D/(D/t) = 32.00/163 = 0.20$

7.3.2 Reentering P_v of 9.0 psi in Table 9, the deflection design requires D/t_1 of 136.

ASTM A 746 – 99

TABLE 3 Design Values for Standard Laying Conditions ^A

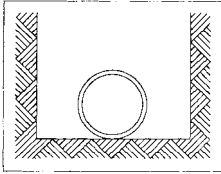
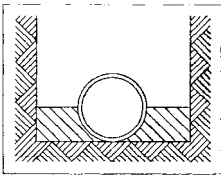
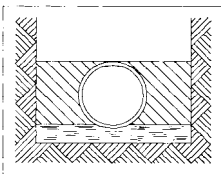
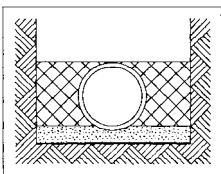
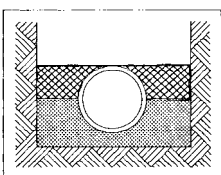
Laying Condition	Description	E' psi ^B	Bedding Angle, °	K _b	K _x
 <p style="text-align: center;">Type 1</p>	Flat-bottom trench ^C loose backfill. ^D	150	30	0.235	0.108
 <p style="text-align: center;">Type 2</p>	Flat-bottom trench ^C Backfill lightly consolidated to centerline of pipe.	300	45	0.210	0.105
 <p style="text-align: center;">Type 3</p>	Pipe bedded in 4-in. (102 mm) min loose soil ^E Backfill lightly consolidated to top of pipe.	400	60	0.189	0.103
 <p style="text-align: center;">Type 4</p>	Pipe bedded in sand, gravel, or crushed stone to depth of 1/8 pipe diameter, 4-in. (102 mm) min. Backfill compacted to top of pipe. (Approximately 80 percent Standard Proctor, AASHTO T-99)	500	90	0.157	0.096
 <p style="text-align: center;">Type 5</p>	Pipe bedded in compacted granular material to centerline of pipe, 4 in. (102 mm) minimum under pipe. Compacted granular or select ^E material to top of pipe. (Approximately 90 percent Standard Proctor, AASHTO T-99)	700	150	0.128	0.085

^A Consideration of the pipe-zone embedment conditions included in this table may be influenced by factors other than pipe strength. For additional information see ANSI/AWWA C600, Standard for installation of Ductile-Iron Water Mains and Their Appurtenances.

^B 1 psi = 6.894757 kPa.

^C Flat-bottom is defined as undisturbed earth.

^D For pipe 14 in. (350 mm) and larger, consideration should be given to use of laying conditions other than Type 1.

^E Loose soil or select material is defined as native soil excavated from the trench, free of rocks, foreign materials, and frozen earth.



TABLE 4 Reduction Factors (R) for Truck Load Calculations

Size, in.	Depth of Cover, ft (m)			
	<4 (1.2)	4 to 7 (1.2 to 2.1)	>7 to 10 (2.4 to 3.0)	>10 (3.0)
	Reduction Factor			
3 to 12	1.00	1.00	1.00	1.00
14	0.92	1.00	1.00	1.00
16	0.88	0.95	1.00	1.00
18	0.85	0.90	1.00	1.00
20	0.83	0.90	0.95	1.00
24 to 30	0.81	0.85	0.95	1.00
36 to 64	0.80	0.85	0.90	1.00

TABLE 5 Allowances for Casting Tolerance

Size, in.	Casting Tolerance, in. (mm)
3-8	0.05 (1.3)
10-12	0.06 (1.5)
14-42	0.07 (1.8)
48	0.08 (2.0)
54-64	0.09 (2.3)

Minimum thickness t_1 for deflection design = $D/(D/t_1)$ = 32.00/136 = 0.24 in.
 Deduct service allowance = -0.08 in.
 Net thickness t for deflection control = 0.16 in.

7.3.3 The larger net thickness is 0.20 in., obtained by the design for bending stress.

Net thickness = 0.20 in.
 Service allowance = 0.08 in.
 Minimum thickness = 0.28 in.
 Casting Tolerance = 0.07 in.
 Total calculated thickness = 0.35 in.

7.3.4 The total calculated thickness of 0.35 in. is larger than 0.34 in., Class 150, in Table 2. Therefore, Class 200 is selected for specifying and ordering.

7.4 Design Method:

7.4.1 Calculations are made for the thicknesses required to resist the bending stress and the deflection caused by trench load. The larger of the two is selected as the thickness required to resist trench load.

7.4.2 To this net thickness is added a service allowance to obtain the minimum manufacturing thickness and a casting tolerance to obtain the total calculated thickness.

7.4.3 The thickness for specifying and ordering is selected from a table of standard pressure-class thicknesses. (Table 2)

7.4.4 The reverse of the above procedure is used to determine the maximum depth of cover for pipe of a given pressure-class.

7.4.5 *Trench Load, P_v* —Trench load is expressed as vertical pressure, psi, and is equal to the sum of earth load, P_e , and truck load, P_t .

7.4.6 *Earth Load, P_e* —Earth load is computed by Eq 3 for the weight of the unit prism of soil with a height equal to the distance from the top of the pipe to the ground surface. The unit weight of backfill soil is taken to be 120 lb/ft³ (18.85 kN/m³). If the designer anticipates additional loads, the design load should be increased accordingly.

7.4.7 *Truck Load, P_t* —The truck loads shown in Table 6 were computed by Eq 4 using the surface load factors in Table

1 and the reduction factors R from Table 4 for a single AASHTO H-20 truck on an unpaved road or flexible pavement, 16 000-lbf (71 kN) wheel load and 1.5 impact factor. The surface load factors in Table 1 were calculated by Eq 5 for a single concentrated wheel load centered over an effective pipe length of 3 ft (0.91 m).

7.4.8 *Design for Trench Load*—Tables 7-11, the diameter-thickness ratios tables used to design for trench load, were computed by Eqs 1 and Eqs 2. Equation 1 is based on the bending stress at the bottom of the pipe. The design bending stress, f , is 48 000 psi (331 MPa) which provides at least a 1.5 safety factor based on minimum ring yield strength and 2.0 safety factor based on ultimate strength. Equation 2 is based on the deflection of the pipe ring section. The design deflection Δ_x is 3 % of the outside diameter of the pipe for cement-lined pipe and 5 % for pipe with flexible linings. Design values of the trench parameters, E' , K_b , and K_x are given in Table 3.

7.4.9 Tables similar to Tables 7-11 may be compiled for laying conditions other than those shown in this specification by calculating the trench loads, P_v , for a series of diameter-thickness ratios, D/t and D/t_1 , using Eqs 1 and Eqs 2 with values of E' , K_b , and K_x appropriate to the bedding and backfill conditions.

7.5 Design Equations:

$$P_v = \frac{f}{3 \left(\frac{D}{t} \right) \left(\frac{D}{t} - 1 \right) \left[K_b - \frac{K_x}{\frac{8E}{E' \left(\frac{D}{t} - 1 \right)^3 + 0.732}} \right]} \quad (1)$$

$$P_v = \frac{\Delta_x}{12K_x} \left[\frac{8E}{\left(\frac{D}{t_1} - 1 \right)^3} + 0.732 E' \right] \quad (2)$$

$$P_e = \frac{wH}{a} \quad (3)$$

$$P_t = RF \frac{CP}{bD} \quad (4)$$

 **A 746 – 99**

TABLE 6 Earth Loads (P_e) Truck Loads (P_t) and Trench Loads (P_v), psi^A

Depth of Cover, ft (m)	P_e	3-in. Pipe		4-in. Pipe		6-in. Pipe		8-in. Pipe		10-in. Pipe		12-in. Pipe		14-in. Pipe		16-in. Pipe		18-in. Pipe		20-in. Pipe	
		P_t	P_v	P_t	P_v	P_t	P_v	P_t	P_v	P_t	P_v	P_t	P_v	P_t	P_v	P_t	P_v	P_t	P_v	P_t	P_v
2.5 (0.8)	2.1	9.9	12.0	9.9	12.0	9.9	12.0	9.8	11.9	9.7	11.8	9.6	11.7	8.7	10.8	8.2	10.3	7.8	9.9	7.5	9.6
3 (0.9)	2.5	7.4	9.9	7.4	9.9	7.3	9.8	7.3	9.8	7.2	9.7	7.2	9.7	6.6	9.1	6.2	8.7	5.9	8.4	5.7	8.2
4 (1.2)	3.3	4.4	7.7	4.5	7.8	4.4	7.7	4.4	7.7	4.4	7.7	4.4	7.7	4.4	7.7	4.1	7.4	3.9	7.2	3.9	7.2
5 (1.5)	4.2	3.0	7.2	3.0	7.2	3.0	7.2	3.0	7.2	2.9	7.1	2.9	7.1	2.9	7.1	2.8	7.0	2.6	6.8	2.6	6.8
6 (1.8)	5.0	2.1	7.1	2.1	7.1	2.1	7.1	2.1	7.1	2.1	7.1	2.1	7.1	2.1	7.1	2.0	7.0	1.9	6.9	1.9	6.9
7 (2.1)	5.8	1.6	7.4	1.6	7.4	1.6	7.4	1.6	7.4	1.6	7.4	1.6	7.4	1.6	7.4	1.5	7.3	1.4	7.2	1.4	7.2
8 (2.4)	6.7	1.2	7.9	1.2	7.9	1.2	7.9	1.2	7.9	1.2	7.9	1.2	7.9	1.2	7.9	1.2	7.9	1.2	7.9	1.1	7.8
9 (2.7)	7.5	1.0	8.5	1.0	8.5	1.0	8.5	1.0	8.5	1.0	8.5	1.0	8.5	1.0	8.5	1.0	8.5	1.0	8.5	0.9	8.4
10 (3.0)	8.3	0.8	9.1	0.8	9.1	0.8	9.1	0.8	9.1	0.8	9.1	0.8	9.1	0.8	9.1	0.8	9.1	0.8	9.1	0.7	9.0
12 (3.7)	10.0	0.6	10.6	0.6	10.6	0.6	10.6	0.6	10.6	0.5	10.5	0.5	10.5	0.5	10.5	0.5	10.5	0.5	10.5	0.5	10.5
14 (4.3)	11.7	0.4	12.1	0.4	12.1	0.4	12.1	0.4	12.1	0.4	12.1	0.4	12.1	0.4	12.1	0.4	12.1	0.4	12.1	0.4	12.1
16 (4.9)	13.3	0.3	13.6	0.3	13.6	0.3	13.6	0.3	13.6	0.3	13.6	0.3	13.6	0.3	13.6	0.3	13.6	0.3	13.6	0.3	13.6
20 (6.1)	16.7	0.2	16.9	0.2	16.9	0.2	16.9	0.2	16.9	0.2	16.9	0.2	16.9	0.2	16.9	0.2	16.9	0.2	16.9	0.2	16.9
24 (7.3)	20.0	0.2	20.2	0.1	20.1	0.1	20.1	0.1	20.1	0.1	20.1	0.1	20.1	0.1	20.1	0.1	20.1	0.1	20.1	0.1	20.1
28 (8.5)	23.3	0.1	23.4	0.1	23.4	0.1	23.4	0.1	23.4	0.1	23.4	0.1	23.4	0.1	23.4	0.1	23.4	0.1	23.4	0.1	23.4
32 (9.8)	26.7	0.1	26.8	0.1	26.8	0.1	26.8	0.1	26.8	0.1	26.8	0.1	26.8	0.1	26.8	0.1	26.8	0.1	26.8	0.1	26.8

Depth of Cover, ft (m)	P_e	24-in. Pipe		30-in. Pipe		36-in. Pipe		42-in. Pipe		48-in. Pipe		54-in. Pipe		60-in. Pipe		64-in. Pipe	
		P_t	P_v	P_t	P_v	P_t	P_v	P_t	P_v	P_t	P_v	P_t	P_v	P_t	P_v	P_t	P_v
2.5 (0.8)	2.1	7.1	9.2	6.7	8.8	6.2	8.3	5.8	7.9	5.4	7.5	5.0	7.1	4.8	6.9	4.5	6.6
3 (0.9)	2.5	5.4	7.9	5.2	7.7	4.9	7.4	4.6	7.1	4.4	6.9	4.1	6.6	3.9	6.4	3.8	6.3
4 (1.2)	3.3	3.6	6.9	3.5	6.8	3.4	6.7	3.3	6.6	3.1	6.4	3.0	6.3	2.9	6.2	2.8	6.1
5 (1.5)	4.2	2.4	6.6	2.4	6.6	2.3	6.5	2.3	6.5	2.2	6.4	2.1	6.3	2.1	6.3	2.1	6.3
6 (1.8)	5.0	1.7	6.7	1.7	6.7	1.7	6.7	1.7	6.7	1.6	6.6	1.6	6.6	1.6	6.6	1.5	6.5
7 (2.1)	5.8	1.3	7.1	1.3	7.1	1.3	7.1	1.3	7.1	1.2	7.0	1.2	7.0	1.2	7.0	1.2	7.0
8 (2.4)	6.7	1.1	7.8	1.1	7.8	1.1	7.8	1.0	7.7	1.0	7.7	1.0	7.7	1.0	7.7	1.0	7.7
9 (2.7)	7.5	0.9	8.4	0.9	8.4	0.8	8.3	0.8	8.3	0.8	8.3	0.8	8.3	0.8	8.3	0.8	8.3
10 (3.0)	8.3	0.7	9.0	0.7	9.0	0.7	9.0	0.7	9.0	0.7	9.0	0.7	9.0	0.7	9.0	0.7	9.0
12 (3.7)	10.0	0.5	10.5	0.5	10.5	0.5	10.5	0.5	10.5	0.5	10.5	0.5	10.5	0.5	10.5	0.5	10.5
14 (4.3)	11.7	0.4	12.1	0.4	12.1	0.4	12.1	0.4	12.1	0.4	12.1	0.4	12.1	0.4	12.1	0.4	12.1
16 (4.9)	13.3	0.3	13.6	0.3	13.6	0.3	13.6	0.3	13.6	0.3	13.6	0.3	13.6	0.3	13.6	0.3	13.6
20 (8.1)	16.7	0.2	16.9	0.2	16.9	0.2	16.9	0.2	16.9	0.2	16.9	0.2	16.9	0.2	16.9	0.2	16.9
24 (7.3)	20.0	0.1	20.1	0.1	20.1	0.1	20.1	0.1	20.1	0.1	20.1	0.1	20.1	0.1	20.1	0.1	20.1
28 (8.5)	23.3	0.1	23.4	0.1	23.4	0.1	23.4	0.1	23.4	0.1	23.4	0.1	23.4	0.1	23.4	0.1	23.4
32 (9.8)	26.7	0.1	26.8	0.1	26.8	0.1	26.8	0.1	26.8	0.1	26.8	0.1	26.8	0.1	26.8	0.1	26.8

^A 1 psi = 6.894757 kPa.

 **A 746 – 99**

**TABLE 7 Diameter-Thickness Ratios for Laying Condition
Type 1**

NOTE 1— $E' = 150 \text{ psi}^A$ $K_b = 0.235$ $K_x = 0.108$

Bending Stress Design	Trench Load P_v , psi^A			Bending Stress Design	Trench Load P_v , psi^A		
	Deflection Design		D/t^B or D/t_1		Deflection Design		D/t^B or D/t_1
	3 % ^C max	5 % ^D max			3 % ^C max	5 % ^D max	
5.17	3.89	6.48	150	8.86	7.12	11.87	100
5.21	3.91	6.52	149	8.99	7.26	12.11	99
5.26	3.94	6.57	148	9.13	7.41	12.35	98
5.30	3.97	6.62	147	9.27	7.57	12.61	97
5.35	4.00	6.67	146	9.41	7.73	12.88	96
5.40	4.03	6.72	145	9.56	7.89	13.15	95
5.45	4.06	6.77	144	9.71	8.07	13.45	94
5.49	4.09	6.82	143	9.87	8.25	13.75	93
5.54	4.13	6.88	142	10.03	8.44	14.07	92
5.59	4.16	6.94	141	10.20	8.64	14.40	91
5.65	4.20	6.99	140	10.37	8.85	14.74	90
5.70	4.23	7.05	139	10.55	9.06	15.11	89
5.75	4.27	7.12	138	10.74	9.29	15.48	88
5.80	4.31	7.18	137	10.93	9.53	15.88	87
5.86	4.35	7.25	136	11.13	9.78	16.30	86
5.91	4.39	7.31	135	11.34	10.04	16.73	85
5.97	4.43	7.38	134	11.55	10.31	17.19	84
6.03	4.47	7.46	133	11.78	10.60	17.67	83
6.09	4.52	7.53	132	12.01	10.90	18.17	82
6.15	4.56	7.61	131	12.25	11.22	18.70	81
6.21	4.61	7.69	130	12.50	11.56	19.26	80
6.27	4.66	7.77	129	12.76	11.91	19.85	79
6.33	4.71	7.85	128	13.03	12.28	20.46	78
6.40	4.76	7.94	127	13.31	12.67	21.11	77
6.46	4.82	8.03	126	13.60	13.08	21.79	76
6.53	4.87	8.12	125	13.91	13.51	22.52	75
6.60	4.93	8.22	124	14.23	13.97	23.28	74
6.67	4.99	8.32	123	14.56	14.45	24.08	73
6.74	5.05	8.42	122	14.91	14.96	24.93	72
6.82	5.11	8.52	121	15.27	15.50	25.83	71
6.89	5.18	8.63	120	15.65	16.07	26.78	70
6.91	5.25	8.74	119	16.05	16.68	27.79	69
7.05	5.32	8.86	118	16.46	17.32	28.86	68
7.13	5.39	8.98	117	16.89	18.00	30.00	67
7.21	5.46	9.11	116	17.35	18.73	31.21	66
7.29	5.54	9.24	115	17.83	19.50	32.49	65
7.38	5.62	9.37	114	18.33	20.32	33.86	64
7.47	5.71	9.51	113	18.85	21.19	35.32	63
7.56	5.79	9.65	112	19.40	22.12	36.87	62
7.65	5.88	9.80	111	19.98	23.12	38.53	61
7.75	5.97	9.96	110	20.59	24.18	40.30	60
7.85	6.07	10.12	109	21.23	25.32	42.20	59
7.95	6.17	10.20	108	21.91	26.54	44.23	58
8.05	6.27	10.46	107	22.63	27.85	46.42	57
8.16	6.38	10.63	106	23.38	29.26	48.76	56
8.27	6.49	10.82	105	24.18	30.77	51.28	55
8.38	6.61	11.01	104	25.02	32.39	53.99	54
8.49	6.73	11.22	103	25.92	34.15	56.92	53
8.61	6.86	11.43	102	26.86	36.05	60.08	52
8.74	6.99	11.64	101	27.87	38.10	63.50	51
28.94	40.32	67.20	50	46.84	83.54	139.23	39
30.07	42.73	71.22	49	49.30	90.28	150.47	38
31.28	45.35	75.58	48	51.96	97.80	163.00	37
32.57	48.20	80.34	47	54.86	106.20	177.00	36
33.95	51.31	85.52	46				
35.42	54.72	91.19	45	58.02	115.62	192.70	35

TABLE 7 *Continued*

Trench Load P_v , psi ^A				Trench Load P_v , psi ^A			
Bending Stress Design	Deflection Design		D/t^B or D/t_1	Bending Stress Design	Deflection Design		D/t^B or D/t_1
	3 % ^C max	5 % ^D max			3 % ^C max	5 % ^D max	
37.00	58.44	97.40	44	61.46	126.21	210.36	34
38.69	62.53	104.22	43	65.23	138.18	230.29	33
40.50	67.03	111.71	42	69.36	151.73	252.88	32
42.46	71.99	119.98	41	73.92	167.15	278.58	31
44.56	77.47	129.11	40	78.94	184.77	307.96	30

^A 1 psi = 6.894757 kPa.

^B The D/t for the tabulated P_v nearest to the calculated P_v is selected. When the calculated P_v is halfway between two tabulated values, the smaller D/t should be used.

^C Maximum 3 % deflection is recommended for rigid or semirigid linings such as cement mortar.

^D Maximum 5 % deflection is recommended for flexible linings such as asphaltic and plastic.

$$C = 1 - \frac{2}{3} \arcsin \left[H \sqrt{\frac{A^2 + B^2 + H^2}{(A^2 + H^2)(H^2 + B^2)}} \right] + \frac{2}{\pi} \left(\frac{A \cdot H \cdot B}{\sqrt{A^2 + H^2 + B^2}} \right) \left(\frac{1}{A^2 + H^2} + \frac{1}{B^2 + H^2} \right) \quad (5)$$

NOTE 4—In Eq 5, angles are in radians.

8. Hydrostatic Test

8.1 Each pipe shall be subjected to a hydrostatic test of not less than 500 psi (3.45 MPa). This test may be performed either before or after the outside coating and inside coating have been applied, but shall be performed before the application of cement-mortar lining or of a special lining.

8.2 The pipe shall be under the full test pressure for at least 10 s. Suitable controls and recording devices shall be provided so that the test pressure and duration are adequately ascertained. Any pipe that leaks or does not withstand the test pressure shall be rejected.

8.3 In addition to the hydrostatic test before application of a cement-mortar lining or special lining, the pipe may be retested, at the manufacturer's option, after the application of such a lining.

9. Acceptance Tests

9.1 The standard acceptance tests for the physical characteristics of the pipe shall be as follows:

9.2 *Tension Test*—Unless otherwise specified by the purchaser, a tension test specimen shall be cut longitudinally or circumferentially from the midsection of the pipe wall. In case of dispute, the test specimen shall be cut longitudinally. This specimen shall be machined and tested in accordance with Fig. 1 and Test Methods E 8. The yield strength shall be determined by the 0.2 % offset, half-of-pointer, or extension-under-load methods. If check tests are to be made, the 0.2 % offset method shall be used. All specimens shall be tested at room temperature $70 \pm 10^\circ\text{F}$ ($21 \pm 6^\circ\text{C}$).

9.2.1 *Acceptable Values*—The acceptance values for test specimens shall be as follows:

Grade of Iron:	60–42–10
Minimum tensile strength, psi (MPa)	60 000 (413.7)
Minimum yield strength, psi (MPa):	42 000 (289.6)
Minimum elongation, %:	10

9.3 *Impact Test*—Tests shall be made in accordance with Test Methods E 23, except that dimensions of the specimens shall be 0.500 in. (12.70 mm) by full thickness of pipe wall. Unless otherwise specified by the purchaser, the notched impact test specimen shall be in accordance with Fig. 2 except that it may be cut circumferentially. In case of dispute, the specimen shall be cut in accordance with Fig. 2. If the pipe wall thickness exceeds 0.40 in. (10.2 mm), the impact specimen may be machined to a nominal thickness of 0.40 in. In all tests, impact values are to be corrected to a standard wall thickness, $t_s = 0.40$ in., by calculation as follows:

$$\text{Impact value (corrected)} = \frac{t_s}{t} \times \text{impact value (actual)}$$

where: t = the thickness of the specimen, in. (mm).

The Charpy test machine anvil shall not be moved to compensate for the variation of cross-section dimensions of the test specimens.

9.3.1 *Acceptance Value*—The corrected acceptance value for notched impact test specimens shall be a minimum of 7 ft·lbf (9.49 J) for tests conducted at $70 \pm 10^\circ\text{F}$ ($21 \pm 6^\circ\text{C}$).

9.4 *Sampling*—At least one tension sample shall be taken during each casting period of approximately 3 h. At least one $70 \pm 10^\circ\text{F}$ ($21 \pm 6^\circ\text{C}$) Charpy impact sample shall be taken during each operating hour. Samples shall be selected to properly represent extremes of pipe diameters and wall thicknesses.

10. Additional Control Tests by Manufacturer

10.1 An additional low-temperature impact test shall be made from at least 10 % of the sample coupons taken for the required $70 \pm 10^\circ\text{F}$ ($21 \pm 6^\circ\text{C}$) Charpy impact test specified in 9.4 to check compliance with a minimum corrected value of 3 ft·lbf (4 J) for tests conducted at -40°F (-40°C). Test specimens shall be prepared and tested in accordance with 9.3.



**TABLE 8 Diameter-Thickness Ratios for Laying Condition
Type 2**

NOTE 1— $E' = 300 \text{ psi}^A$ $K_b = 0.210$ $K_x = 0.105$

Bending Stress Design	Trench Load P_v , psi^A			Bending Stress Design	Trench Load P_v , psi^A		
	Deflection Design		D/t^B or D/t_1		Deflection Design		D/t^B or D/t_1
	3 % ^C max	5 % ^D max			3 % ^C max	5 % ^D max	
7.42	6.61	11.02	150	12.01	9.94	16.57	100
7.48	6.64	11.06	149	12.16	10.09	16.81	99
7.54	6.67	11.11	148	12.31	10.24	17.06	98
7.61	6.70	11.16	147	12.46	10.40	17.33	97
7.67	6.73	11.21	146	12.62	10.56	17.60	96
7.74	6.76	11.27	15	12.79	10.73	17.89	95
7.80	6.79	11.32	144	12.96	10.91	18.19	94
7.87	6.83	11.38	143	13.13	11.10	18.50	93
7.94	6.86	11.43	142	13.31	11.29	18.82	92
8.01	6.89	11.49	141	13.49	11.50	19.17	91
8.08	6.93	11.55	140	13.68	11.71	19.52	90
8.15	6.97	11.61	139	13.88	11.94	19.89	89
8.22	7.01	11.68	138	14.08	12.17	20.28	88
8.29	7.05	11.74	137	14.30	12.42	20.69	87
8.37	7.09	11.81	135	14.51	12.67	21.12	86
8.44	7.13	11.88	135	14.74	12.94	21.57	85
8.52	7.17	11.95	134	14.97	13.22	22.04	84
8.59	7.22	12.03	133	15.21	13.52	22.53	83
8.67	7.26	12.10	132	15.46	13.83	23.05	82
8.75	7.31	12.18	131	15.72	14.16	23.60	81
8.83	7.36	12.26	130	15.99	14.50	24.17	80
8.91	7.41	12.35	129	16.28	14.86	24.77	79
8.99	7.46	12.43	128	16.57	15.24	25.40	78
9.07	7.51	12.52	127	16.87	15.64	26.07	77
9.16	7.57	12.62	126	17.19	16.06	26.77	76
9.25	7.63	12.71	125	17.52	16.51	27.52	75
9.33	7.69	12.81	124	17.86	16.98	28.30	74
9.42	7.75	12.91	123	18.22	17.48	29.13	73
9.51	7.81	13.02	122	18.59	18.00	30.00	72
9.60	7.87	13.12	121	18.98	18.56	30.93	71
9.70	7.94	13.24	120	19.39	19.14	31.91	70
9.79	8.01	13.35	119	19.82	19.77	32.95	69
9.89	8.08	13.47	118	20.27	20.43	34.05	68
9.99	8.16	13.60	117	20.73	21.13	35.22	67
10.09	8.23	13.72	116	21.23	21.87	36.46	66
10.19	8.31	13.86	115	21.74	22.67	37.78	65
10.29	8.40	13.99	114	22.28	23.51	39.18	64
10.40	8.48	14.14	113	22.85	24.41	40.68	63
10.51	8.57	14.29	112	23.45	25.37	42.28	62
10.62	8.66	14.44	111	24.07	26.39	43.99	61
10.73	8.76	14.60	110	24.74	27.49	45.81	60
10.84	8.86	14.76	109	25.43	28.66	47.76	59
10.96	8.96	14.93	108	26.17	29.91	49.86	58
11.08	9.07	15.11	107	26.95	31.26	52.10	57
11.21	9.18	15.30	106	27.77	32.71	54.521	56
11.33	9.29	15.49	105	28.64	34.26	57.10	55
11.46	9.41	15.69	104	29.56	35.93	59.89	54
11.59	9.54	15.89	103	30.53	37.74	62.90	53
11.73	9.67	16.11	102	31.57	39.69	66.15	52
11.87	9.80	16.33	101	32.67	41.80	69.67	51
33.84	44.09	73.48	50	51.06	82.29	137.16	40
35.08	46.56	77.61	49	53.57	88.54	147.57	39
36.41	49.26	82.10	48	56.30	95.48	159.13	38
37.83	52.19	86.99	47	59.25	103.21	172.02	37
39.34	55.40	92.33	46	62.46	111.85	186.42	36
40.96	58.89	98.16	45	65.96	121.54	202.56	35
42.70	62.73	104.54	44	69.79	132.44	220.73	34

TABLE 8 *Continued*

Trench Load P_v , psi ^A				Trench Load P_v , psi ^A			
Bending Stress Design	Deflection Design		D/t^B or D/t_1	Bending Stress Design	Deflection Design		D/t^B or D/t_1
	3 % ^C max	5 % ^D max			3 % ^C max	5 % ^D max	
44.57	66.93	111.55	43	73.98	144.74	241.23	33
46.57	71.56	119.26	42	78.57	158.68	264.46	32
48.73	76.66	127.76	41	83.64	174.54	290.90	31
				89.23	192.67	321.11	30

^A 1 psi = 6.894757 kPa.

^B The D/t for the tabulated P_v nearest to the calculated P_v is selected. When the calculated P_v is halfway between two tabulated values, the smaller D/t should be used.

^C Maximum 3 % deflection is recommended for rigid or semirigid linings such as cement mortar.

^D Maximum 5 % deflection is recommended for flexible linings such as asphaltic and plastic.

10.2 In addition, the manufacturer shall conduct such other tests as may be necessary to ensure compliance with this specification.

11. Additional Tests Required by Purchaser

11.1 When tests other than those required in this specification are required by the purchaser, such tests shall be specified in the purchaser's specifications.

12. Inspection and Certification by Manufacturer

12.1 Unless otherwise provided in the purchaser's specifications, the manufacturer shall establish the necessary quality-control and inspection practice to ensure compliance with this specification.

12.2 The manufacturer shall, if required on the purchaser's specifications, furnish a sworn statement that the inspection and all of the specified tests have been made and that all results thereof comply with the requirements of this specification.

12.3 All pipes shall be clean and sound without defects that could impair service. Repairing of defects by welding or other methods shall not be allowed if such repairs could adversely affect the serviceability of the pipe or its capability to meet strength requirements of this specification.

13. Defective Specimens and Retests

13.1 When any physical test specimen shows defective machining or lack of continuity of metal, it shall be discarded and replaced by another specimen. When any sound test specimen fails to meet the specified requirements, the pipe from which it was taken shall be rejected, and a retest may be made on two additional sound specimens taken from pipe cast in the same period as the specimen that failed. Both of the additional specimens shall meet the prescribed tests in order to qualify the pipe produced in that period.

14. Inspection by Purchaser

14.1 If the purchaser desires to inspect pipe at the manufacturer's plant, the purchaser shall so state in the purchaser's specifications and describe the conditions (such as time and the extent of inspection) under which the inspection shall be made.

14.2 The purchaser's representative shall have free access to those areas of the manufacturer's plant that are necessary to

determine compliance with this specification. The manufacturer shall make available for the use of the purchaser's representative such gages as are necessary for inspection. The manufacturer shall provide the purchaser's representative with assistance as necessary for handling of pipe.

15. Delivery and Acceptance

15.1 All pipe and accessories shall comply with this specification. Pipe and accessories not complying with this specification shall be replaced by the manufacturer at the agreed point of delivery. The manufacturer shall not be liable for shortages or damaged pipe after acceptance at the agreed point of delivery, except as recorded on the delivery receipt or similar document by the carrier's agent. See Tables 12-14.

16. Foundry Records

16.1 The results of the acceptance tests (Section 9) and low-temperature impact tests (Section 10) shall be recorded and retained for 1 year, and shall be available to the purchaser at the foundry. Written transcripts shall be furnished, if required by the purchaser's specification.

17. Rejection of Pipe

17.1 If the results of any physical acceptance test fail to meet the requirements of Sections 9, 10, or 13, all pipe cast in the same period shall be rejected, except as provided in Section 18.

18. Determining Rejection

18.1 The manufacturer may determine the amount of pipe to be rejected by making similar additional tests of pipe, of the same size as the rejected pipe, until the rejected lot is bracketed, in order of manufacture, by an acceptable test at each end of the interval in question. When pipe of one size is rejected from a casting period, the acceptability of pipe of different sizes from that same period may be established by developing the acceptance tests for these sizes as specified in Section 9.

19. Marking Pipe

19.1 The weight, class, or nominal thickness, and casting period shall be shown on each pipe. The manufacturer's mark,



**TABLE 9 Diameter-Thickness Ratios for Laying Condition
Type 3**

NOTE 1— $E' = 400 \text{ psi}^A$ $K_b = 0.189$ $K_x = 0.103$

Bending Stress Design	Trench Load P_v , psi^A			Bending Stress Design	Trench Load P_v , psi^A		
	Deflection Design		D/t^B or D/t_1		Deflection Design		D/t^B or D/t_1
	3 % ^C max	5 % ^D max			3 % ^C max	5 % ^D max	
10.00	8.52	14.19	150	15.39	11.91	19.85	100
10.08	8.54	14.24	149	15.55	12.06	20.10	99
10.16	8.57	14.29	148	15.71	12.21	20.35	98
10.24	8.60	14.34	147	15.88	12.37	20.62	97
10.33	8.64	14.39	146	16.06	12.54	20.90	96
10.41	8.67	14.45	145	16.23	12.72	21.20	95
10.49	8.70	14.50	144	16.42	12.90	21.50	94
10.58	8.73	14.56	143	16.61	13.09	21.82	93
10.66	8.77	14.62	142	16.80	13.29	22.15	92
10.75	8.81	14.68	141	17.00	13.50	22.50	91
10.83	8.84	14.74	140	17.21	13.72	22.86	90
10.92	8.88	14.80	139	17.42	13.95	23.24	89
11.01	8.92	14.87	138	17.64	14.18	23.64	88
11.10	8.96	14.93	137	17.86	14.43	24.06	87
11.19	9.00	15.00	136	18.10	14.70	24.49	86
11.28	9.04	15.07	135	18.34	14.97	24.95	85
11.37	9.09	15.15	134	18.59	15.26	25.43	84
11.46	9.13	15.22	133	18.85	15.56	25.93	83
11.56	9.18	15.30	132	19.12	15.88	26.46	82
11.65	9.23	15.38	131	19.40	16.21	27.01	81
11.75	9.28	15.46	130	19.68	16.56	27.60	80
11.84	9.33	15.55	129	19.99	16.93	28.21	79
11.94	9.38	15.64	128	20.30	17.31	28.86	78
12.04	9.44	15.73	127	20.62	17.72	29.54	77
12.14	9.49	15.82	126	20.96	18.15	30.26	76
12.25	9.55	15.92	125	21.31	18.61	31.01	75
12.35	9.61	16.02	124	21.68	19.09	31.81	74
12.45	9.67	16.12	123	22.07	19.59	32.65	73
12.56	9.74	16.23	122	22.47	20.13	33.55	72
12.67	9.80	16.34	121	22.88	20.69	34.49	71
12.78	9.87	16.45	120	23.32	21.29	35.49	70
12.89	9.94	16.57	119	23.78	21.93	36.55	69
13.00	10.02	16.69	118	24.26	22.60	37.67	68
13.11	10.09	16.82	117	24.76	23.32	38.86	67
13.23	10.17	16.95	116	25.29	24.08	40.13	66
13.34	10.25	17.09	115	25.85	24.88	41.47	65
13.46	10.34	17.23	114	26.43	25.74	42.91	64
13.58	10.42	17.37	113	27.04	26.66	44.43	63
13.71	10.51	17.52	112	27.68	27.64	46.06	62
13.83	10.61	17.68	111	28.36	28.68	47.80	61
13.96	10.71	17.84	110	29.08	29.80	49.66	60
14.09	10.81	18.01	109	29.83	30.99	51.65	59
14.22	10.91	18.18	108	30.63	32.27	53.78	58
14.36	11.02	18.37	107	31.47	33.64	56.07	57
14.50	11.13	18.55	106	32.36	35.12	58.53	56
14.64	11.25	18.75	105	33.31	36.70	61.17	55
14.78	11.37	18.95	104	34.30	38.41	64.02	54
14.93	11.50	19.16	103	35.37	40.25	67.08	53
15.08	11.63	19.38	102	36.49	42.24	70.40	52
15.23	11.77	19.61	101	37.69	44.39	73.98	51
38.97	46.72	77.86	50	57.84	85.67	142.78	40
40.33	49.25	82.08	49	60.61	92.04	153.39	39
41.78	51.99	86.65	48	63.61	99.11	165.18	38
43.33	54.98	91.64	47	66.86	106.99	178.32	37
44.98	58.25	97.08	46	70.40	115.80	193.00	36
				74.27	125.67	209.46	35



TABLE 9 *Continued*

Trench Load P_v , psi ^A				Trench Load P_v , psi ^A			
Bending Stress Design	Deflection Design		D/t^B or D/t_1	Bending Stress Design	Deflection Design		D/t^B or D/t_1
	3 % ^C max	5 % ^D max			3 % ^C max	5 % ^D max	
46.76	61.81	103.02	45	78.49	136.78	227.97	34
48.66	65.72	109.53	44	83.11	149.32	248.87	33
50.71	70.01	116.68	43	88.19	163.54	272.56	32
52.91	74.72	124.54	42	93.79	179.71	299.51	31
55.28	79.92	133.20	41	99.97	198.18	330.31	30

^A 1 psi = 6.894757 kPa.

^B The D/t for the tabulated P_v nearest to the calculated P_v is selected. When the calculated P_v is halfway between two tabulated values, the smaller D/t should be used.

^C Maximum 3 % deflection is recommended for rigid or semirigid linings such as cement mortar.

^D Maximum 5 % deflection is recommended for flexible linings such as asphaltic and plastic.

the country where cast, the year in which the pipe was produced, and the letters “DI” or “DUCTILE” shall be cast or metal stamped on the pipe and letters and numbers on pipe sizes 14 in. (356 mm) and larger shall be not less than ½ in. (13 mm) in height. When required in the purchaser’s specifications, initials not exceeding four in number shall be cast or stamped on the pipe. All required markings shall be clear and legible, and all cast or metal stamped marks shall be on or near the bell.

20. Weighing Pipe

20.1 Each pipe shall be weighed before the application of any lining or coating other than the asphaltic coating and the weight shown on the outside or inside of the bell or spigot end.

21. Keywords

21.1 ductile iron sewer pipe; elongation; laying conditions; mechanical properties; tensile strength; yield strength



**TABLE 10 Diameter-Thickness Ratios for Laying Condition
Type 4**

NOTE 1— $E' = 500 \text{ psi}^A$ $K_b = 0.157$ $K_x = 0.096$

Bending Stress Design	Trench Load P_v , psi ^A			Bending Stress Design	Trench Load P_v , psi ^A		
	Deflection Design		D/t^B or D/t_1		Deflection Design		D/t^B or D/t_1
	3 % ^C max	5 % ^D max			3 % ^C max	5 % ^D max	
16.34	11.04	18.40	150	22.49	14.68	24.47	100
16.45	11.07	18.46	149	22.66	14.84	24.74	99
16.55	11.11	18.51	148	22.83	15.01	25.02	98
16.65	11.14	18.56	147	23.01	15.18	25.30	97
16.76	11.17	18.62	146	23.20	15.36	25.61	96
16.86	11.21	18.68	145	23.38	15.55	25.92	95
16.96	11.24	18.74	144	23.58	15.75	26.25	94
17.07	11.28	18.80	143	23.78	15.95	26.59	93
17.18	11.31	18.86	142	23.99	16.17	26.94	92
17.28	11.35	18.92	141	24.20	16.39	27.32	91
17.39	11.39	18.99	140	24.42	16.62	27.71	90
17.50	11.43	19.06	139	24.64	16.87	28.11	89
17.60	11.48	19.13	138	24.88	17.12	28.54	88
17.71	11.52	19.20	137	25.12	17.39	28.99	87
17.82	11.56	19.27	136	25.37	17.67	29.45	86
17.93	11.61	19.35	135	25.63	17.97	29.95	85
18.04	11.66	19.43	134	25.90	18.28	30.46	84
18.15	11.71	19.51	133	26.18	18.60	31.00	83
18.26	11.76	19.59	132	26.47	18.94	31.57	82
18.37	11.81	19.68	131	26.77	19.30	32.16	81
18.49	11.86	19.77	130	27.09	19.67	32.79	80
18.60	11.92	19.86	129	27.42	20.07	33.45	79
18.72	11.97	19.95	128	27.76	20.48	34.14	78
18.83	12.03	20.05	127	28.11	20.92	34.87	77
18.95	12.09	20.15	126	28.49	21.38	35.64	76
19.06	12.15	20.26	125	28.87	21.87	36.45	75
19.18	12.22	20.36	124	29.28	22.38	37.31	74
19.30	12.28	20.47	123	29.70	22.93	38.21	73
19.42	12.35	20.59	122	30.15	23.50	39.17	72
19.54	12.42	20.71	121	30.62	24.11	40.18	71
19.66	12.50	20.83	120	31.11	24.75	41.25	70
19.78	12.57	20.96	119	31.62	25.43	42.39	69
19.91	12.65	21.09	118	32.16	26.16	43.59	68
20.04	12.73	21.22	117	32.72	26.92	44.87	67
20.16	12.82	21.36	116	33.32	27.74	46.23	66
20.29	12.91	21.51	115	33.95	28.60	47.67	65
20.42	13.00	21.66	114	34.61	29.53	49.21	64
20.55	13.09	21.82	113	35.30	30.51	50.85	63
20.69	13.19	21.98	112	36.04	31.56	52.60	62
20.82	13.29	22.15	111	36.81	32.68	54.47	61
20.96	13.39	22.32	110	37.63	33.88	56.46	60
21.10	13.50	22.50	109	38.50	35.16	58.60	59
21.24	13.61	22.69	108	39.42	36.53	60.88	58
21.39	13.73	22.88	107	40.39	38.00	63.34	57
21.54	13.85	23.08	106	41.42	39.58	65.97	56
21.69	13.98	23.29	105	42.51	41.28	68.81	55
21.84	14.11	23.51	104	43.67	43.12	71.86	54
22.00	14.24	23.74	103	44.91	45.09	75.15	53
22.16	14.38	23.97	102	46.22	47.22	78.71	52
22.32	14.53	24.22	101	47.62	49.53	82.55	51
49.11	52.03	86.72	50	71.39	93.82	156.37	40
50.70	54.74	91.24	49	74.67	100.65	167.75	39
52.41	57.69	96.15	48	78.24	108.24	180.40	38
54.23	60.90	101.50	47	82.11	116.70	194.50	37
56.18	64.40	107.33	46	86.33	126.15	210.25	36
				90.93	136.74	227.91	35

 **A 746 – 99**

TABLE 10 *Continued*

Trench Load P_v , psi ^A				Trench Load P_v , psi ^A			
Bending Stress Design	Deflection Design		D/t^B or D/t_1	Bending Stress Design	Deflection Design		D/t^B or D/t_1
	3 % ^C max	5 % ^D max			3 % ^C max	5 % ^D max	
58.27	68.23	113.71	45	95.97	148.66	247.77	34
60.52	72.42	120.70	44	101.49	162.12	270.20	33
62.93	77.02	128.36	43	107.56	177.37	295.61	32
65.54	82.08	136.80	42	114.25	194.72	324.53	31
68.35	87.66	146.09	41	121.65	214.54	357.57	30

^A 1 psi = 6.894757 kPa.

^B The D/t for the tabulated P_v nearest to the calculated P_v is selected. When the calculated P_v is halfway between two tabulated values, the smaller D/t should be used.

^C Maximum 3

^D Maximum 5 % deflection is recommended for flexible linings such as asphaltic and plastic.



**TABLE 11 Diameter-Thickness Ratios for Laying Condition
Type 5**

NOTE 1— $E' = 700 \text{ psi}^A$ $K_b = 0.128$ $K_x = 0.085$

Bending Stress Design	Trench Load P_v , psi ^A			Bending Stress Design	Trench Load P_v , psi ^A		
	Deflection Design		D/t^B or D/t_1		Deflection Design		D/t^B or D/t_1
	3 % ^C max	5 % ^D max			3 % ^C max	5 % ^D max	
30.21	16.78	27.96	150	36.54	20.89	34.82	100
30.34	16.81	28.02	149	36.69	21.07	35.12	99
30.48	16.85	28.08	148	36.85	21.26	35.43	98
30.61	16.89	28.14	147	37.01	21.45	35.76	97
30.74	16.92	28.20	146	37.17	21.66	36.10	96
30.87	16.96	28.27	145	37.34	21.87	36.45	95
30.99	17.00	28.34	144	37.52	22.09	36.82	94
31.12	17.04	28.40	143	37.70	22.32	37.20	93
31.25	17.09	28.48	142	37.89	22.56	37.61	92
31.38	17.13	28.55	141	38.08	22.82	38.03	91
31.50	17.17	28.62	140	38.28	23.08	38.47	90
31.63	17.22	28.70	139	38.49	23.36	38.93	89
31.76	17.27	28.78	138	38.71	23.65	39.41	88
31.88	17.32	28.86	137	38.93	23.95	39.91	87
32.01	17.37	28.94	136	39.17	24.27	40.44	86
32.13	17.42	29.03	135	39.41	24.60	41.00	85
32.25	17.47	29.12	134	39.67	24.95	41.58	84
32.38	17.53	29.21	133	39.94	25.31	42.19	83
32.50	17.58	29.30	132	40.22	25.70	42.83	82
32.62	17.64	29.40	131	40.51	26.10	43.50	81
32.75	17.70	29.50	130	40.82	26.52	44.21	80
32.87	17.76	29.61	129	41.14	26.97	44.95	79
32.99	17.83	29.71	128	41.48	27.44	45.73	78
33.11	17.89	29.82	127	41.84	27.93	46.56	77
33.23	17.96	29.94	126	42.21	28.46	47.43	76
33.35	18.03	30.05	125	42.60	29.01	48.34	75
33.47	18.11	30.18	124	43.02	29.59	49.31	74
33.59	18.18	30.30	123	43.45	30.20	50.33	73
33.71	18.26	30.43	122	43.92	30.85	51.41	72
33.83	18.34	30.56	121	44.40	31.53	52.56	71
33.95	18.42	30.70	120	44.91	32.26	53.77	70
34.07	18.51	30.85	119	45.46	33.03	55.05	69
34.19	18.60	30.99	118	46.03	33.85	56.41	68
34.31	18.69	31.15	117	46.64	34.71	57.85	67
34.43	18.78	31.31	116	47.28	35.63	59.39	66
34.55	18.88	31.47	115	47.96	36.61	61.02	65
34.68	18.98	31.64	114	48.68	37.65	62.76	64
34.80	19.09	31.82	113	49.44	38.77	64.61	63
34.92	19.20	32.00	112	50.25	39.95	66.58	62
35.05	19.31	32.19	111	51.11	41.21	68.69	61
35.17	19.43	32.39	110	52.02	42.57	70.94	60
35.30	19.55	32.59	109	52.99	44.01	73.36	59
35.43	19.68	32.80	108	54.02	45.56	75.94	58
35.56	19.81	33.02	107	55.12	47.23	78.71	57
35.69	19.95	33.25	106	56.28	49.01	81.69	56
35.83	20.09	33.48	105	57.53	50.93	84.89	55
35.96	20.24	33.73	104	58.86	53.00	88.34	54
36.10	20.39	33.99	103	60.28	55.23	92.05	53
36.25	20.55	34.25	102	61.79	57.64	96.07	52
36.39	20.72	34.53	101	63.41	60.25	100.41	51
65.14	63.07	105.12	50	91.47	110.27	183.78	40
67.00	66.13	110.22	49	95.40	117.98	196.64	39
68.99	69.46	115.77	48	99.67	126.56	210.93	38
71.12	73.09	121.81	47	104.32	136.11	226.84	37
73.41	77.04	128.40	46	109.40	146.78	244.63	36
75.88	81.36	135.61	45	114.94	158.75	264.58	35

ASTM A 746 – 99

TABLE 11 Continued

Trench Load P_v , psi ^A				Trench Load P_v , psi ^A			
Bending Stress Design	Deflection Design		D/t^B or D/t_1	Bending Stress Design	Deflection Design		D/t^B or D/t_1
	3 % ^C max	5 % ^D max			3 % ^C max	5 % ^D max	
78.54	86.10	143.49	44	121.02	172.21	287.01	34
81.40	91.29	152.15	43	127.69	187.41	312.34	33
84.50	97.01	161.68	42	135.03	204.63	341.04	32
87.85	103.31	172.18	41	143.14	224.22	373.70	31
				152.11	246.61	411.02	30

^A 1 psi = 6.894757 kPa.
^B The D/t for the tabulated P_v nearest to the calculated P_v is selected. When the calculated P_v is halfway between two tabulated values, the smaller D/t should be used.
^C Maximum 3 % deflection is recommended for rigid or semirigid linings such as cement mortar.
^D Maximum 5 % deflection is recommended for flexible linings such as asphaltic and plastic.

NOTE 1—The reduced section (A) may have a gradual taper from the ends toward the center with the ends not more than 0.005 in. (0.13 mm) larger in diameter than the center on the standard specimen and not more than 0.003 in. (0.08 mm) larger in diameter than the center on the small size specimens.

NOTE 2—If desired, on the small size specimens the length of the reduced section may be increased to accommodate an extensometer. However, reference marks for the measurement of elongation should nevertheless be spaced at the indicated gage length (G).

NOTE 3—The gage length and fillets shall be as shown, but the ends may be of any form to fit the holders of the testing machine in such a way that the load shall be axial. If the ends are to be held in grips it is desirable, if possible to make the length of the grip section great enough to allow the specimen to extend into the grips a distance equal to two thirds or more of the length of the grips.

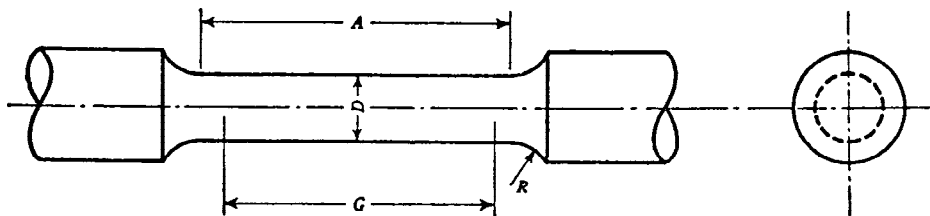

Dimension	Standard Specimen 0.50-in		Small-Size Specimens Proportional to Standard				
	(12.7-mm) Round	0.350-in. (8.89-mm) Round	0.250-in. (6.35-mm) Round	0.175-in. (4.45-mm) Round	0.125-in. (3.18-mm) Round		
Dimensions, in. (mm)							
G	2.000 ± 0.005 (50.80 ± 0.13)	1.400 ± 0.005 (35.56 ± 0.13)	1.000 ± 0.005 (25.40 ± 0.13)	0.700 ± 0.005 (17.78 ± 0.13)	0.500 ± 0.005 (12.70 ± 0.13)		
D	0.500 ± 0.010 (12.70 ± 0.25)	0.350 ± 0.007 (8.89 ± 0.18)	0.250 ± 0.005 (6.35 ± 0.13)	0.175 ± 0.005 (4.44 ± 0.13)	0.125 ± 0.005 (3.18 ± 0.13)		
R, min	3/8 (9.5)	1/4 (6.4)	3/16 (4.8)	3/32 (2.4)	3/32 (2.4)		
A, min	2 1/4 (57.2)	1 3/4 (44.4)	1 1/4 (31.8)	3/4 (19)	5/8 (15.9)		
T ^A	0.71 and greater (18.0)	0.50 to 0.70 (12.2 to 17.8)	0.35 to 0.49 (8.9 to 12.4)	0.25 to 0.34 (6.4 to 8.6)	0.18 to 0.24 (4.6 to 6.1)		

^A Thickness of the section from the wall of the pipe from which the tension specimen is to be machined.

FIG. 1 Tension Test Specimen

NOTE 1— t = pipe-wall thickness.

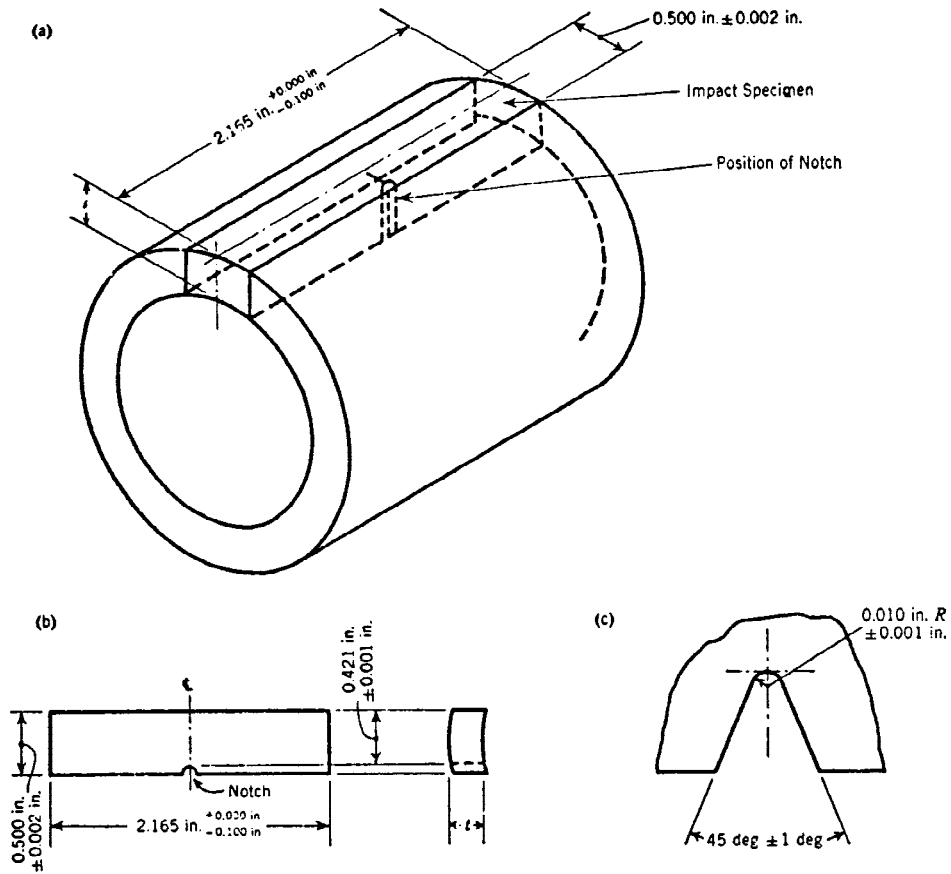

Test Specimen Detail		Notch Detail	
in.	mm	in.	mm
-0.100	-2.54	0.100	2.54
+0.000	+0.00	0.421	10.69
0.001	0.03	0.500	12.70
0.002	0.05	2.165	54.99
0.010	0.25		

FIG. 2 Impact Test Specimen



TABLE 12 Pipe Selection Table (Cement-Lined Pipe)

NOTE 1—Ring deflection limited to 3 %, minimum safety factor of 2.

NOTE 2—Earth load (P_e) of 120 pcf.

Pipe Size, in.	Pressure Class	Nominal Thickness, in.	Laying Condition				
			Type 1	Type 2	Type 3	Type 4	Type 5
			Maximum Depth of Cover, ft ^A				
3	350	0.25	78	88	99	<i>B</i>	<i>B</i>
4	350	0.25	53	61	69	85	<i>B</i>
6	350	0.25	26	31	37	47	65
8	350	0.25	16	20	25	34	50
10	350	0.26	11 ^C	15	19	28	45
12	350	0.28	10 ^C	15	19	28	44
14	250	0.28	<i>D</i>	11 ^C	15	23	36
	300	0.30		13	17	26	42
	350	0.31		14	19	27	44
16	250	0.30	<i>D</i>	11 ^C	15	24	34
	300	0.32		13	17	26	39
	350	0.34		15	20	28	44
18	250	0.31	<i>D</i>	10 ^C	14	22	31
	300	0.34		13	17	26	36
	350	0.36		15	19	28	41
20	250	0.33	<i>D</i>	10	14	22	30
	300	0.36		13	17	26	35
	350	0.38		15	19	28	38
24	200	0.33	<i>D</i>	8 ^C	12	17	25
	250	0.37		11	15	20	29
	300	0.40		13	17	24	32
	350	0.43		15	19	28	37
30	150	0.34	<i>D</i>	...	9	14	22
	200	0.38		8 ^C	12	16	24
	250	0.42		11	15	19	27
	300	0.45		12	16	21	29
	350	0.49		15	19	25	33
36	150	0.38	<i>D</i>	...	9	14	21
	200	0.42		8 ^C	12	15	23
	250	0.47		10	14	18	25
	300	0.51		12	16	20	28
	350	0.56		15	19	24	32
42	150	0.41	<i>D</i>	...	9	13	20
	200	0.47		8	12	15	22
	250	0.52		10	14	17	25
	300	0.57		12	16	20	27
	350	0.63		15	19	23	32
48	150	0.46	<i>D</i>	...	9	13	20
	200	0.52		8	11	15	22
	250	0.58		10	13	17	24
	300	0.64		12	15	19	27
	350	0.70		15	18	22	30
54	150	0.51	<i>D</i>	...	9	13	20
	200	0.58		8	11	14	22
	250	0.65		10	13	16	24
	300	0.72		13	15	19	27
	350	0.79		15	18	22	30
60	150	0.54	<i>D</i>	5 ^C	9	13	20
	200	0.61		8	11	14	22
	250	0.68		10	13	16	24
	300	0.76		13	15	19	26
	350	0.83		15	18	22	30
64	150	0.56	<i>D</i>	5 ^C	9	13	20
	200	0.64		8	11	14	21
	250	0.72		10	13	16	24
	300	0.80		12	15	19	26
	350	0.87		15	17	21	29

^A These pipes are adequate for depths of cover from 2.5 ft up to the maximum shown including an allowance for a single H-20 truck with 1.5 impact factor unless noted.

^B Calculated maximum depth of cover exceeds 100 ft.

^C Minimum allowable depth of cover is 3 ft.

^D For pipe 14 in. and larger, consideration should be given to the use of laying conditions other than Type 1.



TABLE 13 Pipe Selection Table (Pipe with Flexible Lining)

NOTE 1—Examples of flexible linings include polyethylene, epoxy, asphaltic, etc.

NOTE 2—Ring deflection limited to 5 %, minimum safety factor of 2.

NOTE 3—Earth load (P_e) of 120 pcf.

Pipe Size, in.	Pressure Class	Nominal Thickness, in.	Laying Condition				
			Type 1	Type 2	Type 3	Type 4	Type 5
			Maximum Depth of Cover, ft ^A				
3	350	0.25	78	88	99	<i>B</i>	<i>B</i>
4	350	0.25	53	61	69	85	<i>B</i>
6	350	0.25	26	31	37	47	65
8	350	0.25	16	20	25	34	50
10	350	0.26	11 ^C	15	19	28	45
12	350	0.28	10 ^C	15	19	28	44
14	250	0.28	<i>D</i>	11 ^C	15	23	41
	300	0.30		13	17	26	43
16	350	0.31		14	19	27	44
	250	0.30	<i>D</i>	11 ^C	15	24	41
18	300	0.32		13	17	26	43
	350	0.34		15	20	28	45
20	250	0.31	<i>D</i>	10 ^C	14	23	40
	300	0.34		13	17	26	43
24	350	0.36		15	19	28	45
	250	0.33	<i>D</i>	10	14	23	40
24	300	0.36		13	17	26	43
	350	0.38		15	19	28	44
30	200	0.33	<i>D</i>	8 ^C	12	20	37
	250	0.37		11	15	23	41
30	300	0.40		13	17	26	43
	350	0.43		15	19	28	45
36	150	0.34	<i>D</i>	...	9	17	33
	200	0.38		8 ^C	12	20	37
36	250	0.42		11	15	23	40
	300	0.45		12	16	25	42
36	350	0.49		15	19	28	44
	150	0.38	<i>D</i>	...	9	17	33
42	200	0.42		8 ^C	12	20	37
	250	0.47		10	14	23	40
42	300	0.51		12	17	25	42
	350	0.56		15	19	28	45
48	150	0.41	<i>D</i>	...	9	16	32
	200	0.47		8	12	20	37
48	250	0.52		10	14	23	40
	300	0.57		12	17	25	42
48	350	0.63		15	19	28	45
	150	0.46	<i>D</i>	...	9	17	33
54	200	0.52		8	12	20	37
	250	0.58		10	14	23	40
54	300	0.64		12	17	25	42
	350	0.70		15	19	28	44
60	150	0.51	<i>D</i>	...	9	17	33
	200	0.58		8	12	20	37
60	250	0.65		10	14	23	40
	300	0.72		13	17	25	43
60	350	0.79		15	19	28	45
	150	0.54	<i>D</i>	5 ^C	9	17	33
64	200	0.61		8	12	20	37
	250	0.68		10	14	23	40
64	300	0.76		13	17	25	43
	350	0.83		15	19	28	45
64	150	0.56	<i>D</i>	5 ^C	9	17	33
	200	0.64		8	12	20	36
64	250	0.72		10	15	23	40
	300	0.80		13	17	26	43
64	350	0.87		15	19	28	45

^A These pipes are adequate for depths of cover from 2.5 ft up to the maximum shown including an allowance for a single H-20 truck with 1.5 impact factor unless noted.

^B Calculated maximum depth of cover exceeds 100 ft.

^C Minimum allowable depth of cover is 3 ft.

^D For pipe 14 in. and larger, consideration should be given to the use of laying conditions other than Type 1.



TABLE 14 Standard Dimensions and Weights of Push-on Joint Ductile Iron Pipe

Pipe Size, in.	Pressure Class	Thickness, in.	OD, ^A in.	Weight of Barrel per ft, lb	Weight of Bell, ^B lb	18-ft Laying Length		20-ft Laying Length	
						Weight per Length, ^C lb	Average Weight per ft, ^D lb	Weight per Length, ^C lb	Average Weight per ft, ^D lb
3	350	0.25	3.96	8.9	7.0	165	9.3	185	9.2
4	350	0.25	4.80	10.9	9.0	205	11.4	225	11.3
6	350	0.25	6.90	16.0	11.0	300	16.6	330	16.5
8	350	0.25	9.05	21.1	17.0	395	22.0	440	22.0
10	350	0.26	11.10	27.1	24.0	510	28.4	565	28.3
12	350	0.28	13.20	34.8	29.0	655	36.4	725	36.3
14	250	0.28	15.30	40.4	45.0	770	42.9	855	42.7
	300	0.30	15.30	43.3	45.0	825	45.8	910	45.6
16	350	0.31	15.30	44.7	45.0	850	47.2	940	47.0
	250	0.30	17.40	49.3	54.0	940	52.3	1040	52.0
18	300	0.32	17.40	52.5	54.0	1000	55.5	1105	55.2
	350	0.34	17.40	55.8	54.0	1060	58.8	1170	58.5
20	250	0.31	19.50	57.2	59.0	1090	60.5	1205	60.2
	300	0.34	19.50	62.6	59.0	1185	65.9	1310	65.6
24	350	0.36	19.50	66.2	59.0	1250	69.5	1385	69.2
	250	0.33	21.60	67.5	74.0	1290	71.6	1425	71.2
24	300	0.36	21.60	73.5	74.0	1395	77.6	1545	77.2
	350	0.38	21.60	77.5	74.0	1470	81.6	1625	81.2
24	200	0.33	25.80	80.8	95.0	1550	86.1	1710	85.6
	250	0.37	25.80	90.5	95.0	1725	95.8	1905	95.3
30	300	0.40	25.80	97.7	95.0	1855	103.0	2050	102.5
	350	0.43	25.80	104.9	95.0	1985	110.2	2195	109.7
30	150	0.34	32.00	103.5	139.0	2000	111.2	2210	110.5
	200	0.38	32.00	115.5	139.0	2220	123.2	2450	122.5
36	250	0.42	32.00	127.5	139.0	2435	135.2	2690	134.5
	300	0.45	32.00	136.5	139.0	2595	144.2	2870	143.5
36	350	0.49	32.00	148.4	139.0	2810	156.1	3105	155.3
	150	0.38	38.30	138.5	184.0	2675	148.7	2955	147.7
42	200	0.42	38.30	152.9	184.0	2935	163.1	3240	162.1
	250	0.47	38.30	170.9	184.0	3260	181.1	3600	180.1
42	300	0.51	38.30	185.3	184.0	3520	195.5	3890	194.5
	350	0.56	38.30	203.2	184.0	3840	213.4	4250	212.4
42	150	0.41	44.50	173.8	289.0	3415	189.9	3765	188.3
	200	0.47	44.50	198.9	289.0	3870	215.0	4265	213.3
48	250	0.52	44.50	219.9	289.0	4245	236.0	4685	234.3
	300	0.57	44.50	240.7	289.0	4620	256.8	5105	255.2
48	350	0.63	44.50	265.7	289.0	5070	281.8	5605	280.2
	150	0.46	50.80	222.6	354.0	4805	240.3
54	200	0.52	50.80	251.3	354.0	5380	269.0
	250	0.58	50.80	280.0	354.0	5955	297.7
54	300	0.64	50.80	308.6	354.0	6525	326.3
	350	0.70	50.80	337.1	354.0	7095	354.8
54	150	0.51	57.56	279.7	439.0	6035	301.7
	200	0.58	57.56	317.7	439.0	6795	339.7
60	250	0.65	57.56	355.6	439.0	7550	377.5
	300	0.72	57.56	393.4	439.0	8305	415.3
60	350	0.79	57.56	431.1	439.0	9060	453.1
	150	0.54	61.61	317.0	588.0	6930	346.4
64	200	0.61	61.61	357.7	588.0	7740	387.1
	250	0.68	61.61	398.3	588.0	8555	427.7
64	300	0.76	61.61	444.6	588.0	9480	474.0
	350	0.83	61.61	485.0	588.0	10 290	514.4
64	150	0.56	65.67	350.5	670.0	7680	384.0
	200	0.64	65.67	400.1	670.0	8670	433.6
64	250	0.72	65.67	449.6	670.0	9660	483.1
	300	0.80	65.67	496.9	670.0	10 650	532.4
64	350	0.87	65.67	542.0	670.0	11 510	575.5

^A Tolerance of OD of spigot end: 3–12 in., ±0.06 in.; 14–24 in., +0.05 in., –0.08 in.; 30–48 in., +0.08 in., –0.06 in.; 54–64 in., +0.04 in., –0.10 in.

^B The bell weights shown above are adequate for 350-psi (2413-kPa) operating pressure. Bell weights vary due to differences in push-on-joint design. The manufacturer shall calculate pipe weights using standard barrel weights and weights of bells being produced.

^C Including bell; calculated weight of pipe rounded off to nearest 5 lb.

^D Including bell; average weight per foot based on calculated weight of pipe before rounding.

**NOTICE: This standard has either been superceded and replaced by a new version or discontinued.
Contact ASTM International (www.astm.org) for the latest information.**



ASTM International takes no position respecting the validity of any patent rights asserted in connection with any item mentioned in this standard. Users of this standard are expressly advised that determination of the validity of any such patent rights, and the risk of infringement of such rights, are entirely their own responsibility.

This standard is subject to revision at any time by the responsible technical committee and must be reviewed every five years and if not revised, either reapproved or withdrawn. Your comments are invited either for revision of this standard or for additional standards and should be addressed to ASTM International Headquarters. Your comments will receive careful consideration at a meeting of the responsible technical committee, which you may attend. If you feel that your comments have not received a fair hearing you should make your views known to the ASTM Committee on Standards, at the address shown below.

This standard is copyrighted by ASTM International, 100 Barr Harbor Drive, PO Box C700, West Conshohocken, PA 19428-2959, United States. Individual reprints (single or multiple copies) of this standard may be obtained by contacting ASTM at the above address or at 610-832-9585 (phone), 610-832-9555 (fax), or service@astm.org (e-mail); or through the ASTM website (www.astm.org).