



## Standard Specification for Castings, Steel and Alloy, Common Requirements, for General Industrial Use<sup>1</sup>

This standard is issued under the fixed designation A 781/A 781M; the number immediately following the designation indicates the year of original adoption or, in the case of revision, the year of last revision. A number in parentheses indicates the year of last reapproval. A superscript epsilon ( $\epsilon$ ) indicates an editorial change since the last revision or reapproval.

### 1. Scope

1.1 This specification covers a group of requirements that are mandatory requirements of the following steel casting specifications issued by ASTM. If the product specification specifies different requirements, the product specification shall prevail.

ASTM Designation	Title of Specification
A 27/A 27M	Steel Castings, Carbon, for General Application
A 128/A 128M	Steel Castings, Austenitic Manganese
A 148/A 148M	Steel Castings, High-Strength, for Structural Purposes
A 297/A 297M	Steel Castings, Iron Chromium and Iron-Chromium-Nickel, Heat Resistant for General Application
A 447/A 447M	Steel Castings, Chromium-Nickel-Iron Alloy (25-12 Class), for High-Temperature Service
A 486/A 486M	Steel Castings, for Highway Bridges
A 494/A 494M	Castings, Nickel and Nickel Alloy
A 560/A 560M	Castings, Chromium-Nickel Alloy
A 743/A 743M	Castings, Iron-Chromium, Iron-Chromium-Nickel, Corrosion Resistant, for General Application
A 744/A 744M	Castings, Iron-Chromium-Nickel, Corrosion Resistant, for Severe Service
A 747/A 747M	Steel Castings, Stainless, Precipitation Hardening
A 890/A 890M	Castings, Iron-Chromium-Nickel-Molybdenum Corrosion-Resistant, Duplex (Austenitic/Ferritic) for General Application
A 915/A 915M	Steel Castings, Carbon and Alloy, Chemical Requirements Similar to Standard Wrought Grades
A 958	Steel Castings, Carbon and Alloy, with Tensile Requirements, Chemical Requirements Similar to Standard Wrought Grades
A 1002	Castings, Nickel-Aluminum Ordered Alloy

1.2 This specification also covers a group of supplementary requirements that may be applied to the above specifications as indicated therein. These are provided for use when additional testing or inspection is desired and apply only when specified individually by the purchaser in the order.

1.3 The requirements of the individual material specification, and this general specification shall prevail in the sequence named.

1.4 The values stated in either inch-pound units or SI units are to be regarded separately as standard. Within the text, the SI units are shown in brackets. The values stated in each

system are not exact equivalents; therefore, each system must be used independently of the other. Combining values from the two systems may result in nonconformance with the specification. Inch-pound units are applicable for material ordered to Specification A 781 and SI units for material ordered to Specification A 781M.

### 2. Referenced Documents

#### 2.1 ASTM Standards:

- A 27/A27M Specification for Steel Castings, Carbon, for General Application<sup>2</sup>
- A 128/A128M Specification for Steel Castings, Austenitic Manganese<sup>2</sup>
- A 148/A148M Specification for Steel Castings, High Strength, for Structural Purposes<sup>2</sup>
- A 297/A297M Specification for Steel Castings, Iron-Chromium and Iron-Chromium-Nickel, Heat Resistant, for General Application<sup>2</sup>
- A 370 Test Methods and Definitions for Mechanical Testing of Steel Products<sup>3</sup>
- A 380 Practice for Cleaning, Descaling, and Passivation of Stainless Steel Parts, Equipment, and Systems<sup>3</sup>
- A 447/A 447M Specification for Steel Castings, Chromium-Nickel-Iron Alloy (25-12 Class), for High-Temperature Service<sup>2</sup>
- A 486/A 486M Specification for Steel Castings for Highway Bridges<sup>4</sup>
- A 488/A 488M Practice for Steel Castings, Welding, Qualifications of Procedures and Personnel<sup>2</sup>
- A 494/A 494M Specification for Castings, Nickel and Nickel Alloy<sup>2</sup>
- A 560/A 560M Specification for Castings, Chromium-Nickel Alloy<sup>2</sup>
- A 609/A 609M Practice for Castings, Carbon, Low-Alloy, and Martensitic Stainless Steel, Ultrasonic Examination Thereof<sup>2</sup>
- A 743/A 743M Specification for Castings, Iron-Chromium, Iron-Chromium-Nickel, Corrosion-Resistant, for General Application<sup>2</sup>

<sup>1</sup> This specification is under the jurisdiction of ASTM Committee A01 on Steel, Stainless Steel and Related Alloys and is the direct responsibility of Subcommittee A01.18 on Castings.

Current edition approved September 10, 2002. Published October 2002. Originally published as A 781 – 80. Last previous edition A 781/A 781M – 01a.

<sup>2</sup> Annual Book of ASTM Standards, Vol 01.02.

<sup>3</sup> Annual Book of ASTM Standards, Vol 01.03.

<sup>4</sup> Discontinued 1987. See 1986 Annual Book of ASTM Standards, Vol 01.02.

 **A 781/A 781M – 02**

- A 744/A 744M Specification for Castings, Iron-Chromium-Nickel, Corrosion Resistant, for Severe Service<sup>2</sup>
- A 747/A 747M Specification for Steel Castings, Stainless, Precipitation Hardening<sup>2</sup>
- A 751 Test Methods, Practices, and Terminology for Chemical Analysis of Steel Products<sup>3</sup>
- A 800/A 800M Practice for Steel Castings, Austenitic Alloy, Estimating Ferrite Content Thereof<sup>2</sup>
- A 802/A 802M Practice for Steel Castings, Surface Acceptance Standards, Visual Examination<sup>2</sup>
- A 890/A 890M Specification for Castings, Iron-Chromium-Nickel-Molybdenum Corrosion-Resistant, Duplex (Austenitic/Ferritic) for General Application<sup>2</sup>
- A 915/A 915M Specification for Steel Castings, Carbon and Alloy, Chemical Requirements Similar to Standard Wrought Grades<sup>2</sup>
- A 941 Terminology Relating to Steel, Stainless Steel, Related Alloys, and Ferroalloys<sup>5</sup>
- A 958 Specification for Steel Castings, Carbon and Alloy, with Tensile Requirements, Chemical Requirements Similar to Standard Wrought Grades<sup>2</sup>
- A 967 Specification for Chemical Passivation Treatments for Stainless Steel Parts<sup>3</sup>
- A 991/A 991M Test Method for Conducting Temperature Uniformity Surveys of Furnaces Used to Heat Treat Steel Products<sup>3</sup>
- A 1002 Specification for Castings, Nickel-Aluminum Ordered Alloy<sup>2</sup>
- E 94 Guide for Radiographic Examination<sup>6</sup>
- E 125 Reference Photographs for Magnetic Particle Indications on Ferrous Castings<sup>6</sup>
- E 165 Test Method for Liquid Penetrant Examination<sup>6</sup>
- E 186 Reference Radiographs for Heavy-Walled (2 to 4½-in. (51 to 114-mm)) Steel Castings<sup>6</sup>
- E 280 Reference Radiographs for Heavy-Walled (4½ to 12-in. (114 to 305-mm)) Steel Castings<sup>6</sup>
- E 340 Test Method for Macroetching Metals and Alloys<sup>7</sup>
- E 353 Test Methods for Chemical Analysis of Stainless, Heat-Resisting, Maraging, and Other Similar Chromium-Nickel-Iron Alloys<sup>8</sup>
- E 354 Test Methods for Chemical Analysis of High-Temperature, Electrical, Magnetic, and Other Similar Iron, Nickel, and Cobalt Alloys<sup>8</sup>
- E 446 Reference Radiographs for Steel Castings Up to 2 in. (51 mm) in Thickness<sup>6</sup>
- E 709 Guide for Magnetic Particle Examination<sup>6</sup>

### 3. Terminology

#### 3.1 Definitions:

3.1.1 The definitions in Test Methods and Definitions A 370, Test Methods, Practices, and Terminology A 751, and Terminology A 941 are applicable to this specification and those listed in 1.1.

### 4. Materials and Manufacture

4.1 *Melting Process*—The steel shall be made by open-hearth or electric furnace process with or without separate refining such as argon-oxygen-decarburization (AOD) unless otherwise specified in the individual specification.

### 5. Chemical Composition

5.1 *Chemical Analysis*—Chemical analysis of materials covered by this specification shall be in accordance with Test Methods, Practices, and Terminology A 751.

5.2 *Heat Analysis*—An analysis of each heat shall be made by the manufacturer to determine the percentages of the elements specified in the individual specification for the grade being poured. The analysis shall be made from a test sample preferably taken during the pouring of the heat. When drillings are used, they shall be taken not less than ¼ in. [6.4 mm] beneath the surface. The chemical composition thus determined shall conform to the requirements in the individual specification for the grade being poured.

5.3 *Product Analysis*—A product analysis may be made by the purchaser from material representing each heat, lot, or casting. The analysis shall be made on representative material. Samples for carbon analysis of carbon and alloy steel shall be taken no closer than ¼ in. to a cast surface, except that castings too thin for this shall be analyzed on representative material. The chemical composition thus determined shall meet the requirements specified in the applicable specification for the grade involved, or shall be subject to rejection by the purchaser, except that the chemical composition determined for carbon and low alloy steel castings may vary from the specified limits by the amounts shown in Table 1. The product analysis tolerances of Table 1 are not applicable as acceptance criteria for heat analysis by the casting manufacturer. When comparing product and heat analysis for other than carbon and low alloy steels, the reproducibility Data  $R_2$ , in Test Methods E 353 or E 354, as applicable, shall be taken into consideration.

5.4 *Unspecified Elements*—When chemical analysis for elements not specified for the grade ordered is desired, Supplementary Requirement S13 may be specified.

5.4.1 Grade substitution, for stainless steel or nickel base alloy castings, is not permitted. Grade substitution occurs when the material supplied:

- (1) contains an element, other than nitrogen, that is not specified in the ordered grade; and,
- (2) the amount of that element equals or exceeds the minimum requirement for the element in another grade for which it is specified.

For this requirement, a grade is defined as an alloy described individually in a table of chemical requirements within any specification listed within the scope of A 781/A 781M.

### 6. Tensile Requirements

6.1 The individual product specifications vary as to whether tension tests are required; for this reason, and to determine specific test requirements, the individual product specification should be reviewed.

6.2 Unless otherwise specified by the purchaser, when mechanical properties are required by the product specification, test coupons may be cast integrally with the castings, or

<sup>5</sup> Annual Book of ASTM Standards, Vol 01.01.

<sup>6</sup> Annual Book of ASTM Standards, Vol 03.03.

<sup>7</sup> Annual Book of ASTM Standards, Vol 03.01.

<sup>8</sup> Annual Book of ASTM Standards, Vol 03.05.

**TABLE 1 Product Analysis Tolerances**

Element	Range, % <sup>A</sup>	Tolerances <sup>B, C</sup> Over Maximum or Under Minimum Limit, %
C	up to 0.65 above 0.65	$0.03 \times \% C_L + 0.02$ 0.04
Mn	up to 1 above 1	$0.08 \times \% Mn_L + 0.01$ 0.09
Si	up to 0.60 above 0.60	$0.22 \times \% Si_L - 0.01$ 0.15
P	all	$0.13 \times \% P_L + 0.005$
S	all	$0.36 \times \% S_L + 0.001$
Ni	up to 2 above 2	$0.10 \times \% Ni_L + 0.03$ 0.25
Cr	up to 2 above 2	$0.07 \times \% Cr_L + 0.04$ 0.18
Mo	up to 0.6 above 0.6	$0.04 \times \% Mo_L + 0.03$ 0.06
V	up to 0.25 above 0.25	$0.23 \times \% V_L + 0.004$ 0.06
W	up to 0.10 above 0.10	$0.08 \times \% W_L + 0.02$ 0.02
Cu	up to 0.15 above 0.15	$0.18 \times \% Cu_L + 0.02$ 0.05
Al	up to 0.10 above 0.10	$0.08 \times \% Al_L + 0.02$ 0.03

<sup>A</sup> The range denotes the composition limits up to which tolerances are computed by the equation, and above which the tolerances are given by a constant.

<sup>B</sup> The subscript <sub>L</sub> for the elements in each equation indicates that the limits of the element specified by the applicable specification are to be inserted into the equation to calculate the tolerance for the upper limit and the lower limit (if applicable), respectively. Examples of computing tolerances are presented in footnote C.

<sup>C</sup> To illustrate the computation of the tolerance, consider the manganese maximum of 0.70 for an 0.30 carbon grade 65–35 in Specification A 27/A 27M. The maximum permissible deviation is  $(0.08 \times 0.70 + 0.01) = 0.066$ . Therefore, the highest acceptable product analysis is 0.766. Similarly, for an 0.20 carbon grade 70–40 in Specification A 27/A 27M, the maximum manganese content is 1.40; thus, the highest acceptable product analysis is  $(1.40 + 0.09) = 1.49$ .

as separate blocks, in accordance with Fig. 1, Fig. 2, or Fig. 3 except when Supplementary Requirement S15 is specified. The test coupon in Fig. 3 shall be employed only for austenitic alloy castings with cross sections less than 2½ in.<sup>9</sup>

## 7. Workmanship, Finish, and Appearance

7.1 All castings shall be made in a workmanlike manner and

<sup>9</sup> Information on the relationship of mechanical properties determined on test coupons obtained as specified in 6.2 with those obtained from the casting may be found in "The Steel Casting Handbook," Fifth Edition, Steel Founders' Society of America, pp. 15–35 through 15–43, 1980.

shall conform to the dimensions on drawings furnished by the purchaser before manufacture is started. If the pattern is supplied by the purchaser, the dimensions of the casting shall be as predicated by the pattern.

## 8. Quality

8.1 The surface of the casting shall be free of adhering sand, scale, cracks, and hot tears as determined by visual examination. Other surface discontinuities shall meet the visual acceptance standards specified in the order. Practice A 802/A 802M or other visual standards may be used to define acceptable surface discontinuities and finish. Unacceptable visual surface discontinuities shall be removed and their removal verified by visual examination of the resultant cavities.

8.2 When additional inspection is desired, Supplementary Requirements S1, S2, S3, S4, or S5 may be specified.

## 9. Repair

9.1 Repair by welding shall be in accordance with the requirements of the individual specification using procedures and welders qualified in accordance with Practice A 488/A 488M.

## 10. Inspection

10.1 The manufacturer shall afford the purchaser's inspector all reasonable facilities necessary to satisfy that the material is being produced and furnished in accordance with the applicable specification. Foundry inspection by the purchaser shall not interfere unnecessarily with the manufacturer's operations. All tests and inspections, with the exception of product analysis (5.3), shall be made at the place of manufacture unless otherwise agreed.

## 11. Rejection

11.1 Subsequent to acceptance at the manufacturer's works, material which is found to be unacceptable as determined by requirements specified in the order may be rejected by the purchaser. The manufacturer should be notified of such rejection. If the manufacturer is dissatisfied with the results of any tests performed by the purchaser, he may make claim for a rehearing.

## 12. Keywords

12.1 castings; common requirements; steel and alloy

**ASTM A 781/A 781M – 02**

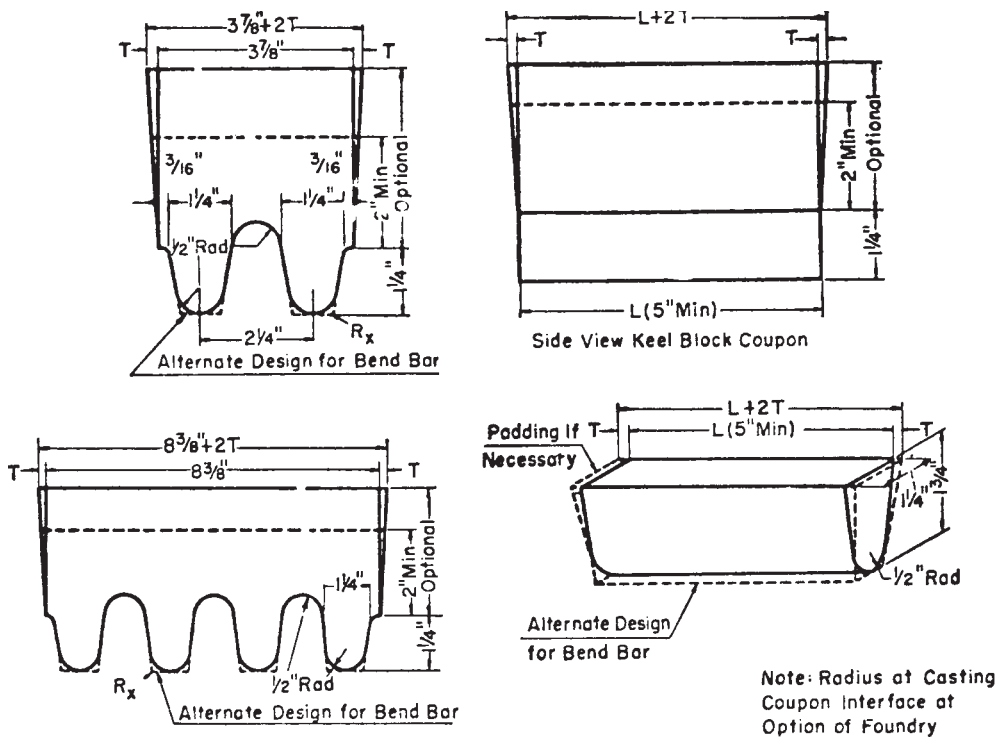

Metric Equivalents

in.	3/16	1/2	1 1/4	1 3/4	2	2 1/4	3 7/8	5	8 3/8
[mm]	[4.8]	[13]	[32]	[45]	[51]	[57]	[98]	[127]	[213]

Leg Design [125 mm]

1. *L* (length) A 5 in. [125 mm] minimum length will be used. This length may be increased at the option of the foundry to accommodate additional test bars (see Note 1).
2. End Taper Use of and size of end taper is at the option of the foundry.
3. Height 1 1/4 in. [32 mm]
4. Width (at top) 1 1/4 [32 mm] (see Note 1).
5. Radius (at bottom) 1/2 in. [13 mm], max
6. Spacing between legs A 1/2-in. [13-mm] radius will be used between the legs.
7. Location of test bars The tensile, bend, and impact bars will be taken from the lower portion of the leg (see Note 2).
8. Number of legs The number of legs attached to the coupon is at the option of the foundry providing they are equi-spaced according to Item 6.
9. *R<sub>s</sub>* Radius from 0 to approximately 1/16 in. [2 mm].

Riser Design

1. *L* (length) The length of the riser at the base will be the same as the top length of the leg. The length of the riser at the top therefore depends on the amount of taper added to the riser.
2. Width The width of the riser at the base of a multiple-leg coupon shall be  $n(2\frac{1}{4}) [57 \text{ mm}] - \frac{5}{8} [16 \text{ mm}]$  where *n* equals the number of legs attached to the coupon. The width of the riser at the top is therefore dependent on the amount of taper added to the riser.
3. *T*(riser taper) Use of and size is at the option of the foundry. The minimum height of the riser shall be 2 in. [51 mm]. The maximum height is at the option of the foundry for the following reasons: (a) many risers are cast open. (b) different compositions may require variation in risering for soundness. (c) different pouring temperatures may require variation in risering for soundness.

NOTE 1—*Test Coupons for Large and Heavy Steel Castings*: The test coupons in Fig. 1 are to be used for large and heavy steel castings. However, at the option of the foundry the cross-sectional area and length of the standard coupon may be increased as desired.

NOTE 2—*Bend Bar*: If a bend bar is required, an alternate design (as shown by dotted lines in Fig. 1) is indicated.

**FIG. 1 Test Coupons for Castings with Details of Design**

**ASTM A 781/A 781M - 02**

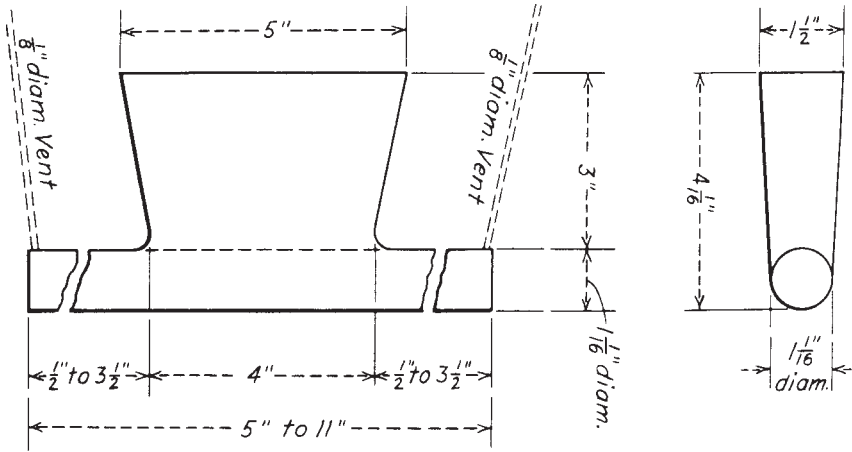

**Metric Equivalents**

in.	[mm]	in.	[mm]
1/8	[3.2]	3 1/2	[88.9]
1/2	[12.7]	4	[101.6]
1 1/16	[27.0]	4 1/16	[103.2]
1 1/2	[38.1]	5	[127.0]
3	[76.2]	11	[279.4]

NOTE—Pour through head; cover molten head with powdered charcoal, coke dust, and so forth, immediately after pouring, in order to keep head fluid as long as possible.

**FIG. 2 Test Block for Tension Test Specimen**

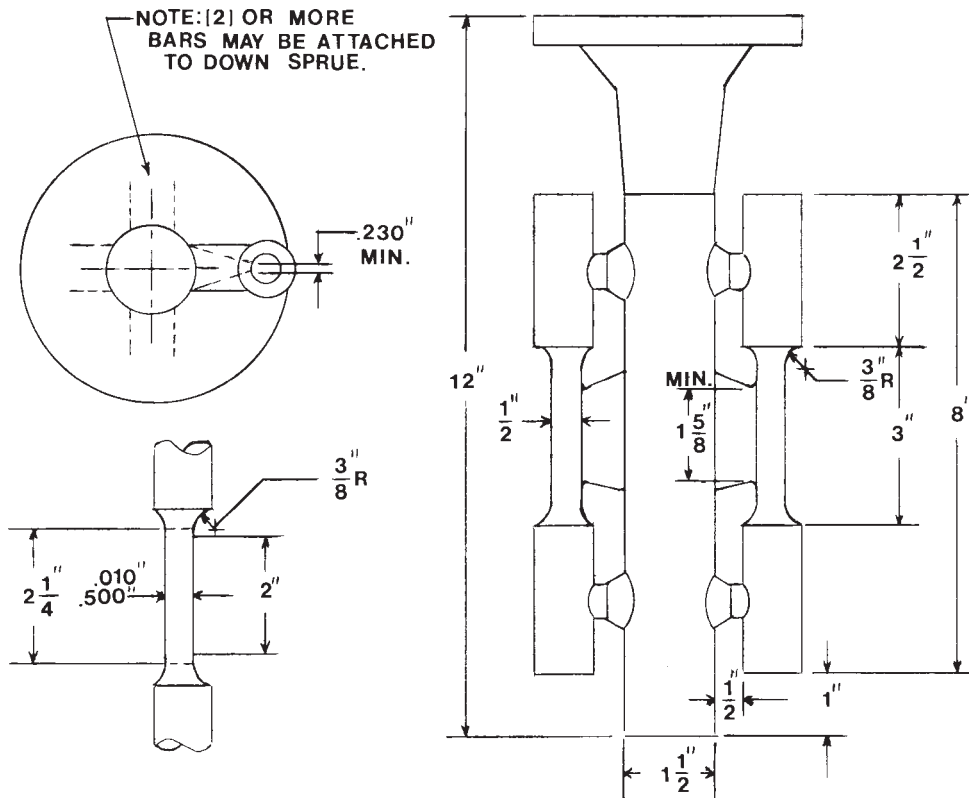

NOTE—Coupons produced in this manner are suitable for austenitic alloys only. The mold may be preheated for pouring to produce a sound coupon.

**FIG. 3 Cast-To-Shape Test Coupon for Tension Specimen**



## SUPPLEMENTARY REQUIREMENTS

Supplementary requirements shall be applied only when specified by the purchaser. Details of the supplementary requirements shall be agreed upon by the manufacturer and purchaser. The specified tests shall be performed by the manufacturer prior to shipment of the castings.

### S1. Magnetic Particle Examination

S1.1 Castings shall be examined for surface and near surface discontinuities by magnetic particle examination. The examination shall be in accordance with Guide E 709. Extent of examination and the basis for acceptance shall be agreed upon between the manufacturer and purchaser.

### S2. Radiographic Examination

S2.1 Castings shall be examined for internal defects by means of X rays or gamma rays. The procedure shall be in accordance with Guide E 94, and types and degrees of discontinuities considered shall be judged by Reference Radiographs E 446, E 186, or E 280. Extent of examination and basis for acceptance shall be agreed upon between the manufacturer and purchaser.

### S3. Liquid Penetrant Examination

S3.1 Castings shall be examined for surface discontinuities by means of liquid penetrant examination. The examination shall be in accordance with Test Method E 165. Areas to be inspected, methods and types of liquid penetrants to be used, developing procedure, and basis for acceptance shall be agreed upon between the manufacturer and purchaser.

### S4. Ultrasonic Examination

S4.1 Castings shall be examined for internal defects by means of ultrasonic examination. The examination procedure shall be in accordance with Practice A 609/A 609M. Extent of examination, methods of testing, and basis for acceptance shall be agreed upon between the manufacturer and purchaser.

### S5. Examination of Weld Preparation

S5.1 Magnetic particle or liquid penetrant examination of cavities prepared for welding shall be performed to verify removal of those discontinuities found unacceptable by the examination method specified for the casting. Unless other degrees of shrinkage or types of discontinuities found in the cavities are specified, Type II, Internal Shrinkage, of Reference Photographs E 125, of Degree 2 in sections up to 2 in. [50.8 mm] thick and of Degree 3 in sections over 2 in. thick shall be acceptable.

### S6. Certification

S6.1 The manufacturer's certification shall be furnished to the purchaser stating that the material was manufactured, sampled, tested, and inspected in accordance with the material specification (including year date) and was found to meet the requirements.

S6.2 A manufacturer's certification printed from or used in electronic form from an electronic data interchange (EDI) transmission shall be regarded as having the same validity as a

counterpart printed in the certifier's facility provided it conforms to any existing EDI agreement between the purchaser and the supplier.

### S7. Prior Approval of Major Weld Repairs

S7.1 Major weld repairs as defined and agreed upon between the manufacturer and purchaser shall be subject to the prior approval of the purchaser.

### S8. Marking

S8.1 The manufacturer's name or identification mark and the pattern number shall be cast or stamped on all castings. When further specified, the heat numbers or serial numbers shall be marked on individual castings.

### S9. Charpy Impact Test

S9.1 Charpy impact test properties shall be determined on each heat from a set of three Charpy V-notch specimens made from a test coupon in accordance with Test Methods and Definitions A 370, and tested at a test temperature agreed upon by the manufacturer and purchaser. The acceptance requirements shall be either energy absorbed, lateral expansion, or percent shear area, or all three, and shall be that agreed upon between the manufacturer and purchaser. Test specimens shall be prepared as Type A and tested in accordance with Test Methods and Definitions A 370.

S9.2 *Absorbed Energy*—Average energy value of three specimens shall be not less than specified, with not more than one value permitted to fall below the minimum specified and no value permitted below the minimum specified for a single specimen.

S9.3 *Lateral Expansion*—Lateral expansion value shall be agreed upon between the manufacturer and purchaser.

S9.4 *Percent Shear Area*—Percent shear area shall be agreed upon between the manufacturer and purchaser.

### S10. Hardness Test

S10.1 Hardness measurements at specified locations of the castings shall be made in accordance with Test Methods and Definitions A 370 and reported.

### S11. Specified Ferrite Content Range

S11.1 The chemical composition of the heat shall be controlled such that the ferrite content, as determined by the chemical composition procedure of Practice A 800/A 800M, shall be in conformance with the specified ferrite content range.

S11.2 The specified ferrite content range shall be as agreed upon between the manufacturer and the purchaser. The minimum specified ferrite content range shall be 10 % with the minimum ferrite content being no lower than the percent

necessary to achieve the minimum mechanical properties required for the alloy.

S11.3 Should the purchaser wish to have the ferrite content determined by either magnetic response or metallographic methods, the purchaser should impose Supplementary Requirement S1 or S2 of Practice A 800/A 800M.

**S12. Test Report**

S12.1 The manufacturer shall supply a test report to the purchaser giving the results of all tests performed including chemical analysis.

**S13. Unspecified Elements**

S13.1 Chemical analysis and limits for elements not specified for the grade ordered shall be as agreed upon between the manufacturer and purchaser.

**S14. Tension Test from Castings**

S14.1 In addition to the tension test required by the material specification, test material shall be cut from the casting. The mechanical properties and location for the test material shall be agreed upon by the manufacturer and purchaser.

**S15. Alternate Tension Test Coupons and Specimen Locations for Castings (in lieu of Test Bars Poured from Special Blocks)**

S15.1 Test blocks may be cast integrally with the castings or as separate blocks. Test blocks shall be heat-treated together with the castings they represent.

S15.2 In the following, the casting thickness,  $T$ , is the maximum thickness of the casting exclusive of padding added for directional solidification, flanges, appendages, and sections designated by the designer as noncritical. The order, inquiry, and drawing shall designate what the test dimension,  $T$ , is for the casting.

S15.3 One of the following shall apply:

S15.3.1 The longitudinal centerline of the test specimen shall be taken at least  $\frac{1}{4} T$  from the  $T$  dimension surface and all of the gage length must be at least  $1T$  from any other heat treated surface, exclusive of the surface opposite the  $T$  dimension surface. (See Fig. 4 (a).) For cylindrical castings, the longitudinal centerline of the specimens shall be taken at least  $\frac{1}{4} T$  from the outside or inside and all of the gage length must be at least  $T$  from the as-heat-treated end. (See Fig. 4 (b).) For ferritic and martensitic castings, partial severing of test blocks

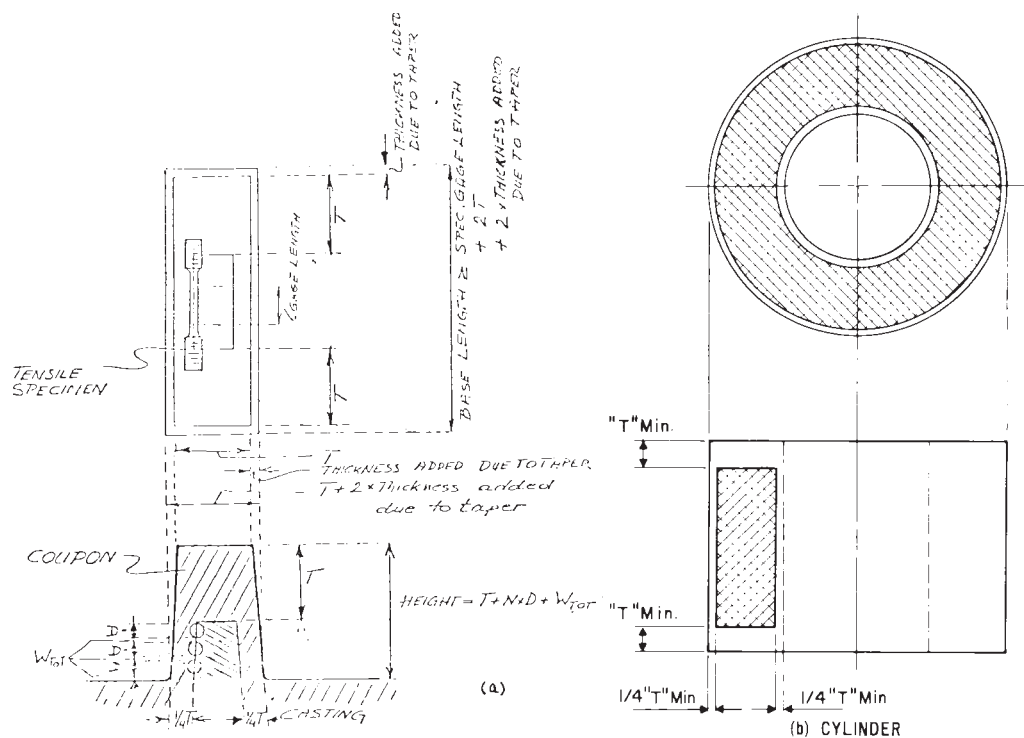

Minimum length of the base—Specimen gage length +  $2xT$  +  $2x$  the thickness due to the tapes. \

Minimum width of the base— $T$  +  $2x$  the thickness added due to the tapes. \

Minimum height —  $T + NxD + W_{tot}$  \

The taper is to be selected by the producer for ease of drawing the pattern from the mold.

where:

$N$  = number of specimens to be cut from one side of the coupon,

$D$  = diameter of the specimens, and

$W_{tot}$  = the total width of metal required to remove the coupon from the casting, and to machine specimens from the coupon.

NOTE—Longitudinal axis and gage length of test specimen must be within shaded zone.

**FIG. 4 Specimen from Casting**

prior to final heat treatment is permitted.

S15.3.2 Where separately cast test coupons are used, the dimension shall not be less than  $3T$  by  $3T$  by  $T$  and each specimen shall meet the requirements of S15.3.1, except that when  $T$  exceeds 5 in. [125 mm], the dimension may be 15 by 15 by 5 in. [375 by 375 by 125 mm], by agreement between the manufacturer and the purchaser. The test coupon shall be of the same heat of steel and shall receive substantially the same casting practices as the production casting it represents. Centrifugal castings may be represented by statically cast coupons. (See Fig. 5.)

S15.3.3 When agreed upon by the manufacturer and the purchaser, castings that are cast or machined to essentially the finished configuration prior to heat-treatment shall have test specimens removed from a prolongation or other stock on the casting at a location below the nearest heat-treated surface indicated on the order. The specimen location shall be at a distance below the nearest heat-treated surface equivalent to at least the greatest distance that the indicated high-tensile-stress surface will be from the nearest heat-treated surface and a minimum of twice this distance from a second heat-treated surface, except that the test specimens shall be no nearer than  $\frac{3}{4}$  in. [19 mm] to a heat-treated surface and  $1\frac{1}{2}$  in. [38 mm] from a second heat-treated surface. (See Fig. 6.)

S15.3.4 Where specimens are to be removed from the body of quenched and tempered castings, either the requirements of S15.3.1 shall be met or a steel thermal buffer pad or thermal insulation or other thermal barriers shall be used during heat-treatment. Steel thermal buffer pads shall be a minimum of  $T$  by  $T$  by  $3T$  in length and shall be joined to the casting surface by a partial penetration weld completely sealing the buffered surface. Test specimens shall be removed from the

casting in a location adjacent to the center third of the buffer pad. They shall be located at a minimum distance of  $\frac{1}{2}$  in. [13 mm] from the buffered surface and  $\frac{1}{4} T$  from other heat-treated surfaces (see Fig. 7). When thermal insulation is used, it shall be applied adjacent to the casting surface where the test specimens are to be removed. The producer shall demonstrate that the cooling rate of the test specimen location is no faster than that of specimens taken by the method described in S15.3.1.

### S16. Weld Repair Charts

S16.1 Major weld repairs shall be documented by means of sketches or photographs, or both, showing the location and major dimensions of cavities prepared for welding. Documentation shall be submitted to the purchaser at the completion of the order.

S16.2 A weld repair shall be considered major when it is made to correct leakage on hydrostatic testing, or when the depth of the cavity prepared for welding exceeds 20 % of the actual wall thickness or 1 in. [25 mm], whichever is smaller, or when the extent of the cavity exceeds approximately 10 in.<sup>2</sup> [65 cm<sup>2</sup>].

### S17. Macroetch Test

S17.1 Apply Supplementary Requirement S13 for the spectrographic determination and reporting of the total residual aluminum content of all heats of ferritic and martensitic steels subjected to this macroetch test.

S17.2 When the heat analysis indicates a total residual aluminum content in excess of 0.08 %, the manufacturer shall etch a cross section of the casting with the heaviest section for which this supplementary requirement is invoked, or a coupon

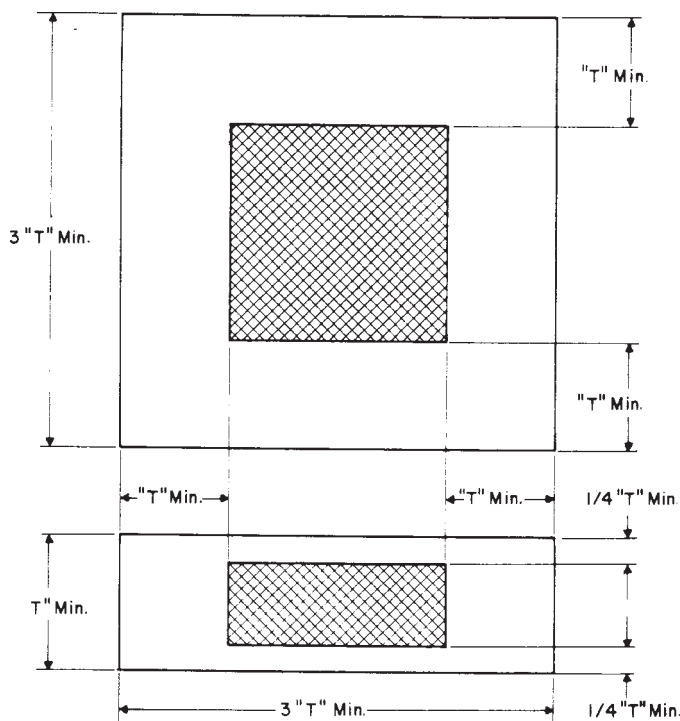

NOTE—Longitudinal axis and gage length of test specimen must be within cross-hatched zone.

**FIG. 5 Separately Cast Block**



**ASTM A 781/A 781M - 02**

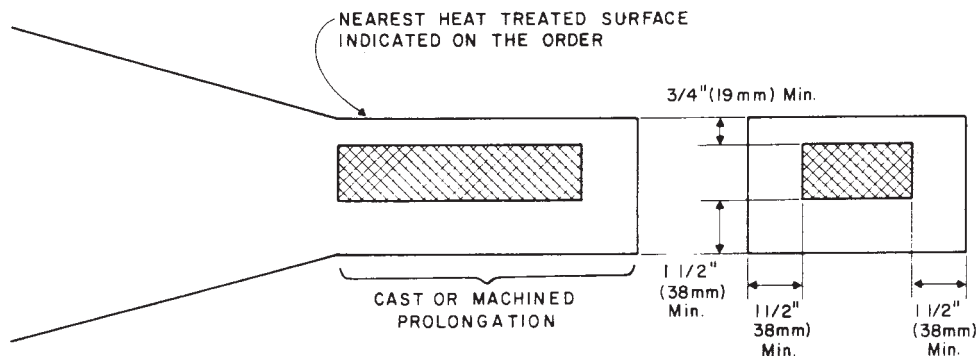

NOTE—Longitudinal axis and gage length of test specimen must be within cross-hatched zone.

**FIG. 6 Prolongation Test Specimen**

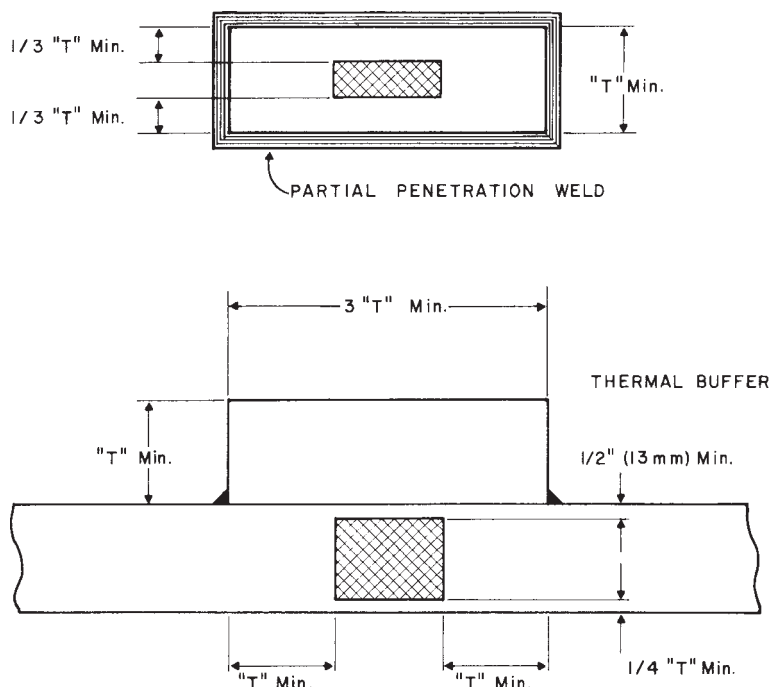

NOTE—Longitudinal axis and gage length of test specimen must be within cross-hatched zone.

**FIG. 7 Thermal Buffer Pad**

attached to that heaviest section or an area directly under a riser (see Note S17.1). Cross sections from a separately cast test block from the same heat and of a thickness representative of the heaviest section of castings purchased under this supplementary requirement may also be used for macroetch testing. The etching shall be performed on the selected section after its heat treatment, that is, after annealing, normalizing, or quenching and tempering following the initial cooling of the steel below the transformation range.

Note S17.1—High strength martensitic castings, in particular, may be damaged beyond use if the etch is applied directly to the casting.

S17.3 The preparation of the surface and the macroetching procedure with Solution No. 1 (1:1 HCl) of Table 5 in Test Method E 340 shall be followed. The resulting etched surface shall be compared and rated with the reference photographs in Fig. 8 depicting ten levels of severity of intergranular network structures indicative of the presence of aluminum nitride or

other constituents prone toward precipitating at grain boundaries during solidification and subsequent cooling. Table S17.1 relates the severity levels shown in these photographs with specific delineation widths and percent of boundary outlining in the etched structures.

S17.4 Castings represented by etched structures exhibiting a network rating in excess of Severity Level 4 shall be considered unacceptable until further evaluations are completed. The acceptability of individual castings may be determined by etching sections of each casting to ascertain the network severity level. Disposition of unacceptable castings shall be a matter of agreement between the manufacturer and purchaser. Those castings exhibiting etched severity levels greater than four may be evaluated further by any of the following agreed-upon methods:

S17.4.1 Fracture testing to determine the amount of “rock candy” structure.

S17.4.2 Mechanical testing (for example, bend, tensile) to

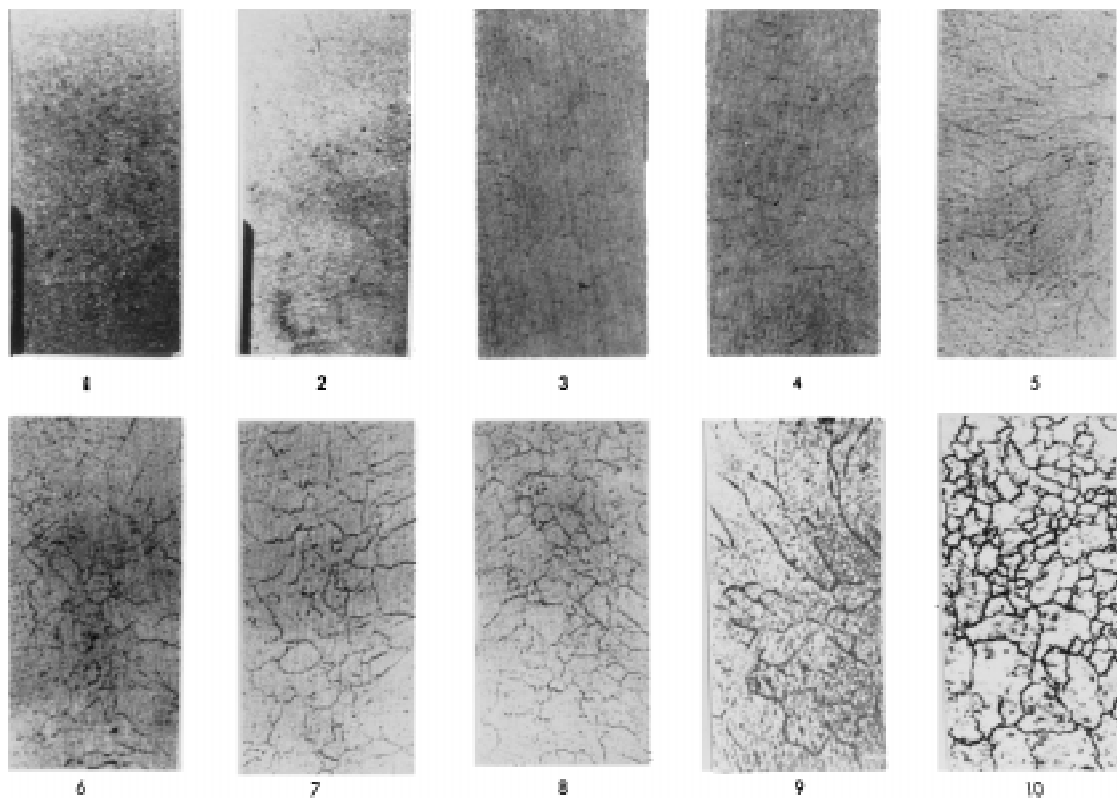

NOTE—The ten levels of severity of intergranular network structures shown are indicative of the presence of aluminum nitride precipitation in the primary austenitic grain boundaries.

**FIG. 8 Reference Photographs of Macroetched Cast Steel**

determine the ductility characteristics.

S17.4.3 Weld testing to determine crack susceptibility in the heat-affected zone of a circular groove welded with cellulose-coated electrodes.

S17.5 Alternatively, by agreement, it is permissible to subject castings from an unacceptable heat to a high temperature solution treatment prior to the normal production heat-treatment and subsequently macroetch test each casting.

S17.6 Heavy section castings (see Note S17.2) whose configurations are amenable to the attachment of test coupons representative of the section thickness involved and from which standard 0.505 in. [12.827 mm] diameter tension specimens may be machined are exempt from this macroetch test if the results of the tension test on the coupon after heat-treatment of the casting meet the minimum requirements specified for the grade of steel involved.

Note S17.2—For purposes of this supplementary requirement, a heavy section casting is defined as one having a wall thickness of 1½ in. [37 mm] or greater, in combination with a casting weight of at least 1000 lb [455 kg].

### **S18. Hot Isostatic Pressing (HIPing)**

S18.1 Castings shall be processed by Hot Isostatic Pressing (HIPing). The processing parameters for the HIPing process

may be subject to an agreement between the manufacturer and purchaser.

### **S19. Cleaning of Stainless Steels**

S19.1 Final cleaning of the casting surfaces shall be performed in accordance with one of the cleaning methods in Practice A 380 or Specification A 967 as agreed upon between the purchaser and the supplier. Acceptance testing shall be subject to agreement between the purchaser and supplier.

### **S20. Heat Treatment in the Working Zone of a Surveyed Furnace**

S20.1 Castings shall be heat treated in the working zone of a furnace that has been surveyed in accordance with Test Method A 991/A 991M.

S20.2 When castings are heat treated at temperatures above 2000°F [1100°C], then the working zone shall have been established by a survey performed at not more than 25°F [15°C] below nor more than 200°F [110°C] above the minimum heat treatment temperature specified for the grade. If the minimum heat treatment temperature is not specified for the grade, then the survey temperature shall be not more than 50°F [30°C] below nor more than 175°F [100°C] above the furnace set point used.

**ASTM A 781/A 781M – 02**

**APPENDIXES**

**(Nonmandatory Information)**

**X1. ALLOY DESIGNATIONS FOR CAST STAINLESS STEELS**

X1.1 Cast stainless steels are usually specified on the basis of composition using the alloy designation system established by the Alloy Casting Institute (ACI). The ACI designations, for example, CF8M, have been adopted by ASTM and are preferred for cast alloys over the designations used by the American Iron and Steel Institute for similar wrought steels.

X1.2 This nomenclature system has served successfully to accommodate changes in old alloys and to designate new ones.

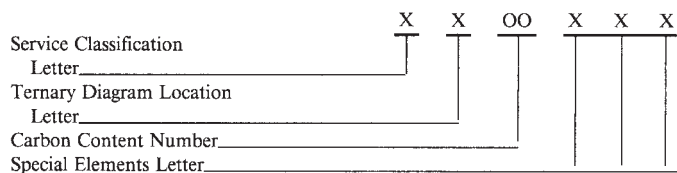

**X1.2.1 Service Classification Letter**

The first letter of the cast stainless steel designation system identifies the intended service application of the alloy. The letter C indicates corrosion-resistant service, and the letter H indicates the heat-resistant service at and above 1200°F [649°C].

**X1.2.2 Ternary Diagram Location Letter**

The second letter indicates the approximate location of the nickel and chromium contents of the alloy grade on the FeCrNi ternary diagram shown in Fig. X1.1.

**X1.2.3 Carbon Content Number**

For C service classifications, this single or dual digit numeral represents the maximum carbon content in units of 0.01 %. For H service classifications, this number represents the midpoint of the range of carbon content in terms of 0.01 % with a ±0.05 % limit.

**X1.2.4 Special Elements Letter**

Additional letters following the numeral represent special chemical elements in the alloy grade, such as M for molybdenum, C for columbium, Cu for copper, W for tungsten. There are two exceptions; the letter A indicates Controlled Ferrite, and the letter F indicates Free Machining.

X1.3 In Fig. X1.1, unlettered Ni-Cr ranges are associated with the nearest lettered location. They may be the result of differences between corrosion and heat-resistant types, or because of the influence of additional elements, for example, the precipitation hardening grade CB-7Cu-1 and CB-7Cu-2.

**ASTM A 781/A 781M – 02**

LOCATION OF ACI ALLOY TYPES

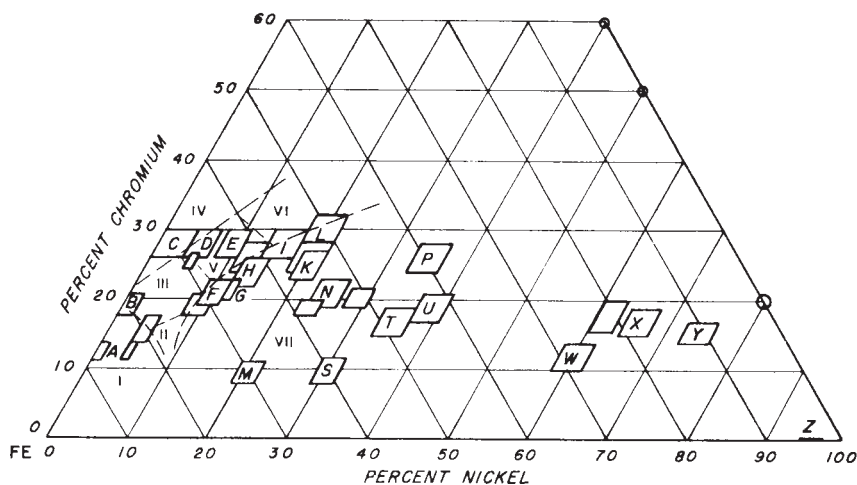

NOTE 1—The approximate areas of microstructures to be expected at room temperature are indicated as follows:

- I—Martensite
- II—Martensite and untransformed austenite
- III—Ferrite plus martensite and untransformed austenite
- IV—Ferrite
- V—Ferrite plus austenite
- VI—Ferrite plus austenite plus sigma
- VII—Austenite

NOTE 2—Carbides also may be present depending on carbon content and thermal history.

**FIG. X1.1 Letters Assigned to Chromium and Nickel Ranges in ACI Designation System**

**X2. WROUGHT ALLOYS SIMILAR TO CASTING ALLOYS IN SPECIFICATIONS  
A 494, A 743, A 744, A 747 AND A 890**

X2.1 Table X2.1 is provided for the user of the above listed specifications as an aid in selecting cast alloys which are similar in chemical composition to wrought alloys. It is not

intended to imply that the cast alloy would have the same mechanical, physical or corrosion properties as the indicated wrought alloy.

**TABLE X2.1 Similar Alloys**

Nominal Composition	ASTM Casting Specification	Casting Grade Designation	UNS Number	Similar Wrought Alloy	UNS Number
11Cr-7Ni	A 743	CA-6N	J91650	...	...
13Cr-4Ni	A 743	CA-6NM	J91540	F-6NM <sup>A</sup>	S41500
13Cr	A 743	CA-15	J91150	410 <sup>B</sup>	S41000
13Cr	A 743	CA-40	J91151	...	...
12Cr-Mo-V-W	A 743	CA28MWV	J91422	422 <sup>B</sup>	S42200
13Cr-Mo	A 743	CA15M	J91153	420 <sup>B</sup>	S42000
13Cr-S	A 743	CA-40F	J91154	420F <sup>B</sup>	S42020
19Cr-1Ni	A 743	CB-30	J91803	442 <sup>B</sup>	S44200
16Cr-4Ni-4Cu	A 747	CB7Cu-1	J92180	17-4 <sup>C</sup>	S17400
15Cr-5Ni-3Cu	A 747	CB7Cu-2	J92110	15-5 <sup>C</sup>	S15500
27Cr	A 743	CC-50	J92615	446 <sup>B</sup>	S44600
25Cr-5Ni-3Cu-2Mo	A 743, A 744, A 890	1A & CD-4MCu	J93370	255 <sup>C</sup>	S32550
24Cr-10Ni-3Mo-N	A 890	2A & CE-8MN	J93345	...	...
25Cr-5Ni-2Mo-N	A 890	3A & CD6MN	J93371	...	...
22Cr-5Ni-3Mo-N	A 890	4A & CD3MN	J92205	2205 <sup>C</sup>	S39205
25Cr-7Ni-4Mo-N	A 890	5A & CE3MN	J93404	...	...
28Cr-9Ni	A 743	CE-30	J93423	...	...
18Cr-8Ni	A 743, A 744	CF-3	J92500	304L <sup>B</sup>	S30403
16Cr-12Ni-2Mo	A 743, A 744	CF-3M	J92800	316L <sup>B</sup>	S31603
16Cr-12Ni-2Mo-N	A 743	CF-3MN	J92804	316LN <sup>B</sup>	S31653
18Cr-8Ni	A 743, A 744	CF-8	J92600	304 <sup>B</sup>	S30400
18Cr-10Ni-Cb	A 743, A 744	CF-8C	J92710	347 <sup>B</sup>	S34700
16Cr-12Ni-2Mo	A 743, A 744	CF-8M	J92900	316 <sup>B</sup>	S31600

 **A 781/A 781M – 02**

Nominal Composition	ASTM Casting Specification	Casting Grade Designation	UNS Number	Similar Wrought Alloy	UNS Number
18Cr-8Ni-4Si-N	A 743	CF-10SMnN	J92972	Nitronic 60 <sup>D</sup>	S21800
18Cr-8Ni-S	A 743	CF-16F	J92701	303Se <sup>B</sup>	S30300
18Cr-8Ni	A 743	CF-20	J92602	302 <sup>B</sup>	S30200
22Cr-13Ni-5Mn	A 743	CG-6MMN	J93790	Nitronic 50 <sup>D</sup>	S20910
18Cr-13Ni-3Mo	A 743, A 744	CG-8M	J93000	317 <sup>B</sup>	S31700
21Cr-11Ni	A 743	CG-12	J93001	308 <sup>B</sup>	S30800
23Cr-12Ni	A 743	CH-20	J93402	309 <sup>B</sup>	S30900
20Cr-18Ni-6Mo-Cu-N	A 743, A 744	CK-3MCuN	J93254	254 SMO <sup>E</sup>	S31254
25Cr-20Ni	A 743	CK-20	J94202	310 <sup>B</sup>	S31000
24Ni-21Cr-6Mo-N	A 743, A 744	CN-3MN	...	AL-6XN <sup>F</sup>	N08367
29Ni-20Cr-3Cu-2Mo	A 743, A 744	CN-7M	N08007	Alloy 20 <sup>C</sup>	N08020
24Ni-19Cr-3Mo-2Cu	A 743, A 744	CN-7MS	J94650	...	...
61Ni-16Mo-16Cr	A 494	CW-2M	N26455	C4 <sup>C</sup>	N06455
59Ni-18Mo-18Cr	A 494	CW-6M	N30107	...	...
60Ni-22Cr-9Mo-3.5Cb	A 494	CW-6MC	N26625	625 <sup>C</sup>	N06625
55Ni-17Mo-16Cr-4W	A 494	CW-12MW	N30002	C <sup>C</sup>	N10002
57Ni-13Mo-21Cr	A 494	CX-2MW	N26022	C22 <sup>C</sup>	N06022
74Ni-12Cr-4Bi-4Sn	A 494	CY-5SnBiM	N26055	...	...
72Ni-15Cr-8Fe	A 494	CY-40	N06040	600 <sup>C</sup>	N06600
95Ni	A 494	CZ-100	N02100	200 <sup>C</sup>	N02200
63Ni-29Cu-4Si	A 494	M-25S	N24025	...	...
63Ni-29Cu-2Cb	A 494	M-30C	N24130	...	...
63Ni-29Cu-Si	A 494	M-30H	N24030	...	...
67Ni-30Cu	A 494	M-35-1	N24135	400 <sup>C</sup>	N04400
67Ni-30Cu	A 494	M-35-2	N04020	400 <sup>C</sup>	N04400
65Ni-28Mo-2Fe	A 494	N-7M	N30007	B2 <sup>C</sup>	N10665
62Ni-28Mo-5Fe	A 494	N-12MV	N30012	B <sup>C</sup>	N10001
25Cr-7Ni-Mo-N	A 890	6A & CD3MCuWN	...	Zeron 100	J93380
41Ni-22Cr-3Mo-Fe	A 494	CU5MCuC	...	825	N28820

<sup>A</sup> ASTM designation.

<sup>B</sup> Common description, formerly used by AISI.

<sup>C</sup> Common name used by two or more producers; not a trademark.

<sup>D</sup> Proprietary trademark: Armco, Inc.

<sup>E</sup> Proprietary trademark: Avesta Sheffield AB.

<sup>F</sup> Proprietary trademark: Allegheny Ludlum Corporation.

### X3. ADDITION OF NEW GRADES TO PRODUCT SPECIFICATIONS COVERED BY A 781/A 781M

X3.1 Information required for the inclusion of new material grades in product specifications covered by A 781/A 781M:

1. At least one user should support the request.
2. A set of data from 10 production heats, this data should include:

X3.1.1 Chemical Composition.

X3.1.2 Mechanical properties as applicable to the product specification being cited. These may include but are not limited to the following:

X3.1.2.1 Ultimate tensile strength,

X3.1.2.2 Yield strength,

X3.1.2.3 Reduction in area,

X3.1.2.4 Elongation, and

X3.1.2.5 Impact properties (Charpy V).

X3.2 The test coupon size from which the test pieces are removed should be stated for each test.

X3.2.1 Heat treatment requirements.

X3.2.2 Weld procedure (welding should be carried out using commercially available consumables).





## **SUMMARY OF CHANGES**

Committee A01 has identified the location of selected changes to this standard since the last issue (D 781/D 781M – 01a) that may impact the use of this standard.

(1) Added new references to Sections 1 and 2.

*ASTM International takes no position respecting the validity of any patent rights asserted in connection with any item mentioned in this standard. Users of this standard are expressly advised that determination of the validity of any such patent rights, and the risk of infringement of such rights, are entirely their own responsibility.*

*This standard is subject to revision at any time by the responsible technical committee and must be reviewed every five years and if not revised, either reapproved or withdrawn. Your comments are invited either for revision of this standard or for additional standards and should be addressed to ASTM International Headquarters. Your comments will receive careful consideration at a meeting of the responsible technical committee, which you may attend. If you feel that your comments have not received a fair hearing you should make your views known to the ASTM Committee on Standards, at the address shown below.*

*This standard is copyrighted by ASTM International, 100 Barr Harbor Drive, PO Box C700, West Conshohocken, PA 19428-2959, United States. Individual reprints (single or multiple copies) of this standard may be obtained by contacting ASTM at the above address or at 610-832-9585 (phone), 610-832-9555 (fax), or [service@astm.org](mailto:service@astm.org) (e-mail); or through the ASTM website ([www.astm.org](http://www.astm.org)).*