



# Standard Specification for Compacted Graphite Iron Castings<sup>1</sup>

This standard is issued under the fixed designation A 842; the number immediately following the designation indicates the year of original adoption or, in the case of revision, the year of last revision. A number in parentheses indicates the year of last approval. A superscript epsilon ( $\epsilon$ ) indicates an editorial change since the last revision or reapproval.

## 1. Scope

1.1 This specification covers castings made of compacted graphite iron, that is described as cast iron with the graphite in compacted (vermiform) shapes and essentially free of flake graphite.

1.2 The values stated in SI units are to be considered as the standard.

1.3 No precise quantitative relationship can be stated between the properties of iron in the various locations of the same casting and those of a test bar cast from the same iron (see Appendix X1).

## 2. Referenced Documents

### 2.1 ASTM Standards:

A 247 Test Method for Evaluating the Microstructure of Graphite in Iron Castings<sup>2</sup>

E 8M Test Methods for Tension Testing of Metallic Materials (Metric)<sup>3</sup>

### 2.2 Federal Standard:

Fed. Std. No. 123 Marking for Shipment (Civil Agencies)<sup>4</sup>

### 2.3 American National Standard:

MIL-STD-129 Marking for Shipment and Storage<sup>5</sup>

## 3. Ordering Information

3.1 Orders for material to this specification shall include the following information:

3.1.1 ASTM designation and year of issue,

3.1.2 Grade of compacted graphite iron required as identified in Table 1,

3.1.3 Special properties if required, (see 4.1 and 10.1),

3.1.4 If samples other than those identified in Section 9 are required,

3.1.5 Certification if so designated by the purchaser, and

3.1.6 Special preparation for delivery if required.

<sup>1</sup> This specification is under the jurisdiction of ASTM Committee A-4 on Iron Castings and is the direct responsibility of Subcommittee A04.02 on Malleable and Ductile Iron Castings.

Current edition approved April 26, 1985. Published June 1985.

<sup>2</sup> Annual Book of ASTM Standards, Vol 01.02.

<sup>3</sup> Annual Book of ASTM Standards, Vol 03.01.

<sup>4</sup> Available from Standardization Documents Order Desk, Bldg. 4 Section D, 700 Robbins Ave., Philadelphia, PA 19111-5094, Attn: NPODS.

<sup>5</sup> Available from American National Standards Institute, 11 West 42nd Street, 13th Floor, New York, NY 10036.

TABLE 1 Tensile Requirements

	Grade <sup>A</sup> 250	Grade 300	Grade 350	Grade 400	Grade <sup>B</sup> 450
Tensile strength, min, MPa	250	300	350	400	450
Yield strength, min, MPa	175	210	245	280	315
Elongation in 50 mm, min, %	3.0	1.5	1.0	1.0	1.0

<sup>A</sup> The 250 grade is a ferritic grade. Heat treatment to attain required mechanical properties and microstructure shall be the option of the manufacturer.

<sup>B</sup> The 450 grade is a pearlitic grade usually produced without heat treatment with addition of certain alloys to promote pearlite as a major part of the matrix.

## 4. Chemical Composition

4.1 It is the intent of this specification to subordinate chemical composition to mechanical properties; however, any chemical requirement may be specified by agreement between the manufacturer and the purchaser.

## 5. Microstructure Requirements

5.1 Compacted graphite cast iron shall be examined metallographically for the acceptable graphite formation.

5.2 The metallographic examination shall be performed on a casting, a separately cast test coupon, as shown in Fig. 1 or on a test lug from a casting. The test coupon or casting lug shall represent the last metal from the treated batch. The casting lug dimension and location will be agreed on by manufacturer and purchaser.

5.3 When castings are produced to this specification by treating the iron in the mold for graphite form control, the manufacturer may use separately cast test coupons or cut test specimens from castings to qualify conformance of the microstructure requirements. When separately cast test coupons are used, the test coupons shall have a chemical composition representative of that in the castings, produced from that iron poured, and having a cooling rate equivalent to that obtained through use of test molds as shown in Figs. 1-4. The size of the cast coupon representing the castings shall be the option of the purchaser. In case no option is expressed, the manufacturer shall make the choice. When test specimens are to be taken from a casting, the location shall be agreed on by the purchaser and the manufacturer and documented on the casting drawing. It is the manufacturer's required responsibility to maintain adequate controls and documentation to assure the customer that test specimen microstructures are representative of microstructure in the castings shipped.

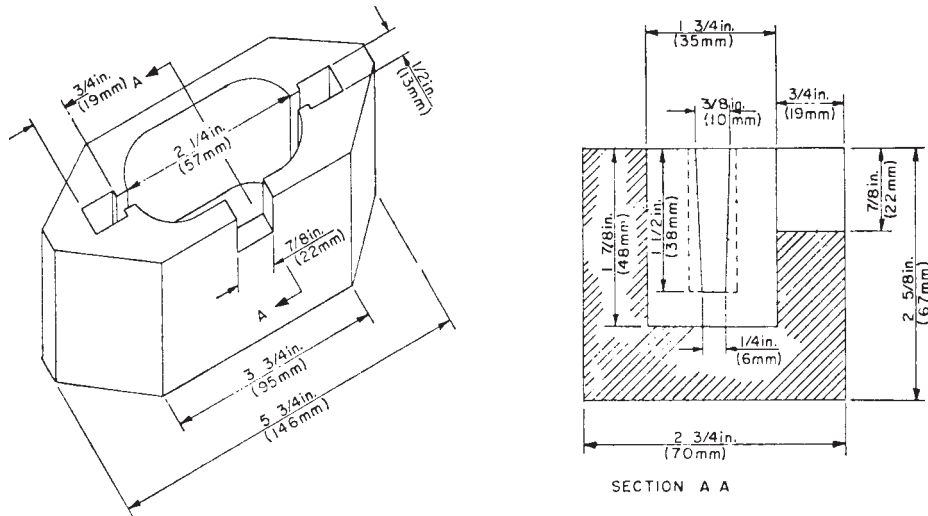

FIG. 1 Test Coupon for Microscopical Examination of Compacted Graphite Iron

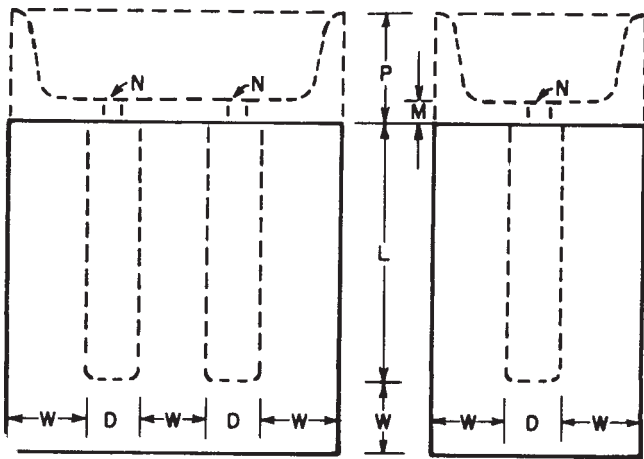

FIG. 2 Design and Dimensions for Mold for Separately Cast Cylindrical Test Bars

5.4 The acceptable graphite formation in the microstructure of the test coupon or casting lug shall contain 80 % minimum Type IV graphite (see Plate 1, Graphite Form Types of Test Method A 247). The percentage graphite can be arrived at by using the manual particle count, semiautomatic or automatic image analysis methods. Whichever method is used, the procedure should be agreed on between the manufacturer and the purchaser.

5.5 Unless otherwise specified, the matrix microstructure of castings covered by this specification shall be substantially free of primary cementite.

## 6. Tensile Requirements

6.1 The iron as represented by the test specimens shall conform to the requirements for tensile properties, as identified in Table 1.

6.2 The yield strength presented in Table 1 shall be determined at 0.2 % offset by the offset method as described in Test Methods E 8M. Other methods may be used by mutual agreement between manufacturer and purchaser.

NOTE—The length of the keel block shall be 6 in. (152 mm).

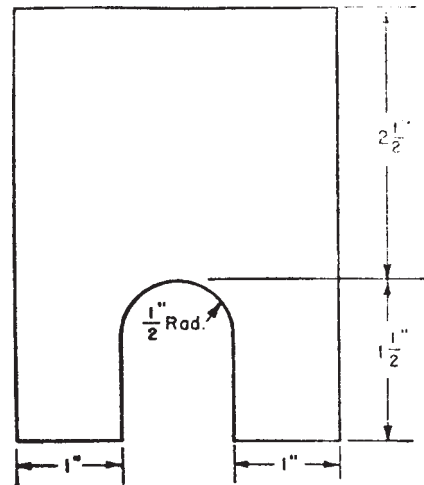

Metric Equivalents			
in.	mm	in.	mm
1/2	12.7	1 1/2	38.1
1	25.4	2 1/2	63.5

FIG. 3 Keel Block

## 7. Cast Test Bars

7.1 Test bars shall be separate castings poured from the same iron as the castings they represent. The 30 mm diameter cylindrical test bar shall be used as described in Table 2 and shown in Fig. 2.

7.2 Test coupons may also be cast to the size and shape of the keel block or modified keel block shown in Fig. 3 and Fig. 4 respectively.

7.3 Test bars and test coupons shall be cast in dried, baked, or chemically bonded molds consisting of an aggregate of silica sand with the appropriate binders. All molds shall have a thickness of sand adjacent to the test piece equal to or greater than the thickness of the piece.

7.4 The test bars or test coupons shall be poured from the same ladle or heat of iron as the castings they represent.

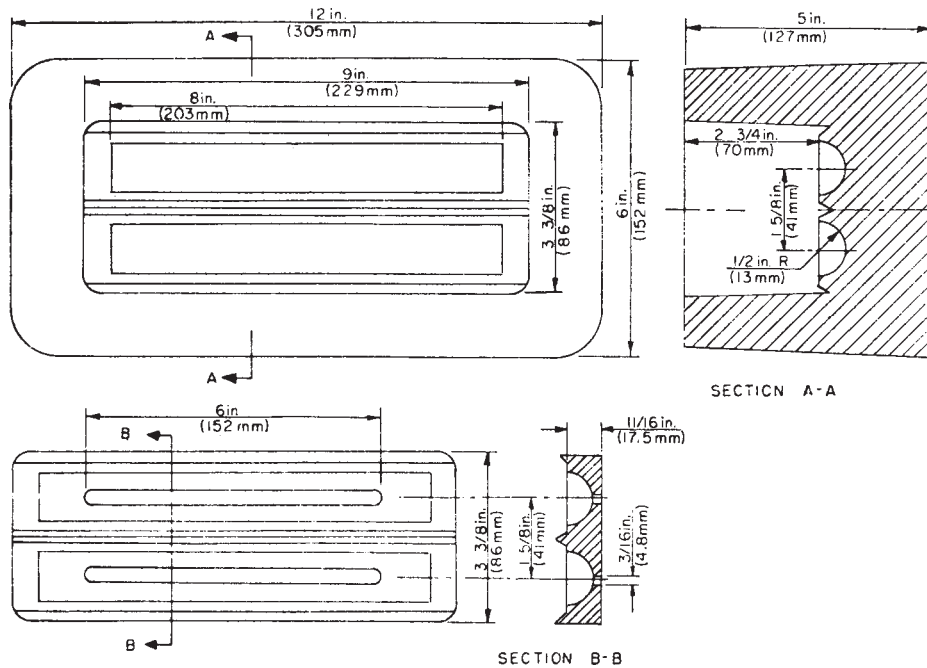

FIG. 4 Mold for Modified Keel Block

TABLE 2 Diameter and Length of Cast Test Bar

Test Bar	Nominal	As Cast Diameter, mm		Length, mm	
		Minimum	Maximum	Minimum	Maximum
B	30	29	31	150	230

7.5 Test bars and test coupons shall be subjected to the same thermal treatment as the castings they represent.

**8. Tension Test Specimen**

8.1 The standard round tension test specimen with 50 mm gage length described in Test Methods E 8M shall be used.

**9. Workmanship, Finish, and Appearance**

9.1 The surface of the casting shall be inspected visually for surface discontinuities such as cracks, hot tears, adhering sand or scale, cold shuts, and gas holes. Surface discontinuities shall meet visual acceptance standards mutually agreed on between the purchaser and the supplier.

9.2 No repairing by plugging or welding of any kind shall be permitted unless written permission is granted by the purchaser.

**10. Number of Tests and Retests**

10.1 The manufacturer shall cast a minimum of three test bars for each lot of castings intended to conform to this specification. The manufacturer shall make the specified tests. If any test specimen shows defective or improper machining, or obvious lack of continuity of metal, it may be discarded and replaced by another specimen from another test bar from the same lot. Only one bar need be tested if its results conform to the property requirements of this specification.

10.2 If after testing, a test specimen shows evidence of a defect, the results of the test may be invalidated and another made on a specimen from the same lot.

10.3 If the results of a valid test fail to conform to the requirements of this specification, two retests shall be made. If either retest fails to meet the specification requirements, the castings represented by these test specimens shall be rejected. A valid test is one wherein the specimen has been properly prepared and appears to be sound and on which the approved test procedure has been followed.

10.4 If sufficient separately cast test pieces are not available, the manufacturer shall have the option of removing a test specimen from a location of a representative casting as agreed upon between the manufacturer and purchaser.

10.5 If the first test results indicate that a thermal treatment is needed to meet the test requirements, the entire lot of castings and the representative test specimens shall be thermally treated together. Testing shall proceed in accordance with 10.1, 10.2, 10.3, and 10.4.

**11. Inspection**

11.1 Unless otherwise specified in the contract or purchase order, the manufacturer shall be responsible for carrying out all the tests and inspections required by this specification, using his own or other reliable facilities and he shall maintain complete records of all such tests and inspections. Such records shall be available for review by the purchaser.

11.2 The purchaser reserves the right to perform any of the inspections set forth in the specification where such inspections are deemed necessary to assure that supplies and services conform to the prescribed requirements.

**12. Certification**

12.1 When specified in the purchase order or contract, the manufacturer's or supplier's certification shall be furnished to the purchaser stating that samples representing each lot have been manufactured, tested, and inspected in accordance with this specification and the requirements have been met. When

specified in the purchase order or contract, a report of the test results shall be furnished.

### 13. Product Marking

13.1 When the size of the casting permits, each casting shall bear the cast date, the identifying mark of the manufacturer, and the part or pattern number at a location shown on the covering drawing and, if not shown on the drawing, the location should be at the discretion of the producer.

### 14. Packaging and Package Marking

14.1 Unless otherwise stated in the contract or order, the cleaning, preservation, and packing of castings for shipment shall be in accordance with the manufacturer's commercial

practice. Packaging and marking shall also be adequate to identify the contents and to ensure acceptance and safe delivery by the carrier for the mode of transportation employed.

14.2 *U.S. Government Procurement*—When specified in the contract or purchase order, marking for shipment shall be in accordance with the requirements of Federal Standard No. 123 for civil agencies and MIL-STD-129 for military activities.

### 15. Supplementary Requirements

15.1 When specified in the contract or purchase order, castings shall meet special requirements as to hardness, chemical composition, microstructure, pressure tightness, radiographic soundness, magnetic particle inspection dimensions, and surface finish.

## APPENDIX

### (Nonmandatory Information)

#### X1. MECHANICAL PROPERTIES OF CASTINGS

X1.1 The mechanical properties of iron castings are influenced by the cooling rate during and after solidification, by chemical composition (particularly carbon equivalent), by the design of the casting, by the design and nature of the mold, by graphite form, by the location and effectiveness of gates and risers, and by certain other factors. In compacted graphite cast iron, the proportions of nodular form and compacted form graphite may vary in varying sections due to the above factors.

X1.2 The cooling rate in the mold and, therefore, the properties developed in any particular section are influenced by the presence of cores, chills and chaplets, changes in section thickness, and the existence of bosses, projections, and inter-sections, such as junctions of ribs and bosses. Because of the complexity of the interactions of these factors, no precise quantitative relationship can be stated between the properties of the iron in various locations of the same casting or between the properties of a casting and those of a test specimen cast from the same iron. When such a relationship is important and must be known for a specification application, it may be determined by appropriate experimentation.

X1.3 When reliable information is unavailable on the relationship between properties in a casting and those in a separately cast test specimen, and where experimentation would be infeasible, the size of the test casting should be so selected as to approximate the thickness of the main or controlling section of the casting.

X1.4 Table X1.1 is a typical hardness range for the grades of compacted graphite cast iron in this specification. The chemical composition of the base iron used to produce compacted graphite cast iron may result in the hardness range moving to either side of the given range.

**TABLE X1.1 Compacted Graphite Cast Iron Hardness Range**

Grade	Hardness	BID <sup>A</sup>
250	179 max	(4.50 min)
300	143–207	(5.0–4.2)
350	163–229	(4.7–4.0)
400	197–255	(4.3–3.8)
450	207–269	(4.2–3.7)

<sup>A</sup> Brinell impression diameter (BID) is the diameter in millimetres of the impression of a 10 mm ball at a 3000 kg load.

*The American Society for Testing and Materials takes no position respecting the validity of any patent rights asserted in connection with any item mentioned in this standard. Users of this standard are expressly advised that determination of the validity of any such patent rights, and the risk of infringement of such rights, are entirely their own responsibility.*

*This standard is subject to revision at any time by the responsible technical committee and must be reviewed every five years and if not revised, either reapproved or withdrawn. Your comments are invited either for revision of this standard or for additional standards and should be addressed to ASTM Headquarters. Your comments will receive careful consideration at a meeting of the responsible technical committee, which you may attend. If you feel that your comments have not received a fair hearing you should make your views known to the ASTM Committee on Standards, 100 Barr Harbor Drive, West Conshohocken, PA 19428.*