



Standard Specification for High-Silicon Iron Pipe and Fittings¹

This standard is issued under the fixed designation A 861; the number immediately following the designation indicates the year of original adoption or, in the case of revision, the year of last revision. A number in parentheses indicates the year of last reappraisal. A superscript epsilon (ϵ) indicates an editorial change since the last revision or reappraisal.

This standard has been approved for use by agencies of the Department of Defense.

1. Scope

1.1 This specification covers high-silicon iron pipe and pipe fittings intended for corrosion-resistant service for both above- and below-grade construction.

1.2 Pipe and pipe fittings shall be the no-hub (MJ) or the hub and plain end design.

1.3 Pipe and pipe fittings shall be of the sizes specified in Table 1 and Table 2 and Figs. 1-71 or other sizes that shall be permitted to conform to the requirements given herein.

1.3.1 Pipe:

1.3.1.1 No-hub (MJ) (Fig. 1):

Size (in.)	Length (ft)
1½	7
2	7
3	7
4	7

1.3.1.2 Hub/Plain End (Fig. 35):

Size (in.)	Length (ft)
2	7
3	7
4	7
6	7
8	7
10	5
12	5
15	5

1.3.2 Fitting (No-hub) (MJ):

	Figs.
Quarter Bends	2
Sixth Bends	3
Return Bends	4
Double-Branch Quarter Bend	5
Eighth Bends	6
Sixteenth Bends	7
Long-Sweep Quarter Bends	8
Sanitary Y Branches	9
Double-Branch Sanitary Y	10
Sanitary Combination Y and ½ Bend	11
Double-Branch Sanitary Combination Y and ½ Bend	12

Sanitary T Branches	13
Double Branch Sanitary T	14
Sanitary Running Traps	15
Sanitary P Traps	16
Swivel Trap P-Style Short	17
Swivel Trap P-Style Long	18
Swivel Trap S-Style Long	19
Centrifugal Drum Trap P Swivel Type	20
Centrifugal Drum Trap S Swivel Type	21
Combination Cleanout and Test Tees	22
Coupling	23
Pipe Plugs	24
Cleanout Plugs	25
No-hub (MJ) Adapter	26
Reducers—Increases	27
Sink Outlet	28
Sink Overflows	29
Threaded Adapters	30
Trap Cleanout Details	31
No-hub (MJ) Adapter	32
(MJ) (No-hub) to Lead Adapter	33
Floor Drains	34

1.3.3 Fitting (Hub/Plain End):

	Figs.
Hub Plain End Pipe	35
Straight Tees	36
Sanitary T Branches	37
Sanitary Y Branches	38
Double-Branch Sanitary Tee	39
Double-Branch Sanitary Y	40
Double-Branch Sanitary Combination Y and ½ Bend (T-Y)	41
Short-Sweep Quarter Bends	42
Long-Sweep Quarter Bends	43
Sanitary Combination Y and ½ Bend (T-Y)	44
Quarter Bends	45
Sixth Bends	46
Eighth Bends	47
Sixteenth Bends	48
Sanitary Increases	49
Hub Strainers	50
Sanitary Reducers	51
Double Hubs	52
Pipe Plugs	53
Cleanout Plugs	54
Adapter—Plain end to Split Flange	55
Adapter—Hub to Split Flange	56
Combination Cleanout and Test Tees	57
Insertable Joints	58
Backwater Valves	59
Sanitary P Traps	60
Sanitary S Traps	61
Sanitary Running Traps	62
Floor Drains	63, 64, 65
Floor Drains	66

¹ This specification is under the jurisdiction of ASTM Committee A04 on Iron Castings and is the direct responsibility of Subcommittee A04.12 on Pipes and Tubes.

Current edition approved May 1, 2004. Published May 2004. Originally approved in 1986. Last previous edition approved in 2002 as A 861 – 02.

Floor Drains/Installation—Funnel Attachment	67, 68
Overflow	69
Sink Outlet	70
Detailed Cross Section of Cleanout	71
Chemical Composition	Table 3
Transverse Bend Test Minimum Requirements	Table 4

2. Referenced Documents

2.1 ASTM Standards:²

A 518/A 518M Specification for Corrosion-Resistant High-Silicon Iron Castings

E 350 Test Methods for Chemical Analysis of Carbon Steel, Low-Alloy Steel, Silicon Electrical Steel, Ingot Iron, and Wrought Iron

E 351 Test Methods for Chemical Analysis of Cast Iron—All Types

2.2 Other Standards:

Uniform Classification Rules³

National Motor Freight Classification³

3. Terminology

3.1 Definitions of Terms Specific to This Standard:

3.1.1 *hubless*—a pipe or fitting without a hub, sometimes called no-hub, joined by a coupling.

3.1.2 *MJ*—an abbreviation for mechanical joint.

3.1.3 *no-hub*—a pipe or fitting without a hub, sometimes described as hubless joined by a coupling.

4. Ordering Information

4.1 Ordering for material under this specification shall include as a minimum the following information:

4.1.1 ASTM designation, grade (see Table 3) and year of issue.

4.1.2 Description of the casting by figure number (see Figs. 1 through 71) or by manufacturer's drawings or catalog number, or both.

4.1.3 Length, diameter, and type of pipe and size and shape of fittings.

4.1.4 Quantity.

4.1.5 Certification requirements.

4.1.6 Special packaging requirements (see Section 14).

4.1.7 Supplemental requirements desired, if any.

5. Materials and Manufacture

5.1 The castings shall be produced by any established commercial practice applicable to high-silicon iron.

5.2 The castings shall be true to pattern, reasonably smooth, and free from defects that would make the castings unfit for the use for which they are intended.

6. Chemical Composition

6.1 An analysis of each heat shall be made by the manufacturer from a test sample that is representative of the heat and

that is taken during the heat. A heat shall consist of all castings poured from a furnace or crucible melt without recharging new metal into the furnace. The chemical composition thus determined shall conform to the requirements for the grade selected specified in Table 3.

6.2 A product analysis shall be permitted to be made by the purchaser from material representing the heat. The chemical composition thus determined shall meet the requirements specified in Table 3 or shall be subject to rejection by the purchaser.

6.3 Spectrometric or other instrumental methods and wet laboratory methods are acceptable for routine control determinations. Any method employed shall give essentially the same results as reference methods listed in Test Methods E 350. (For selected detailed methods of analysis, see Specification A 518, paragraph 6.4).

7. Heat Treatment

7.1 All centrifugally cast high-silicon iron pipe shall be supplied in the as-cast condition. All other pipe and fittings shall be supplied in the stress-relieved condition.

7.2 Stress relieving shall be performed as follows:

7.2.1 Hold the casting at 1650°F (870°C) minimum for 2 h plus an additional hour per inch of section thickness for castings over 2 in. in thickness.

7.2.2 Cool the castings to 400°F (205°C) maximum at a rate not to exceed 100°F (55°C)/15 min.

7.2.3 From 400°F (205°C) to ambient, the castings shall be permitted to be cooled in still, ambient air.

8. Joints

8.1 Acid-proof joints for hub/plain-end pipe shall require the use of an acid-proof rope packing.

8.2 No-hub pipe and fittings shall require a special acid resistant mechanical joint (MJ) coupling. One satisfactory coupling consists of an inner PTFE sleeve surrounded by neoprene. The two-bolt coupling is made of 300 series stainless steel.

8.3 High-silicon iron pipe can be cut with either manual or hydraulic snap cutters. Field cuts shall be permitted to be readily used with mechanical joint couplings to provide acceptable leak-proof joints.

9. Dimensions and Permissible Variations

9.1 Pipe:

9.1.1 Hub/plain-end pipe shall have a hub at one end and a plain end at the other and shall be cast in one piece (see Fig. 35).

9.1.2 Individual length of hub/plain-end pipe shall be either 7 or 5 ft nominal laying lengths as shown in Fig. 35.

9.1.3 Any deflections in the barrel of a single length of pipe shall not exceed 3/16 in.

9.1.4 No-hub pipe shall be cast in a single piece and conform to nominal dimensions shown in Fig. 1.

9.1.5 No dimension of hub/plain-end pipe shall exceed the tolerances specified in Table 1.

9.2 *Fittings*—All fittings shall conform to the nominal dimensions specified in applicable figures and be within the

² For referenced ASTM standards, visit the ASTM website, www.astm.org, or contact ASTM Customer Service at service@astm.org. For *Annual Book of ASTM Standards* volume information, refer to the standard's Document Summary page on the ASTM website.

³ Available from American Trucking Assoc., Traffic Dept., 2200 Mill Rd., Alexandria, VA 22314.

tolerances specified in Table 2 for fittings listed in Figs. 2 through 34 or in Table 1 for fittings listed in Figs. 36 through 39.

10. Inspection

10.1 *Inspection and Test by the Manufacturer*—Pipe and fittings shall be inspected by the manufacturer prior to shipment. Inspection by the manufacturer shall include all tests as specified herein. All tests and inspection with the exception of product analysis shall be made at the place of manufacture unless otherwise agreed upon.

10.2 *Inspection and Test by the Purchaser*—The manufacturer shall afford the purchaser’s inspector all reasonable facilities necessary to satisfy that the material is being produced and furnished in accordance with this specification. Foundry inspection by the purchaser shall not interfere unnecessarily with the manufacturer’s operations.

11. Rejection and Rehearing

11.1 Material that shows unacceptable discontinuities as determined by the acceptance standards specified in the order, subsequent to its acceptance at the manufacturer’s works, shall be rejected and the manufacturer shall be notified within 30 days unless otherwise agreed upon.

12. Certification

12.1 Upon request of the purchaser, the manufacturer shall certify that his product conforms to the requirements of this specification. The results of tests shall be furnished to the purchaser upon request as mutually agreed upon.

13. Product Marking

13.1 Each length of pipe and fitting shall be identified by the manufacturer’s name or identification mark. Marking shall be as not to impair the usefulness of the part.

13.2 Samples that represent rejected material shall be preserved for a minimum of 2 weeks from the date of transmission of the rejection report. In case of dissatisfaction with the results of the tests, the manufacturer shall be permitted to make claim for a rehearing within that time.

14. Packaging

14.1 Unless otherwise specified, the material shall be packaged in accordance with the supplier’s standard practice and acceptable to the carrier at the lowest rates. Containers and packing shall comply with Uniform Classification Rules or National Motor Freight Classification Rules.

15. Keywords

15.1 corrosion resistant; fittings; high-silicon iron; hubless; hub/plain-end; no-hub; plain-end

SUPPLEMENTARY REQUIREMENTS

The following supplementary requirements are for use when desired by the purchaser. They shall not apply unless specified in the order, in which event the specified tests shall be made by the manufacturer before shipment of the castings.

S1. Transverse Bend Tests

S1.1 Transverse bend properties shall be determined from material representing each heat and shall meet the requirements shown in Table S1.1. Properties thus measured shall be considered representative of the quality of the high-silicon iron but may not represent properties in the actual castings.

S1.2 Transverse bend tests shall be conducted in accordance with the manufacturer’s established test procedure for transverse bend test including the following:

S1.2.1 The specimens shall not be machined or ground and shall conform to the dimensions in Fig. 72.

S1.2.2 The specimens shall be cast in patterns in accordance with Fig. 73.

S1.2.3 The specimens shall be heat treated in accordance with Section 7.

S1.2.4 The actual breaking load shall be reported. The requirements of Table 2 allow for any deviation due to variations in test bar diameter. The deflection at fracture shall also be reported without correction.

S1.2.5 The rate of loading shall produce 0.025-in. (0.64-mm) deflection in 50 to 70 s. Continue loading at this rate until the specimen fractures.

TABLE S1.1 Transverse Bend Test Minimum Requirements^A

Load at Center, min, lbf (N)	930 (4090)
Deflection at Center, min, in. (mm)	0.026 (0.66)

^ATest bars are to be tested on supports 12 in. (305 mm) apart.

S2. Hydrostatic Testing

S2.1 Hydrostatic tests at 40 psi, minimum, shall be conducted on all castings specified in the order. Any leak revealed by this test shall be cause for rejection for the individual piece. A leak shall include any evidence of moisture on the outside diameter of the part established to have occurred due to through-wall leakage.

TABLE 1 Tolerances for High-Silicon Iron Hub/Plain-End Pipe

NOTE 1—1 in. = 25.4 mm.

Size, in.	Wall Thickness, in.	ID Tolerance, in.	OD Tolerance, in.
2	± 1/32	± 1/32	± 1/32
3	± 1/32	± 1/32	± 1/32
4	± 1/32	± 1/32	± 1/32
6	± 1/32	± 1/32	± 3/64
8	± 1/32	± 1/8	± 1/8
10	± 1/8	± 1/8	± 1/8
12	± 1/8	± 1/8	± 1/8
15	± 1/8	± 1/8	± 1/8

TABLE 2 Tolerances for High-Silicon Iron Fittings

NOTE 1—1 in. = 25.4 mm.

Size, in.	ID Tolerance, in.	OD Tolerance, in.	Stop Lug Depth Tolerance, in.
1 1/2	± 1/16	± 1/16	± 1/16
1 1/2 × 1 1/2	± 1/16	± 1/16	± 1/16
2	± 1/16	± 1/16	± 1/16
2 × 1 1/2	± 1/16	± 1/16	± 1/16
2 × 2	± 1/16	± 1/16	± 1/16
3	± 1/16	± 1/16	± 1/16
3 × 1 1/2	± 1/16	± 1/16	± 1/16
3 × 2	± 1/16	± 1/16	± 1/16
3 × 3	± 1/16	± 1/16	± 1/16
4	± 1/16	± 1/16	± 1/16
4 × 1 1/2	± 1/16	± 1/16	± 1/16
4 × 2	± 1/16	± 1/16	± 1/16
4 × 3	± 1/16	± 1/16	± 1/16
4 × 4	± 1/16	± 1/16	± 1/16

TABLE 3 Chemical Composition

Element	Composition, Weight %	
	Grade 1	Grade 2
Carbon	0.65–1.10	0.75–1.15
Manganese	1.50 max	1.50 max
Silicon	14.20–14.75	14.20–14.75
Chromium	0.50 max	3.25–5.00
Molybdenum	0.50 max	0.40–0.60
Copper	0.50 max	0.50 max

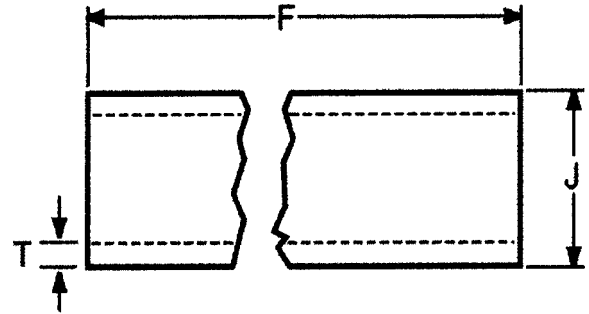

Size, in.	J, in.	F, in.	t, in.
1 1/2	2 3/16 (2.19)	84	5/16
2	2 11/16 (2.69)	84	5/16
3	3 49/64 (3.77)	84	5/16
4	4 49/64 (4.77)	84	5/16

NOTE 1—1 in. = 25.4 mm.
FIG. 1 No-Hub Pipe (MJ)

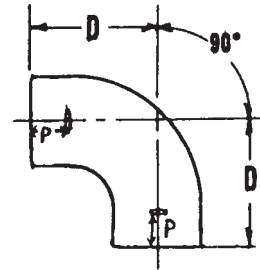

Size, in.	D, in.	ID, in.	OD, in.	Stop Lug Depth (P), in.
1 1/2	4 1/4	1 1/2	2 3/16 (2.19)	1 1/32
2	4 1/2	2	2 5/8 (2.62)	1 1/32
2 × 1 1/2	4 3/16 × 4 1/2	2 × 1 1/2	2 5/8 × 2 3/16	1 1/32
3	5	3	3 3/4 (3.75)	1 1/32
4	5 1/2	4	4 3/4 (4.75)	1 1/32

NOTE 1—1 in. = 25.4 mm.
FIG. 2 Quarter Bends

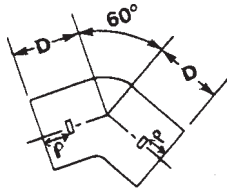
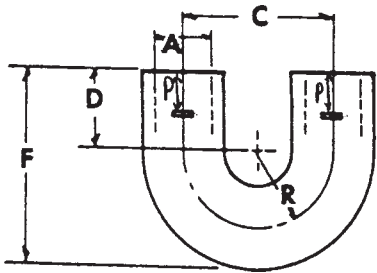

TABLE 3 Continued

Size, in.	D, in.	ID, in.	OD, in.	Stop Lug Depth (P), in.
1½	3	1½	2¾	1½
2	3¼	2	2⅝	1½
3	3½	3	3¾	1½
4	3¾	4	4¾	1½

NOTE 1—1 in. = 25.4 mm.

FIG. 3 Sixth Bends



Size, in.	C, in.	D, in.	F, in.	R, in.	ID, in.	OD, in.	Stop Lug Depth (P), in.
1½	4	2	5⅜	2	1½	2¾	1½
2	4¾	2	5⅞	2⅜	2	2⅝	1½

NOTE 1—1 in. = 25.4 mm.

FIG. 4 Return Bends

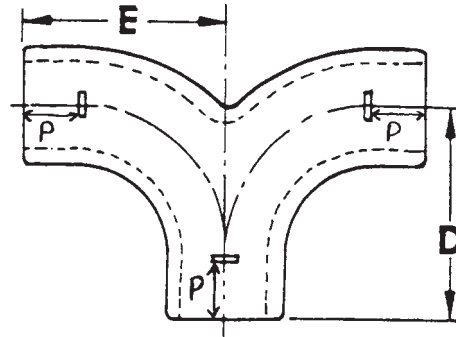

Size, in.	D, in.	E, in.	ID, in.	OD, in.	Stop Lug Depth (P), in.
1½	3⅞	3¾	1½	2¾	1½

NOTE 1—1 in. = 25.4 mm.

FIG. 5 Double-Branch Quarter Bend

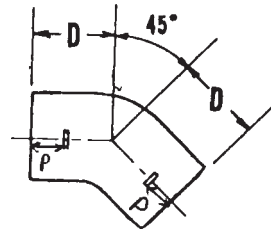

Size, in.	D, in.	ID, in.	OD, in.	Stop Lug Depth (P), in.
1½	2½	1½	2¾	1½
2	2¾	2	2⅝	1½
3	3	3	3¾	1½
4	3¼	4	4¾	1½

NOTE 1—1 in. = 25.4 mm.

FIG. 6 Eight Bends

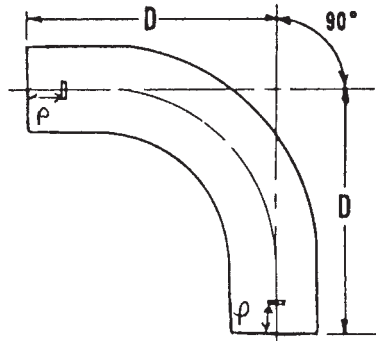

TABLE 3 Continued

Size, in.	D, in.	ID, in.	OD, in.	Stop Lug Depth (P), in.
1½	2	1½	2¾ ₁₆	1½ ₃₂
2	2½ ₈	2	2 ⁵ / ₈	1½ ₃₂
3	2¼	3	3¾	1½ ₃₂
4	2¾ ₈	4	4¾	1½ ₃₂

NOTE 1—1 in. = 25.4 mm.

FIG. 7 Sixteenth Bends



Size, in.	D, in.	ID, in.	OD, in.	Stop Lug Depth (P), in.
1½	9¼	1½	2¾ ₁₆	1½ ₃₂
2	9½	2	2 ⁵ / ₈	1½ ₃₂
3	10	3	3¾	1½ ₃₂
4	10½	4	4¾	1½ ₃₂

FIG. 8 Long-Sweep Quarter Bends

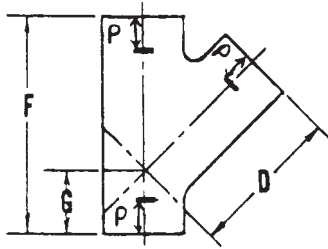
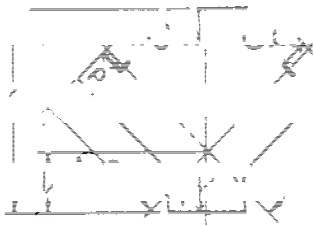

TABLE 3 Continued

Size, in.	D, in.	F, in.	G, in.	ID, in.	OD, in.	Stop Lug Depth (P), in.
1/2 x 1/2	4 5/8	6 1/2	1 7/8	1 1/2 x 1 1/2	2 3/16 x 2 3/16	1 1/32
2 x 1 1/2	4 7/8	6 1/2	1 5/8	2 x 1 1/2	2 5/8 x 2 3/16	1 1/32
2 x 2	4 5/8	6 3/8	2	2 x 2	2 5/8 x 2 5/8	1 1/32
3 x 1 1/2	5 5/8	6 1/2	1 1/4	3 x 1 1/2	3 3/4 x 2 3/16	1 1/32
3 x 2	5 7/8	7 1/8	1 1/2	3 x 2	3 3/4 x 2 5/8	1 1/32
3 x 3	6 3/8	8 5/8	2 1/4	3 x 3	3 3/4 x 3 3/4	1 1/32
4 x 1 1/2	6 5/8	7 1/2	1 3/8	4 x 1 1/2	4 3/4 x 2 3/16	1 1/32
4 x 2	6 3/8	7 1/2	1 3/8	4 x 2	4 3/4 x 2 5/8	1 1/32
4 x 3	7 1/8	8 3/4	1 3/4	4 x 3	4 3/4 x 3 3/4	1 1/32
4 x 4	7 3/8	10 1/4	2 5/8	4 x 4	4 3/4 x 4 3/4	1 1/32

NOTE 1—1 in. = 25.4 mm.

FIG. 9 Sanitary Y Branches



Size, in.	D, in.	F, in.	G, in.	ID, in.	OD, in.	Stop Lug Depth (P), in.
1 1/2 x 1 1/2	4 5/8	6 1/2	1 7/8	1 1/2 x 1 1/2	2 3/16 x 2 3/16	1 1/32
2 x 1 1/2	4 7/8	6 1/2	1 5/8	2 x 1 1/2	2 5/8 x 2 3/16	1 1/32
2 x 2	4 5/8	6 3/8	2	2 x 2	2 5/8 x 2 5/8	1 1/32
3 x 1 1/2	5 5/8	6 1/2	1 1/4	3 x 1 1/2	3 3/4 x 2 3/16	1 1/32
3 x 2	5 7/8	7 1/8	1 1/2	3 x 2	3 3/4 x 2 5/8	1 1/32
3 x 3	6 3/8	8 5/8	2 1/4	3 x 3	3 3/4 x 3 3/4	1 1/32
4 x 2	6 3/8	7 1/2	1 3/8	4 x 2	4 3/4 x 2 5/8	1 1/32
4 x 3	7 1/8	8 3/4	1 3/4	4 x 3	4 3/4 x 3 3/4	1 1/32
4 x 4	7 3/8	10 1/4	2 5/8	4 x 4	4 3/4 x 4 3/4	1 1/32

NOTE 1—1 in. = 25.4 mm.

FIG. 10 Double-Branch Sanitary Y

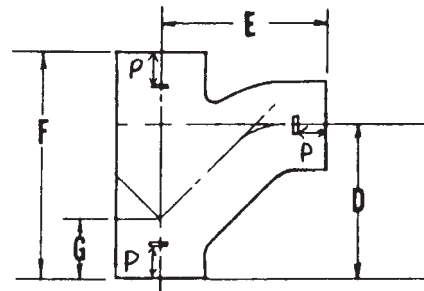

Size, in.	D, in.	E, in.	F, in.	G, in.	ID, in.	OD, in.	Stop Lug Depth (P), in.
1 1/2 x 1 1/2	4 3/4	5 3/8	6 1/2	1 7/8	1/2 x 1 1/2	2 3/16 x 2 3/16	1 1/32
2 x 1 1/2	4 3/4	5 3/4	6 1/2	1 5/8	2 x 1 1/2	2 5/8 x 2 3/16	1 1/32
2 x 2	5	5 7/8	6 3/8	1 7/8	2 x 2	2 5/8 x 2 5/8	1 1/32
3 x 1 1/2	4	5 1/4	6 1/2	1 5/8	3 x 1 1/2	3 3/4 x 2 3/16	1 1/32
3 x 2	5	6 1/4	7 1/8	1 1/2	3 x 2	3 3/4 x 2 5/8	1 1/32
3 x 3	6 1/4	7	8 1/2	2 1/4	3 x 3	3 3/4 x 3 3/4	1 1/32
4 x 1 1/2	4 5/16	6 1/8	6 3/8	1 3/8	4 x 1 1/2	4 3/4 x 2 3/16	1 1/32
4 x 2	5	6 3/8	7 3/8	1 3/8	4 x 2	4 3/4 x 2 5/8	1 1/32
4 x 3	6	7 1/4	8 3/4	1 3/4	4 x 3	4 3/4 x 3 3/4	1 1/32
4 x 4	7 3/8	8	10 1/4	2 5/8	4 x 4	4 3/4 x 4 3/4	1 1/32

NOTE 1—1 in. = 25.4 mm.

FIG. 11 Sanitary Combination Y and 1/2 Bend

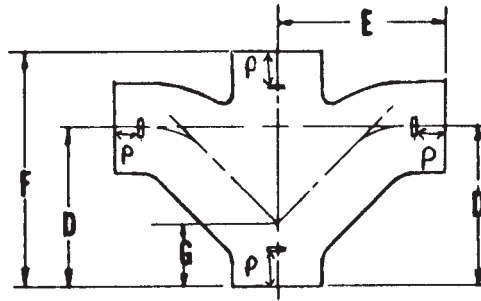
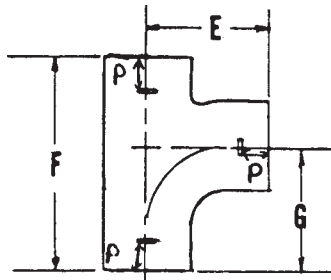

TABLE 3 Continued

Size, in.	D, in.	E, in.	F, in.	G, in.	ID, in.	OD, in.	Stop Lug Depth (P), in.
1½ × 1½	4¾	5⅞	6½	7⅞	1½ × 1½	2⅜ × 2⅜	1⅜
2 × 1½	4¾	5¾	6½	1⅞	2 × 1½	2⅝ × 2⅜	1⅜
2 × 2	5	5⅞	6⅞	1⅞	2 × 2	2⅝ × 2⅝	1⅜
3 × 1½	4¼	5¼	6½	1⅞	3 × 1½	3¾ × 2⅜	1⅜
3 × 2	5	6¼	7⅞	1½	3 × 2	3¾ × 2⅝	1⅜
3 × 3	6¼	7	8½	2¼	3 × 3	3¾ × 3¾	1⅜
4 × 2	5	6⅞	7⅞	1⅞	4 × 2	4¾ × 2⅝	1⅜
4 × 3	6	7¼	8¾	1¾	4 × 3	4¾ × 3¾	1⅜
4 × 4	7⅞	8	10¼	2⅞	4 × 4	4¾ × 4¾	1⅜

NOTE 1—1 in. = 25.4 mm.

FIG. 12 Double-Branch Sanitary Combination Y and 1/8 Bend



Size, in.	E, in.	F, in.	G, in.	ID, in.	OD, in.	Stop Lug Depth (P), in.
1½ × 1½	4¼	6¾	4¼	1½ × 1½	2⅜ × 2⅜	1⅜
2 × 1½	4½	6¾	4¼	2 × 1½	2⅝ × 2⅜	1⅜
2 × 1½ × 1½	4½	6¾	4¼	2 × 1½ × 1½	2⅝ × 2⅜ × 2⅜	1⅜
2 × 2	4½	6⅞	4½	2 × 2	2⅝ × 2⅝	1⅜
3 × 1½	5	6¾	4¼	3 × 1½	3¾ × 2⅜	1⅜
3 × 2	5	7¼	4½	3 × 2	3¾ × 2⅝	1⅜
3 × 3	5	8⅞	5	3 × 3	3¾ × 3¾	1⅜
4 × 1½	5⅞	6⅞	4⅞	4 × 1½	4¾ × 2⅜	1⅜
4 × 2	5½	7¼	4½	4 × 2	4¾ × 2⅝	1⅜
4 × 3	5½	8¼	5	4 × 3	4¾ × 3¾	1⅜
4 × 4	5½	9⅞	5½	4 × 4	4¾ × 4¾	1⅜

NOTE 1—1 in. = 25.4 mm.

FIG. 13 Sanitary T Branches

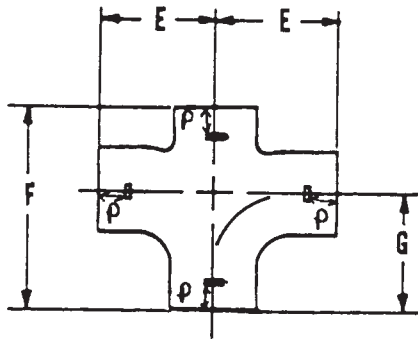
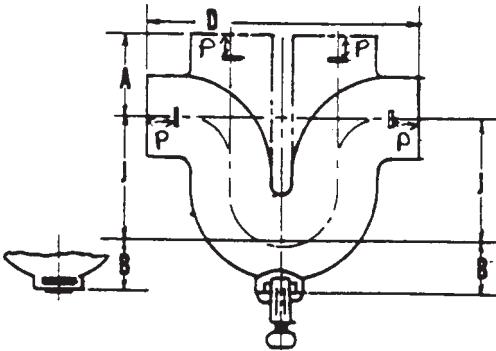

TABLE 3 Continued

Size, in.	E, in.	F, in.	G, in.	ID, in.	OD, in.	Stop Lug Depth (P), in.
1½ × 1½	4¼	6¾	4¼	1½ × 1½	2¾ × 2¾	1½
2 × 1½	4½	6¾	4¼	2 × 1½	2¾ × 2¾	1½
2 × 2	4½	6¾	4½	2 × 2	2¾ × 2¾	1½
3 × 1½	5	6¾	4¼	3 × 1½	3¾ × 2¾	1½
3 × 2	5	7¼	4½	3 × 2	3¾ × 2¾	1½
3 × 3	5	8¾	5	3 × 3	3¾ × 3¾	1½
4 × 2	5½	7¼	4½	4 × 2	4¾ × 2¾	1½
4 × 3	5½	8¾	5	4 × 3	4¾ × 3¾	1½
4 × 4	5½	9¾	5½	4 × 4	4¾ × 4¾	1½

NOTE 1—1 in. = 25.4 mm.

FIG. 14 Double-Branch Sanitary T



Size, in.	A, in.	B, in.	C, in.	D, in.	J, in.	R, in.	ID, in.	OD, in.	Stop Lug Depth (P), in.
1½	2¾	1⅝	5	10	4	1¾	1½	2¾	1½
2	3½	1⅞	5½	11	4	2	2	2¾	1½
3	4	2⅞	6½	13	5½	2½	3	3¾	1½
4	4½	3	7½	15	6½	3	4	4¾	1½

NOTE 1—1 in. = 25.4 mm.

FIG. 15 Sanitary Running Traps

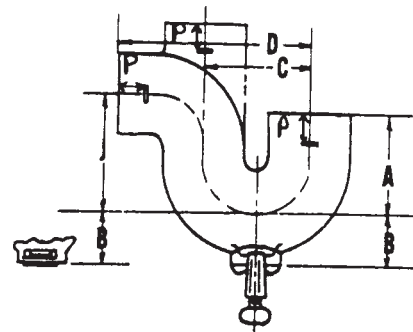

Size, in.	A, in.	B, in.	C, in.	D, in.	J, in.	R, in.	ID, in.	OD, in.	Stop Lug Depth (P), in.
1½	3¾	1⅝	3½	6¾	4	1¾	1½	2¾	1½
2	4	1⅞	4	7½	4	2	2	2¾	1½
3	4½	2⅞	5	9	5½	2½	3	3¾	1½
4	5	3	6	10½	6½	3	4	4¾	1½

NOTE 1—1 in. = 25.4 mm.

FIG. 16 Sanitary P Traps

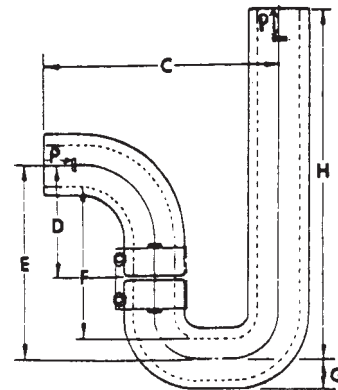

Size, in.	C, in.	D, in.	E, in.	F, in.	G, in.	H, in.	ID, in.	OD, in.	Stop Lug Depth (P), in.
1½	8¾	4	6⅞	5⅞	1¾	12½	1½	2¾	1½
2	9¾	4½	7¾	5¾	1⅞	12	2	2¾	1½

NOTE 1—1 in. = 25.4 mm.

FIG. 17 Swivel Trap P-Style Short

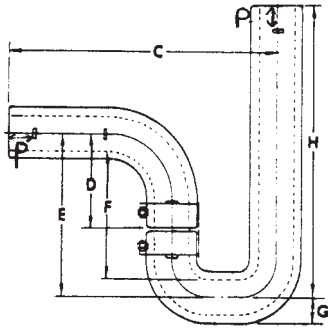

TABLE 3 Continued

Size, in.	C ^A , in.	D, in.	E, in.	F, in.	G, in.	H ^A , in.	ID, in.	OD, in.	Stop Lug Depth (P), in.
1½	12¾	4	6 ¹⁵ / ₁₆	5 ⁷ / ₁₆	1 ³ / ₃₂	12½	1½	2 ³ / ₁₆	1 ¹ / ₃₂

^AFor shorter C or H dimension, snap-cut to desired length.

NOTE 1—1 in. = 25.4 mm.

FIG. 18 Swivel Trap P-Style Long

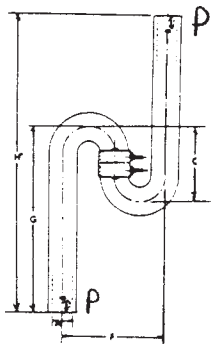

Size, in.	C, in.	F, in.	G, in.	H, in.	ID, in.	OD, in.	Stop Lug Depth (P), in.
1½	6	8	14 ³ / ₈	22 ³ / ₄	1½	2 ³ / ₁₆	1 ¹ / ₃₂
2	6 ³ / ₈	10½	12	17 ⁵ / ₈	2	2 ⁵ / ₈	1 ¹ / ₃₂

NOTE 1—1 in. = 25.4 mm.

FIG. 19 Swivel Type-S Style Long

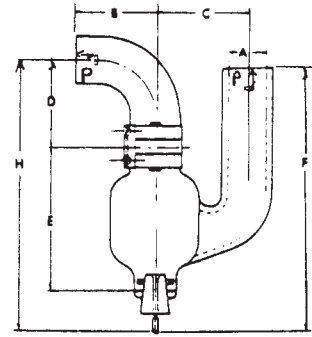

Size, in.	B, in.	C, in.	D, in.	E, in.	F, in.	H, in.	ID, in.	OD, in.	Stop Lug Depth (P), in.
1½	8	4	4	6¾	12¾	12 ¹⁵ / ₁₆	1½	2 ³ / ₁₆	1 ¹ / ₃₂
2	4½	4¾	4½	7 ⁹ / ₁₆	14¼	14¼	2	2 ⁵ / ₈	1 ¹ / ₃₂

NOTE—1 in. = 25.4 mm.

FIG. 20 Centrifugal Drum Trap P Swivel Type

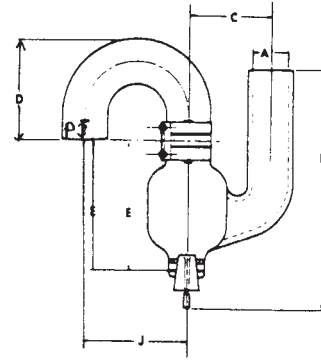

Size, in.	C, in.	D, in.	E, in.	F, in.	J, in.	ID, in.	OD, in.	Stop Lug Depth (P), in.
1½	4	5 ³ / ₃₂	6¾	12¾	4	1½	1 ¹ / ₈	1 ¹ / ₃₂
1½	4	15 ¹⁵ / ₃₂	6¾	12¾	4	1½	1 ¹ / ₈	1 ¹ / ₃₂
2	4¾	5 ¹¹ / ₁₆	7 ⁹ / ₁₆	14¼	4¾	2	2	1 ¹ / ₃₂

NOTE 1—1 in. = 25.4 mm.

FIG. 21 Centrifugal Drum Trap S Swivel Type

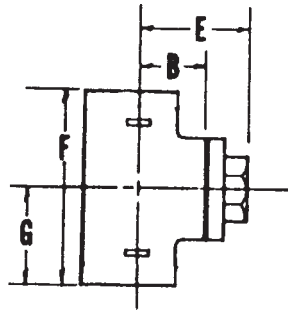
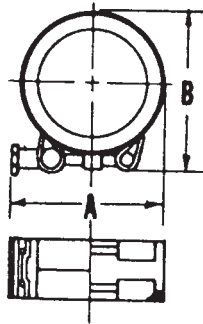

TABLE 3 Continued

Size, in.	B, in.	E, in.	F, in.	G, in.
2	27/16	33/4	67/8	37/16
3	33/8	411/16	83/8	43/16
4	37/8	57/16	93/8	411/16

NOTE 1—1 in. = 25.4 mm.

FIG. 22 Combination Cleanout and Test Tees



Size, in.	A, in.	B, in.
1 1/2	3 3/8	2 7/8
2	4	3 3/8
3	4 7/16	4 3/16
4	4 15/16	5 3/16

NOTE 1—1 in. = 25.4 mm.

FIG. 23 Coupling



Size, in.	F, in.
1/2	2
2	2 1/2
3	2 1/2
4	2 1/2

NOTE 1—1 in. = 25.4 mm.

FIG. 24 Pipe Plugs

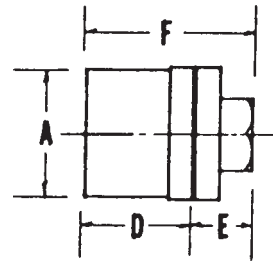

Size, in.	A, in.	D, in.	E, in.	F, in.
1 1/2	2 3/16	2 1/4	1 5/16	3 9/16
2	2 21/32	2 1/4	1 5/16	3 9/16
3	3 3/4	2 1/2	1 3/8	3 7/8
4	4 3/4	2 3/4	1 7/16	4 3/16

NOTE 1—1 in. = 25.4 mm.

FIG. 25 Cleanout Plugs

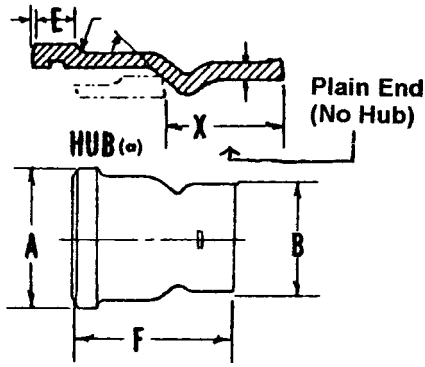
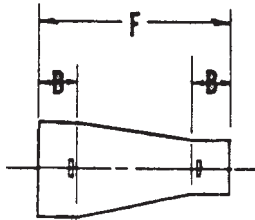

TABLE 3 Continued

Size, in.	A, in.	B, in.	E, in.	F, in.
1½ × 1½	3 ²³ / ₃₂	2¼	9/16	4 ⁵ / ₈
1½ × 2	3 ¹³ / ₁₆	2 ²¹ / ₃₂	9/16	4 ⁵ / ₈
1½ × 3	3 ¹³ / ₁₆	3 ¹³ / ₁₆	9/16	4 ⁵ / ₈
1½ × 4	3 ¹³ / ₁₆	4 ¹³ / ₁₆	9/16	4 ⁷ / ₈
2 × 2	4 ⁵ / ₁₆	2 ²³ / ₃₂	5/8	5 ¹ / ₈
2 × 3	4 ⁵ / ₁₆	3 ¹³ / ₁₆	5/8	4 ³ / ₄
2 × 4	4 ⁵ / ₁₆	4 ¹³ / ₁₆	5/8	5
3 × 3	5 ⁵ / ₁₆	3 ¹³ / ₁₆	1 ¹ / ₁₆	5 ³ / ₈
4 × 4	6 ³ / ₃₂	4 ⁷ / ₈	1 ¹ / ₁₆	5 ⁹ / ₁₆

NOTE 1—1 in. = 25.4 mm.

FIG. 26 Adapter/Hub to No-Hub



Size, in.	B, in.	F, in.
2 × 1½	1½	8
3 × 1½	1½	8
3 × 2	1½	8
4 × 1½	1½	8
4 × 2	1½	8
4 × 3	1½	8

NOTE 1—1 in. = 25.4 mm.

FIG. 27 Reducers-Increasers

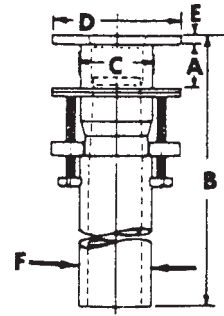

Size, in.	A, in.	B, in.	C, in.	D, in.	E, in.	F, in.
1½	0 to 2	10¼	1 ⁷ / ₈	3 ⁵ / ₁₆	¼	2 ³ / ₁₆

NOTE 1—1 in. = 25.4 mm.

FIG. 28 Sink Outlet

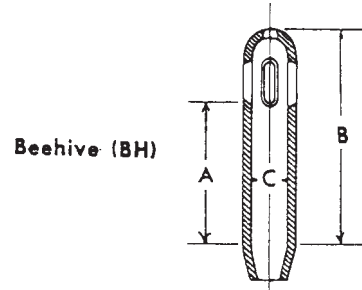

A, in. ⁴	B, in. ⁴	C, in.
4	6 ¹ / ₈	1
6	8 ¹ / ₈	1
8	10 ¹ / ₈	1

⁴Dimension A and B will vary depending upon the sink strainer in which overflow is placed, depth of counterbore, and so forth, Dimension B is given only as a guide.

NOTE 1—1 in. = 25.4 mm.

FIG. 29 Sink Overflows

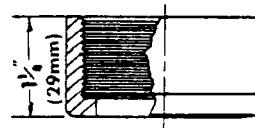

NPSM Threads
(National Pipe Straight Mechanical)

Type	Size, in.
AD-7	1½ Outlet to 1½ MJ
AD-8	1½ Outlet to 2 MJ
AD-10	2 Outlet to 2 MJ

NOTE 1—1 in. = 25.4 mm.

FIG. 30 Threaded Adapters

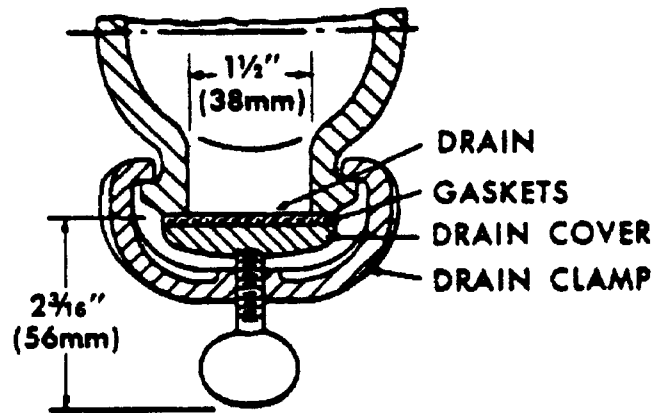

NOTE 1—1 in. = 25.4 mm.
FIG. 31 Trap Cleanout Details

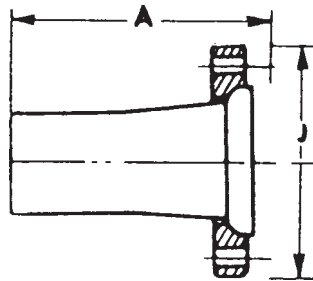

TABLE 3 Continued

Size, in.	A, in.	J, in.
2	5 3/4	6
3	7	7 1/2
4	8	9

NOTE 1—Flange dimensions are 150 lb ANSI standard.
NOTE 2—1 in. = 25.4 mm.

FIG. 32 Adapter—No-Hub and Split Flange

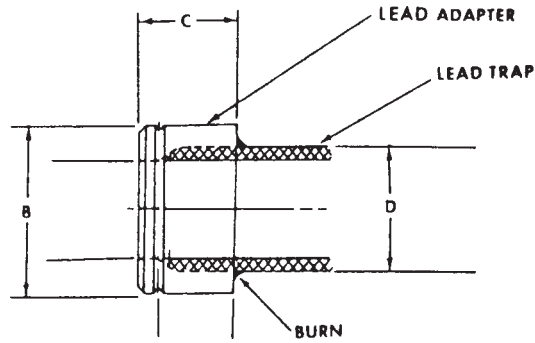
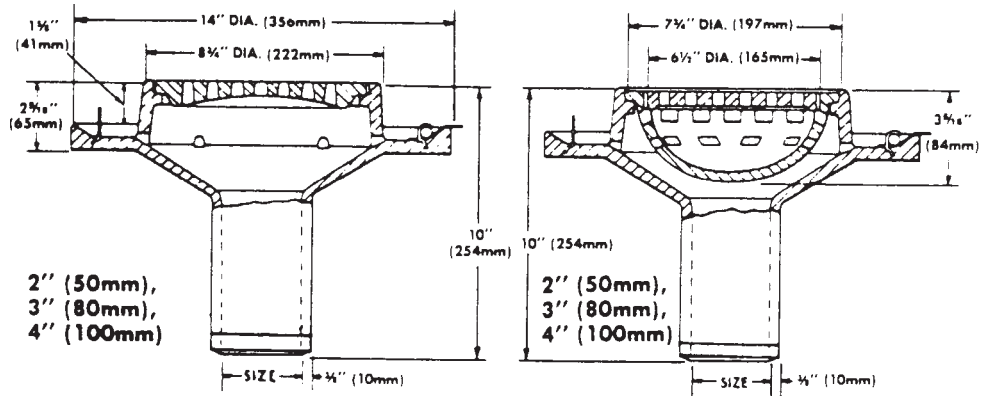

TABLE 3 Continued

Type	Size, in.	B, in.	C, in.	D, in.
AD-11	1½	2¼	1½	1 ²⁵ / ₃₂
AD-12	2	2 ²³ / ₃₂	1½	2 ⁹ / ₃₂

NOTE 1—1 in. = 25.4 mm.

FIG. 33 MJ to Lead Adapter



NOTE 1—1 in. = 25.4 mm.

FIG. 34 Floor Drains

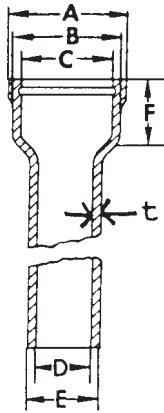

TABLE 3 Continued

Size, in.	A, in.	B, in.	C, in.	D, in.	E, in.	F, in.
2	4 ⁹ / ₁₆	4 ³ / ₁₆	3 ⁵ / ₁₆	2 ¹ / ₃₂	2 ¹¹ / ₁₆	2 ⁵ / ₈
3	5 ⁵ / ₁₆	5 ⁹ / ₁₆	4 ⁵ / ₁₆	3 ¹ / ₈	3 ²⁵ / ₃₂	2 ⁵ / ₈
4	6 ³ / ₈	6 ³ / ₁₆	5 ⁵ / ₁₆	4 ¹ / ₈	4 ²⁵ / ₃₂	2 ⁵ / ₈
6	8 ¹⁷ / ₃₂	8 ¹¹ / ₃₂	7 ⁵ / ₁₆	5 ¹⁵ / ₁₆	6 ¹ / ₁₆	3
8	11 ¹ / ₄	10 ³ / ₄	9 ⁵ / ₈	8 ¹ / ₄	9	3
10	14 ¹ / ₄	13 ³ / ₄	12 ¹ / ₄	10	11 ¹ / ₄	3 ⁷ / ₈
12	16 ³ / ₄	16	14 ¹ / ₂	12	13 ¹ / ₄	4
15	20 ¹ / ₄	19 ³ / ₄	17 ³ / ₄	15	16 ³ / ₄	4 ¹ / ₈

Size, in.	t, in.	Weight, lb	Working Length, ft	Overall Length
2	5 ¹ / ₁₆	0.31	7	7 ft 2 ⁵ / ₈ in.
3	5 ¹ / ₁₆	0.31	7	7 ft 2 ⁵ / ₈ in.
4	5 ¹ / ₁₆	0.31	7	7 ft 2 ⁵ / ₈ in.
6	1 ³ / ₃₂	0.40	7	7 ft 3 in.
8	1 ³ / ₃₂	0.40	7	7 ft 3 in.
10	5 ¹ / ₈	0.62	7	7 ft 3 ⁷ / ₈ in.
12	5 ¹ / ₈	0.62	5	5 ft 4 in.
15	7 ¹ / ₈	0.75	5	5 ft 4 ¹ / ₈ in.

NOTE 1—1 in. = 25.4 mm.

FIG. 35 Hub and Plain End Pipe

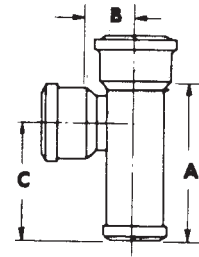

Size, in.	Weight, lb	A, in.	B, in.	C, in.
2 × 1 ¹ / ₂	11	8 ¹ / ₂	1 ⁷ / ₈	6 ⁵ / ₈
2 × 2	12	9	2	7
3 × 2	17	9	2 ¹ / ₂	6 ¹³ / ₁₆
3 × 3	19	10	2 ¹ / ₂	7 ¹ / ₂
4 × 2	20	9	3	7
4 × 3	22 ¹ / ₂	10	3	7 ¹ / ₄
4 × 4	26	11	3	8

NOTE 1—1 in. = 25.4 mm.

FIG. 36 Straight Tees

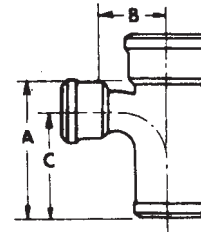

Size, in.	Weight, lb	A, in.	B, in.	C, in.
2 × 1 ¹ / ₂	11	8 ¹ / ₂	3 ¹ / ₂	6 ³ / ₄
2 × 2	12	9	3 ¹ / ₂	7
3 × 1 ¹ / ₂	16	8 ¹ / ₂	4	6 ³ / ₄
3 × 2	18	9	4	7
3 × 3	20	10	4	7 ¹ / ₂
4 × 1 ¹ / ₂	18	8 ¹ / ₂	4 ¹ / ₂	6 ³ / ₄
4 × 2	19	9	4 ¹ / ₂	7
4 × 3	26	10	4 ¹ / ₂	7 ¹ / ₂
4 × 4	28	11	4 ¹ / ₂	8
6 × 2	31	9	5 ¹ / ₂	7
6 × 3	33	10	5 ¹ / ₂	7 ¹ / ₂
6 × 4	35	11	5 ¹ / ₂	8
6 × 6	50	13	5 ¹ / ₂	9
8 × 4	62	10 ⁵ / ₈	6 ¹ / ₄	8
8 × 6	65	14 ¹ / ₂	6 ⁵ / ₈	10 ¹ / ₂
8 × 8	113	19	6 ⁵ / ₈	13 ¹ / ₂
10 × 6	130	14 ¹ / ₄	7 ⁵ / ₈	10 ¹ / ₂
10 × 10	180	21	7 ³ / ₄	14 ¹ / ₂
12 × 8	187	19	8 ³ / ₄	13 ¹ / ₂

NOTE 1—1 in. = 25.4 mm.

FIG. 37 Sanitary T Branches

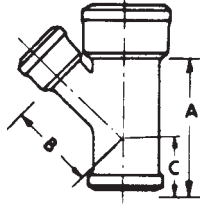
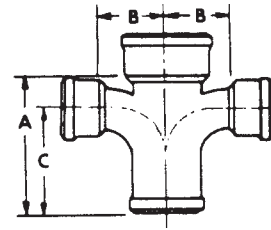

TABLE 3 Continued

Size, in.	Weight, lb	A, in.	B, in.	C, in.
2 × 1½	11	8⅝	4⅜	4⅜
2 × 2	12	9	4¼	4¾
3 × 1½	16	8⅝	5¼	3⅞
3 × 2	17	9	5	4¾
3 × 3	21	10½	5½	5
4 × 1½	17	9⅞	5¼	3⅞
4 × 2	21	9	5¾	3⅞
4 × 3	26	10½	6¼	4½
4 × 4	30	12	6¾	4½
6 × 2	28	9	7⅞	2⅞
6 × 3	35	10½	7⅞	3½
6 × 4	45	12¼	8¼	4¼
6 × 6	60	14¾	9⅞	5¼
8 × 2	60	16⅞	9	4½
8 × 3	63	12⅞	9	3¾
8 × 4	65	13½	10	4½
8 × 6	79	16½	11	6⅞
8 × 8	117	19½	12¼	7¼
10 × 4	160	13½	11½	3½
10 × 6	165	16⅞	13½	3⅞
10 × 8	170	19¾	14⅞	4⅞
10 × 10	180	22½	15	7⅞
12 × 4	173	18¼	15⅞	4½
12 × 6	196	18¼	16½	4½
12 × 8	200	23⅞	15½	5
12 × 10	275	27	19½	6
12 × 12	288	25½	18⅞	7¼
15 × 15	455	32⅞	22¾	8⅞

NOTE 1—1 in. = 25.4 mm.

FIG. 38 Sanitary Y Branches



Size, in.	Weight, lb	A, in.	B & B, in.	C, in.
2 × 1½	14	8½	7	6¾
2 × 2	16	9	7	7
3 × 1½	15	8½	8	6¾
3 × 2	17	9	8	7
3 × 3	22	10	8	7½
4 × 1½	18	8½	9	6¾
4 × 2	21	9	9	7
4 × 3	24	10	9	7½
4 × 4	37	11	9	8
6 × 3	50	10	11	7½
6 × 4	46	11	11	8
6 × 6	58	13	11	9
8 × 6	80	14½	13¼	10½
8 × 8	113	19	6⅞	13½

NOTE—1 in. = 25.4 mm.

FIG. 39 Double-Branch Sanitary Tee

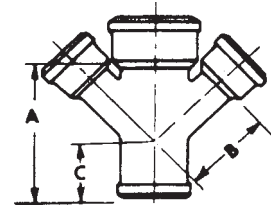

Size, in.	Weight, lb	A, in.	B, in.	C, in.
2 × 1½	14	8⅝	4⅜	4⅜
2 × 2	15	9	4¼	4¾
3 × 1½	19	8⅝	5¼	3⅞
3 × 2	20	9	5	4¾
3 × 3	28	10½	5½	5
4 × 1½	21	9⅞	5¼	3⅞
4 × 2	23	9	5¾	3⅞
4 × 3	26	10½	6¼	4½
4 × 4	33	12	6¾	5¼
6 × 2	31	9	7⅞	2⅞
6 × 3	46	10½	7⅞	3½
6 × 4	52	12	8⅞	4¼
6 × 6	65	14¾	9⅞	5¼
8 × 4	71	13½	10	10½
8 × 6	86	16½	11	6⅞

NOTE 1—1 in. = 25.4 mm.

FIG. 40 Double-Branch Sanitary Y

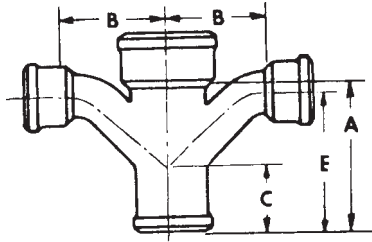
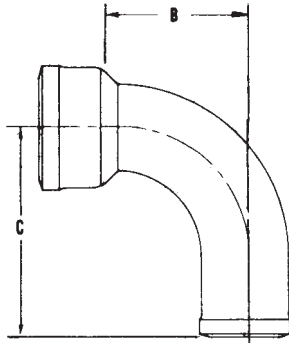

TABLE 3 Continued

Size, in.	Weight, lb	A, in.	B and B, in.	C, in.	E, in.
2 × 1½	15	8⅝	9¼	4⅜	7⅜
2 × 2	17	9	10½	4¾	8¼
3 × 1½	17	8⅝	10¼	3⅞	7⅜
3 × 2	22	9	11½	4⅜	8⅜
3 × 3	27	10½	13	5	9⅞
4 × 1½	24	9⅝	11¾	3⅞	8⅞
4 × 2	24	9	12½	3⅞	8⅜
4 × 3	28	10½	14	4½	9⅞
4 × 4	40	12	15½	5¼	10⅜
6 × 3	45	10½	16	3½	9⅞
6 × 4	57	12	17½	4¼	10⅜
6 × 6	83	15	20½	5¼	13⅞

NOTE 1—1 in. = 25.4 mm.

FIG. 41 Double-Branch Sanitary Combination Y and 1/8 Bend (T-Y)



Size, in.	Weight, lb	B, in.	C, in.
2	11	5¼	8
3	20	6	9
4	25	6½	10

NOTE 1—1 in. = 25.4 mm.

FIG. 42 Short-Sweep Quarter Bends

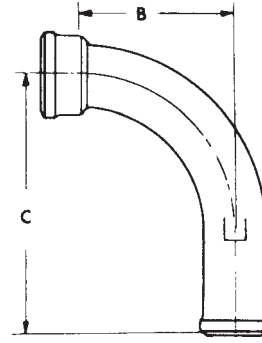

Size, in.	Weight, lb	B, in.	C, in.
2	14	8½	12
3	24	9	12½
4	29	9½	13
6	47	10½	14
8	98	11⅝	15

NOTE 1—1 in. = 25.4 mm.

FIG. 43 Long-Sweep Quarter Bends

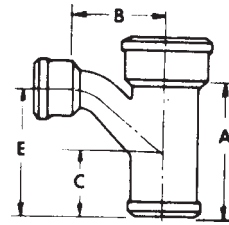

Size, in.	Weight, lb	A, in.	B, in.	C, in.	E, in.
2 × 1½	11	8⅝	4⅜	4⅜	7⅜
2 × 2	13	9	5¼	4¾	8¼
3 × 1½	14	8⅝	5⅞	3⅞	7⅜
3 × 2	18	9	5¾	4⅜	8⅜
3 × 3	24	10½	6½	5	9⅞
4 × 1½	17	9⅝	5⅞	3⅞	8⅞
4 × 2	21	9	6¼	3⅞	8⅜
4 × 3	23	10½	7	4½	9⅞
4 × 4	31	12	7¾	5¼	10⅜
6 × 2	33	9	7¼	2⅞	8⅜
6 × 3	37	10½	8	3½	9⅞
6 × 4	47	12	8¾	4¼	10⅜
6 × 6	63	15	10¼	5¼	13⅞
10 × 6	185	16¾	12½	4⅞	4⅞
10 × 8	192	21⅝	15⅞	6½	18½

NOTE 1—1 in. = 25.4 mm.

FIG. 44 Sanitary Combination Y and 1/8 Bend (T-Y)

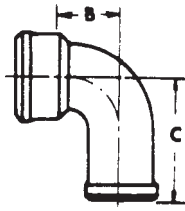
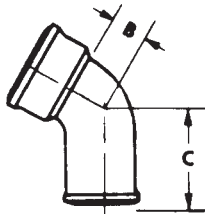

TABLE 3 Continued

Size, in.	Weight, lb	B, in.	C, in.
2	9	3½	7
3	16	4	7½
4	20	4½	8
6	36	5½	9
8	54	6⅞	10
10	116	8⅝	12
12	195	10⅝	14

NOTE 1—1 in. = 25.4 mm.
FIG. 45 Quarter Bends



Size, in.	Weight, lb	B, in.	C, in.
2	8	2¼	5¾
3	11	2½	6
4	15	2⅜	6⅝
6	27	3⅞	6⅞
8	71	4⅞	9

NOTE 1—1 in. = 25.4 mm.
FIG. 46 Sixth Bends

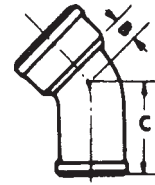

Size, in.	Weight, lb	B, in.	C, in.
2	7	1¾	5¼
3	13	1⅝	5⅞
4	16	2⅜	5⅞
6	25	2⅞	6⅞
8	46	3⅞	8⅜
10	95	4¼	9¼
12	132	5	9⅝

NOTE 1—1 in. = 25.4 mm.
FIG. 47 Eighth Bends

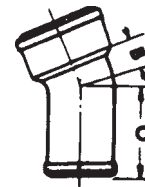

Size, in.	Weight, lb	B, in.	C, in.
2	6	1⅞	4⅞
3	8	1⅜	4⅞
4	11	1⅝	4⅞
6	21	1½	5
8	44	2⅞	7⅞
10	80	2	6⅞

NOTE 1—1 in. = 25.4 mm.
FIG. 48 Sixteenth Bends

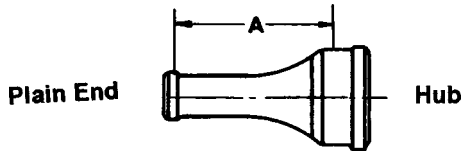
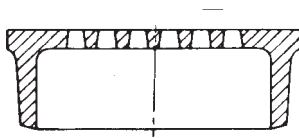

TABLE 3 Continued

Size, in.	Weight, lb	A, in.
2 × 3	9	9
2 × 4	13	9
2 × 6	17	9
3 × 4	17	9
3 × 6	16	9
4 × 6	17	9
4 × 8	33	11 ⁵ / ₈
6 × 8	50	11 ⁷ / ₈
8 × 10	85	16

NOTE 1—1 in. = 25.4 mm.

FIG. 49 Sanitary Increasers



Size, in.	Weight, lb
2	2 ¹ / ₂
3	3
4	5
6	10
8	18

NOTE 1—1 in. = 25.4 mm.

FIG. 50 Hub Strainers

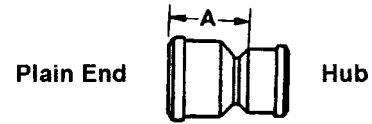

Size, in.	Weight, lb	A, in.
3 × 1 ¹ / ₂	6	5
3 × 2	7	5
4 × 1 ¹ / ₂	7	5
4 × 2	9	5
4 × 3	11	5
6 × 2	12	5
6 × 3	13	5
6 × 4	14	5
8 × 4	22	6
8 × 6	25	6
10 × 6	39	6
10 × 8	51	6
12 × 6	55	6 ¹ / ₂
12 × 8	65	6
12 × 10	83	6
15 × 6	79	6
15 × 12	109	6

NOTE 1—1 in. = 25.4 mm.

FIG. 51 Sanitary Reducers

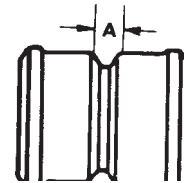

Size, in.	Weight, lb	A, in.
2	6 ¹ / ₂	1
3	9	1
4	12	1
6	18	1
8	40	2
10	82	2

NOTE 1—1 in. = 25.4 mm.

FIG. 52 Double Hubs

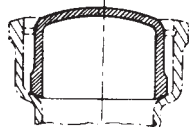
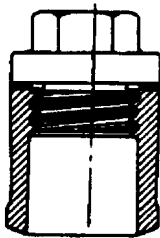

TABLE 3 Continued

Size, in.	Weight, lb
2	2
3	3
4	5
6	10
8	17
12	56

NOTE 1—1 in. = 25.4 mm.

FIG. 53 Pipe Plugs



Size, in.	Weight, lb
2	3½
3	6½
4	11
6	14
8	26
10	39

NOTE 1—1 in. = 25.4 mm.

FIG. 54 Cleanout Plugs

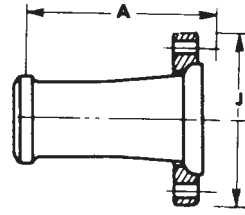

Size, in.	Weight, lb	A, in.	J, in.
2	5	5¾	6
3	11	7	7½
4	12	8	9
6	22	9½	11
8	44	10¾	13½

NOTE 1—1 in. = 25.4 mm.

FIG. 55 Adapter—Plain-End and Split Flange

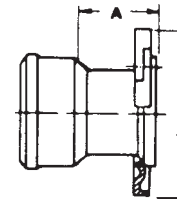

Size, in.	Weight, lb	A, in.	J, in.
2	5	2½	6
3	7	2½	7½
4	12	2¾	9
6	16	3	11
8	36	3½	13½

NOTE 1—1 in. = 25.4 mm.

FIG. 56 Adapter—Hub and Split Flange

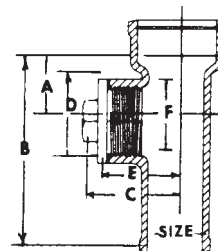

Size, in.	Weight, lb	A, in.	B, in.	C, in.	D, in.	E, in.	F, in.
2	12	2½	9	3 ¹³ / ₁₆	3 ⁵ / ₈	3 ¹ / ₁₆	2 ⁷ / ₈
3	22	2 ⁷ / ₈	10	5	4 ⁵ / ₈	4 ¹ / ₄	3 ¹³ / ₁₆
4	29	3 ³ / ₁₆	11	5 ⁷ / ₁₆	5 ⁵ / ₈	4 ¹ / ₂	4 ¹³ / ₁₆

NOTE 1—1 in. = 25.4 mm.

FIG. 57 Combination Cleanout and Test Tees

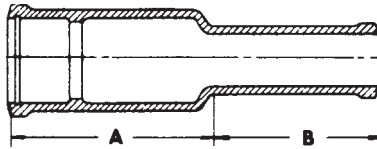
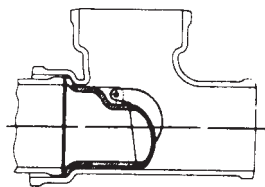

TABLE 3 Continued

Plate No.	Size, in.	Weight, lb	A, in.	B, in.
5045	2	11	7 ³ / ₄	6 ¹ / ₂
5070	3	17	8 ³ / ₈	7 ³ / ₈
5095	4	21	9 ¹ / ₈	7 ⁷ / ₈
5144	6	37	9 ¹ / ₈	7 ⁷ / ₈

NOTE 1—1 in. = 25.4 mm.

FIG. 58 Insertable Joints



Size, in.

- 3
- 4
- 6
- 8

NOTE 1—1 in. = 25.4 mm.

FIG. 59 Backwater Valves

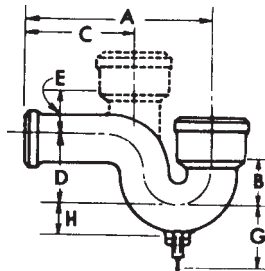

Size, in.	Without Vent Weight, lb	Hub Vent Weight, lb	A, in.	B, in.	C, in.	D, in.	E, in.	G, in.	H, in.	Vent, in.
2	12	16	11	3	6 ¹ / ₄	4 ¹ / ₂	2 ¹ / ₄	3 ¹³ / ₁₆	1 ⁵ / ₈	2
3	25	32	12 ¹ / ₂	4 ¹ / ₄	6 ¹ / ₄	5 ¹ / ₂	3	4 ¹ / ₂	2 ⁵ / ₁₆	3
4	37	45	14	5 ¹ / ₂	7	6 ¹ / ₂	3 ¹ / ₄	5 ³ / ₁₆	3	4
6	68	80	17	8 ¹ / ₂	8	8 ¹ / ₂	4	6 ¹ / ₂	3 ¹⁵ / ₁₆	4

NOTE 1—Depth of seal on all traps shall be 2¹/₂ in.

NOTE 2—1 in. = 25.4 mm.

FIG. 60 Sanitary P Traps

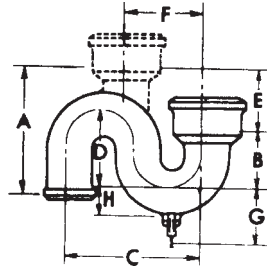

TABLE 3 Continued

Size, in.	Without Vent, Weight, lb	Hub Vent, Weight, lb	A, in.	B, in.	C, in.	D, in.	E, in.	F, in.	G, in.	H, in.	Vent, in.
2	16	18	9 ¹ / ₄	3	8	4 ¹ / ₂	3 ³ / ₄	4 ³ / ₄	3 ¹³ / ₁₆	1 ⁵ / ₈	2
3	24	29	10 ¹ / ₂	4 ¹ / ₄	10	5 ¹ / ₂	4 ¹ / ₄	6 ¹ / ₄	4 ¹ / ₂	2 ⁵ / ₁₆	3
4	33	39	11 ¹ / ₄	5 ¹ / ₂	12	6 ¹ / ₂	4 ¹ / ₄	7	5 ³ / ₁₆	3	4
6	82	89	14	8 ¹ / ₂	16	8 ¹ / ₂	5	9	6 ¹ / ₂	3 ¹⁵ / ₁₆	4

NOTE 1—Depth of seal on all traps shall be 2¹/₂ in.

NOTE 2—1 in. = 25.4 mm.

FIG. 61 Sanitary S Traps

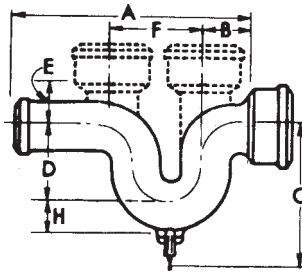

Size, in.	Without Vent, Weight, lb	Single Hub Vent, Weight, lb	Double Hub Vent, Weight, lb	A, in.	B, in.	D, in.	E, in.	F, in.	G, in.	H, in.	Vent, in.
2	14	17	22	13 ¹ / ₂	2 ¹ / ₂	4 ¹ / ₂	2 ¹ / ₂	5 ¹ / ₄	8 ⁵ / ₁₆	1 ⁵ / ₈	2
3	29	36	42	15 ¹ / ₂	3	5 ¹ / ₂	3 ¹ / ₄	6 ¹ / ₄	10	2 ⁵ / ₁₆	3
4	41	49	57	17 ¹ / ₂	3 ¹ / ₂	6 ¹ / ₂	3 ¹ / ₂	7 ¹ / ₄	11 ¹¹ / ₁₆	3	4
6	78	87	168	21 ¹ / ₂	4 ¹ / ₂	8 ¹ / ₂	4 ¹ / ₄	8 ¹ / ₄	15	3 ¹⁵ / ₁₆	4
8	162	165	208	26 ⁷ / ₈	5 ¹ / ₂	11	3 ³ / ₈	12	18 ⁷ / ₁₆	5 ¹ / ₄	6
10	330	334	346	31 ⁷ / ₈	7 ¹ / ₈	13	5 ⁵ / ₈	16	22 ¹ / ₄	6 ¹¹ / ₁₆	6

NOTE 1—Single hub vent is located on the inlet side. Depth of seal on 8 and 10-in. traps is 3 in. All others 2¹/₂ in.

NOTE 2—1 in. = 25.4 mm.

FIG. 62 Sanitary Running Traps

ASME A 861 - 04

- 1 (without flashing ring)
- 2 (with flashing ring)

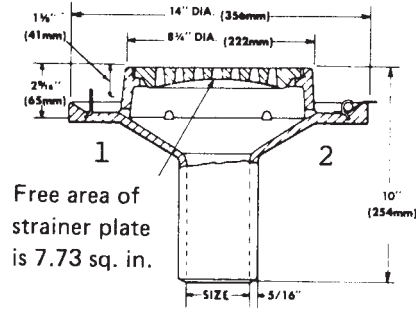

TABLE 3 Continued

Plate No.	Outlet Size, in.	Weight, lb
1	2, 3, 4 and 6	45
2	2, 3, 4 and 6	45
3	2, 3, 4 and 6	53
4	2, 3, 4 and 6	53
5	2, 3, 4 and 6	41
6	2, 3, 4 and 6	42
7	2, 3, 4 and 6	48
8	2, 3, 4 and 6	49

NOTE 1—1 in. = 25.4 mm.

FIG. 63 Outside Caulk

- 3 (without flashing ring)
- 4 (with flashing ring)

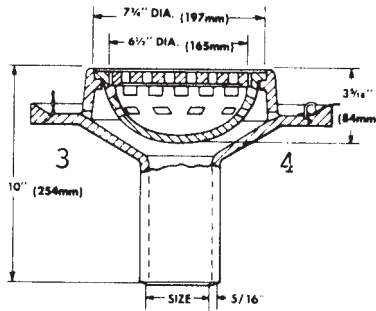
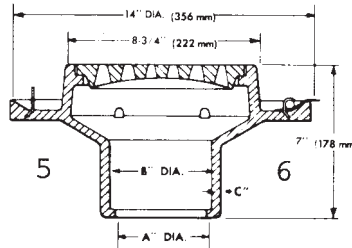

Plate No.	Size, in.	A, in.	B, in.	C, in.
5, 6, 7, 8	2	2 7/8	3 1/2	5/16
	3	3 7/8	4 1/2	5/16
	4	4 7/8	5 1/2	3/8
	6	7	7 3/4	3/8

NOTE 1—1 in. = 25.4 mm.

FIG. 64 Outside Caulk with Basin

- 5 (without flashing ring)
- 6 (with flashing ring)
- 7 *(with sediment basin and without flashing ring)
- 8 *(with sediment basin and with flashing ring)



NOTE 1—1 in. = 25.4 mm.
FIG. 65 Inside Caulk

Plates 1, 2

Plates 3, 4
 (With Sediment Basin)

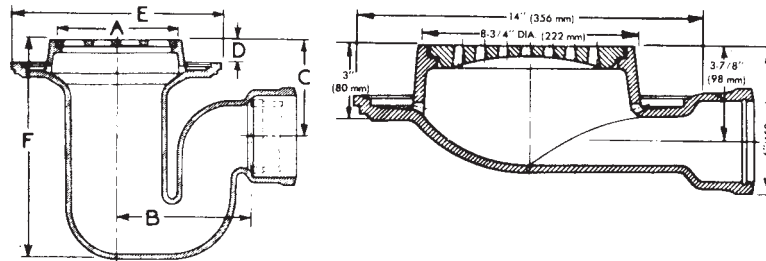

TABLE 3 *Continued*

Plate No.	Outlet Size, in.	Weight, lb
1	3	70
2	4	73
3	2	37
4	2	45

Plate No.	Size, in.	A, in.	B, in.	C, in.	D, in.	E, in.	F, in.
1	3	8	9	5 ⁷ / ₈	1 ¹ / ₂	14	14 ¹ / ₂
2	4	8	9	6 ³ / ₈	1 ¹ / ₂	14	14 ¹ / ₂

NOTE 1—1 in. = 25.4 mm.
FIG. 66 Floor Drains

With Flashing Ring

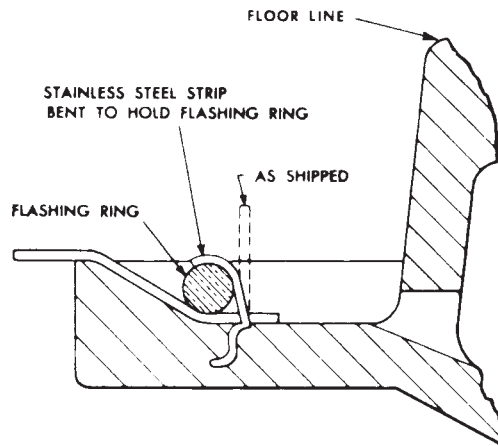
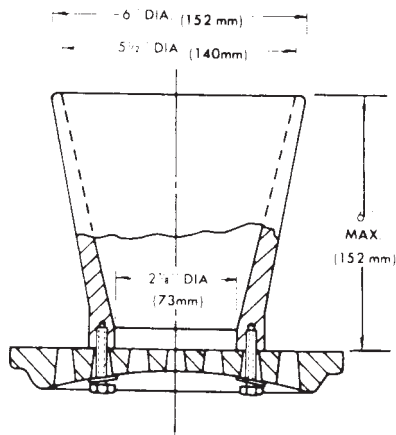

FIG. 67 Method of Installation



NOTE 1—1 in. = 25.4 mm.

FIG. 68 Floor Drain Funnel Attachment

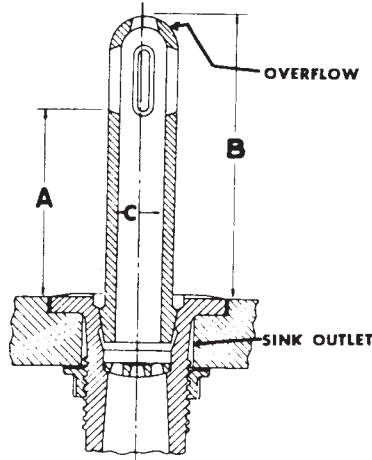

TABLE 3 Continued

Plate No.	A, in. ^A	B, in. ^A	C, in.
1	2	4 ¹ / ₈	1
2	4	6 ¹ / ₈	1
3	6	8 ¹ / ₈	1
4	8	10 ¹ / ₈	1
5	0	2 ¹ / ₈	1

^ADimensions A and B will vary depending upon the sink strainer in which overflow is placed, depth of counterbars, and so forth. Dimension B is given only as a guide.

NOTE 1—1 in. = 25.4 mm.

FIG. 69 No. 1, 2, 3, 4, and 5 Overflows

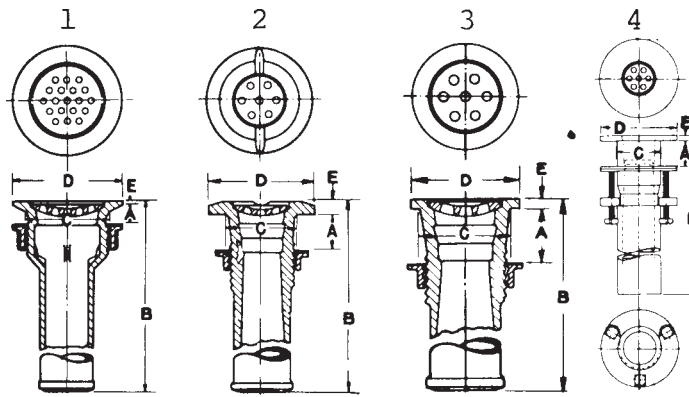

Plate No.	Size, in.	A, in.	B, in.	C, in.	D, in.	E, in.
1	1½ or 2	¾ to 1¼	10	3½	4¾	1/8
2	1½ or 2	1 to 2	10	2½	3¾	7/16
3	1½ or 2	1 to 2	10	2½	3	¼
4	1½	0 to 2	10¼		3 ⁵ / ₁₆	¼

NOTE 1—Furnished with flat loose strainer plates.

NOTE 2—1 in. = 25.4 mm.

FIG. 70 Sink Outlet

Standard traps carried in stock are made with cleanouts, as illustrated.

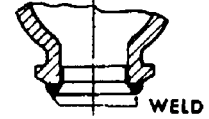
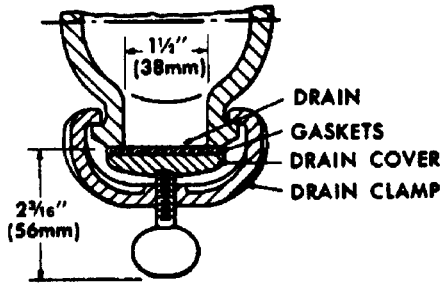

TABLE 3 Continued

Size, in.	Diameter of Drain, in.	A, in.
Under 6	1 1/2	2 3/16
6 and over	2 1/4	2 9/16

NOTE 1—Traps can be supplied without cleanouts, as shown in the figure.

NOTE 2—1 in. = 25.4 mm.

FIG. 71 Detailed Cross Section of Cleanout

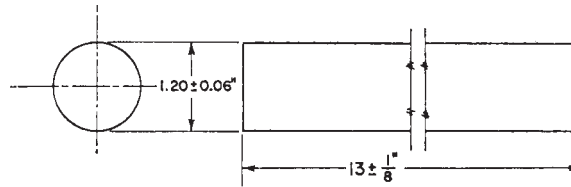

Metric Equivalents				
in.	0.06	1/8	1.20	13
mm	1.5	3.2	130.5	330.2

NOTE 1—It is recommended that the casting be mold-cooled to below 1000°F (540°C) before shakeout, and that the test bars be stress-relieved before transverse testing.

FIG. 72 Transverse Bend Test Bar Dimensions

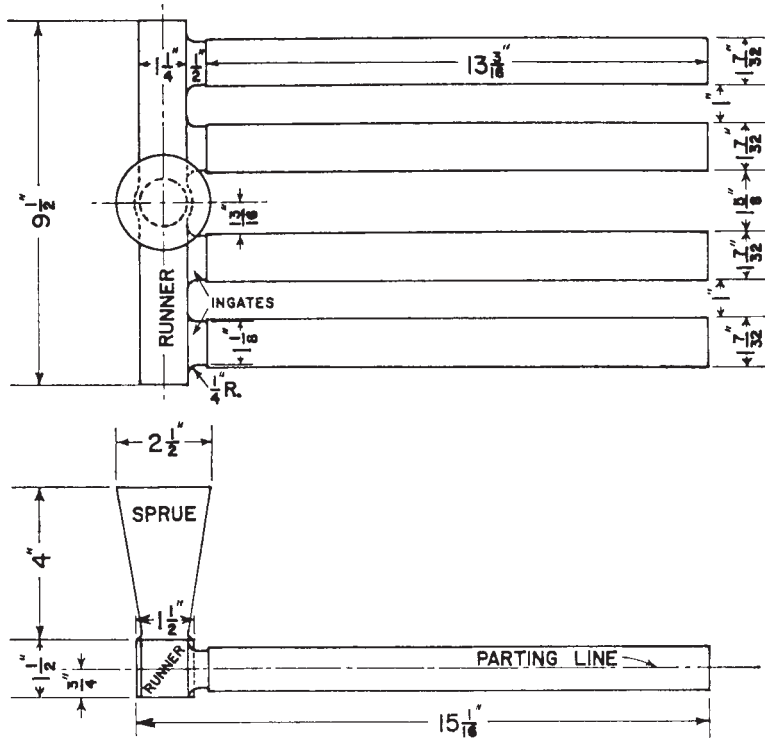

TABLE 3 Continued

Metric Equivalents

in.	1/4	1/2	3/4	13/16	1	1 1/8	1 7/32	1 1/4	1 1/2	1 5/8	2 1/2	9 1/2	13 3/16	15 1/16
mm	6.4	12.7	19.0	20.6	25.4	28.6	31.0	31.8	38.1	41.3	63.5	241.3	335.0	382.6

FIG. 73 Suggested Pattern for Transverse Bend Test Bar, Cast Horizontally, 1.20 in. (30.5 mm) in Diameter

ASTM International takes no position respecting the validity of any patent rights asserted in connection with any item mentioned in this standard. Users of this standard are expressly advised that determination of the validity of any such patent rights, and the risk of infringement of such rights, are entirely their own responsibility.

This standard is subject to revision at any time by the responsible technical committee and must be reviewed every five years and if not revised, either reapproved or withdrawn. Your comments are invited either for revision of this standard or for additional standards and should be addressed to ASTM International Headquarters. Your comments will receive careful consideration at a meeting of the responsible technical committee, which you may attend. If you feel that your comments have not received a fair hearing you should make your views known to the ASTM Committee on Standards, at the address shown below.

This standard is copyrighted by ASTM International, 100 Barr Harbor Drive, PO Box C700, West Conshohocken, PA 19428-2959, United States. Individual reprints (single or multiple copies) of this standard may be obtained by contacting ASTM at the above address or at 610-832-9585 (phone), 610-832-9555 (fax), or service@astm.org (e-mail); or through the ASTM website (www.astm.org).