



Designation: A 888 – 98^{ε1}

Standard Specification for Hubless Cast Iron Soil Pipe and Fittings for Sanitary and Storm Drain, Waste, and Vent Piping Applications¹

This standard is issued under the fixed designation A 888; the number immediately following the designation indicates the year of original adoption or, in the case of revision, the year of last revision. A number in parentheses indicates the year of last reapproval. A superscript epsilon (ε) indicates an editorial change since the last revision or reapproval.

^{ε1} NOTE—Note 1 was added editorially in September 1998.

1. Scope

1.1 This specification covers cast iron soil pipe and fittings for use in gravity flow applications. It establishes standards covering material, principal dimensions, and dimensional tolerances for hubless cast iron soil pipe and fittings. These pipe and fittings are not intended for pressure applications, as the selection of the proper size for sanitary drain, waste, vent, and storm drain systems allows free air space for gravity drainage.

1.2 This specification covers pipe and fittings of the following patterns and applies to any other patterns that conform with the requirements given herein.²

1.2.1 Lengths:

	Figures
EDP Identification Numbers for Hubless Pipe	1
10 ft (3.0 m) in sizes 1½, 2, 3, 4, 5, 6, 8, 10, 12, and 15 inch.	1, 2
Method of Specifying Fittings	3

1.2.2 Fittings:

Quarter Bend	4
Quarter Bend, Reducing	5
Quarter Bend, With Side Opening	6
Quarter Bend, With Heel Opening	7
Quarter Bend, Tapped	8
Quarter Bend, Double	9
Quarter Bend, Long	10
Short Sweep	11
Long Sweep	12
Long Sweep, Reducing	13
Fifth Bend	14
Sixth Bend	15
Eighth Bend	16
Eighth Bend Long	17
Sixteenth Bend	18
Sanitary Tee	19
Sanitary Tee With Side Opening	20
Sanitary Tee With 2 in. Side Opening R or L/R and L	21

Sanitary Tee, New Orleans Special With Side Opening	22
Sanitary Tee With 45° Side Openings and New Orleans	23
Sanitary Special Tee Tapped	24
Sanitary Tapped Tee, Horizontal Twin	25
Sanitary Tapped Tee, Double Vertical	26
Y Branch	27
Y Branch, Double	28
Y Branch, Upright	29
Upright Y Wide Center Florida Special	30
Y Branch, Combination ¼ Bend	31
Y Branch, Combination ¼ Bend Double	32
Sanitary Cross	33
Sanitary Cross With Side Opening	34
Sanitary Cross, New Orleans, With Side Openings	35
Sanitary Cross, New Orleans, With 45° Special and Regular Side Openings	36
Sanitary Cross, Tapped	37
Test Tee	38
Tapped, Extension Piece	39
Increaser-Reducer	40
Increaser-Reducer, Short	41
Tapped Adapter	42
Blind Plug	43
Iron Body Cleanout-Tapped	44
P Trap	45
P Trap, Long	46
P Trap, Long-Tapped	47
P Trap, Deep Seal	48
P Trap, Reducing	49
P Trap, With Primer	50
P Trap, With Tapped Inlet	51
Hub Adapter	52
Tapped Inlet, Double	53
Modified Combination Wye and ¼ Bend, Double	54
Modified Combination Wye and ¼ Bend, Double, Extended	55
Regular or Extended Left or Right Regular or Extended Double	56
Regular or Extended Left or Right Regular or Extended Double	57
Two-Way Cleanout	58
Twin Cleanout	59
Closet Bend, Regular and Reducing	60
Closet Flange	61
Tapping Bosses	62

1.3 The values stated in inch-pound units shall be regarded as the standard. The values given in parentheses shall be for information only.

NOTE 1—The text of this standard references notes and footnotes which provide explanatory material. These notes and footnotes (excluding those

¹ This specification is under the jurisdiction of ASTM Committee A-4 on Iron Castings and is under the direct responsibility of Subcommittee A04.12 on Pipes and Tubes.

Current edition approved Apr. 10, 1998. Published August 1998. Originally published as A 888 – 90. Last previous edition A 888 – 95.

² Reprinted with permission from Cast Iron Soil Pipe Institute.

in tables and figures) shall not be considered as requirements of the standard.

2. Referenced Documents

2.1 *ASTM Standards:*

- A 48 Specification for Gray Iron Castings³
- A 438 Test Method for Transverse Testing of Gray Cast Iron³
- A 644 Terminology Relating to Iron Castings³
- E 8 Test Methods for Tension Testing of Metallic Materials⁴
- E 23 Test Methods for Notched Bar Impact Testing of Metallic Materials⁴

2.2 *Federal Standard:*

Fed. Std. No. 123 Marking for Shipment (Civil Agencies)⁵

2.3 *Military Standard:*

MIL-STD-129 Marking for Shipment and Storage⁵

2.4 *ANSI Standard:*

B1.20.1 Pipe Threads⁶

2.5 *NIST Document:*

*Handbook 28, Screw Thread Standards for Federal Services*⁷

2.6 *Other Documents:*

- Uniform Freight Classification Rules⁸
- National Motor Freight Classification Rules⁹
- Cast Iron Soil Pipe Institute (CISPI) Specification 301¹⁰

3. Terminology

3.1 *Abbreviations:*

- AC—above center
- ADAPTR—adapter
- &—and
- ASSY—assembly
- BD—bend
- CARL—Carlson
- CF—Carlson fitting
- CLO—closet
- CO—cleanout
- COMB—combination
- CRS—cross
- DB—double
- DBL—double
- EXT—extended, extension
- F—figure
- FER—ferrule
- FLNG—flange

- FTG—fitting
- HI—high
- HOR—horizontal
- INC—increaser, increasing
- L—left hand
- L/—less
- LG—long
- LH—left hand
- LNG—long
- /MAIN—on main
- MN—on main
- NO—New Orleans
- R—right hand
- RAD—radius
- RED—reducer, reducing
- REV—revent
- RH—right hand
- SAN—sanitary
- SD—side
- SL & NOTCH—slotted and notched
- SO—side openings
- ST—sanitary tap
- T—tee
- TAP—tap, tapped
- TOT—tap on top
- TP—tap, tapped
- V—vent
- VERT—vertical
- W/—with
- Y—wye

4. Ordering Information

4.1 Ordering for material under this specification shall include as a minimum the following information:

- 4.1.1 ASTM designation (A 888) and year of issue,
- 4.1.2 American Supply Association (ASA) code and item number, or description of the castings by table number (see Table 1 and Figs. 1-62) or by the manufacturer’s catalog number,
- 4.1.3 Diameter of pipe and size and shape of fittings,
- 4.1.4 Quantity,
- 4.1.5 Mechanical tests, if required,

TABLE 1 EDP Identification Numbers for Hubless Pipe

NOTE 1— When ordering by these EDP numbers, be sure to include the check (✓) digit following the item number (022 0126 7). This check digit is verification of the group and item number you select.

Manufacturer's Item	Code			Description ^A
	Group	Item No.	✓	
Hubless pipe (see Fig. 1.)	022	0156	4	10 ft (3 m) length 1½
		0158	0	2½
		0160	6	3
		0162	2	4
		0164	8	5
		0168	9	6
		0170	5	8
		0171	3	10
		0172	7	12
		0173	1	15

^A EDP numbers for fittings will appear in each of the respective tables.

³ Annual Book of ASTM Standards, Vol 01.02.
⁴ Annual Book of ASTM Standards, Vol 03.01.
⁵ Available from Standardization Documents, Order Desk, Building 4, Section D, 700 Robbins Ave., Philadelphia, PA 19111-5094, Attn: NPODS.
⁶ Available from the American National Standards Institute, 11 W. 42nd St., 13th Floor, New York, NY 10036.
⁷ Available from National Institute of Standards and Technology, U.S. Department of Commerce, Gaithersburg, MD 20899.
⁸ Available from the Uniform Classification Commission, Room 1106, 222 S. Riverside Plaza, Chicago, IL 60606.
⁹ Available from National Motor Freight Inc., 1616 P. St., N. W., Washington, DC 20036.
¹⁰ Available from Cast Iron Soil Pipe Institute, 5959 Shallowford Rd., Chattanooga, TN 37421.

- 4.1.6 Certification requirements, if desired,
- 4.1.7 Special packaging and marking requirements (see Section 13), and
- 4.1.8 Supplementary requirements, if desired.

5. Materials and Manufacture

5.1 The pipe and fittings shall be iron castings suitable for installation and service for sanitary storm drain, waste, and vent piping applications. They shall meet all applicable requirements and tests given herein.

5.2 The castings shall be made of cast iron, produced by an established commercial method that provides adequate control over chemical and mechanical properties. Cast iron is a generic term for a series of alloys as defined in Terminology A 644, and it includes gray iron as well as ductile iron. The castings shall be sound, true to pattern, and of compact close grain that permits drilling and cutting by ordinary methods. The interior surface shall be reasonably smooth and free from defects that would make the castings unfit for the use for which they are intended.

6. Mechanical Properties

6.1 *Mechanical Tests for Gray Iron*—When requested, tests shall be made to determine mechanical properties of the gray iron used in the manufacture of gray iron soil pipe and fittings. Either transverse (flexure) test bars or tension test specimens shall be employed.

6.1.1 *Transverse Bend Test*—The breaking load shall be not less than 1750 lb (7800 N), and the deflection at the point of application of the load shall be not less than 0.20 in. (5.1 mm).

6.1.2 *Tensile Strength Test*—The tensile strength shall be not less than 21 000 psi (145 MPa).

7. Dimensions and Permissible Variations

7.1 Pipe:

7.1.1 *Ends of Pipe*—The end of pipe shall be cast with or without a spigot bead. The pipe shall be cast in one piece.

7.1.2 *Dimensions of Pipe*—Pipe shall be 10 ft (3 m) long with the dimensions and tolerances specified in Fig. 1 and Fig. 2. (The laying length of pipe is the same as actual length.)

7.1.3 *Straightness of Pipe*—Pipe shall be straight to the extent that any deflections in the barrel for 10 ft (3 m) lengths, deflections in the barrel shall not exceed $\frac{5}{8}$ in. (16 mm).

7.2 Fittings:

7.2.1 *Dimensions of Fittings*—All fittings shall conform to the dimensions and tolerances specified in Fig. 1 and Fig. 2 as applicable. Fittings of the patterns specified herein shall conform to the applicable dimensions in Figs. 5-62, inclusive. Fittings not listed shall conform to Fig. 1 for wall thickness and dimension R for the minimum radius of any drain inlets that any such fittings provide.

7.2.2 *Ends of Fittings*—Ends shall have spigot beads as shown in Fig. 1 and Fig. 2. Positioning lugs shall be cast on fittings. These lugs shall be as described in Fig. 2.

7.2.3 *Pipe Threads*—Screw plugs and tapped openings in fittings shall have ANSI standard taper pipe threads. The threads shall be in accordance with ANSI Standard B 1.20.1 or with the National Institute for Standards and Technology Handbook 28, Screw Thread Standards for Federal Services, of the current issue.

7.2.4 Internal threads shall be chamfered at the entering end approximately to the major diameter of the thread, at an angle of approximately 45° with the axis of the thread for easy entrance in making a joint and for protection of the thread. The chamfer shall be concentric with the thread and shall be included in the measurement of the thread length.

8. Methods of Specifying Fittings

8.1 *Method of Specifying Sizes of Fittings of More than One Size*—The sizes shall be designated by the order of listing, as follows:

8.1.1 Branch and Tapped Fittings:

8.1.1.1 *Size of Run*—The run shall be that portion of the fitting which forms part of the main pipe line.

8.1.1.2 Size of Branch:

8.2 *Methods of Specifying Hand of Fittings with Side Inlets*—When placed in the position described below. If the side inlet appears on the right, it shall be a right-hand fitting; if on the left, it shall be a left-hand fitting.

8.2.1 *Branch Fittings*—The branch shall be placed toward the observer and the outlet end of the run lower than the branch.

8.3 The fitting illustrated in Fig. 3 has a right-hand inlet. Left-hand fittings have these openings on the side opposite to that shown. Inlets on fittings shall be made with or without spigot bead and positioning lug.

9. Coating

9.1 The pipe and fittings shall be furnished coated. The pipe and fittings shall be uniformly coated with a material suitable for the purpose that is adherent, not brittle, and without a tendency to scale. The coating shall be evenly and smoothly applied to all surfaces, except in threaded openings.

10. Test Methods

10.1 Gray Iron:

10.1.1 *Transverse Bend Test*—The transverse bend test shall be performed in accordance with the requirements of Test Method A 438. The test bar shall be 1.2 in. (30.5 mm) in diameter by 21 in. (533 mm) in length and loaded at a point midway between supports 18 in. (457 mm) apart.

10.1.2 *Tensile Strength Test*—Test bars shall be cast in accordance with the requirements of Specification A 48. The tensile strength shall be determined in accordance with Test Methods E 8, using specimen 2, Fig. 16, Standard Test Specimen for Cast Iron.

11. Inspection

11.1 *Inspection and Test by the Manufacturer*—Pipe and fittings shall be inspected by the manufacturer before shipment. On the sample pieces selected for inspection, the outside and inside diameter of the barrel and the outside diameter of the spigot end shall be checked by suitable gages.

12. Certification

12.1 Upon request of the purchaser, the manufacturer shall be prepared to certify that his product is in conformance with the requirements of this specification.

13. Product Marking

13.1 Each length of pipe and each fitting shall be plainly



marked with the country of origin and the manufacturer's name or registered trade-mark by which he can be readily identified after installation. The pipe shall be marked continuously on the barrel with a minimum of 0.75 in. (19 mm) lettering to begin not less than 1.50 in. (38 mm) from either end. On fittings, the marking shall not be located within the "W" dimension, as shown in Fig. 1. The marking shall be cast or stenciled on the pipe or be otherwise applied so as to be clear and legible. The marking shall be cast on fittings and shall be located away from the end so as not to interfere with proper joining upon installation.

14. Packaging and Package Marking

14.1 *Government Procurement*—Unless otherwise specified in the contract, the material shall be packaged in accordance with the supplier's standard practice, which will be acceptable to the carrier at lowest rates. Containers and packing shall comply with Uniform Freight Classification Rules or National Motor Freight Classification Rules. Marking for shipment of such material shall be in accordance with Fed. Std. No. 123 for civil agencies and MIL-STD-129 for military agencies.

SUPPLEMENTARY REQUIREMENTS

The following supplementary requirements shall be applied only when specified by the purchaser. Details of the supplementary requirements shall be agreed upon by the manufacturer and the purchaser. The specified tests shall be performed by the manufacturer prior to shipment of the castings.

S1. Leak Tests on Pipe

S1.1 Sample lengths of pipe shall be checked for leaks by subjecting them to an internal hydrostatic pressure of 20 psi (138 kPa).

S1.2 Samples shall be taken at substantially regular intervals in the course of production so as to be representative of the

material delivered and shall consist of at least 20 % of the lengths ordered in each size. For every sample that leaks, four or more additional samples shall be taken. Each additional sample shall be representative of the same material as that of the defective sample.

S1.3 Pipes that leak shall be rejected.

APPENDIXES

(Nonmandatory Information)

X1. ELECTRONIC DATA PROCESSING (EDP) NUMBERS

X1.1 Please take note that electronic data processing (EDP) numbers have been added. The EDP numbers indicated represent a new Uniform Industry Code adopted by the Cast Iron Soil Pipe Institute (CISPI) and the American Supply Association (ASA). A group designation prefix (022) is assigned to

hubless products, followed by the four digit identification assigned to individual items and a check digit. This system has been instituted to facilitate EDP control through distribution channels, and should now be used universally in ordering and specifying product items.

X2. PROCEDURES FOR SOIL SURVEY TESTS AND OBSERVATIONS AND THEIR INTERPRETATION TO DETERMINE WHETHER CAST IRON PIPE FOR WASTE WATER OR OTHER LIQUIDS REQUIRES POLYETHYLENE ENCASEMENT

X2.1 Scope

X2.1.1 In the appraisal of soil and other conditions that affect the corrosion rate of cast iron pipe, a minimum number of factors must be considered. They are outlined in the following sections. A method of evaluating and interpreting each factor and a method of weighting each factor to determine whether polyethylene encasement should be used are subsequently described.

X2.2 Earth Resistivity

X2.2.1 There are three methods for determining earth resistivity: four-pin, single-probe, and soil-box. In the field, a four-pin determination should be made with pins spaced at approximate pipe depth. This method yields an average of

resistivity from the surface to a depth equal to pin spacing. However, results are sometimes difficult to interpret where dry top soil is overlaid with wetter soils and where soil types vary with depth. The Wenner configuration is used in conjunction with a resistivity meter. For all-around use, a unit with a capacity of up to 10^4 ohms is suggested because of its versatility in permitting both field and laboratory testing in most soils.

X2.2.2 Because of the aforementioned difficulty in interpretation, the same unit may be used with a single probe that yields resistivity at the point of the probe. A boring is made into the subsoil so that the probe may be pushed into the soil at the desired depth.

X2.2.3 Inasmuch as the soil may not be typically wet, a

sample should be removed for resistivity determination, which may be accomplished with any one of several laboratory units that permits the introduction of water to saturation, thus stimulating saturated field conditions. Each of these units is used in conjunction with a soil resistivity meter.

X2.2.4 Interpretation of resistivity results is extremely important. To base an opinion on a four-pin reading with dry top soil averaged with wetter subsoil would probably result in an inaccurate premise. Only by reading the resistivity in soil at pipe depth can an accurate interpretation be made. Also, every effort should be made to determine the local situation concerning ground-water table, presence of shallow ground water, and approximate percentage of time the soil is likely to be water-saturated.

X2.2.5 With cast iron pipe, corrosion protection provided by products of corrosion is enhanced if there are dry periods during each year. Such periods seem to permit hardening or toughening of the corrosion scale or products, which then become impervious and serve as better insulators.

X2.2.6 In making field determinations of resistivity, temperature is important. The result obtained increases as temperature decreases. As the water in the soil approaches freezing, resistivity increases greatly, and, therefore, is not reliable. Field determinations under frozen soil conditions should be avoided. Reliable results under such conditions can be obtained only by collection of suitable subsoil samples for analysis under laboratory conditions at suitable temperature.

X2.2.7 *Interpretation of Resistivity*—Because of the wide variance in results obtained under the methods described, it is difficult specifically to interpret any single reading without knowing which method was used. It is proposed that interpretation be based on the lowest reading obtained with consideration being given to other conditions, such as normal moisture content of the soil in question. Because of the lack of exact correlation between experiences and resistivity, it is necessary to assign ranges of resistivity rather specific numbers. In Table X2.1, points are assigned to various ranges of resistivity. These points, when considered along with points assigned to other soil characteristics, are meaningful.

X2.3 pH

X2.3.1 In the pH range from 0.0 to 4.0, the soil serves well as an electrolyte, and total acidity is important. In the pH range from 6.5 to 7.5, soil conditions are optimum for sulfate reduction. In the pH range from 8.5 to 14.0, soils are generally quite high in dissolved salts, yielding a low soil resistivity.

X2.3.2 In testing pH, glass and reference electrodes are pushed into the soil sample and a direct reading is made following suitable temperature setting on the instrument. Normal procedures are followed for standardization.

X2.4 Oxidation-Reduction (Redox) Potential

X2.4.1 The oxidation-reduction (redox) potential of a soil is significant because the most common sulfate-reducing bacteria can live only under anaerobic conditions. A redox potential greater than + 100 mV shows the soil to be sufficiently aerated so that it will not support sulfate reducers. Potentials of 0 to + 100 mV may or may not indicate anaerobic conditions under which sulfate reducers thrive. This test also is accom-

TABLE X2.1 Soil-Test Evaluation^A

Soil Characteristics	Points
Resistivity, ohm-cm (based on single probe at pipe depth or water-saturated soil-box):	
<700	10
700–1000	8
1000–1200	5
1200–1500	2
1500–2000	1
>2000	0
pH:	
0–2	5
2–4	3
4–6.5	0
6.5–7.5	0 ^B
7.5–8.5	0
>8.5	3
Redox potential:	
> + 100 mV	0
+ 50 tp + 100 mV	3.5
0 to + 50 mV	4
Negative	5
Sulfides:	
Positive	3.5
Trace	2
Negative	0
Moisture:	
Poor drainage, continuously wet	2
Fair drainage, generally moist	1
Good drainage, generally dry	0

^A Ten points = corrosive to cast iron pipe; protection indicated.

^B If sulfides are present and low or negative redox potential results are obtained, three points shall be given for this range.

plished using a portable pH meter, with platinum and reference electrodes inserted into the soil sample, which permits a reading of potential between the two electrodes. It should be noted that soil samples removed from a boring or excavation can undergo a change in redox potential on exposure to air. Such samples should be tested immediately on removal from the excavation. Experience has shown that heavy clays, muck, and organic soils are often anaerobic, and these soils should be regarded as potentially corrosive.

X2.5 Sulfides

X2.5.1 The sulfide determination is recommended because of its field expediency. A positive sulfide reaction reveals a potential problem due to sulfate-reducing bacteria. The sodium azide-iodine qualitative test is used. In this determination, a solution of 3 % sodium azide in a 0.1 N iodine solution is introduced into a test tube containing a sample of the soil in question. Sulfides catalyze the reaction between sodium azide and iodine, with the resulting evolution of nitrogen. If strong bubbling or foaming results, sulfides are present, and the presence of sulfate-reducing bacteria is indicated. If very slight bubbling is noted, sulfides are probably present in small concentration, and the result is noted as a trace.

X2.6 Moisture Content

X2.6.1 Since prevailing moisture content is extremely important to all soil corrosion, every effort must be made to determine this condition. It is not proposed, however, to determine specific moisture content of a soil sample, because of the probability that content varies throughout the year, but to question local authorities who are able to observe the conditions many times during the year. (Although mentioned in



X2.2, this variability factor is being reiterated to emphasize the importance of notation.)

X2.7 Soil Description

X2.7.1 In each investigation, soil types should be described completely. The description should include color and physical characteristics, such as particle size, plasticity, friability, and uniformity. Observation and testing will reveal whether the soil is high in organic content; this should be noted. Experience has shown that in a given area, corrosivity may often be reflected in certain types and colors of soil. This information is valuable for future investigations or for determining the most likely soils to suspect. Soil uniformity is important because of the possible development of local corrosion cells due to the difference in potential between unlike soil types, both of which are in contact with the pipe. The same is true for uniformity of aeration. If one segment of soil contains more oxygen than a neighboring segment, a corrosion cell can develop from the difference in potential. This cell is known as a differential aeration cell.

X2.7.2 There are several basic types of soil that should be noted: sand, loam, silt, clay, muck. Unusual soils, such as peat or soils high in foreign material, should also be noted and described.

X2.8 Potential Stray Direct Current

X2.8.1 Any soil survey should include consideration of possible stray direct current with which the cast iron pipe installation might interfere. The widespread use of rectifiers and ground beds for cathodic protection of underground structures has resulted in a considerable threat from this source. Proximity of such cathodic protection systems should be noted.

Among other potential sources of stray direct current are electric railways, industrial equipment, including welding, and mine transportation equipment.

X2.9 Experience With Existing Installations

X2.9.1 The best information on corrosivity of soil with respect to cast iron pipe is the result of experience with these materials in the area in question. Every effort should be made to acquire such data by questioning local officials and, if possible, by actual observation of existing installations.

X2.10 Soil-Test Evaluation

X2.10.1 Using the soil-test procedures described herein, the following tests are considered in evaluating corrosivity of the soil: resistivity, pH, redox potential, sulfides, and moisture. For each of these tests, results are categorized according to their contribution to corrosivity. Points are assigned based on experience with gray and ductile cast iron pipe. When results of these five test observations are available, the assigned points are totaled. If the sum is equal to ten or more, the soil is corrosive to cast iron pipe and protection against exterior corrosion should be provided. This system is limited to soil corrosion and does not include consideration of stray direct current. Table X2.1 lists points assigned to the various test results.

X2.11 General

X2.11.1 These notes deal only with cast iron pipe, the soil environment in which they will serve, and methods of determining the need for polyethylene encasement. When it is determined that a soil environment is corrosive to cast iron the practice outlined in Appendix X3 should be used.

X3. POLYETHYLENE ENCASUREMENT FOR CAST IRON PIPE FOR WASTE WATER

X3.1 Scope

X3.1.1 This practice covers materials and installation procedures for polyethylene encasement to be applied to underground installations of cast iron pipe. It is also used for polyethylene encasement of fittings, and other appurtenances to cast iron pipe systems.

X3.1.2 *This standard does not purport to address all of the safety concerns, if any, associated with its use. It is the responsibility of the user of this standard to establish appropriate safety and health practices and determine the applicability of regulatory limitations prior to use.*

X3.2 Referenced Documents

X3.2.1 *ASTM Standard:*

D 1248 Specification for Polyethylene Plastics Molding and Extrusion Materials¹¹

X3.3 Terminology

X3.3.1 *Definitions:*

X3.3.1.1 *polyethylene encasement, n*—polyethylene material, in tube or sheet form, that is used to encase cast iron pipe.

X3.3.1.2 *securing overlap, n*—any one of various methods of holding polyethylene encasement in place at the point of overlap until backfilling operations are completed. This may be accomplished with adhesive tape, plastic string, or other suitable material.

X3.4 Requirements

X3.4.1 *Materials:*

X3.4.1.1 *Low-Density Polyethylene Film*—Low-density polyethylene film shall be manufactured of virgin polyethylene material conforming to the requirements of Table 2 in Specification D 1248.

(1) *Thickness*—Low-density Polyethylene film shall have a minimum nominal thickness of 0.008 in. (0.20 mm). The minus tolerance on thickness shall not exceed 10 % of the nominal thickness.

X3.4.1.2 *High-Density Cross-Laminated Polyethylene Film*—High-density cross-laminated polyethylene film shall be manufactured of virgin polyethylene material conforming to the requirements of Specification D 1248 as shown in Table X3.2.

(1) *Thickness*—High-density cross-laminated polyethylene film shall have a minimum nominal thickness of 0.004 in. (0.10

¹¹ Annual Book of ASTM Standards, Vol 08.01.

TABLE X3.1 Polyethylene Characteristics

Raw Material Used to Manufacture Polyethylene Encasement Material	
Type, class, grade, other characteristics in accordance with the latest revision of Specification D 1248:	
Type	I
Class	A—Natural color or C—Black
Grade	E1
Flow rate, g/10 min	0.4 max
Dielectric strength, volume resistivity	10 ¹⁵ ·cm ³ , min
Polyethylene Encasement Material	
Tensile strength	1200 psi (8 MPa), min
Elongation	300 %, min
Dielectric strength	800 V/mil (31.5 V/um) thickness, min

TABLE X3.2 Polyethylene Tube Sizes

Nominal Pipe Diameter, in.	Recommended Polyethylene Flat Tube Width, in. (cm) ^A
1½, 2, 3	14 (35)
4	16 (41)
6	20 (51)
8	24 (61)
10	27 (69)
12	30 (76)
14	34 (86)
15	37 (94)

^A For flat sheet polyethylene, see X3.5.2.3.

mm). The minus tolerance on thickness shall not exceed 10 % of the nominal thickness.

X3.4.2 Tube Size—The tube size for each pipe diameter shall be as listed in Table X2.2.

X3.5 Installation

X3.5.1 General:

X3.5.1.1 The polyethylene encasement shall prevent contact between the pipe and the surrounding backfill and bedding material but is not intended to be a completely airtight or watertight enclosure. All lumps of clay, mud, cinders, etc., that are on the pipe surface shall be removed prior to installation of the polyethylene encasement. During installation, care shall be exercised to prevent soil or embedment material from becoming entrapped between the pipe and the polyethylene.

X3.5.1.2 The polyethylene film shall be fitted to the contour of the pipe to effect a snug, but not tight, encasement with minimum space between the polyethylene and the pipe. Sufficient slack shall be provided in contouring to prevent stretching the polyethylene, bridging irregular surfaces such as hub-spigot interfaces, coupled joints, or fittings, and to prevent damage to the polyethylene due to backfilling operations. Overlaps and ends shall be secured by the use of adhesive tape, string, plastic tie straps, or any other material capable of holding the polyethylene encasement in place until backfilling operations are completed.

X3.5.1.3 For installations below the water table or in areas subject to tidal actions, or both, it is recommended that tube-form polyethylene be used with both ends sealed as thoroughly as possible with adhesive tape or plastic tie straps at the joint overlap. It is also recommended that circumferential wraps of tape or plastic tie straps be placed at 2-ft (0.6-m) intervals along the barrel of the pipe to help minimize the space between the polyethylene and the pipe.

X3.5.2 Pipe—This practice includes three different methods for the installation of polyethylene encasement. Method A and B are for use with polyethylene tubes, and Method C is for use with polyethylene sheets.

X3.5.2.1 Method A (see Fig. X3.1):

(1) Cut the polyethylene tube to a length approximately 2 ft (0.6 m) longer than the length of the pipe section. Slip the tube around the pipe, centering it to provide a 1-ft (0.3-m) overlap on each adjacent pipe section, and bunching it accordion fashion lengthwise until it clears the pipe ends.

(2) Lower the pipe into the trench and make up the pipe joint with the preceding section of pipe. A shallow bell hole must be made at joints to facilitate installation of the polyethylene tube.

(3) After assembling the pipe joint, make the overlap of the polyethylene tube. Pull the bunched polyethylene from the preceding length of pipe, slip it over the end of the new length of pipe, and secure in place. Then slip the end of the polyethylene from the new pipe section over the end of the first wrap until it overlaps the joint at the end of the preceding length of pipe. Secure the overlap in place. Take up the slack width at the top of the pipe as shown in Fig. X3.2, to make a snug, but not tight, fit along the barrel of the pipe, securing the fold at quarter points.

(4) Repair any rips, punctures, or other damage to the polyethylene with adhesive tape or with a short length of polyethylene tube cut open, wrapped around the pipe, and secured in place. Proceed with installations of the next section of pipe in the same manner.

X3.5.2.2 Cut the polyethylene tube to a length approximately 1 ft (0.3 m) shorter than the length of the pipe section. Slip the tube around the pipe, centering it to provide 6 in. (150 mm) of bare pipe at each end. Make the polyethylene snug, but not tight, as shown in Fig. X3.2; secure ends as described in X3.5.2.1.

X3.5.2.3 Before making up a joint, slip a 3-ft (0.9-m) length of polyethylene tube over the end of the preceding pipe section, bunching it accordion fashion lengthwise. After completing the joint, pull the 3-ft length of polyethylene previously installed on each adjacent section of pipe by at least 1 ft (0.3 m); make snug and secure each end as described in X3.5.2.1.

X3.5.2.4 Repair any rips, punctures, or other damage to the polyethylene as described in X3.5.2.1. Proceed with installation of the next section of pipe in the same manner.

X3.5.3 Flat sheet polyethylene shall have a minimum width twice the flat tube width shown in Table X3.3.

X3.5.3.1 Cut the polyethylene sheet to a length approximately 2 ft (0.6 m) longer than the length of pipe section. Center the cut length to provide a 1-ft (0.3-m) overlap on each adjacent pipe section, bunching it until it clears the pipe ends. Wrap the polyethylene around the pipe so that it overlaps circumferentially over the top quadrant of the pipe. Secure the cut edge of polyethylene sheet at approximately 3-ft (0.9-m) intervals along the pipe length.

X3.5.3.2 Lower the wrapped pipe into the trench and make up the pipe joint with the preceding section of pipe. A shallow hub hole must be made at joints to facilitate installation of the polyethylene. After completing the joint, make the overlap as

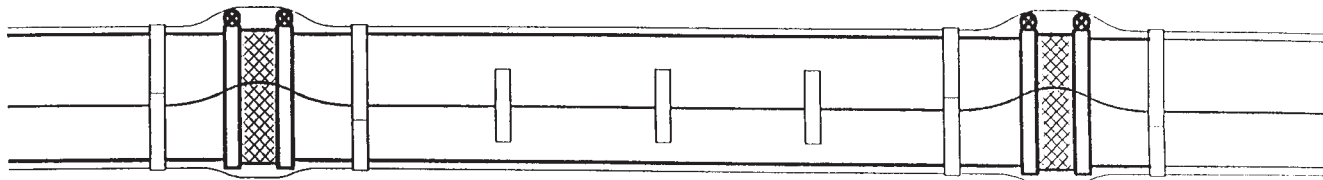

FIG. X3.1 Method A Hubless Pipe

described in X3.5.2.1.

X3.5.3.3 Repair any rips, punctures, or other damage to the polyethylene as described in X3.5.2.1. Proceed with installation of the next section of pipe in the same manner.

X3.5.4 *Pipe-Shaped Appurtenances*—Bends, reducers, off-sets, and other pipe-shaped appurtenances shall be covered with polyethylene in the same manner as the pipe.

X3.5.5 *Odd-Shaped Appurtenances*—Wrap tees, crosses, and other odd-shaped pieces that cannot practically be wrapped in a tube, with a flat sheet or split length of polyethylene tube. Pass the sheet under the appurtenance and bring up around the body. Make seams by bringing the edges together, folding over twice, and taping down (see Fig. X3.3). Handle slack width and overlaps at joints as described in X3.5.2.1. Tape polyethylene securely in place.

X3.5.6 *Repairs*—Repair any cuts, tears, punctures, or damage to polyethylene with adhesive tape or with a short length of polyethylene tube cut open, wrapped around the pipe covering the damaged area, and secured in place.

X3.5.7 *Junctions Between Wrapped and Unwrapped Pipe*—Where polyethylene-wrapped pipe joins a pipe that is not wrapped, extend the polyethylene tube to cover the unwrapped pipe a distance of at least 3 ft (0.9 m). Secure the end with circumferential turns of tape.

X3.5.8 *Backfill for Polyethylene-Wrapped Pipe*—Backfill material shall be the same as specified for pipe without polyethylene wrapping. Take special care to prevent damage to the polyethylene wrapping when placing backfill. Backfill material shall be free of cinders, refuse, boulders, rocks, stones, or other material that could damage polyethylene.

ASTM International takes no position respecting the validity of any patent rights asserted in connection with any item mentioned in this standard. Users of this standard are expressly advised that determination of the validity of any such patent rights, and the risk of infringement of such rights, are entirely their own responsibility.

This standard is subject to revision at any time by the responsible technical committee and must be reviewed every five years and if not revised, either reapproved or withdrawn. Your comments are invited either for revision of this standard or for additional standards and should be addressed to ASTM International Headquarters. Your comments will receive careful consideration at a meeting of the responsible technical committee, which you may attend. If you feel that your comments have not received a fair hearing you should make your views known to the ASTM Committee on Standards, at the address shown below.

This standard is copyrighted by ASTM International, 100 Barr Harbor Drive, PO Box C700, West Conshohocken, PA 19428-2959, United States. Individual reprints (single or multiple copies) of this standard may be obtained by contacting ASTM at the above address or at 610-832-9585 (phone), 610-832-9555 (fax), or service@astm.org (e-mail); or through the ASTM website (www.astm.org).

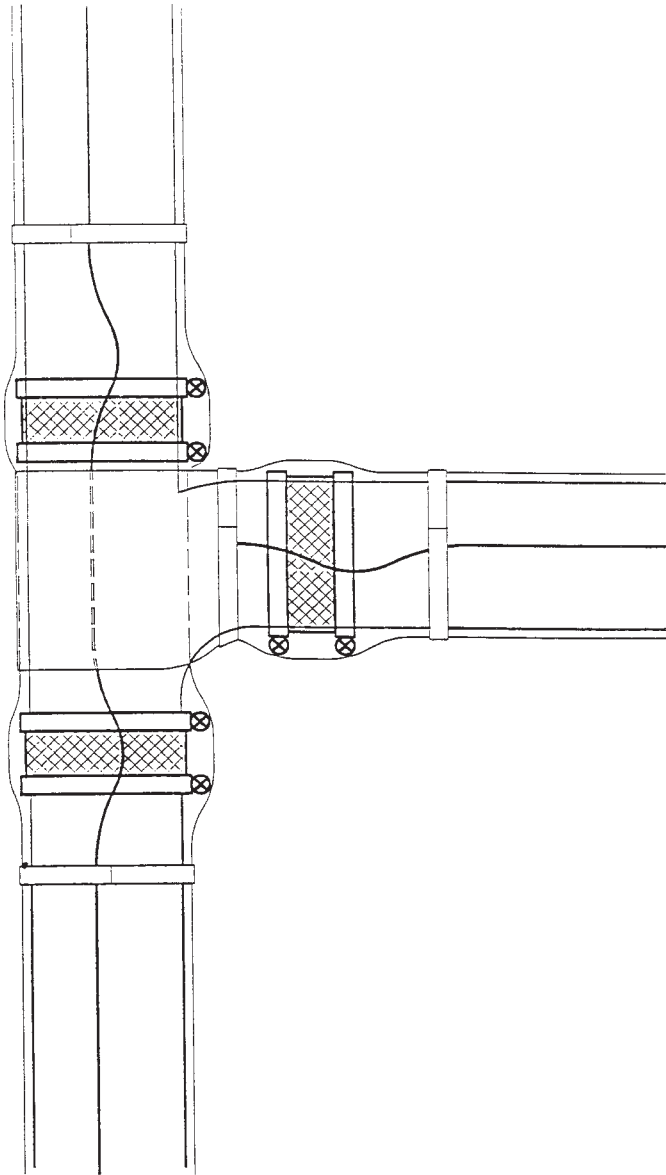

FIG. X3.3 Installation on Odd-Shaped Appurtenances Hubless Pipe

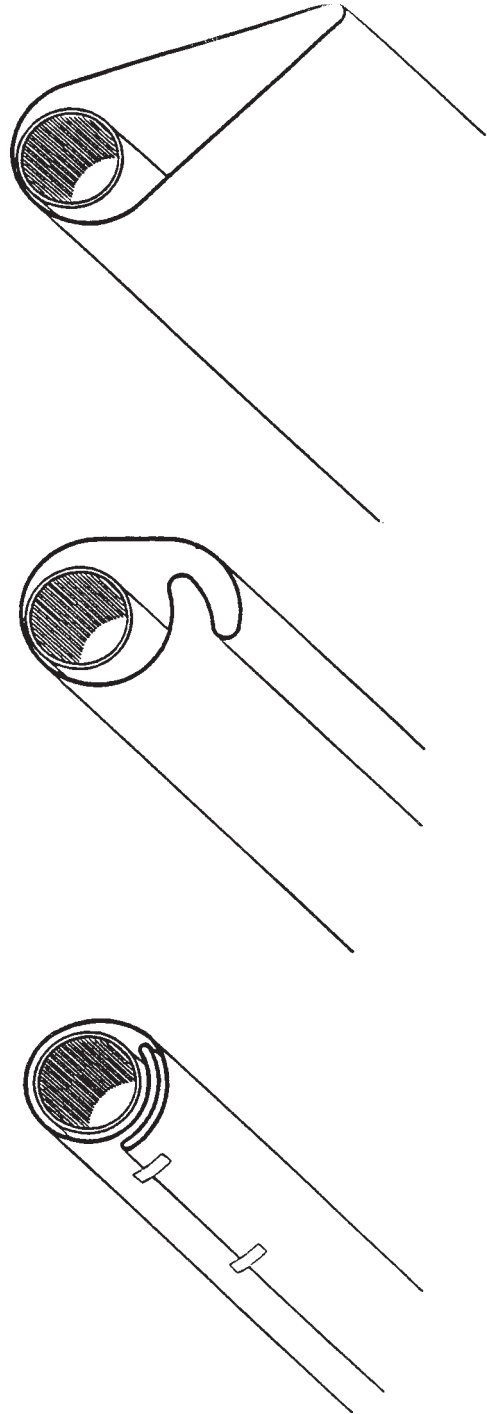
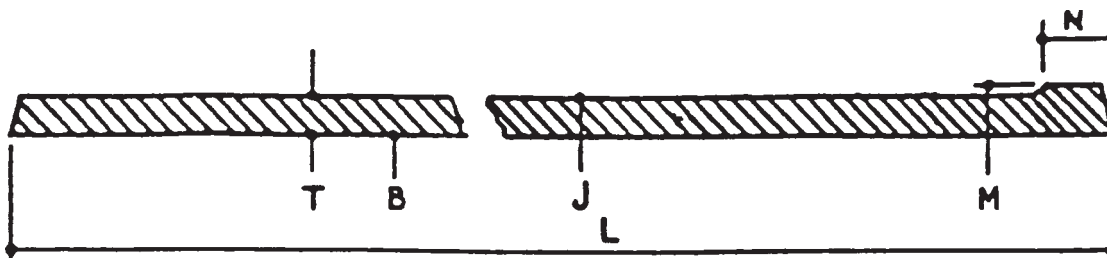

FIG. X3.2 Method A Slack Reduction Procedure



*Pipe shall be with or without a spigot bead.

Size	Barrel		Spigot		Barrel Thickness, T		Gasket Positioning Lug ^A	Laying Length, L ^B
	Inside Diameter	Outside Diameter	Outside Diameter	Bead Width ^A	Nominal	Minimum	W	10 ft ± 0.50 in. (3.0480 m ± 13 mm)
	B	J	M	N, ± 0.13 (3.3)				
1½	1.50 ± 0.09 (38.1 ± 2.29)	1.90 ± 0.06 (48.26 ± 1.52)	1.96 ± 0.06 (49.78 ± 1.52)	0.25 (6.35)	0.16	0.13 (3.3)	1.13 (28.7)	120 (3048)
2	1.96 ± 0.09 (49.8 ± 2.29)	2.35 ± 0.09 (59.69 ± 2.29)	2.41 ± 0.09 (61.21 ± 2.29)	0.25 (6.35)	0.16	0.13 (3.3)	1.13 (28.7)	120 (3048)
3	2.96 ± 0.09 (75.2 ± 2.29)	3.35 ± 0.09 (85.09 ± 2.29)	3.41 ± 0.09 (86.61 ± 2.29)	0.25 (6.35)	0.16	0.13 (3.3)	1.13 (28.7)	120 (3048)
4	3.94 ± 0.09 (100.08 ± 2.29)	4.38 ± 0.09 (111.25 ± 2.29)	4.44 ± 0.09 (112.78 ± 2.29)	0.31 (7.87)	0.19	0.15 (3.81)	1.13 (28.7)	120 (3048)
5	4.94 ± 0.09 (125.48 ± 2.29)	5.30 ± 0.09 (134.62 ± 2.29)	5.36 ± 0.09 (136.14 ± 2.29)	0.31 (7.87)	0.19	0.15 (3.81)	1.50 (38.1)	120 (3048)
6	5.94 ± 0.09 (150.88 ± 2.29)	6.30 ± 0.09 (160.02 ± 2.29)	6.36 ± 0.09 (161.54 ± 2.29)	0.31 (7.87)	0.19	0.15 (3.81)	1.50 (38.1)	120 (3048)
8	7.94 ± 0.13 (201.68 ± 3.3)	8.38 ± 0.13 (212.85 ± 3.3)	8.44 ± 0.09 (214.38 ± 2.29)	0.31 (7.87)	0.23	0.17 (4.32)	2.00 (50.8)	120 (3048)
10	10.00 ± 0.13 (254 ± 3.3)	10.56 ± 0.09 (268.22 ± 2.29)	10.62 ± 0.09 (269.75 ± 2.29)	0.31 (7.87)	0.28	0.22 (5.59)	2.00 (50.8)	120 (3048)
12	11.94 ± 0.9 (303.28 ± 2.29)	12.50 ± .09 (317.5 ± 2.29)	12.62 ± .09 (320.55 ± 2.29)	0.31 (7.87)	0.28	.22 (5.59)	2.75 (69.85)	120 (3048)
15	15.11 ± .09 (383.79 ± 2.29)	15.83 ± .09 (402.08 ± 2.29)	16.12 ± .09 (409.45 ± 2.29)	0.31 (7.87)	0.36	.30 (7.62)	2.75 (69.85)	120 (3048)

^A See Fig. 2 for details of the spigot and gasket positioning lug.

^B Laying lengths as listed in Fig. 1 shall be for pipe only, and such pipe shall be 10 ft (3m) long. Laying length for fittings are listed in the applicable tables.

FIG. 1 Dimensions and Tolerances in Inches (Millimetres) of Spigots and Barrels for Hubless Pipe and Fittings

TABLE X3.3 High-Density Cross-Laminated Polyethylene Characteristics

Raw Material Used to Manufacture Polyethylene Encasement Material	
Type, class, grade, other characteristics in accordance with the latest revision of Specification D 1248:	
Type	111
Class	A—Natural color, B—Colors, or C—Black
Grade	P33
Flow rate, g/10 min	0.4 to 0.5 g/10 min
Dielectric strength, volume resistivity	10 ¹⁵ ohm-cm-min
High-Density Cross-Laminated Polyethylene Encasement Material	
Tensile strength	5000 psi (34.6 MPa), min
Elongation	100 %, min
Dielectric strength	800 V/mil (31.5 V/um) thickness, min

ASTM A 888 – 98^{e1}

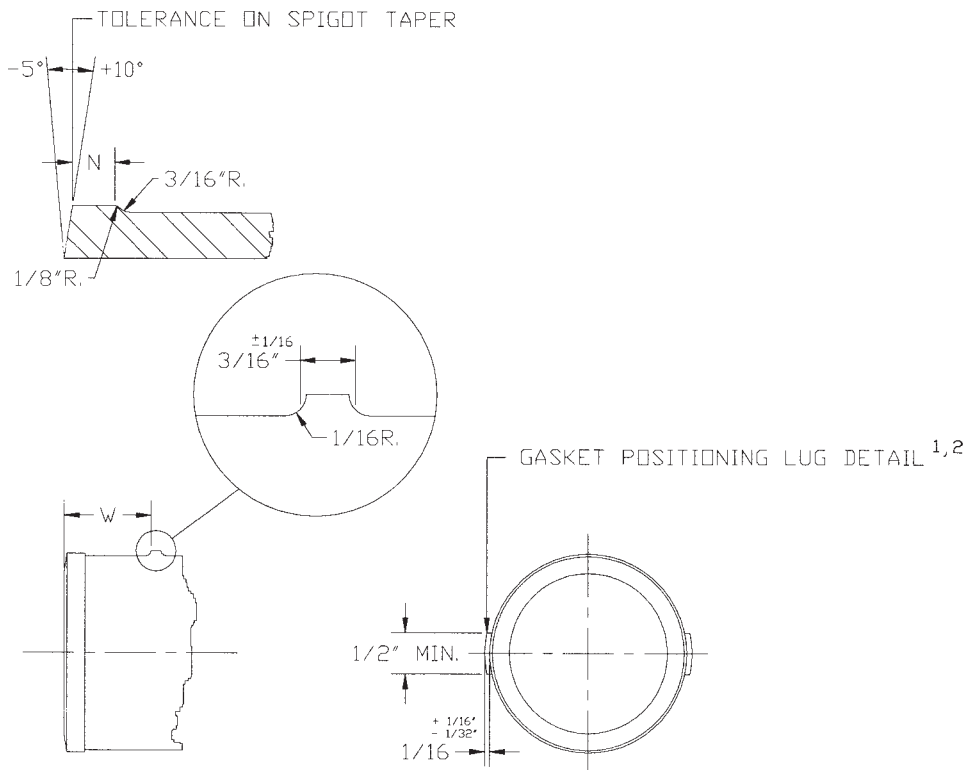

NOTE 1—Pipe shall be cast with or without the gasket positioning lugs. These lugs, as illustrated above, shall be cast as illustrated or be continuous around the entire circumference.

NOTE 2—Gasket positioning lugs shall be cast on all fittings except as otherwise noted. These lugs, as illustrated above, shall be cast as illustrated or be continuous around the entire circumference.

Size, in.	Spigot Detail, N in. (mm) ±0.13 (3.3)	Gasket Lug Location, W in. (mm) ±0.13 (3.3)
1½	0.25 (6)	1.13 (29)
2	0.25 (6)	1.13 (29)
3	0.25 (6)	1.13 (29)
4	0.25 (6)	1.13 (29)
5	0.31 (8)	1.50 (38)
6	0.31 (8)	1.50 (38)
8	0.31 (8)	2.00 (51)
10	0.31 (8)	2.00 (51)
12	0.31 (8)	2.75 (70)
15	0.31 (8)	2.75 (70)

FIG. 2 Details of Spigot Bead and Gasket Positioning Lug

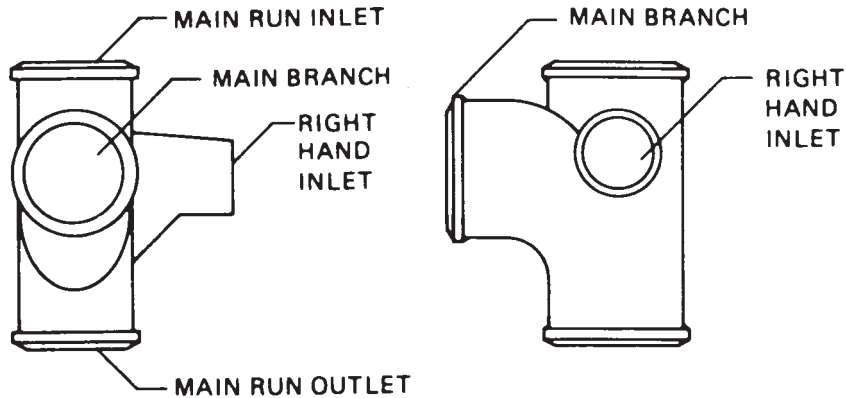
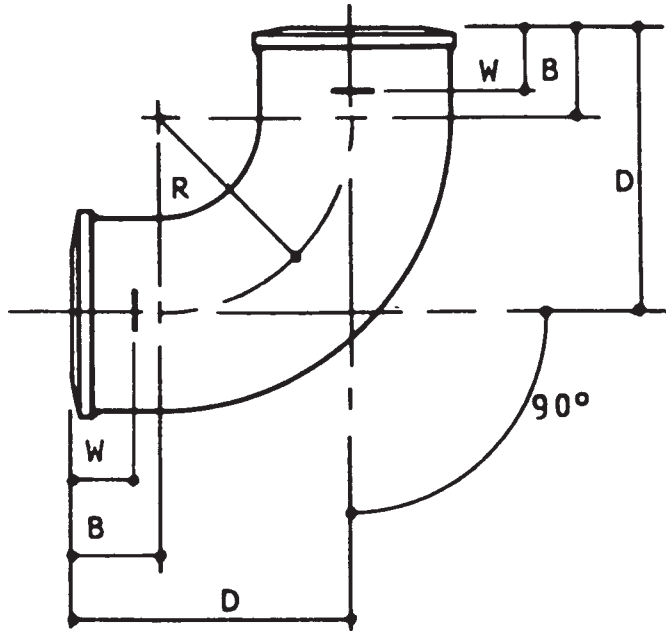

FIG. 3 Specifying Hand of Fittings with Side Inlets or Outlets

ASTM A 888 – 98^{e1}



ASA Code Group 022		Size, in.	Dimensions, in. (mm) ^A			
Item No.	√		B	$D^{B \pm 1/8}$ (3.2)	R	W
0188	7	1½	1½ (38)	4¼ (108)	2¾ (70)	1⅞ (29)
0190	3	2	1½ (38)	4½ (114)	3 (76)	1⅞ (29)
0192	9	3	1½ (38)	5 (127)	3½ (89)	1⅞ (29)
0194	5	4	1½ (38)	5½ (140)	4 (102)	1⅞ (29)
0196	0	5	2 (51)	6½ (165)	4½ (114)	1½ (38)
0198	6	6	2 (51)	7 (178)	5 (127)	1½ (38)
0200	0	8	2½ (64)	8½ (216)	6 (152)	2 (51)

^A For details of barrel, spigot, and gasket positioning lug, see Fig. 1 and Fig. 2.

^B Dimension D is laying length.

FIG. 4 ¼ Bend (corresponds to Table 5 of CISPI Specification 301)

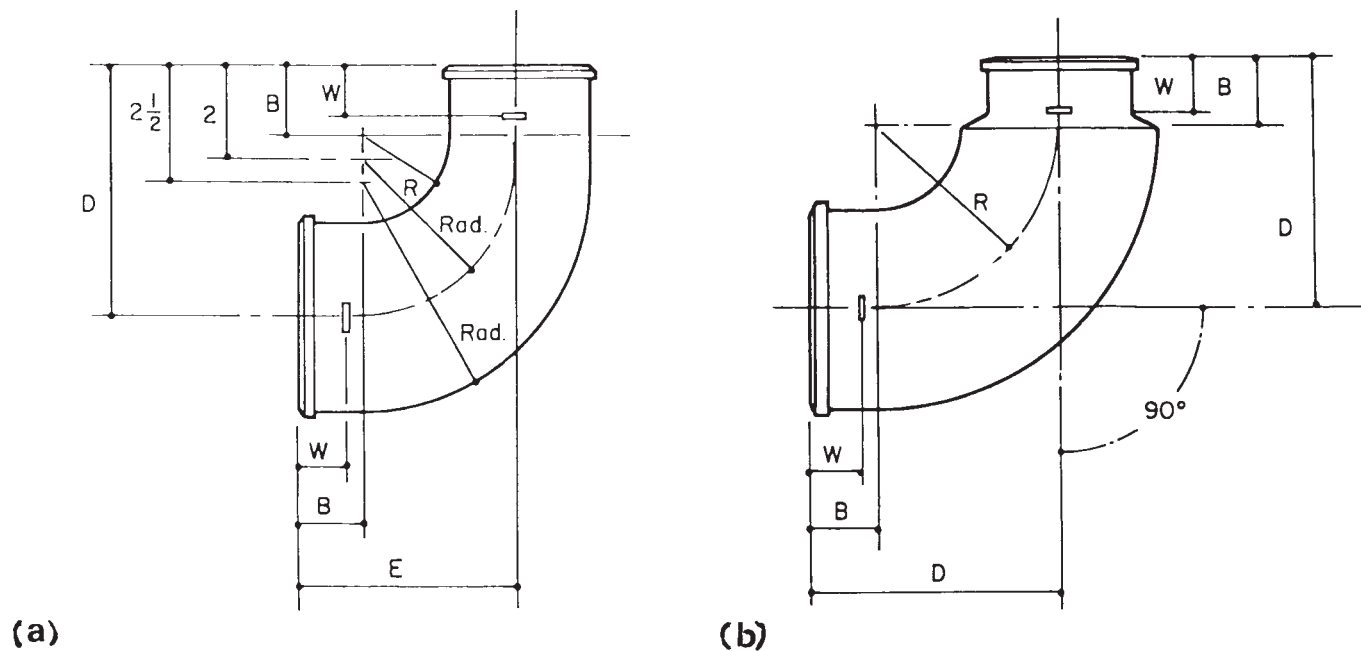

ASA Code Group 022		Item No.	✓	Sizes, in.	Dimensions, in. (mm) ^A				
					B	R	D ^B ± 1/8 (3.2)	E ^B ± 1/8 (3.2)	W
Fig. (a)	0218	2		4 by 3	1 1/2 (38)	3 1/2 (89)	5 1/2 (140)	5 (127)	1 1/8 (29)
Fig. (b)	0218	2		4 by 3	1 1/2 (38)	4 (102)	5 1/2 (140)	...	1 1/8 (29)

^A For details of barrel, spigot, and gasket positioning lug, see Fig. 1 and Fig. 2.

^B Dimensions D and E are laying lengths.

FIG. 5 Reducing 1/4 Bend (corresponds to Tables 6 and 7 of CISPI Specification 301)

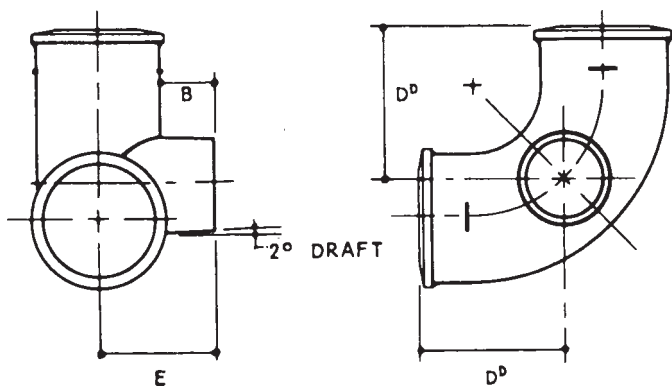

NOTE 1—For details of 1/4 bend, see Fig. 4.

NOTE 2—Inclusion of spigot bead and positioning lug optional with manufacturer based on casting method used.

ASA Code Group 022		Item No.	✓	Sizes, in.	Dimensions, in. (mm) ^A		
					B	E ^B ± 1/8 (3.2)	D ^B
0236	4	3 by 2		1 1/2 (38)	3 1/4 (83)	4 (102)	
0238	0	4 by 2		1 1/2 (38)	3 3/4 (95)	4 5/16 (110)	

^A For details of barrel, spigot, and gasket positioning lug, see Fig. 1 and Fig. 2.

^B Dimension E is laying length.

FIG. 6 1/4 Bend With Side Opening (corresponds to Table 8 of CISPI Specification 301)

ASTM A 888 – 98^{e1}

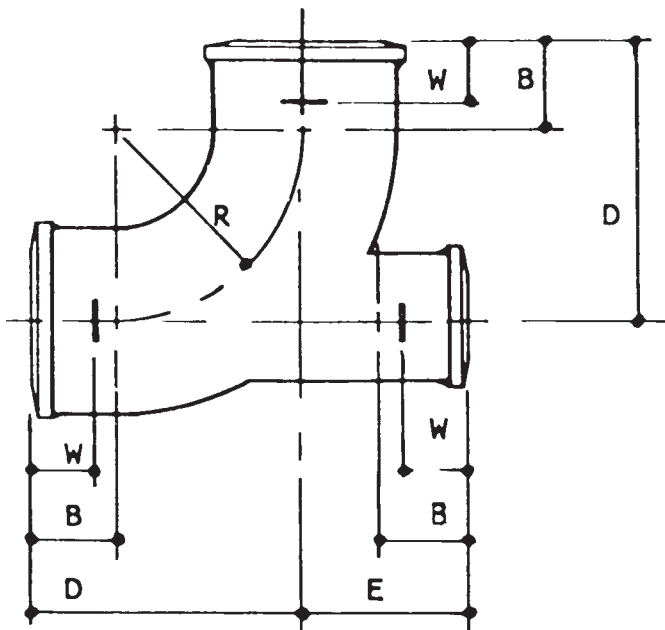

ASA Code Group 022		Size, in.	Dimensions, in. (mm) ^A				
Item No.	√		B	D ^B ± 1/8 (3.2)	E ^B ± 1/8 (3.2)	R	W
0280	2	3 by 2	1 1/2 (38)	5 (127)	2 7/8 (73)	3 1/2 (89)	1 1/8 (29)
0282	8	4 by 2	1 1/2 (38)	5 1/2 (140)	3 1/4 (83)	4 (102)	1 1/8 (29)

^A For details of barrel, spigot, and gasket positioning lug, see Fig. 1 and Fig. 2.

^B Dimensions D and E are laying lengths.

FIG. 7 1/4 Bend With Heel Opening (corresponds to Table 9 of CISPI Specification 301)

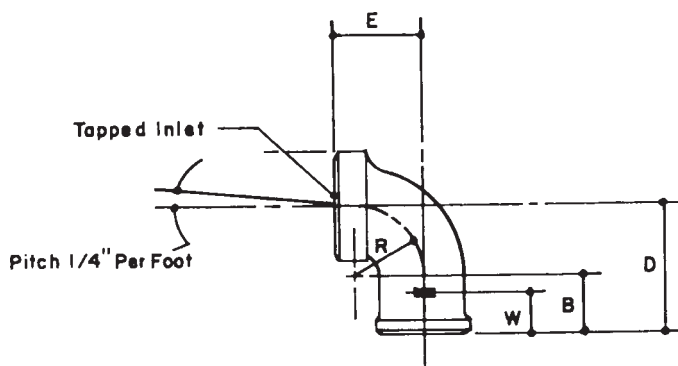

ASA Code Group 022		Size, in.	Dimensions, in. (mm) ^A					
Item No.	√		B	E	D ^B ± 1/8 (3.2)	R	IPS Tapping ^C	W
0324	8	1 1/2 by 1 1/4	1 1/2 (38)	2 (51)	3 (76)	1 3/4 (44)	1 1/4 (32)	1 1/8 (29)
0326	3	1 1/2 by 1 1/2	1 1/2 (38)	2 (51)	3 (76)	1 3/4 (44)	1 1/2 (38)	1 1/8 (29)
0328	9	2 by 1 1/4	1 1/2 (38)	2 1/4 (57)	3 1/4 (83)	1 3/4 (44)	1 1/4 (32)	1 1/8 (29)
0330	5	2 by 1 1/2	1 1/2 (38)	2 1/4 (57)	3 1/4 (83)	1 3/4 (44)	1 1/2 (38)	1 1/8 (29)

^A For details of barrel, spigot, and gasket positioning lug, see Fig. 1 and Fig. 2.

^B Dimension D is laying length.

^C For details of tapping bosses, see Fig. 62.

FIG. 8 Tapped 1/4 Bend (corresponds to Table 11 of CISPI Specification 301)

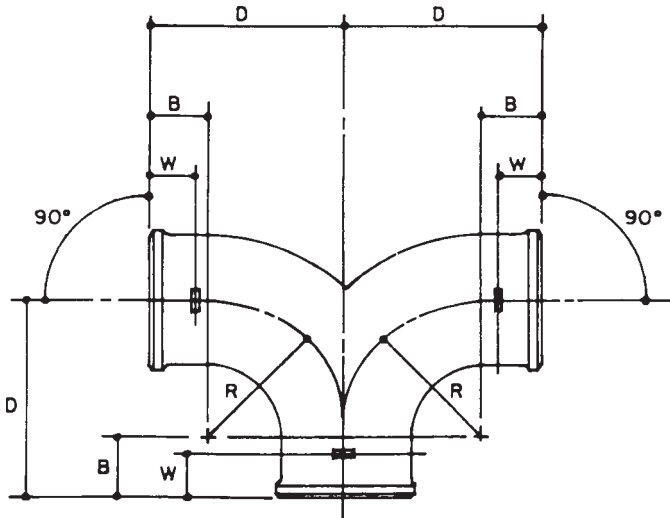

ASA Code		Dimensions, in. (mm) ^A				
Group 022		Size, in.				
Item No.	√		$D^B \pm \frac{1}{8}$ (3.2)	R	B	W
0402	2	2	4½ (114)	3 (76)	1½ (38)	1⅝ (29)
0404	8	3	5 (127)	3½ (89)	1½ (38)	1⅝ (29)
0406	3	4	5½ (140)	4 (102)	1½ (38)	1⅝ (29)

^A For details of barrel, spigot, and gasket positioning lug, see Fig. 1 and Fig. 2.

^B Dimension D is laying length.

FIG. 9 Double ¼ Bend (corresponds to Table 13 of CISPI Specification 301)

ASTM A 888 – 98^{e1}

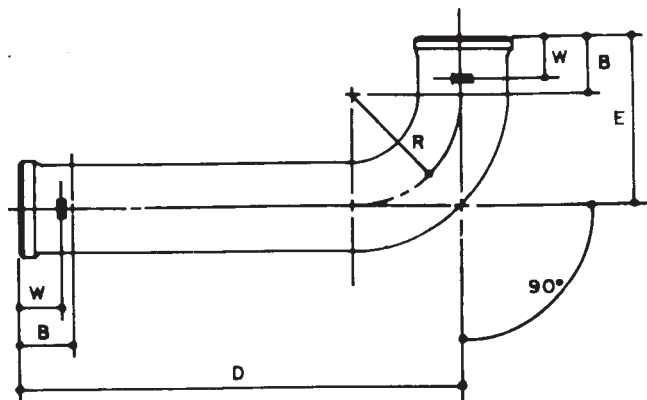

ASA Code Group 022		Size, in.	Dimensions, in. (mm) ^A				
Item No.	√		B	E ^{B±1/8} (3.2)	D ^{B±1/8} (3.2)	R	W
0424	6	2 by 12	1½ (38)	4½ (114)	12 (305)	3 (76)	1⅝ (29)
0423	8	2 by 16	1½ (38)	4½ (114)	16 (406)	3 (76)	1⅝ (29)
0425	3	2 by 18	1½ (38)	4½ (114)	18 (457)	3 (76)	1⅝ (29)
0426	1	3 by 12	1½ (38)	5 (127)	12 (305)	3½ (89)	1⅝ (29)
0427	9	3 by 18	1½ (38)	5 (127)	18 (457)	3½ (89)	1⅝ (29)
0428	7	4 by 12	1½ (38)	5½ (140)	12 (305)	4 (102)	1⅝ (29)
0431	1	4 by 18	1½ (38)	5½ (140)	18 (457)	4 (102)	1⅝ (29)

^A For details of barrel, spigot, and gasket positioning lug, see Fig. 1 and Fig. 2.

^B Dimensions D and E are laying lengths.

FIG. 10 Long ¼ Bend (corresponds to Table 14 of CISPI Specification 301)

ASTM A 888 – 98^{e1}

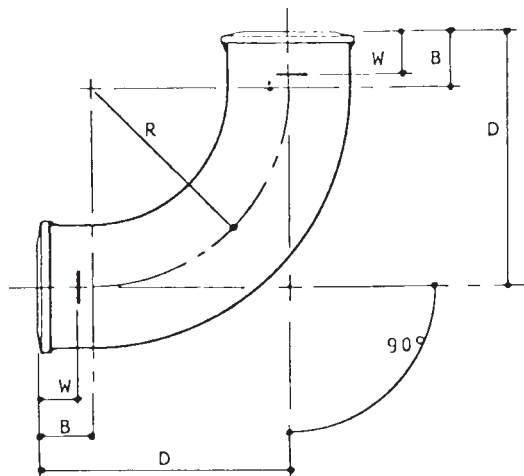

ASA Code Group 022		Size, in.	Dimensions, in. (mm) ^A			
Item No.	✓		B	D ^{B±1/8} (3.2)	R	W
0462	6	2	1½ (38)	6½ (165)	5 (127)	1⅞ (29)
0464	2	3	1½ (38)	7 (178)	5½ (140)	1⅞ (29)
0468	3	4	1½ (38)	7½ (191)	6 (152)	1⅞ (29)
0470	9	5	2 (51)	8½ (216)	6½ (165)	1½ (38)
0472	5	6	2 (51)	9 (229)	7 (178)	1½ (38)
0474	1	8	2½ (64)	10½ (267)	8 (203)	2 (51)
0475	8	10	3 (76)	12 (305)	9 (229)	2 (51)
0476	8	12	3 ¼ (83)	13 ¼ (337)	10 (254)	2 ¾ (70)
0477	8	15	3 ¼ (83)	14 ¾ (375)	11 ½ (292)	2 ¾ (70)

^A For details of barrel, spigot, and gasket positioning lug, see Fig. 1 and Fig. 2.

^B Dimension D is laying length.

FIG. 11 Short Sweep (corresponds to Table 15 of CISPI Specification 301)

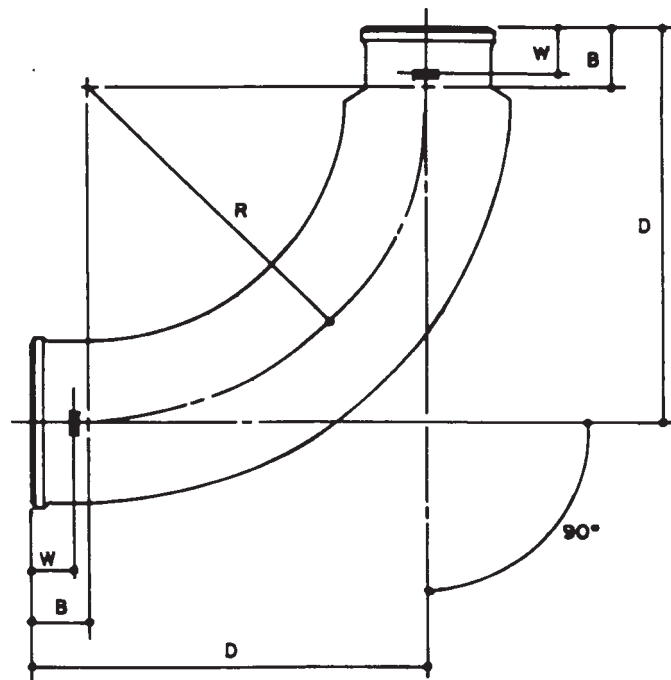
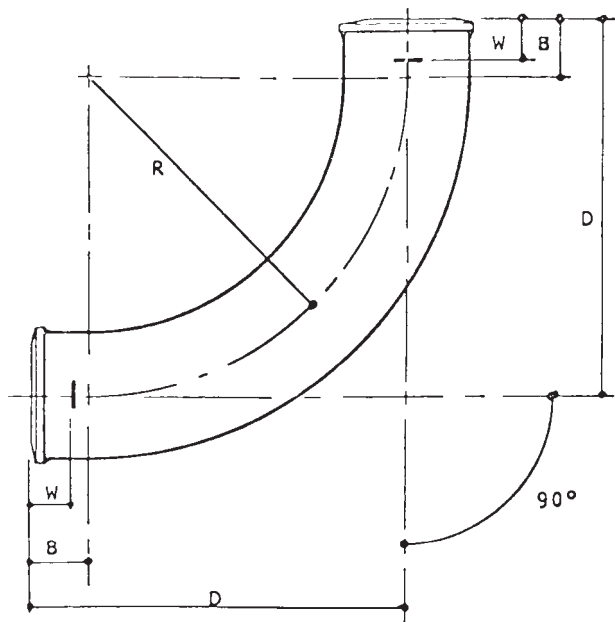

ASA Code Group 022		Dimensions, in. (mm) ^A				
Item No.	✓	Size, in.	B	D ^B ± 1/8 (3.2)	R	W
0492	3	1½	1½ (38)	9¼ (235)	7¾ (197)	1⅝ (29)
0494	9	2	1½ (38)	9½ (241)	8 (203)	1⅝ (29)
0496	4	3	1½ (38)	10 (254)	8½ (216)	1⅝ (29)
0498	0	4	1½ (38)	10½ (267)	9 (229)	1⅝ (29)
0500	3	5	2 (51)	11½ (292)	9½ (241)	1½ (38)
0502	9	6	2 (51)	12 (305)	10 (254)	1½ (38)

ASA Code Group 022		Dimensions, in. (mm) ^A				
Item No.	✓	Size, in.	B	D ^B ± 1/8 (3.2)	R	W
0516	9	3 by 2	1½ (38)	10 (254)	8½ (216)	1⅝ (29)
0518	5	4 by 3	1½ (38)	10½ (267)	9 (229)	1⅝ (29)

^A For details of barrel, spigot, and gasket positioning lug, see Fig. 1 and Fig. 2.
^B Dimension D is laying length.

^A For details of barrel, spigot, and gasket positioning lug, see Fig. 1 and Fig. 2.
^B Dimension D is laying length.

FIG. 12 Long Sweep (corresponds to Table 17 of CISPI Specification 301)

FIG. 13 Reducing Long Sweep (corresponds to Table 18 of CISPI Specification 301)

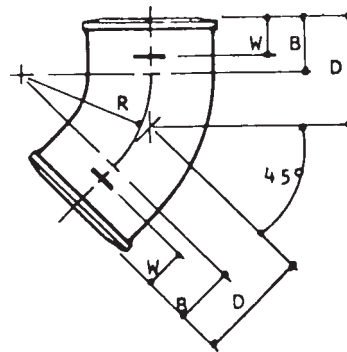
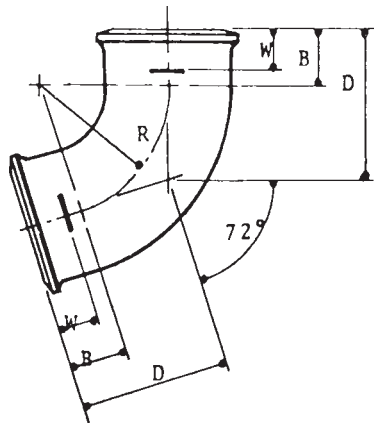

ASA Code Group 022	Size, in.	Dimensions, in. (mm) ^A				
Item No.	√	B	D ^B ± 1/8 (3.2)	R	W	
0536	7 2	1 1/2 (38)	3 11/16 (94)	3 (76)	1 1/8 (29)	
0538	3 3	1 1/2 (38)	4 1/16 (103)	3 1/2 (89)	1 1/8 (29)	
0540	9 4	1 1/2 (38)	4 7/16 (113)	4 (102)	1 1/8 (29)	

^A For details of barrel, spigot, and gasket positioning lug, see Fig. 1 and Fig. 2.

^B Dimension D is laying length.

FIG. 14 1/8 Bend (corresponds to Table 19 of CISPI Specification 301)

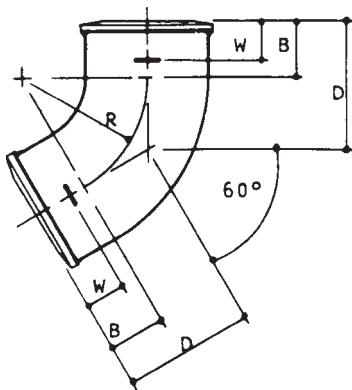

ASA Code Group 022	Size, in.	Dimensions, in. (mm) ^A				
Item No.	√	B	D ^B ± 1/8 (3.2)	R	W	
0570	6 2	1 1/2 (38)	3 1/4 (83)	3 (76)	1 1/8 (29)	
0572	2 3	1 1/2 (38)	3 1/2 (89)	3 1/2 (89)	1 1/8 (29)	
0574	8 4	1 1/2 (38)	3 13/16 (97)	4 (102)	1 1/8 (29)	

^A For details of barrel, spigot, and gasket positioning lug, see Fig. 1 and Fig. 2.

^B Dimension D is laying length.

FIG. 15 1/8 Bend (corresponds to Table 20 of CISPI Specification 301)

ASA Code Group 022	Size, in.	Dimensions, in. (mm) ^A				
Item No.	√	B	D ^B ± 1/8 (3.2)	R	W	
0604	3 1 1/2	1 1/2 (38)	2 5/8 (67)	2 3/4 (70)	1 1/8 (29)	
0606	8 2	1 1/2 (38)	2 3/4 (70)	3 (76)	1 1/8 (29)	
0608	4 3	1 1/2 (38)	3 (76)	3 1/2 (89)	1 1/8 (29)	
0610	0 4	1 1/2 (38)	3 1/8 (79)	4 (102)	1 1/8 (29)	
0612	6 5	2 (51)	3 7/8 (98)	4 1/2 (114)	1 1/2 (38)	
0614	2 6	2 (51)	4 1/16 (103)	5 (127)	1 1/2 (38)	
0616	7 8	2 1/2 (64)	5 (127)	6 (152)	2 (51)	
0617	5 10	3 (76)	5 15/16 (151)	7 (178)	2 (51)	
0618	5 12	3 1/4 (83)	6 9/16 (167)	8 (203)	2 3/4 (70)	
0619	5 15	3 1/4 (83)	7 3/16 (183)	9 1/2 (241)	2 3/4 (70)	

^A For details of barrel, spigot, and gasket positioning lug, see Fig. 1 and Fig. 2.

^B Dimension D is laying length.

FIG. 16 1/8 Bend (corresponds to Table 21 of CISPI Specification 301)

ASTM A 888 – 98^{e1}

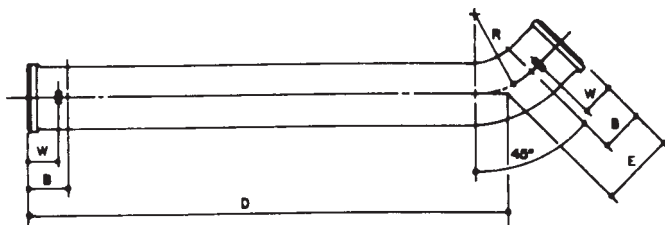

ASA Code Group 022		Size, in.	Dimensions, in. (mm) ^A				
Item No.	✓		B	E ^{B±1/8} (3.2)	D ^{B±1/8} (3.2)	R	W
0638	1	2 by 12	1½ (38)	2¾ (70)	12 (305)	3 (76)	1⅞ (29)
0641	5	2 by 16	1½ (38)	2¾ (70)	16 (406)	3 (76)	1⅞ (29)
0643	1	2 by 18	1½ (38)	2¾ (70)	18 (457)	3 (76)	1⅞ (29)
0640	7	3 by 12	1½ (38)	3 (76)	12 (305)	3½ (89)	1⅞ (29)
0644	9	3 by 18	1½ (38)	3 (76)	18 (457)	3½ (89)	1⅞ (29)
0642	3	4 by 12	1½ (38)	3⅞ (79)	12 (305)	4 (102)	1⅞ (29)

^A For details of barrel, spigot, and gasket positioning lug, see Fig. 1 and Fig. 2.

^B Dimensions D and E are laying lengths.

FIG. 17 Long 1/8 Bend (corresponds to Table 22 of CISPI Specification 301)

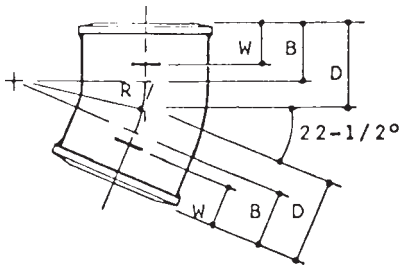

ASA Code Group 022		Size, in.	Dimensions, in. (mm) ^A			
Item No.	✓		B	D ^{B±1/8} (3.2)	R	W
0676	1	1½	1½ (38)	2⅞ (54)	2¾ (70)	1⅞ (29)
0678	7	2	1½ (38)	2⅞ (54)	3 (76)	1⅞ (29)
0680	3	3	1½ (38)	2¼ (57)	3½ (89)	1⅞ (29)
0682	9	4	1½ (38)	2⅝ (59)	4 (102)	1⅞ (29)
0684	5	5	2 (51)	2⅞ (73)	4½ (114)	1½ (38)
0686	0	6	2 (51)	3 (76)	5 (127)	1½ (38)
0688	6	8	2½ (64)	3¾ (95)	6 (152)	2 (51)

^A For details of barrel, spigot, and gasket positioning lug, see Fig. 1 and Fig. 2.

^B Dimension D is laying length.

FIG. 18 1/16 Bend (corresponds to Table 23 of CISPI Specification 301)

ASTM A 888 – 98^{e1}

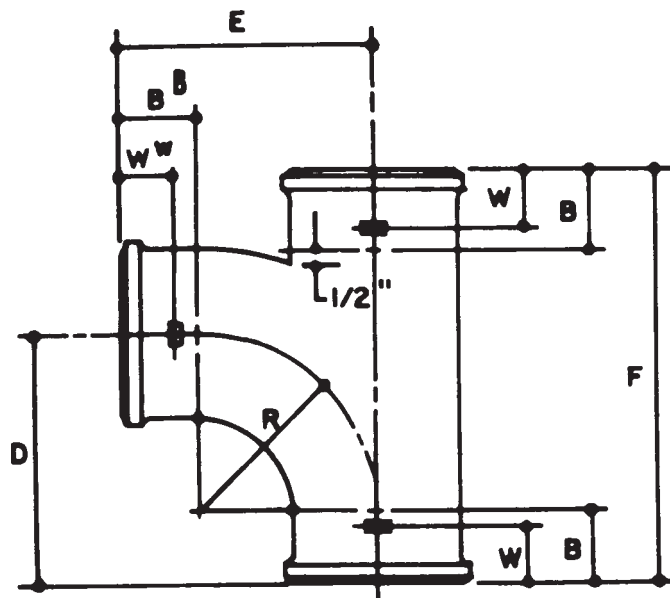

ASA Code Group 022		Size, in.	Dimensions, in. (mm) ^A							
Item No.	√		B	E ^B ± 1/8 (3.2)	F ^B ± 1/8 (3.2)	D	R	W	W ^W	B ^B
0806	4	1 1/2	1 1/2 (38)	4 1/4 (108)	6 1/2 (165)	4 1/4 (108)	2 3/4 (70)	1 1/8 (29)	1 1/8 (29)	1 1/2 (38)
0808	0	2 by 1 1/2	1 1/2 (38)	4 1/2 (114)	6 5/8 (168)	4 1/4 (108)	2 3/4 (70)	1 1/8 (29)	1 1/8 (29)	1 1/2 (38)
0810	6	2	1 1/2 (38)	4 1/2 (114)	6 7/8 (175)	4 1/2 (114)	3 (76)	1 1/8 (29)	1 1/8 (29)	1 1/2 (38)
0812	2	3 by 1 1/2	1 1/2 (38)	5 (127)	6 1/2 (165)	4 1/4 (108)	2 3/4 (70)	1 1/8 (29)	1 1/8 (29)	1 1/2 (38)
0814	8	3 by 2	1 1/2 (38)	5 (127)	6 7/8 (175)	4 1/2 (114)	3 (76)	1 1/8 (29)	1 1/8 (29)	1 1/2 (38)
0816	3	3	1 1/2 (38)	5 (127)	8 (203)	5 (127)	3 1/2 (89)	1 1/8 (29)	1 1/8 (29)	1 1/2 (38)
0818	9	4 by 2	1 1/2 (38)	5 1/2 (140)	6 7/8 (175)	4 1/2 (114)	3 (76)	1 1/8 (29)	1 1/8 (29)	1 1/2 (38)
0820	5	4 by 3	1 1/2 (38)	5 1/2 (140)	8 (203)	5 (127)	3 1/2 (89)	1 1/8 (29)	1 1/8 (29)	1 1/2 (38)
0822	1	4	1 1/2 (38)	5 1/2 (140)	9 1/8 (232)	5 1/2 (140)	4 (102)	1 1/8 (29)	1 1/8 (29)	1 1/2 (38)
0824	7	5 by 2	2 (51)	6 1/2 (165)	8 1/2 (216)	5 (127)	3 (76)	1 1/2 (38)	1 1/8 (29)	1 1/2 (38)
0826	2	5 by 3	2 (51)	6 (152)	9 9/16 (237)	5 1/2 (140)	3 1/2 (89)	1 1/2 (38)	1 1/8 (29)	1 1/2 (38)
0828	8	5 by 4	2 (51)	6 (152)	10 3/32 (264)	6 (152)	4 (102)	1 1/2 (38)	1 1/8 (29)	1 1/2 (38)
0830	4	5	2 (51)	6 1/2 (165)	11 7/16 (291)	6 1/2 (165)	4 1/2 (114)	1 1/2 (38)	1 1/2 (38)	2 (51)
0832	0	6 by 2	2 (51)	6 1/2 (165)	8 3/16 (208)	5 (127)	3 (76)	1 1/2 (38)	1 1/8 (29)	1 1/2 (38)
0838	0	6 by 3	2 (51)	6 1/2 (165)	9 9/16 (233)	5 1/2 (140)	3 1/2 (89)	1 1/2 (38)	1 1/8 (29)	1 1/2 (38)
0834	6	6 by 4	2 (51)	6 1/2 (165)	10 1/16 (256)	6 (152)	4 (102)	1 1/2 (38)	1 1/8 (29)	1 1/2 (38)
0835	3	6 by 5	2 (51)	7 (178)	11 1/2 (292)	6 1/2 (165)	4 1/2 (114)	1 1/2 (38)	1 1/2 (38)	2 (51)
0836	1	6	2 (51)	7 (178)	12 1/2 (318)	7 (178)	5 (127)	1 1/2 (38)	1 1/2 (38)	2 (51)
0850	2	8 by 2	2 1/2 (64)	7 1/2 (190)	9 5/16 (237)	5 1/2 (140)	3 (76)	2 (51)	1 1/8 (29)	1 1/2 (38)
0848	3	8 by 3	2 1/2 (64)	7 1/2 (190)	10 3/8 (264)	6 (152)	3 1/2 (89)	2 (51)	1 1/8 (29)	1 1/2 (38)
0846	4	8 by 4	2 1/2 (64)	7 1/2 (190)	11 1/2 (292)	6 1/2 (165)	4 (102)	2 (51)	1 1/8 (29)	1 1/2 (38)
0844	5	8 by 5	2 1/2 (64)	8 (203)	12 1/2 (318)	7 (178)	4 1/2 (114)	2 (51)	1 1/2 (38)	2 (51)
0842	6	8 by 6	2 1/2 (64)	8 (203)	13 1/2 (343)	7 1/2 (191)	5 (127)	2 (51)	1 1/2 (38)	2 (51)
0840	1	8	2 1/2 (64)	8 1/2 (216)	15 1/2 (395)	8 1/2 (216)	6 (152)	2 (51)	2 (51)	2 1/2 (64)

^A For details of barrel, spigot, and gasket positioning lug, see Fig. 1 and Fig. 2.

^B Dimensions E and F are laying lengths.

FIG. 19 Sanitary Tee Branch (corresponds to Table 24 of CISPI Specification 301)

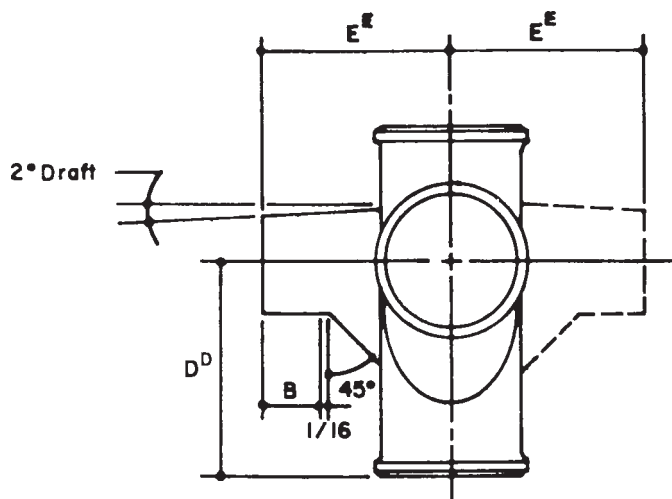
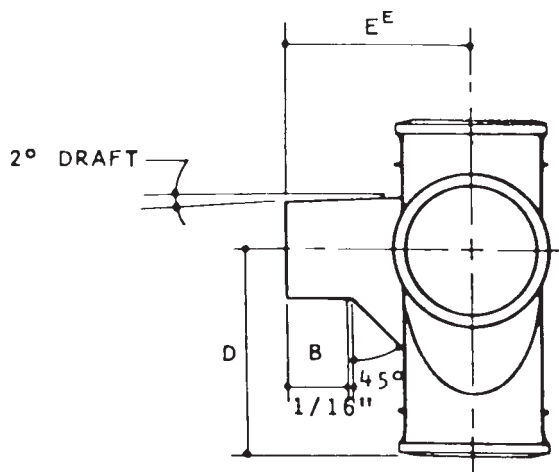

NOTE 1—Sanitary Tee branch with side inlet; illustration shows left hand. Can be furnished left or right hand.

NOTE 2—Inclusion of spigot bead and positioning lug optional with manufacturer based on casting method used.

NOTE 1—Sanitary Tee branch with side inlet; illustration shows left hand. Can be furnished left or right hand.

NOTE 2—Inclusion of spigot bead and positioning lug optional with manufacturer based on casting method used.

ASA Code Group 022		Size, in.	Dimensions, in. (mm) ^{A,B}		
Item No.	✓		B	E ^{E,C} ±1/8 (3.2)	D
0976	5	3 by 3 by 2 LH	1½ (38)	47/16 (113)	5 (127)
0986	4	3 by 3 by 2 RH	1½ (38)	47/16 (113)	5 (127)
0978	1	4 by 2 by 2 LH	1½ (38)	3¼ (83)	4½ (114)
0988	0	4 by 2 by 2 RH	1½ (38)	3¼ (83)	4½ (114)
0980	7	4 by 3 by 2 LH	1½ (38)	415/16 (125)	5 (127)
0990	6	4 by 3 by 2 RH	1½ (38)	415/16 (125)	5 (127)
0982	3	4 by 4 by 2 LH	1½ (38)	415/16 (125)	5½ (140)
0992	2	4 by 4 by 2 RH	1½ (38)	415/16 (125)	5½ (140)

ASA Code Group 022		Size, in.	Dimensions, in. (mm) ^{A,B}		
Item No.	✓		B	E ^{E,C} ±1/8 (3.2)	D
1030	0	3 by 3 by 2 LH	1½ (38)	47/16 (113)	5 (127)
1034	2	3 by 3 by 2 RH	1½ (38)	47/16 (113)	5 (127)
1037	5	3 by 3 by 2 R&L	1½ (38)	47/16 (113)	5 (127)
1032	6	4 by 4 by 2 LH	1½ (38)	415/16 (125)	5½ (140)
1036	7	4 by 4 by 2 RH	1½ (38)	415/16 (125)	5½ (140)
1038	3	4 by 4 by 2 R&L	1½ (38)	415/16 (125)	5½ (140)

^A For details of barrel, spigot, and gasket positioning lug, see Fig. 1 and Fig. 2.

^B For details of sanitary Tee branch, see Fig. 19.

^C Dimension E^E is laying length.

FIG. 20 Sanitary Tee With Right or Left Side Opening (corresponds to Table 28 of CISPI Specification 301)

^A For details of barrel, spigot, and gasket positioning lug, see Fig. 1 and Fig. 2.

^B For details of sanitary Tee branch, see Fig. 19.

^C Dimension E^E is laying length.

FIG. 21 Sanitary Tee With 2-in. Side Opening Right or Left/Right and Left (corresponds to Table 29 of CISPI Specification 301)

ASTM A 888 – 98^{e1}

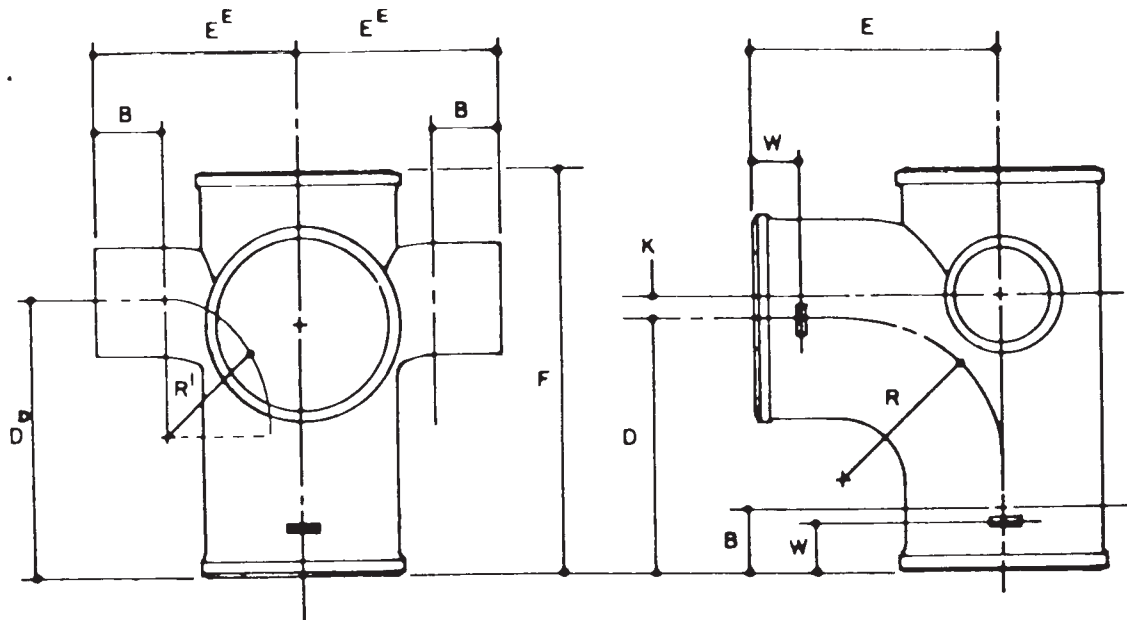

NOTE 1—Inclusion of spigot bead positioning lug optional with manufacturer based on casting methods used.

ASA Code Group 022		Dimensions, in. (mm) ^A										
Item No.	✓	Size, in.	B	E ^E B±1/8 (3.2)	E ^B ± 1/8 (3.2)	F ^B ±1/8 (3.2)	D	D ^D	K	R ^A	R	W
1058	1	3 by 3 by 2 LH	1½ (38)	4½ (114)	5 (127)	8½ (216)	5 (127)	6 (152)	1 (25)	3 (76)	3½ (89)	1⅞ (29)
1062	3	3 by 3 by 2 RH	1½ (38)	4½ (114)	5 (127)	8½ (216)	5 (127)	6 (152)	1 (25)	3 (76)	3½ (89)	1⅞ (29)
1066	4	3 by 3 by 2 R&L	1½ (38)	4½ (114)	5 (127)	8½ (216)	5 (127)	6 (152)	1 (25)	3 (76)	3½ (89)	1⅞ (29)
1060	7	4 by 4 by 2 LH	1½ (38)	5 (127)	5½ (140)	9⅞ (232)	5½ (140)	6½ (165)	1 (25)	3 (76)	4 (102)	1⅞ (29)
1064	9	4 by 4 by 2 RH	1½ (38)	5 (127)	5½ (140)	9⅞ (232)	5½ (140)	6½ (165)	1 (25)	3 (76)	4 (102)	1⅞ (29)
1068	0	4 by 4 by 2 R&L	1½ (38)	5 (127)	5½ (140)	9⅞ (232)	5½ (140)	6½ (165)	1 (25)	3 (76)	4 (102)	1⅞ (29)

^A For details of barrel, spigot, and gasket positioning lug, see Fig. 1 and Fig. 2.

^B Dimensions E, F, and E^E are laying lengths.

FIG. 22 Sanitary Tee With Side Opening Above Center Right and Left—Right or Left (New Orleans Special) (corresponds to Table 30 of CISPI Specification 301)

ASTM A 888 – 98^{e1}

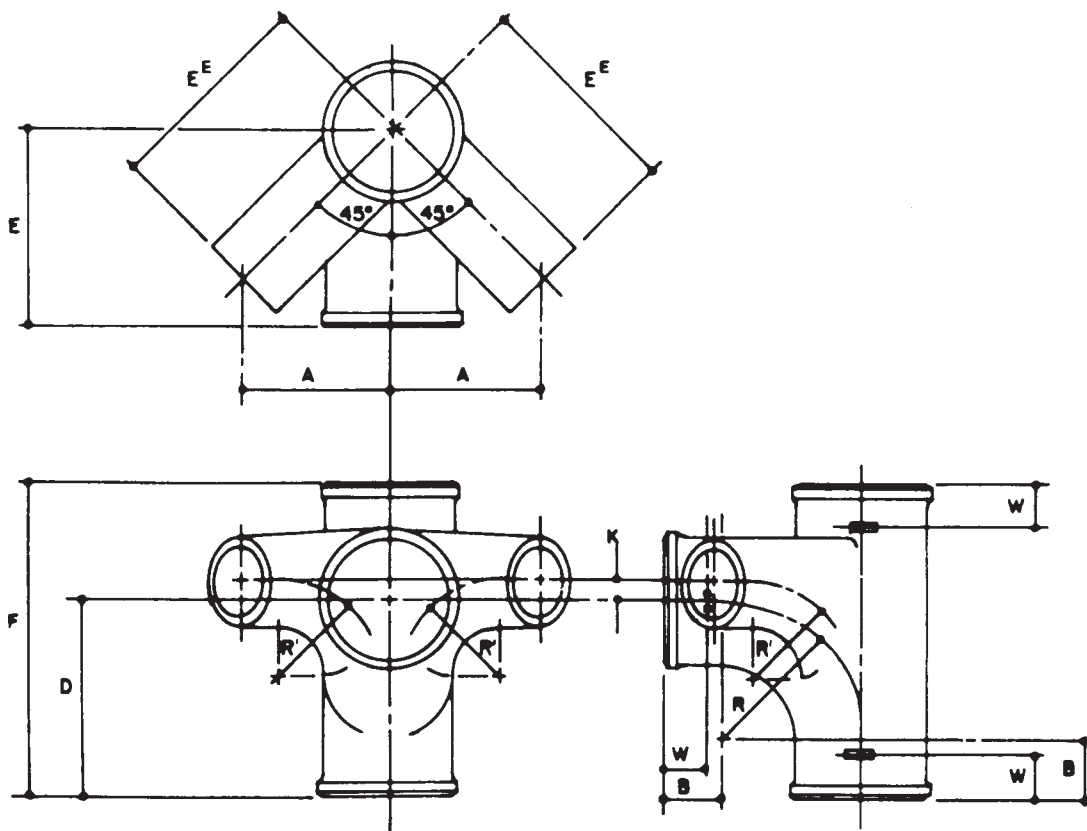

NOTE 1—Inclusion of spigot bead and positioning lug optional with manufacturer based on casting methods used.
NOTE 2—For details of Sanitary Tee ranch, see Fig. 19.

ASA Code Group 022		Dimensions, in. (mm) ^A										
Item No.	Size, in.	A	B	E ^{EB} ± ¹ / ₈ (3.2)	E ^B ± ¹ / ₈ (3.2)	F ^B ± ¹ / ₈ (3.2)	D	K	R	R'	W	
1086	2 3 by 3 by 2 LH	3 ³ / ₄ (95)	1 ¹ / ₂ (38)	5 ⁵ / ₈ (137)	5 (127)	8 (203)	5 (127)	1/2 (13)	3 ¹ / ₂ (89)	3 (76)	1 ¹ / ₈ (29)	
1090	4 3 by 3 by 2 RH	3 ³ / ₄ (95)	1 ¹ / ₂ (38)	5 ⁵ / ₈ (137)	5 (127)	8 (203)	5 (127)	1/2 (13)	3 ¹ / ₂ (89)	3 (76)	1 ¹ / ₈ (29)	
1094	6 3 by 3 by 2 by 2 R&L	3 ³ / ₄ (95)	1 ¹ / ₂ (38)	5 ⁵ / ₈ (137)	5 (127)	8 (203)	5 (127)	1/2 (13)	3 ¹ / ₂ (89)	3 (76)	1 ¹ / ₈ (29)	
						F ^B N.O. ± ¹ / ₈ (3.2)		KNO				
1122	5 3 by 3 by 2 LH	3 ³ / ₄ (95)	1 ¹ / ₂ (38)	5 ⁵ / ₈ (137)	5 (127)	8 ¹ / ₂ (216)	5 (127)	1 (25)	3 ¹ / ₂ (89)	3 (76)	1 ¹ / ₈ (29)	
1126	6 3 by 3 by 2 RH	3 ³ / ₄ (95)	1 ¹ / ₂ (38)	5 ⁵ / ₈ (137)	5 (127)	8 ¹ / ₂ (216)	5 (127)	1 (25)	3 ¹ / ₂ (89)	3 (76)	1 ¹ / ₈ (29)	
1130	8 3 by 3 by 2 R&L	3 ³ / ₄ (95)	1 ¹ / ₂ (38)	5 ⁵ / ₈ (137)	5 (127)	8 ¹ / ₂ (216)	5 (127)	1 (25)	3 ¹ / ₂ (89)	3 (76)	1 ¹ / ₈ (29)	
1124	1 4 by 4 by 2 LH	4 ⁵ / ₁₆ (110)	1 ¹ / ₂ (38)	6 ¹ / ₈ (156)	5 ¹ / ₂ (140)	9 ¹ / ₈ (232)	5 ¹ / ₂ (140)	1 (25)	4 (102)	3 (76)	1 ¹ / ₈ (29)	
1128	2 4 by 4 by 2 RH	4 ⁵ / ₁₆ (110)	1 ¹ / ₂ (38)	6 ¹ / ₈ (156)	5 ¹ / ₂ (140)	9 ¹ / ₈ (232)	5 ¹ / ₂ (140)	1 (25)	4 (102)	3 (76)	1 ¹ / ₈ (29)	
1132	4 4 by 4 by 2 R&L	4 ⁵ / ₁₆ (110)	1 ¹ / ₂ (38)	6 ¹ / ₈ (156)	5 ¹ / ₂ (140)	9 ¹ / ₈ (232)	5 ¹ / ₂ (140)	1 (25)	4 (102)	3 (76)	1 ¹ / ₈ (29)	

^A For details of barrel, spigot, and gasket positioning lug, see Fig. 1 and Fig. 2.

^B Dimensions E, F, and E^E are laying lengths.

FIG. 23 Sanitary Tee With 45° Slide Openings Above Center Right or Left or Right and Left^B and New Orleans Specials (corresponds to Table 31 of CISPI Specification 301)

ASTM A 888 – 98^{e1}

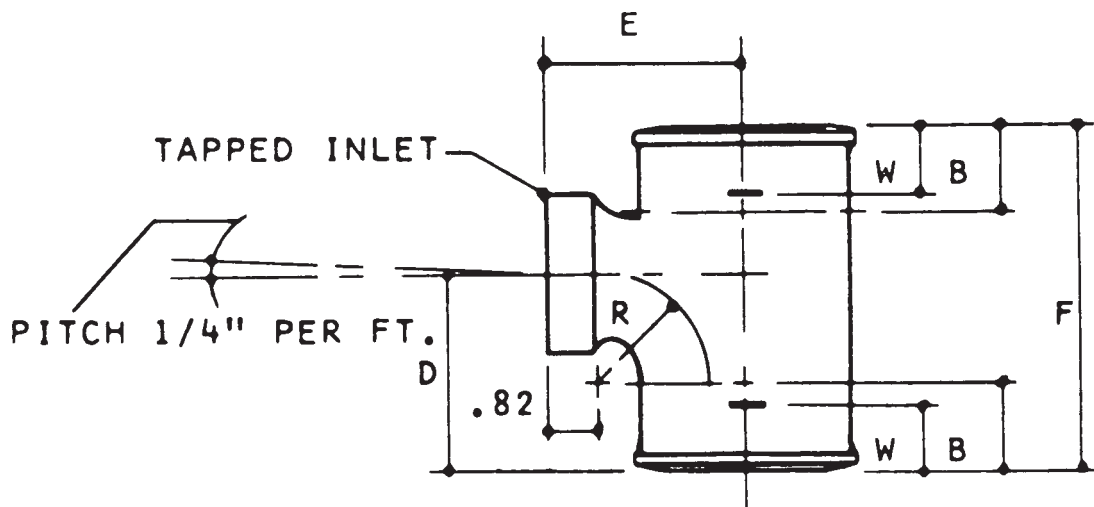

ASA Code Group 022			Dimensions, in. (mm) ^A						
Item No.	✓	Size, in.	B	E	F ^B ± 1/8 (3.2)	D	R	IPS Tapping ^C	W
1208	2	1½ by 1¼	1½ (38)	2 ⁹ / ₁₆ (65)	5 ¹¹ / ₁₆ (144)	3¼ (83)	1¾ (44)	1¼ (32)	1½ (29)
1210	8	1½ by 1½	1½ (38)	2 ⁹ / ₁₆ (65)	5 ¹¹ / ₁₆ (144)	3¼ (83)	1¾ (44)	1½ (38)	1½ (29)
1212	4	2 by 1¼	1½ (38)	2 ¹³ / ₁₆ (71)	5 ¹¹ / ₁₆ (144)	3¼ (83)	1¾ (44)	1¼ (32)	1½ (29)
1214	0	2 by 1½	1½ (38)	2 ¹³ / ₁₆ (71)	5 ¹¹ / ₁₆ (144)	3¼ (83)	1¾ (44)	1½ (38)	1½ (29)
1216	5	2 by 2	1½ (38)	3 ¹ / ₁₆ (78)	6 ³ / ₈ (162)	3¾ (95)	2¼ (57)	2 (51)	1½ (29)
1218	1	3 by 1¼	1½ (38)	3 ⁵ / ₁₆ (84)	5 ¹¹ / ₁₆ (144)	3¼ (83)	1¾ (44)	1¼ (32)	1½ (29)
1220	7	3 by 1½	1½ (38)	3 ⁵ / ₁₆ (84)	5 ¹¹ / ₁₆ (144)	3¼ (83)	1¾ (44)	1½ (38)	1½ (29)
1222	3	3 by 2	1½ (38)	3 ⁹ / ₁₆ (90)	6 ³ / ₈ (162)	3¾ (95)	2¼ (57)	2 (51)	1½ (29)
1223	1	3 by 3	1½ (38)	4 ³ / ₁₆ (106)	8 (203)	4 ⁷ / ₈ (124)	3½ (89)	3 (76)	1½ (29)
1224	9	4 by 1¼	1½ (38)	3 ¹³ / ₁₆ (97)	5 ¹¹ / ₁₆ (144)	3¼ (83)	1¾ (44)	1¼ (32)	1½ (29)
1226	4	4 by 1½	1½ (38)	3 ¹³ / ₁₆ (97)	5 ¹¹ / ₁₆ (144)	3¼ (83)	1¾ (44)	1½ (38)	1½ (29)
1228	0	4 by 2	1½ (38)	4 ¹ / ₁₆ (103)	6 ³ / ₈ (162)	3¾ (95)	2¼ (57)	2 (51)	1½ (29)
1231	4	5 by 1¼	2 (51)	4 ⁵ / ₁₆ (109)	6 ¹¹ / ₁₆ (170)	3¾ (95)	1¾ (44)	1¼ (32)	1½ (38)
1232	2	5 by 1½	2 (51)	4 ⁵ / ₁₆ (109)	6 ¹¹ / ₁₆ (170)	3¾ (95)	1¾ (44)	1½ (38)	1½ (38)
1233	0	5 by 2	2 (51)	4 ⁹ / ₁₆ (109)	7 ¹⁵ / ₁₆ (202)	4¼ (108)	2¼ (57)	2 (51)	1½ (38)

^A For details of barrel, spigot, and gasket positioning lug, see Fig. 1 and Fig. 2.

^B Dimension F is laying length.

^C For details of tapping bosses, see Fig. 62.

FIG. 24 Sanitary Tapped Tee (corresponds to Table 32 of CISPI Specification 301)

ASTM A 888 – 98^{e1}

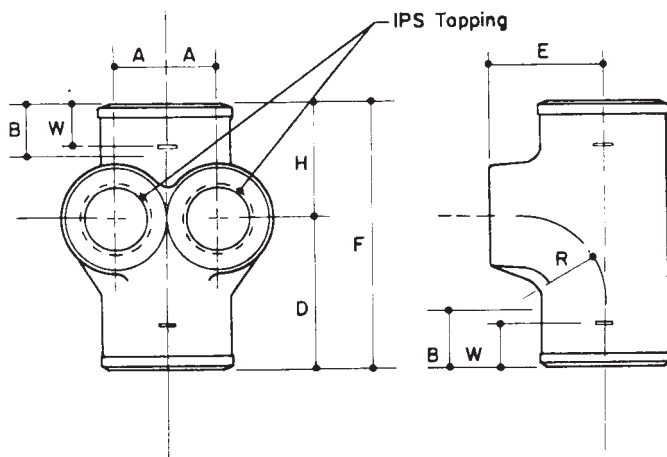

NOTE 1—Horizontal inlet waste bosses to be tapped at an angle of 1/4 in. (6 mm) per foot to provide flow.

ASA Code Group 022		Size, in.	Dimensions, in. (mm) ^A									
Item No.	✓		B	H	E	F ^B ± 1/8 (3.2)	D	A	R	W	IPS Tapping ^C	
1290	0	2 by 1 1/2	1 1/2 (38)	3 (76)	2 1/2 (64)	7 (178)	4 (102)	1 3/8 (35)	2 1/4 (57)	1 1/8 (29)	1 1/2 (38)	
1292	6	3 by 1 1/2	1 1/2 (38)	3 (76)	3 (76)	7 (178)	4 (102)	1 3/8 (35)	2 1/4 (57)	1 1/8 (29)	1 1/2 (38)	
1294	2	4 by 1 1/2	1 1/2 (38)	3 (76)	3 1/2 (89)	7 (178)	4 (102)	1 3/8 (35)	2 1/4 (57)	1 1/8 (29)	1 1/2 (38)	

^A For details of barrel, spigot, and gasket positioning lug, see Fig. 1 and Fig. 2.

^B Dimension F is laying length.

^C For details of tapping bosses, see Fig. 62.

FIG. 25 Horizontal Twin Sanitary Tapped Tee (corresponds to Table 37 of CISPI Specification 301)

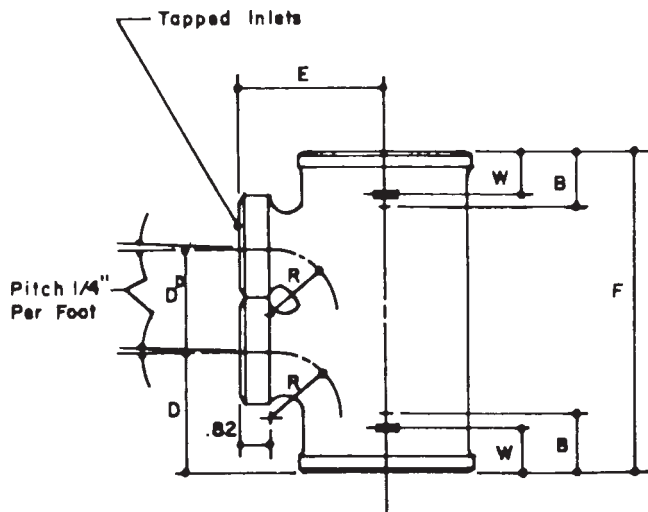

ASA Code Group 022		Size, in.	Dimensions, in. (mm) ^A							
Item No.	✓		B	E	F ^B ± 1/8 (3.2)	D	D ^D	R	IPS Tapping ^C	W
1304	9	2 by 1 1/2	1 1/2 (38)	2 13/16 (71)	8 7/16 (214)	3 1/4 (83)	2 3/4 (70)	1 3/4 (44)	1 1/2 (38)	1 1/8 (29)
1306	4	3 by 1 1/2	1 1/2 (38)	3 5/16 (84)	8 7/16 (214)	3 1/4 (83)	2 3/4 (70)	1 3/4 (44)	1 1/2 (38)	1 1/8 (29)

^A For details of barrel, spigot, and gasket positioning lug, see Fig. 1 and Fig. 2.

^B Dimension F is laying length.

^C For details of tapping bosses, see Fig. 62.

FIG. 26 Double Vertical Sanitary Tapped Tee (corresponds to Table 38 of CISPI Specification 301)

ASTM A 888 – 98^{e1}

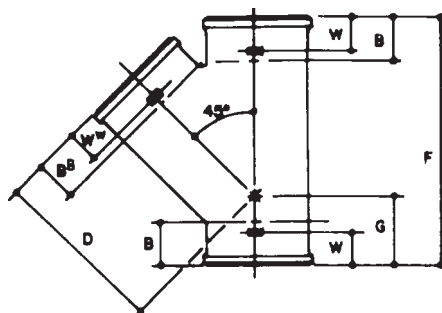

ASA Code Group 022			Dimensions, in. (mm) ^A						
Item No.	√	Size, in.	B	B ^B	D ^B ± 1/8(3.2)	F ^B ± 1/8 (3.2)	G	W	W ^W
1312	2	1½	1½ (38)	1½ (38)	4 (102)	6 (152)	2 (51)	1⅞ (29)	1⅞ (29)
1314	8	2	1½ (38)	1½ (38)	4⅝ (117)	6⅝ (168)	2 (51)	1⅞ (29)	1⅞ (29)
1316	3	3 by 2	1½ (38)	1½ (38)	5⅞ (135)	6⅞ (168)	1½ (38)	1⅞ (29)	1⅞ (29)
1318	9	3	1½ (38)	1½ (38)	5¾ (146)	8 (203)	2¼ (57)	1⅞ (29)	1⅞ (29)
1320	5	4 by 2	1½ (38)	1½ (38)	6 (152)	6⅞ (168)	1 (25)	1⅞ (29)	1⅞ (29)
1322	1	4 by 3	1½ (38)	1½ (38)	6½ (165)	8 (203)	1⅞ (43)	1⅞ (29)	1⅞ (29)
1324	7	4	1½ (38)	1½ (38)	7⅞ (179)	9½ (241)	2⅞ (62)	1⅞ (29)	1⅞ (29)
1326	2	5 by 2	2 (51)	1½ (38)	7½ (191)	8⅞ (205)	1⅞ (43)	1½ (38)	1⅞ (29)
1328	8	5 by 3	2 (51)	1½ (38)	8 (203)	9⅞ (246)	1⅞ (43)	1½ (38)	1⅞ (29)
1330	4	5 by 4	2 (51)	1½ (38)	8½ (216)	11⅞ (284)	2⅞ (62)	1½ (38)	1⅞ (29)
1332	0	5	2 (51)	2 (51)	9½ (241)	12⅞ (321)	3⅞ (79)	1½ (38)	1½ (38)
1334	6	6 by 2	2 (51)	1½ (38)	8¼ (210)	8⅞ (211)	½ (13)	1½ (38)	1⅞ (29)
1336	1	6 by 3	2 (51)	1½ (38)	8¾ (222)	9¾ (248)	1¼ (32)	1½ (38)	1⅞ (29)
1338	7	6 by 4	2 (51)	1½ (38)	9¼ (235)	11⅞ (284)	1⅞ (43)	1½ (38)	1⅞ (29)
1340	3	6 by 5	2 (51)	2 (51)	10¼ (260)	12½ (318)	2⅞ (65)	1½ (38)	1½ (38)
1342	9	6	2 (51)	2 (51)	10¾ (273)	14⅞ (357)	3⅞ (84)	1½ (38)	1½ (38)
1344	5	8 by 2	2½ (64)	2¼ (57)	9⅞ (238)	8½ (216)	9/16 (14)	2 (25)	1⅞ (29)
1346	0	8 by 3	2½ (64)	2¼ (57)	9⅞ (238)	9⅞ (238)	1/8 (3)	2 (25)	1⅞ (29)
1348	6	8 by 4	2½ (64)	2¼ (57)	10⅞ (264)	11⅞ (291)	1⅞ (43)	2 (25)	1⅞ (29)
1350	2	8 by 5	2½ (64)	2¾ (70)	11⅞ (289)	12⅞ (325)	1⅞ (43)	2 (25)	1½ (38)
1352	8	8 by 6	2½ (64)	2¾ (70)	11⅞ (289)	14⅞ (360)	2⅞ (62)	2 (25)	1½ (38)
1354	4	8	2½ (64)	3¼ (83)	13⅞ (340)	17⅞ (435)	3¾ (95)	2 (25)	2 (51)
1357	7	10 by 4	3 (76)	1½ (38)	11⅞ (297)	12⅞ (321)	¾ (19)	2 (25)	1⅞ (29)
1359	3	10 by 6	3 (76)	2 (51)	13⅞ (333)	15⅞ (392)	2⅞ (62)	2 (25)	1½ (38)
1360	0	10 by 8	3 (76)	2½ (64)	14⅞ (360)	18⅞ (467)	3⅞ (79)	2 (25)	2 (51)
1361	9	10	3 (76)	3¾ (95)	16½ (419)	21½ (546)	5⅞ (129)	2 (25)	2 (51)
1362	9	12	3¼ (83)	3¼ (83)	19¾ (502)	25½ (648)	5¾ (146)	2¾ (70)	2¾ (70)
1363	9	15	3¼ (83)	3¼ (83)	23¼ (591)	30 (762)	6¾ (171)	2¾ (70)	2¾ (70)

^A For details of barrel, spigot, and gasket positioning lug, see Fig. 1 and Fig. 2.

^B Dimensions D and F are laying lengths.

FIG. 27 Wye (corresponds to Table 39 of CISPI Specification 301)

ASTM A 888 - 98^{e1}

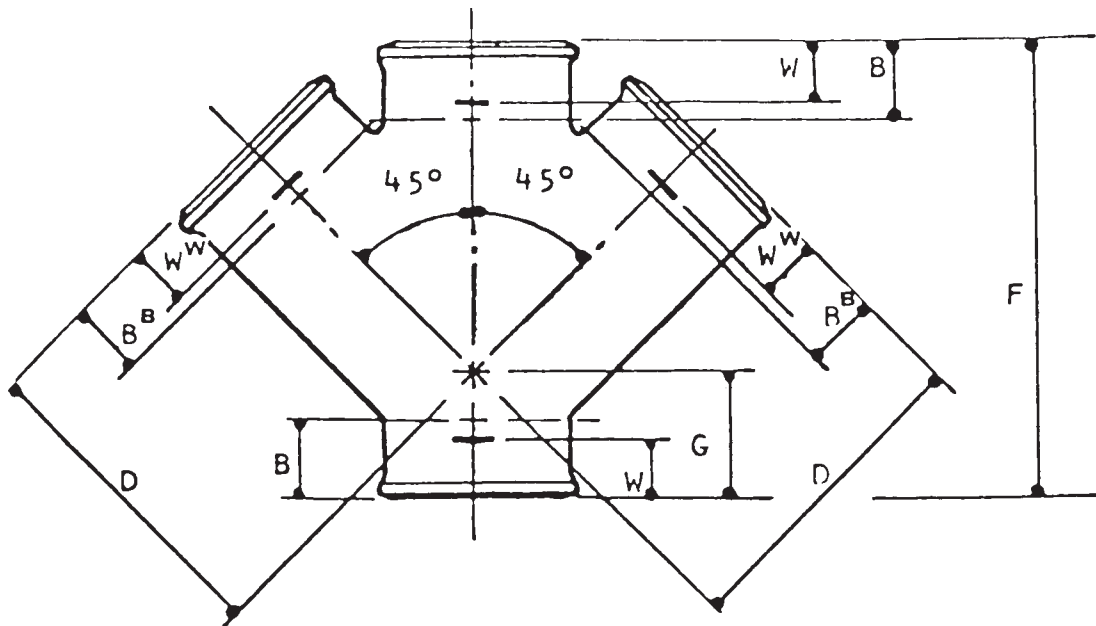

ASA Code Group 022		Dimensions, in. (mm) ^A							
Item No.	√	Size, in.	B	B ^B	D ^B ± 1/8 (3.2)	F ^B ± 1/8 (3.2)	G	W	W ^W
1538	2	2	1½ (38)	1½ (38)	4⅝ (117)	6⅝ (168)	2 (51)	1⅝ (29)	1⅝ (29)
1540	8	3 by 2	1½ (38)	1½ (38)	5⅝ (135)	6⅝ (168)	1½ (38)	1⅝ (29)	1⅝ (29)
1542	4	3	1½ (38)	1½ (38)	5¾ (146)	8 (203)	2¼ (57)	1⅝ (29)	1⅝ (29)
1544	0	4 by 2	1½ (38)	1½ (38)	6 (152)	6⅝ (168)	1 (25)	1⅝ (29)	1⅝ (29)
1546	5	4 by 3	1½ (38)	1½ (38)	6½ (165)	8 (203)	1⅞ (43)	1⅝ (29)	1⅝ (29)
1548	1	4	1¼ (32)	1½ (38)	7⅞ (179)	9½ (241)	2⅞ (62)	1⅝ (29)	1⅝ (29)
1550	7	5 by 4	2 (51)	1½ (38)	8½ (216)	11⅜ (284)	2⅞ (62)	1½ (38)	1⅝ (29)
1552	3	6 by 4	2 (51)	1½ (38)	9¼ (235)	11⅜ (284)	1⅞ (49)	1½ (38)	1⅝ (29)
1554	9	6	2 (51)	2 (51)	10¾ (273)	14⅞ (357)	3⅞ (84)	1½ (38)	1½ (38)
1556	3	8 by 4	2½ (64)	2¼ (57)	10¾ (264)	11⅞ (291)	1⅞ (43)	2 (51)	1⅝ (29)
1557	1	8 by 6	2½ (64)	2¾ (70)	11⅞ (300)	14⅞ (360)	2⅞ (59)	2 (51)	1½ (38)
1558	0	8	2½ (64)	3¼ (83)	13⅞ (340)	17⅞ (435)	3¾ (95)	2 (51)	2 (51)

^A For details of barrel, spigot, and gasket positioning lug, see Fig. 1 and Fig. 2.

^B Dimensions D and F are laying lengths.

FIG. 28 Double Wye (corresponds to Table 42 of CISPI Specification 301)

ASTM A 888 – 98^{e1}

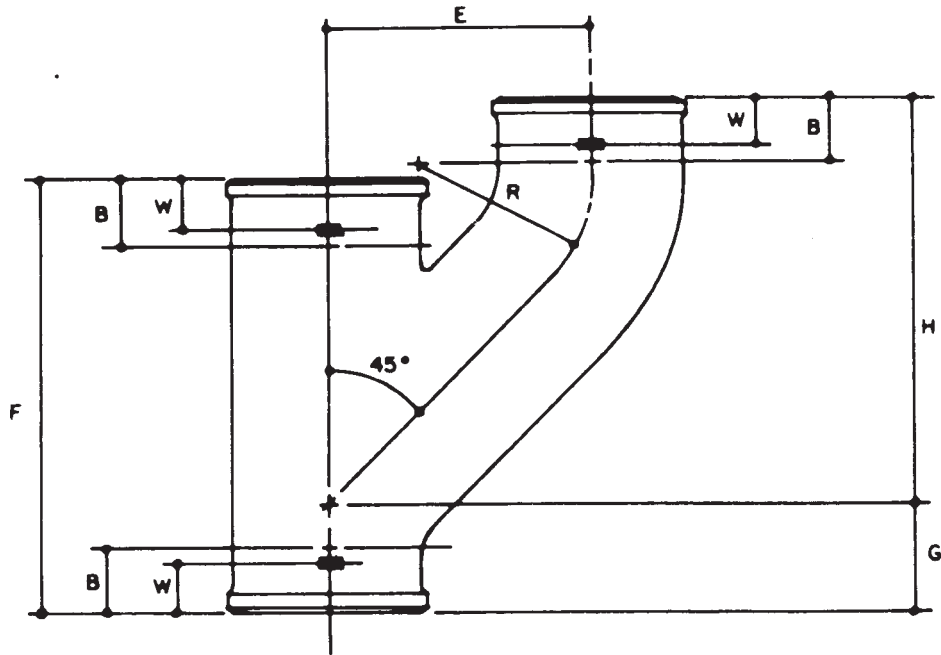

ASA Code Group 022		Size, in.	Dimensions, in. (mm) ^A						
Item No.	√		B	H	E	F ^B (±1/8)	G	R	W
1646	3	2	1½ (38)	8¼ (210)	5½ (140)	7 (178)	2 (51)	3 (76)	1⅝ (29)
1648	9	3 by 2	1½ (38)	8¾ (208)	5½ (140)	7 (178)	1½ (38)	3 (76)	1⅝ (29)
1650	5	3	1½ (38)	8⅞ (214)	5½ (140)	8⅜ (86)	2⅜ (56)	3½ (89)	1⅝ (29)
1652	1	4 by 2	1½ (38)	8¼ (210)	5½ (140)	7 (178)	1 (25)	3 (76)	1⅝ (29)
1654	7	4 by 3	1½ (38)	8⅞ (214)	5½ (140)	8⅜ (86)	1⅞ (43)	3½ (89)	1⅝ (29)
1656	2	4	1½ (38)	9⅞ (232)	6 (152)	9¾ (248)	2⅞ (62)	4 (102)	1⅝ (29)

^A For details of barrel, spigot, and gasket positioning lug, see Fig. 1 and Fig. 2.

^B Dimension F is laying length.

FIG. 29 Upright Wye (corresponds to Table 45 of CISPI Specification 301)

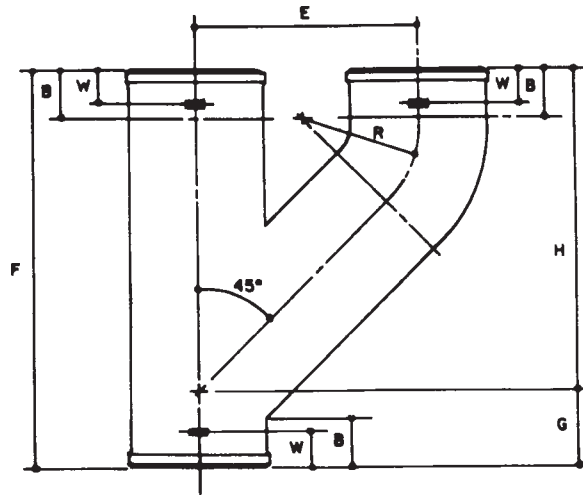

ASA Code Group 022		Size, in.	Dimensions, in. (mm) ^A							
Item No.	√		B	H	E	$F^{B \pm 1/8}$ (3.2)	G	R	W	
022 9000	5	3 by 3	1½ (38)	10 (254)	7 (178)	12¼ (311)	2¼ (57)	3½ (89)	1⅝ (29)	
022 9001	3	4 by 3	1½ (38)	10 (254)	7 (178)	11⅞ (297)	1⅞ (43)	3½ (89)	1⅝ (29)	
022 9002	1	4 by 4	1½ (38)	10⅞ (257)	7 (178)	12⅞ (319)	2⅞ (62)	4 (102)	1⅝ (29)	

^A For details of barrel, spigot, and gasket positioning lug, see Fig. 1 and Fig. 2.

^B Dimensions F is laying length.

FIG. 30 Upright Wye Wide Center—Florida Special (corresponds to Table 46 of CISPI Specification 301)

ASTM A 888 – 98^{e1}

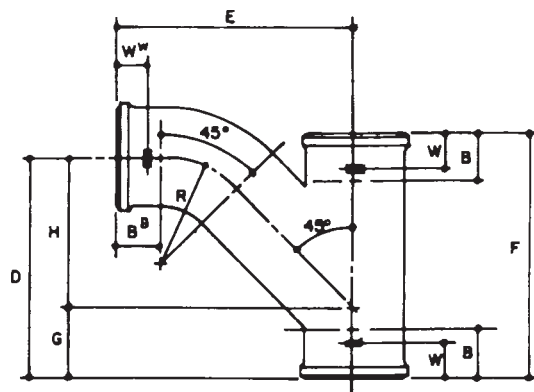

ASA Code Group 022		Dimensions, in. (mm) ^A										
Item No.	Size, in.	B	B ^B	D	E ^B ± 1/8 (3.2)	F ^B ± 1/8 (3.2)	G	H	R	W	W ^W	
1694	3 1 1/2	1 1/2 (38)	1 1/2 (38)	4 3/4 (121)	5 3/8 (137)	6 (152)	2 (51)	2 3/4 (70)	2 3/4 (70)	1 1/8 (29)	1 1/8 (29)	
1696	8 2 by 1 1/2	1 1/2 (38)	1 1/2 (38)	5 (127)	5 7/8 (149)	6 (152)	2 (51)	3 (76)	2 3/4 (70)	1 1/8 (29)	1 1/8 (29)	
1698	4 2	1 1/2 (38)	1 1/2 (38)	5 3/8 (137)	6 1/8 (156)	6 3/8 (168)	2 (51)	3 3/8 (86)	3 (76)	1 1/8 (29)	1 1/8 (29)	
1700	8 3 by 2	1 1/2 (38)	1 1/2 (38)	5 1/2 (140)	6 3/4 (171)	6 5/8 (168)	1 1/2 (38)	4 (102)	3 (76)	1 1/8 (29)	1 1/8 (29)	
1702	4 3	1 1/2 (38)	1 1/2 (38)	7 5/16 (186)	8 (203)	8 (203)	2 1/4 (57)	5 1/16 (129)	3 1/2 (89)	1 1/8 (29)	1 1/8 (29)	
1704	0 4 by 2	1 1/2 (38)	1 1/2 (38)	5 1/2 (140)	7 1/4 (184)	6 5/8 (168)	1 (25)	4 1/2 (114)	3 (76)	1 1/8 (29)	1 1/8 (29)	
1706	5 4 by 3	1 1/2 (38)	1 1/2 (38)	7 1/4 (184)	8 1/2 (216)	8 (203)	1 11/16 (49)	5 9/16 (141)	3 1/2 (89)	1 1/8 (29)	1 1/8 (29)	
1708	1 4	1 1/2 (38)	1 1/2 (38)	9 1/4 (235)	10 (254)	9 1/2 (241)	2 7/16 (62)	6 13/16 (173)	4 (102)	1 1/8 (29)	1 1/8 (29)	
1710	7 5 by 2	2 (51)	1 1/2 (38)	5 15/16 (151)	7 3/4 (197)	8 1/16 (205)	1 5/16 (24)	5 (127)	3 (76)	1 1/2 (38)	1 1/8 (29)	
1712	3 5 by 3	2 (51)	1 1/2 (38)	7 3/4 (197)	9 (229)	9 1/16 (246)	1 11/16 (43)	6 1/16 (154)	3 1/2 (89)	1 1/2 (38)	1 1/8 (29)	
1714	9 5 by 4	2 (51)	1 1/2 (38)	9 3/4 (248)	10 1/2 (267)	11 3/16 (284)	2 7/16 (62)	7 5/16 (186)	4 (102)	1 1/2 (38)	1 1/8 (29)	
1716	4 5	2 (51)	2 (51)	11 3/4 (298)	12 1/2 (318)	12 5/8 (321)	3 1/8 (79)	8 5/8 (219)	4 1/2 (114)	1 1/2 (38)	1 1/2 (38)	
1718	0 6 by 2	2 (51)	6 (152)	8 1/4 (210)	8 5/16 (211)	1/2 (13)	5 1/2 (140)	3 (76)	1 1/2 (38)	1 1/2 (38)	1 1/8 (29)	
1720	6 6 by 3	2 (51)	1 1/2 (38)	7 13/16 (198)	9 1/2 (241)	9 3/4 (248)	1 1/4 (32)	6 9/16 (167)	3 1/2 (89)	1 1/2 (38)	1 1/8 (29)	
1722	2 6 by 4	2 (51)	1 1/2 (38)	9 3/4 (248)	11 (279)	11 3/16 (284)	1 15/16 (49)	7 13/16 (198)	4 (102)	1 1/2 (38)	1 1/8 (29)	
1724	8 6 by 5	2 (51)	2 (51)	14 11/16 (373)	13 (330)	12 1/2 (318)	2 9/16 (65)	9 1/8 (232)	4 1/2 (114)	1 1/2 (38)	1 1/2 (38)	
1726	3 6	2 (51)	2 (51)	13 5/8 (346)	14 3/8 (365)	14 1/16 (357)	3 5/16 (84)	10 5/16 (262)	5 (127)	1 1/2 (38)	1 1/2 (38)	
1728	9 8 by 4	2 1/2 (64)	1 1/2 (38)	9 7/16 (240)	11 5/16 (287)	11 3/16 (284)	7/8 (22)	8 9/16 (217)	4 (102)	2 (51)	1 1/8 (29)	
1730	5 8 by 5	2 1/2 (64)	2 (51)	10 15/16 (278)	12 13/16 (325)	12 11/16 (322)	1 5/8 (41)	9 5/16 (237)	4 1/2 (114)	2 (51)	1 1/2 (38)	
1732	1 8 by 6	2 1/2 (64)	2 (51)	12 (305)	13 3/8 (340)	13 5/16 (354)	2 1/4 (57)	9 3/4 (248)	5 (127)	2 (51)	1 1/2 (38)	
1734	7 8	2 1/2 (64)	2 1/2 (64)	14 3/4 (375)	15 5/16 (395)	16 15/16 (430)	3 3/4 (95)	11 (279)	6 (152)	2 (51)	2 (51)	

^A For details of barrel, spigot, and gasket positioning lug, see Fig. 1 and Fig. 2.

^B Dimensions E and F are laying lengths.

FIG. 31 Combination Wye and 1/8 Bend (corresponds to Table 47 of CISPI Specification 301)

ASTM A 888 – 98^{e1}

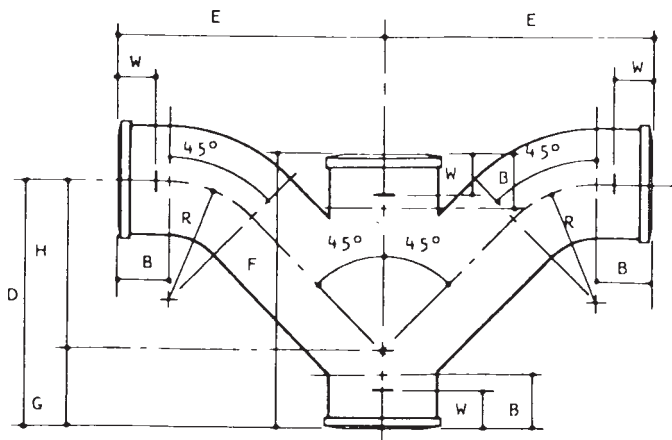

ASA Code Group 022			Dimensions, in. (mm) ^A							
Item No.	✓	Size, in.	B	D	$E^B \pm \frac{1}{8}$ (3.2)	$F^B \pm \frac{1}{8}$ (3.2)	G	H	R	W
1802	2	2	1½ (38)	5⅜ (137)	6⅛ (156)	6⅝ (168)	2 (51)	3⅜ (86)	3 (76)	1⅝ (29)
1804	8	3 by 2	1½ (38)	5½ (140)	6¾ (171)	6⅝ (168)	1½ (38)	4 (102)	3 (76)	1⅝ (29)
1806	3	3	1½ (38)	7⅞ (186)	8 (203)	8 (203)	2¼ (57)	5⅞ (129)	3½ (89)	1⅝ (29)
1808	9	4 by 2	1½ (38)	5½ (140)	7¼ (184)	6⅝ (168)	1 (25)	4½ (114)	3 (76)	1⅝ (29)
1810	5	4 by 3	1½ (38)	7¼ (184)	8½ (216)	8 (203)	1⅞ (43)	5⅞ (141)	3½ (89)	1⅝ (29)
1812	1	4	1½ (38)	9¼ (235)	10 (254)	9½ (241)	2⅞ (62)	6⅞ (173)	4 (102)	1⅝ (29)

^A For details of barrel, spigot, and gasket positioning lug, see Fig. 1 and Fig. 2.

^B Dimensions E and F are laying lengths.

FIG. 32 Combination Wye and 1/8 Bend, Double (corresponds to Table 50 of CISPI Specification 301)

ASTM A 888 – 98^{e1}

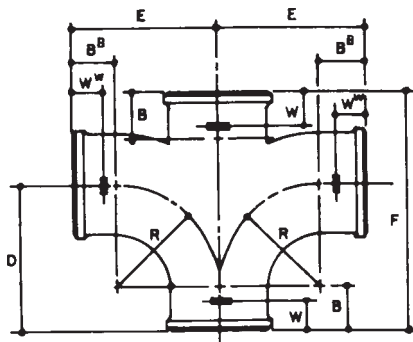

ASA Code Group 022		Size, in.	Dimensions, in. (mm) ^A							
Item No.	✓		B	E ^B ± 1/8 (3.2)	F ^B ± 1/8 (3.2)	D	R	W	WW	W ^B
1850	1	1 1/2	1 1/2 (38)	4 1/4 (108)	6 1/2 (165)	4 1/4 (108)	2 3/4 (70)	1 1/8 (29)	1 1/8 (29)	1 1/2 (38)
1852	7	2	1 1/2 (38)	4 1/2 (114)	6 7/8 (175)	4 1/2 (114)	3 (76)	1 1/8 (29)	1 1/8 (29)	1 1/2 (38)
1854	3	3 by 2	1 1/2 (38)	5 (127)	6 7/8 (175)	4 1/2 (114)	3 (76)	1 1/8 (29)	1 1/8 (29)	1 1/2 (38)
1856	8	3	1 1/2 (38)	5 (127)	8 (203)	5 (127)	3 1/2 (89)	1 1/8 (29)	1 1/8 (29)	1 1/2 (38)
1958	4	4 by 2	1 1/2 (38)	5 1/2 (140)	6 7/8 (175)	4 1/2 (114)	3 (76)	1 1/8 (29)	1 1/8 (29)	1 1/2 (38)
1860	0	4 by 3	1 1/2 (38)	5 1/2 (140)	8 (203)	5 (127)	3 1/2 (89)	1 1/8 (29)	1 1/8 (29)	1 1/2 (38)
1862	6	4	1 1/2 (38)	5 1/2 (140)	9 1/8 (232)	5 1/2 (140)	4 (102)	1 1/8 (29)	1 1/8 (29)	1 1/2 (38)
1868	3	6 by 2	2 (51)	6 1/2 (165)	8 3/16 (208)	5 (127)	3 (76)	1 1/2 (38)	1 1/8 (29)	1 1/2 (38)
1864	2	6 by 4	2 (51)	6 1/2 (165)	10 1/16 (256)	6 (152)	4 (102)	1 1/2 (38)	1 1/8 (29)	1 1/2 (38)
1867	5	6	2 (51)	7 (178)	12 1/2 (318)	7 (178)	5 (127)	1 1/2 (38)	1 1/2 (38)	2 (51)
1874	1	8 by 4	2 1/2 (64)	7 1/2 (191)	11 1/2 (292)	6 1/2 (165)	4 (102)	2 (51)	1 1/8 (29)	1 1/2 (38)
1878	2	8	2 1/2 (64)	8 1/2 (216)	15 1/2 (394)	8 1/2 (216)	6 (152)	2 (51)	2 (51)	2 1/2 (64)

^A For details of barrel, spigot, and gasket positioning lug, see Fig. 1 and Fig. 2.

^B Dimensions E and F are laying lengths.

FIG. 33 Sanitary Cross (corresponds to Table 51 of CISPI Specification 301)

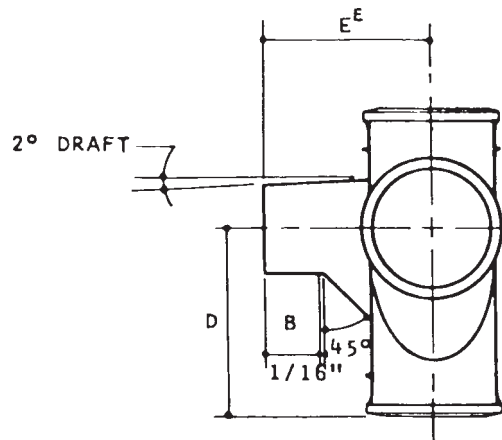

NOTE 1—Inclusion of spigot bead and positioning lug optional with manufacturer based on casting method used.

ASA Code Group 022		Size, in.	Dimensions, in. (mm) ^{A,B}		
Item No.	✓		B	E ^{E,C} ± 1/8 (3.2)	D
1898	0	3 by 3 by 2	1 1/2 (38)	4 7/16 (113)	5 (127)
1900	4	4 by 4 by 2	1 1/2 (38)	4 15/16 (125)	5 1/2 (140)

^A For details of barrel, spigot, and gasket positioning lug, see Fig. 1 and Fig. 2.

^B For details of sanitary cross, see Fig. 33.

^C Dimension E^E is laying length.

FIG. 34 Sanitary Cross With Side Opening (corresponds to Table 52 of CISPI Specification 301)

ASTM A 888 – 98^{e1}

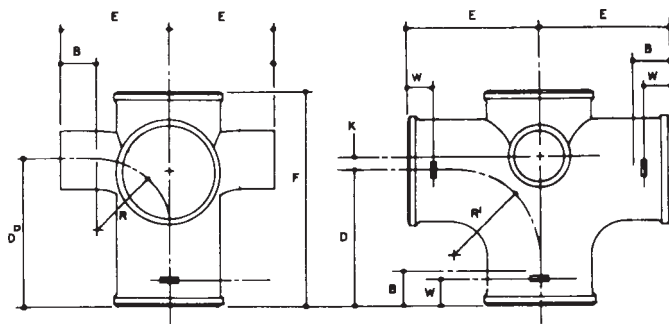

NOTE 1—Inclusion of spigot bead and positioning lug optional with manufacturer based on casting method used.

ASA Code Group 022		Size, in.	Dimensions, in. (mm) ^A									
Item No.	✓		B	E ^{EB} ±1/8 (3.2)	E ^B ±1/8 (3.2)	F ^B ±1/8 (3.2)	D	D ^D	K	R	R'	W
1982	2	3 by 3 by 2	1 1/2 (38)	4 1/2 (114)	5 (127)	8 1/2 (216)	5 (127)	6 (152)	1 (25)	3 (76)	3 1/2 (89)	1 1/8 (29)
1984	8	4 by 4 by 2	1 1/2 (38)	5 (127)	5 1/2 (140)	9 1/8 (232)	5 1/2 (140)	6 1/2 (165)	1 (25)	3 (76)	4 (102)	1 1/8 (29)

^A For details of barrel, spigot, and gasket positioning lug, see Fig. 1 and Fig. 2.

^B Dimensions E, F, and E^E are laying lengths.

FIG. 35 Sanitary Cross With Side Openings Above Center (New Orleans) (corresponds to Table 55 of CISPI Specification 301)

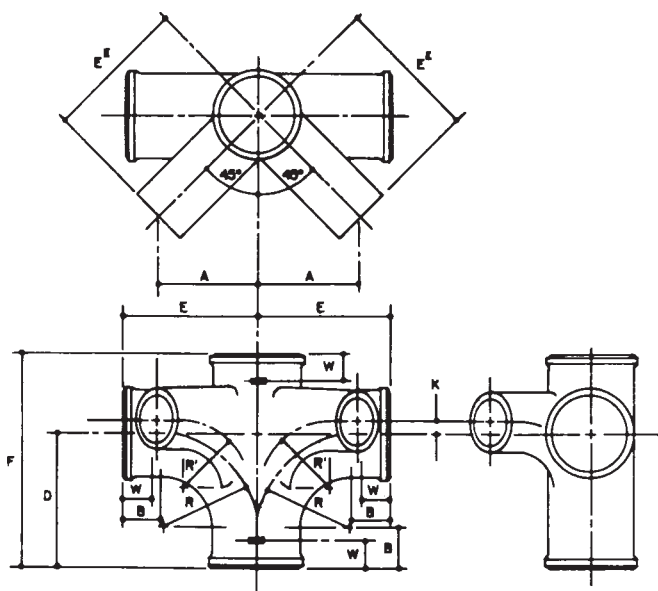

NOTE 1—Inclusion of spigot bead and positioning lug shall be optional with manufacturer based on casting method used.

NOTE 2—For details of sanitary cross, see Fig. 33.

ASA Code Group 022		Size, in.	Dimensions, in. (mm) ^A											
Item No.	✓		A	B	E ^{EB} ± 1/8 (3.2)	E ^B ± 1/8 (3.2)	F ^B ± 1/8 (3.2)	F ^B N.O.	D	K	K N.O.	R	R'	W
1994	7	3 by 3 by 2	3 3/4 (95)	1 1/2 (38)	5 3/8 (137)	5 (127)	8 (203)	8 1/2 (216)	5 (127)	1 (25)	1 (25)	3 1/2 (89)	3 (76)	1 1/8 (29)
2000	2	4 by 4 by 2	4 5/16 (110)	1 1/2 (38)	6 1/8 (156)	5 1/2 (140)	9 1/8 (232)	9 1/8 (232)	5 1/2 (140)	1/2 (13)	1 (25)	4 (102)	3 (76)	1 1/8 (29)

^A For details of barrel, spigot, and gasket positioning lug, see Fig. 1 and Fig. 2.

^B Dimensions E, F, and E^E are laying lengths.

FIG. 36 Sanitary Cross With Two 45° Side Openings on Same Side (Regular and New Orleans Special) (corresponds to Table 56 of CISPI Specification 301)

ASTM A 888 – 98^{e1}

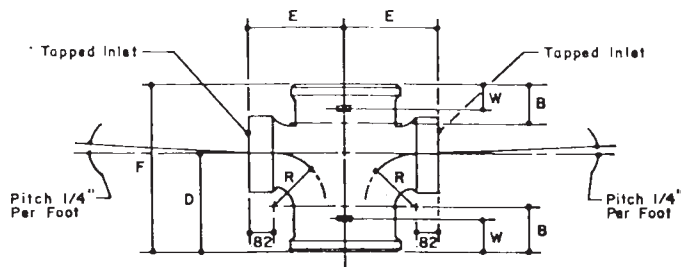

ASA Code Group 022		Dimensions, in. (mm) ^A							
Item No.	√	Size, in.	B	E	F ^B ± 1/8 (3.2)	D	R	IPS Tapping ^C	W
2012	7	1½ by 1½	1½ (38)	2 ⁹ / ₁₆ (65)	5 ¹¹ / ₁₆ (144)	¾ (83)	¾ (44)	1½ (38)	1/8 (29)
2014	3	2 by 1¼	1½ (38)	2 ¹³ / ₁₆ (71)	5 ¹¹ / ₁₆ (144)	¾ (83)	¾ (44)	1¼ (32)	1/8 (29)
2016	8	2 by 1½	1½ (38)	2 ¹³ / ₁₆ (71)	5 ¹¹ / ₁₆ (144)	¾ (83)	¾ (44)	1½ (38)	1/8 (29)
2018	4	2 by 2	1½ (38)	3 ¹ / ₁₆ (78)	6 ³ / ₈ (162)	¾ (95)	2/4 (57)	2 (51)	1/8 (29)
2020	0	3 by 1¼	1½ (38)	3 ⁹ / ₁₆ (84)	5 ¹¹ / ₁₆ (144)	¾ (83)	¾ (44)	1¼ (32)	1/8 (29)
2022	6	3 by 1½	1½ (38)	3 ⁵ / ₁₆ (84)	5 ¹¹ / ₁₆ (144)	¾ (83)	¾ (44)	1½ (38)	1/8 (29)
2024	2	3 by 2	1½ (38)	3 ⁹ / ₁₆ (90)	6 ³ / ₈ (162)	¾ (95)	2/4 (57)	2 (51)	1/8 (29)
2026	7	4 by 1¼	1½ (38)	3 ¹³ / ₁₆ (97)	5 ¹¹ / ₁₆ (144)	¾ (83)	¾ (44)	1¼ (32)	1/8 (29)
2028	3	4 by 1½	1½ (38)	3 ¹³ / ₁₆ (97)	5 ¹¹ / ₁₆ (144)	¾ (83)	¾ (44)	1½ (38)	1/8 (29)
2030	9	4 by 2	1½ (38)	4 ¹ / ₁₆ (103)	5 ⁷ / ₈ (149)	¾ (95)	2/4 (57)	2 (51)	1/8 (29)
2034	1	6 by 1½	2 (51)	4 ³ / ₁₆ (122)	6 ¹¹ / ₁₆ (170)	¾ (95)	¾ (44)	1½ (38)	1/8 (29)
2036	6	6 by 2	2 (51)	5 ¹ / ₁₆ (129)	7 ⁷ / ₁₆ (189)	4/4 (108)	2/4 (57)	2 (51)	1/8 (29)

^A For details of barrel, spigot, and gasket positioning lug, see Fig. 1 and Fig. 2.

^B Dimension F is laying length.

^C For details of tapping bosses, see Fig. 62.

FIG. 37 Sanitary Cross, Tapped (corresponds to Table 57 of CISPI Specification 301)

ASTM A 888 – 98^{e1}

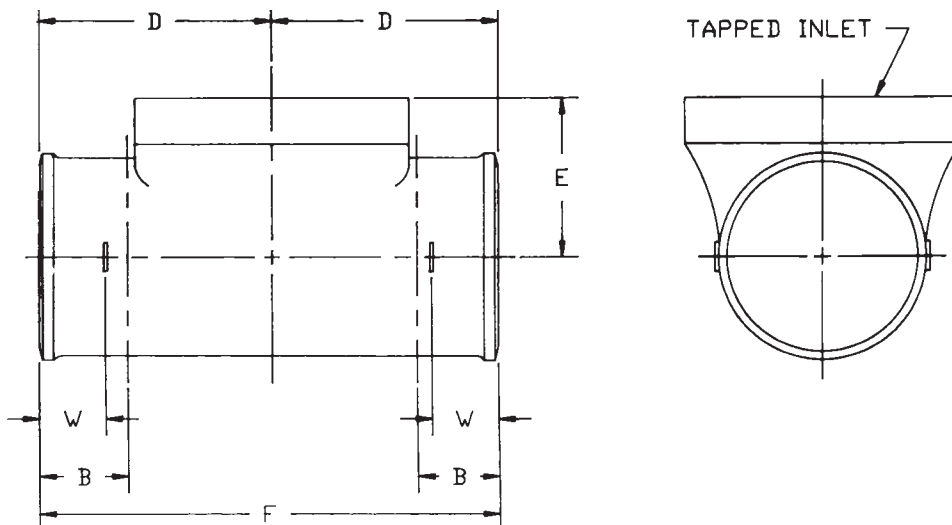

ASA Code Group 022		Size, in.	Dimensions, in. (mm) ^A					
Item No.	✓		B	E	F ^B ± 1/8 (3.2)	D	IPS Tapping ^C	W
2046	5	2	1½ (38)	2 (51)	6¾ (162)	3¾ ₁₆ (81)	2 (51)	1½ (29)
2048	1	3	1½ (38)	2½ ₁₆ (68)	7¾ (197)	3¾ ₈ (98)	3 (76)	1½ (29)
8278	8	4	1½ (38)	3 (76)	8¾ (225)	4¾ ₁₆ (113)	3½ (89)	1½ (29)
2050	7	4	1½ (38)	3 (76)	8¾ (225)	4¾ ₁₆ (113)	4 (102)	1½ (29)
2052	3	5	2 (51)	4½ (114)	11½ (292)	5¾ ₄ (146)	5 (127)	1½ (38)
2054	9	6	2 (51)	5 (127)	12½ (318)	6¼ (159)	6 (152)	1½ (38)
2056	4	8	2 (51)	6 (152)	15¼ (387)	7¾ ₈ (194)	8 (203)	2 (51)
2058	0	10	4 (102)	6½ (165)	20 (508)	10 (254)	10 (254)	2 (51)

^A For details of barrel, spigot, and gasket positioning lug, see Fig. 1 and Fig. 2.

^B Dimension F is laying length.

^C For details of tapping bosses, see Fig. 62.

FIG. 38 Test Tee (corresponds to Table 58 of CISPI Specification 301)

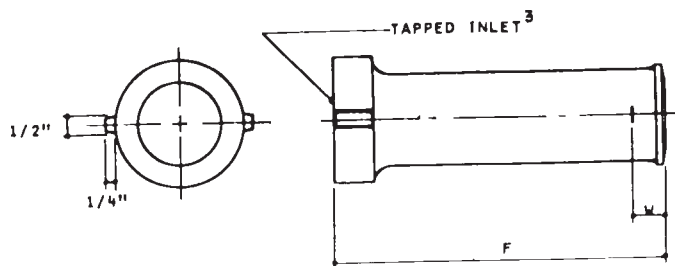

ASA Code Group 022		Size, in.	Dimensions, in. (mm) ^A		
Item No.	✓		F ^B ± 1/8 (3.2)	IPS ^C Tapping ✓	W
2100	0	3	12 (305)	3 (76)	1½ (29)

^A For details of barrel, spigot, and gasket positioning lug, see Fig. 1 and Fig. 2.

^B Dimension F is laying length.

^C For details of tapping bosses, see Fig. 62.

FIG. 39 Tapped Extension Piece (corresponds to Table 62 of CISPI Specification 301)

ASTM A 888 – 98^{e1}

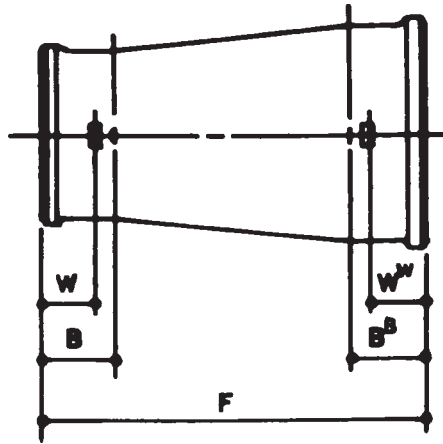

ASA Code Group 022		Size, in.	Dimensions, in. (mm) ^A				
Item No.	✓		B	B ^B	F ^B ± 1/8(3.2)	W	W ^W
2124	0	2 by 3	1½ (38)	1½ (38)	8 (203)	1½ (29)	1½ (29)
2126	5	2 by 4	1½ (38)	1½ (38)	8 (203)	1½ (29)	1½ (29)
2128	1	3 by 4	1½ (38)	1½ (38)	8 (203)	1½ (29)	1½ (29)

^A For details of barrel, spigot, and gasket positioning lug, see Fig. 1 and Fig. 2.

^B Dimension F is laying length.

FIG. 40 Increaser-Reducer (corresponds to Table 63 of CISPI Specification 301)

ASTM A 888 – 98^{e1}

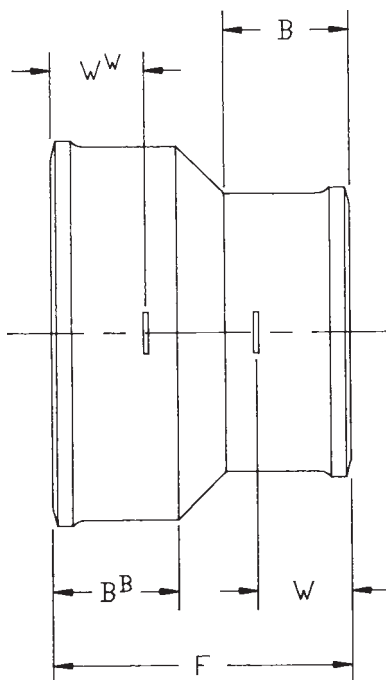

ASA Code Group 022		Size, in.	Dimensions, in. (mm) ^A				
Item No.	✓		B, Minimum	B ^B , Minimum	F ^B ± 1/8 (3.2)	W	W ^W
2138	0	2 by 1½	1½ (38)	1½ (38)	3⅝ (92)	1⅞ (29)	1⅞ (29)
2140	6	3 by 2	1½ (38)	1½ (38)	3⅝ (92)	1⅞ (29)	1⅞ (29)
2142	2	4 by 2	1½ (38)	1½ (38)	3⅝ (92)	1⅞ (29)	1⅞ (29)
2144	8	4 by 3	1½ (38)	1½ (38)	3⅝ (92)	1⅞ (29)	1⅞ (29)
2146	3	5 by 2	1½ (38)	2 (51)	4 (102)	1⅞ (29)	1½ (38)
2148	9	5 by 3	1½ (38)	2 (51)	4 (102)	1⅞ (29)	1½ (38)
2150	5	5 by 4	1½ (38)	2 (51)	4 (102)	1⅞ (29)	1½ (38)
2152	1	6 by 2	1½ (38)	2 (51)	4 (102)	1⅞ (29)	1½ (38)
2154	7	6 by 3	1½ (38)	2 (51)	4 (102)	1⅞ (29)	1½ (38)
2156	2	6 by 4	1½ (38)	2 (51)	4 (102)	1⅞ (29)	1½ (38)
2158	8	6 by 5	2 (51)	2 (51)	4½ (114)	1½ (38)	1½ (38)
2160	4	8 by 2	1½ (38)	2 (51)	4½ (114)	1⅞ (29)	2 (51)
2162	0	8 by 3	1½ (38)	2 (51)	4½ (114)	1⅞ (29)	2 (51)
2164	6	8 by 4	1½ (38)	2 (51)	4½ (114)	1⅞ (29)	2 (51)
2166	1	8 by 5	2 (51)	2 (51)	5 (127)	1½ (38)	2 (51)
2168	7	8 by 6	2 (51)	2 (51)	5 (127)	1½ (38)	2 (51)
2172	9	10 by 4	1½ (38)	3 (76)	5½ (140)	1⅞ (29)	2 (51)
2174	5	10 by 6	2 (51)	3 (76)	6 (152)	1½ (38)	2 (51)
2175	2	10 by 8	2 (51)	3 (76)	6 (152)	2 (51)	2 (51)
2176	0	12 by 4	1½ (38)	3¼ (83)	6½ (165)	1⅞ (29)	2¾ (70)
2177	3	12 by 6	2 (51)	3¼ (83)	6½ (165)	1½ (38)	2¾ (70)
2178	9	12 by 8	2½ (64)	3¼ (83)	7 (178)	2 (51)	2¾ (70)
2179	6	12 by 10	3 (76)	3¼ (83)	7½ (191)	2 (51)	2¾ (70)
2180	8	15 by 4	1½ (38)	3¼ (83)	7 (178)	1⅞ (29)	2¾ (70)
2181	4	15 by 6	2 (51)	3¼ (83)	7 (178)	1½ (38)	2¾ (70)
2182	7	15 by 8	2½ (64)	3¼ (83)	7 (178)	2 (51)	2¾ (70)
2183	1	15 by 10	3 (76)	3¼ (83)	7½ (191)	2 (51)	2¾ (70)
2184	2	15 by 12	3¼ (83)	3¼ (83)	7¾ (197)	2¾ (70)	2¾ (70)

^A For details of barrel, spigot, and gasket positioning lug, see Fig. 1 and Fig. 2.

^B Dimension F is laying length.

FIG. 41 Short, Increaser-Reducer (corresponds to Table 64 of CISPI Specification 301)

ASTM A 888 – 98^{e1}

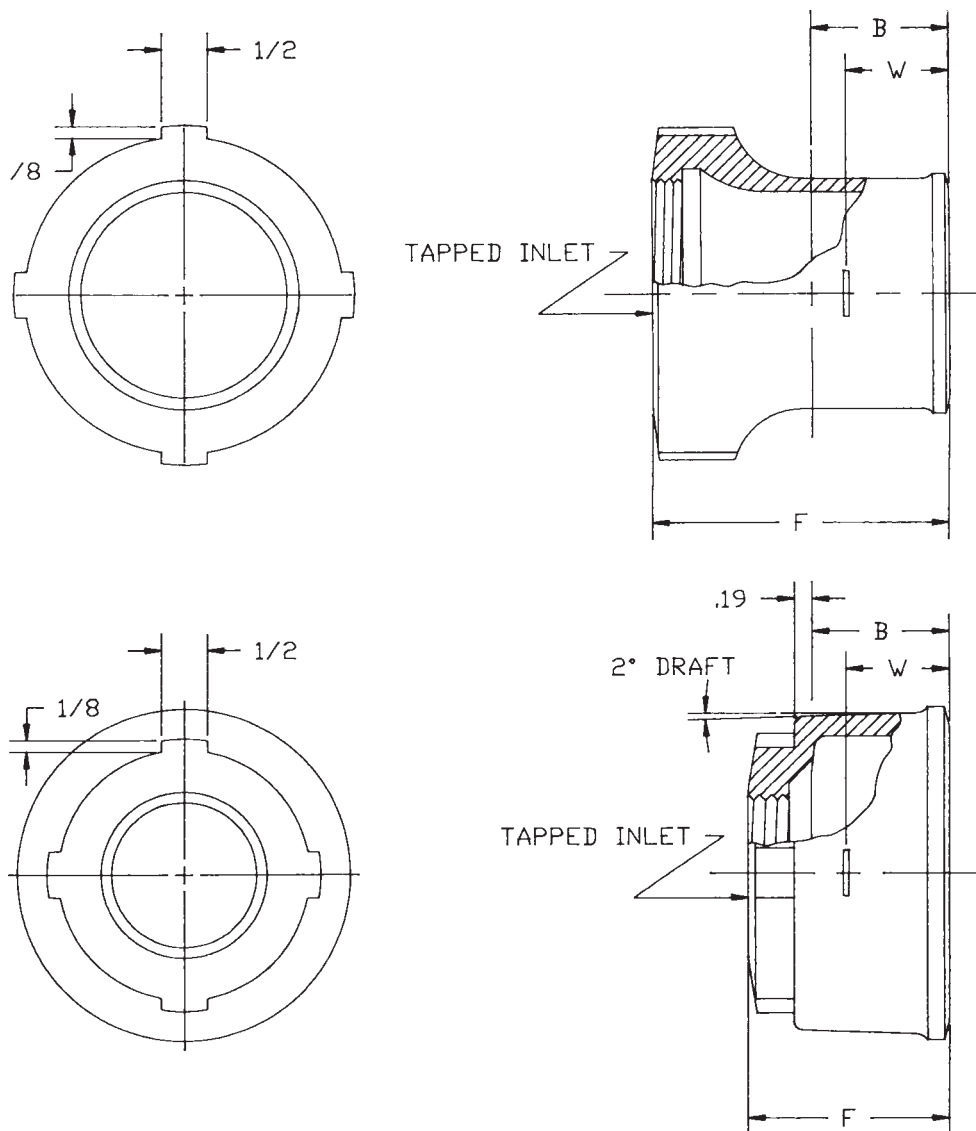

ASA Code Group 022		Size, in.	Dimensions, in. (mm) ^A				
Item No.	√		B	F	IPS Tapping ^B	W ^C	
2236	2	1½ by 1¼	1½ (38)	2⅝ (67)	1¼ (32)	1⅝ (29)	
2238	8	1½ by 1½	1½ (38)	2⅝ (67)	1½ (38)	1⅝ (29)	
2240	4	2 by 1¼	1½ (38)	2⅜ (56)	1¼ (32)	1⅝ (29)	
2242	0	2 by 1½	1½ (38)	2⅜ (56)	1½ (38)	1⅝ (29)	
2244	6	2 by 2	1½ (38)	2⅝ (67)	2 (51)	1⅝ (29)	
2246	1	3 by 1¼	1½ (38)	2⅜ (56)	1¼ (32)	1⅝ (29)	
2248	7	3 by 1½	1½ (38)	2⅜ (56)	1½ (38)	1⅝ (29)	
2250	3	3 by 2	1½ (38)	2⅜ (56)	2 (51)	1⅝ (29)	
2252	9	3 by 2½	1½ (38)	2⅜ (56)	2½ (64)	1⅝ (29)	
2254	5	4 by 3½	1½ (38)	2⅜ (56)	3½ (89)	1⅝ (29)	
2259	4	5 by 4	2 (51)	4½ (114)	4 (102)	1½ (38)	
2262	8	6 by 5	2 (51)	4½ (114)	5 (127)	1½ (38)	
2274	3	8 by 6	2 (51)	4½ (114)	6 (152)	2 (51)	

^A For details of barrel, spigot, and gasket positioning lug, see Fig. 1 and Fig. 2.

^B For details of tapping bosses, see Fig. 62.

^C Inclusion of spigot bead and positioning lug optional with manufacturer based on casting method used.

FIG. 42 Tapped Adapters (corresponds to Table 65 of CISPI Specification 301)

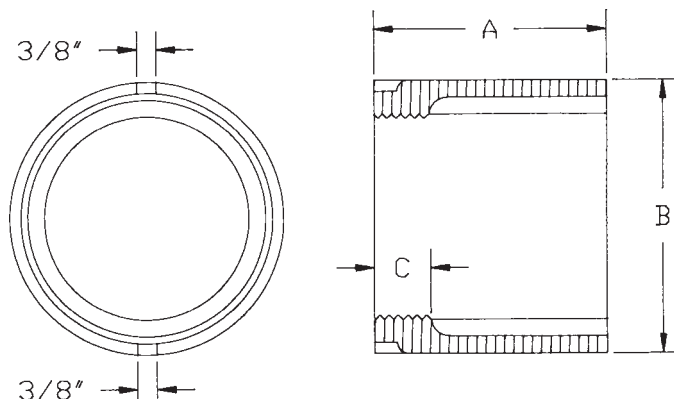
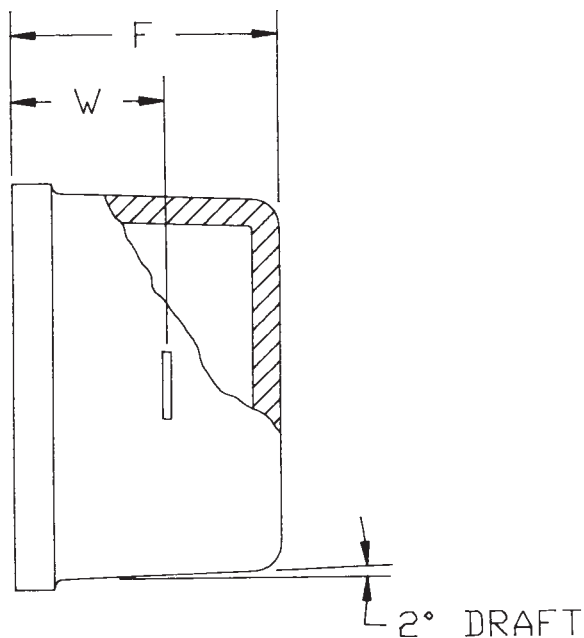

NOTE 1—Inclusion of spigot bead positioning lug optional with manufacturer based on casting method used.

ASA Code Group 022		Size, in.	Dimensions, in. (mm) ^A			
Item No.	✓		A	B	C	IPS Tapping ^B
8564	1	3	2 ³ / ₁₆ (56)	3 ³ / ₈ (86)	3/4 (19)	2 ¹ / ₂ (64)
8566	6	4	2 ³ / ₁₆ (56)	4 ⁷ / ₁₆ (113)	3/4 (19)	3 ¹ / ₂ (89)
8568	2	5	4 ¹ / ₂ (114)	5 ⁵ / ₁₆ (135)	1 (25)	4 (102)
8570	8	6	4 ¹ / ₂ (114)	6 ⁵ / ₁₆ (160)	1 (25)	5 (127)
8572	4	8	...	8 ³ / ₈ (213)	...	6 (152)

^A For details of barrel and spigot, see Fig. 1 and Fig. 2.

^B For details of tapping bosses, see Fig. 62.

FIG. 44 Iron Body Cleanout-Tapped (corresponds to Table 67 of CISPI Specification 301)

ASA Code Group 022		Size, in.	Dimensions, in. (mm) ^A	
Item No.	✓		F ^B ± 1/8 (3.2)	W ^C
2480	6	1 ¹ / ₂	1 ³ / ₄ (44)	1 ¹ / ₈ (29)
2482	2	2	1 ³ / ₄ (44)	1 ¹ / ₈ (29)
2484	8	3	1 ³ / ₄ (44)	1 ¹ / ₈ (29)
2486	3	4	1 ³ / ₄ (44)	1 ¹ / ₈ (29)
2488	9	5	1 ³ / ₄ (44)	1 ¹ / ₂ (38)
2490	5	6	1 ³ / ₄ (44)	1 ¹ / ₂ (38)
2492	1	8	2 ¹ / ₄ (57)	2 (51)
2494	7	10	3 (76)	2 (51)
2495	7	12	3 ¹ / ₂ (89)	2 ³ / ₄ (70)
2496	7	15	3 ¹ / ₂ (89)	2 ³ / ₄ (70)

^A For details of barrel and spigot, see Fig. 1 and Fig. 2.

^B Dimension F is laying length.

^C Inclusion of spigot bead and positioning lug optional with manufacturer based on casting method used.

FIG. 43 Blind Plug (corresponds to Table 66 of CISPI Specification 301)

ASTM A 888 – 98^{e1}

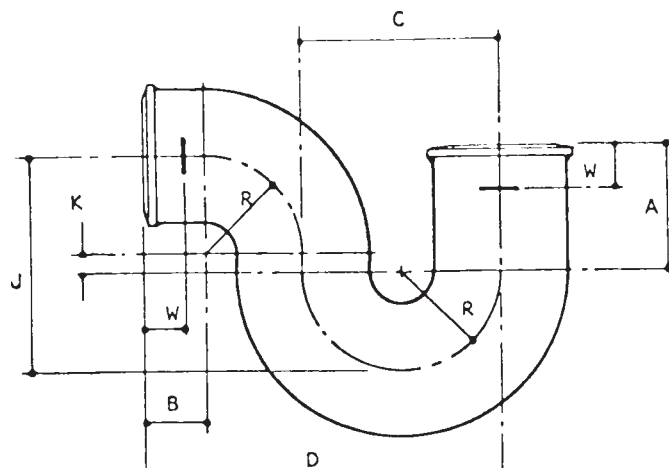

NOTE 1—A minimum water seal of 2 in. (51 mm) is provided for 2-in. size and smaller, 2½ in. (64 mm) for sizes 3 to 6 in. inclusive.

ASA Code Group 022		Size, in.	Dimensions, in. (mm) ^A							
Item No.	✓		A	B	C	D ^B ± 1/8 (3.2)	J	K	R	W
2506	8	1½	2 (51)	1½ (38)	3½ (89)	6¾ (171)	3½ (89)	...	1¾ (44)	1⅝ (29)
2508	4	2	2 (51)	1½ (38)	4 (102)	7½ (191)	4 (102)	...	2 (51)	1⅝ (29)
2510	0	3	3¼ (83)	1½ (38)	5 (127)	9 (229)	5½ (140)	½ (13)	2½ (64)	1⅝ (29)
2512	6	4	4 (102)	1½ (38)	6 (152)	10½ (267)	6½ (165)	½ (13)	3 (76)	1⅝ (29)
2514	2	6	6 (152)	2 (51)	8 (203)	14 (356)	8½ (216)	½ (13)	4 (102)	1½ (38)

^A For details of barrel, spigot, and gasket positioning lug, see Fig. 1 and Fig. 2.

^B Dimension D is laying length.

FIG. 45 P Trap (corresponds to Table 68 of CISPI Specification 301)

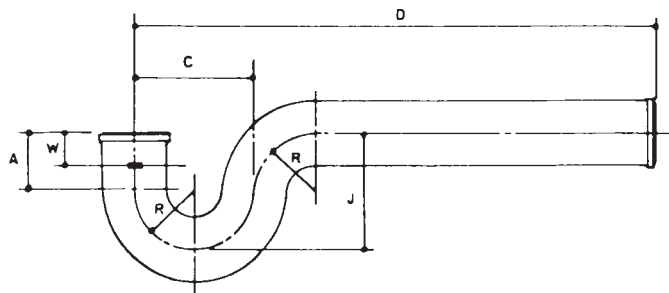

NOTE 1—A minimum water seal of 2 in. (51 mm) is provided for 2-in. size and smaller

ASA Code Group 022		Size, in.	Dimensions, in. (mm) ^A					
Item No.	✓		A	C	D ^B ± 1/8 (3.2)	J	R	W
2527	4	2 by 12	2 (51)	4 (102)	12 (305)	4 (102)	2 (51)	1⅝ (29)
2528	2	2 by 14	2 (51)	4 (102)	14 (356)	4 (102)	2 (51)	1⅝ (29)
2529	0	2 by 16	2 (51)	4 (102)	16 (406)	4 (102)	2 (51)	1⅝ (29)
2530	8	2 by 18	2 (51)	4 (102)	18 (457)	4 (102)	2 (51)	1⅝ (29)
2533	2	2 by 24	2 (51)	4 (102)	24 (610)	4 (102)	2 (51)	1⅝ (29)

^A For details of barrel, spigot, and gasket positioning lug, see Fig. 1 and Fig. 2.

^B Dimension D is laying length.

FIG. 46 Long P Trap (corresponds to Table 69 of CISPI Specification 301)

ASTM A 888 – 98^{e1}

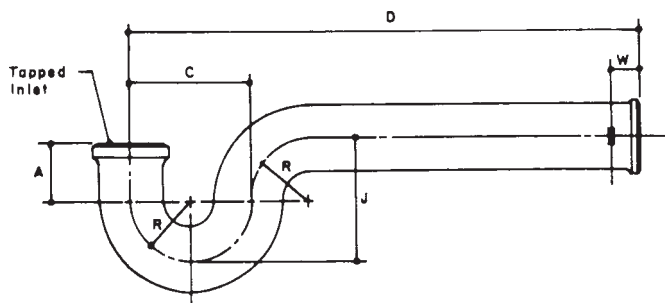

NOTE 1—A minimum water seal of 2 in. (51 mm) is provided for 2-in. size and smaller.

ASA Code Group 022		Size, in.	Dimensions, in. (mm) ^A						
Item No.	✓		A	C	D ^B ± 1/8 (3.2)	J	IPS Tapping ^C	R	W
2535	7	2 by 1½ by 12	2 (51)	4 (102)	12 (305)	4 (102)	1½ (38)	2 (51)	1⅞ (29)
2536	5	2 by 2 by 12	2 (51)	4 (102)	12 (305)	4 (102)	2 (51)	2 (51)	1⅞ (29)
2538	1	2 by 1½ by 14	2 (51)	4 (102)	14 (356)	4 (102)	1½(38)	2 (51)	1⅞ (29)
2539	9	2 by 2 by 14	2 (51)	4 (102)	14 (356)	4 (102)	2 (51)	2 (51)	1⅞ (29)
2541	5	2 by 1½ by 16	2 (51)	4 (102)	16 (406)	4 (102)	1½(38)	2 (51)	1⅞ (29)
2542	3	2 by 2 by 16	2 (51)	4 (102)	16 (406)	4 (102)	2 (51)	2 (51)	1⅞ (29)
2544	9	2 by 1½ by 18	2 (51)	4 (102)	18 (457)	4 (102)	1½(38)	2 (51)	1⅞ (29)
2546	4	2 by 2 by 18	2 (51)	4 (102)	18 (457)	4 (102)	2 (51)	2 (51)	1⅞ (29)

^A For details of barrel, spigot, and gasket positioning lug, see Fig. 1 and Fig. 2.

^B Dimension D is laying length.

^C For details of tapping bosses, see Fig. 62.

FIG. 47 Long P Trap, Tapped (corresponds to Table 70 of CISPI Specification 301)

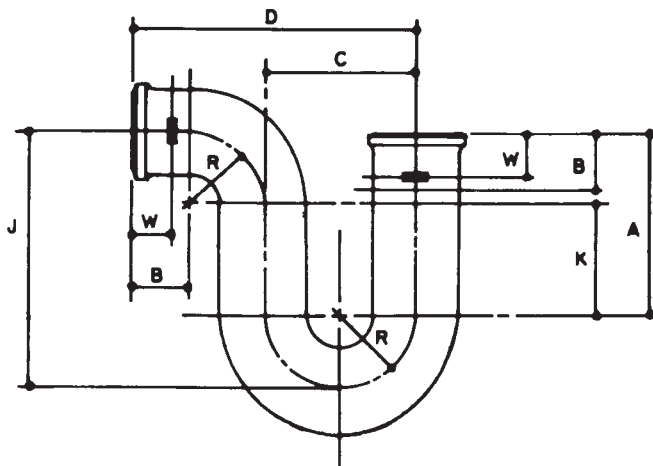

ASA Code Group 022		Size, in.	Dimensions, in. (mm) ^A								
Item No.	✓		A	B	C	D ^B ± 1/8 (3.2)	K	J	R	W	Seal
2564	7	2	5 (127)	1½ (38)	4 (102)	7½ (191)	3 (76)	7 (178)	2 (51)	1⅞ (29)	5 (127)
2566	2	3	4½ (114)	1½ (38)	5 (127)	9 (229)	2 (51)	7 (178)	2½ (64)	1⅞ (29)	4 (102)
2567	0	4	5 (127)	1½ (38)	6 (152)	10½ (267)	2 (51)	8 (203)	3 (76)	1⅞ (29)	4 (102)

^A For detail of barrel, spigot, and gasket positioning lug, see Fig. 1 and Fig. 2.

^B Dimension D is laying length.

FIG. 48 Deep Seal P Trap (corresponds to Table 71 of CISPI Specification 301)

ASTM A 888 – 98^{e1}

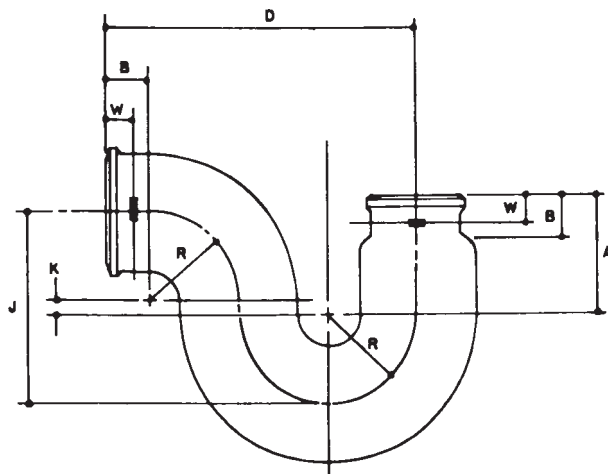

NOTE 1—A minimum water seal of 2½ in. (64 mm) is provided for sizes 3 and 4 in.

ASA Code Group 022		Size, in.	Dimensions, in. (mm) ^A							
Item No.	✓		A	B	C	J	K	D ^B ± 1/8 (3.2)	R	W
8548	4	3 by 2	3¼ (83)	1½ (38)	5 (127)	5½ (140)	½ (13)	9 (229)	2½ (64)	1⅞ (29)
8550	0	4 by 3	4 (102)	1½ (38)	6 (152)	6½ (165)	½ (13)	10½ (267)	3 (76)	1⅞ (29)

^A For details of barrel, spigot, and gasket positioning lug, see Fig. 1 and Fig. 2.

^B Dimension D is laying length.

FIG. 49 P Trap, Reducing (corresponds to Table 72 of CISPI Specification 301)

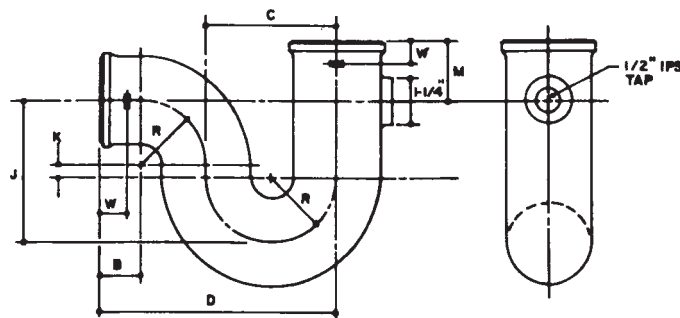

NOTE 1—A minimum water seal of 2 in. (51 mm) is provided for 2-in. size and smaller, 2½ in. (64 mm) for sizes 3 to 4 in. inclusive.

ASA Code Group 022		Size, in.	Dimensions, in. (mm) ^A									
Item No.	✓		A	B	C	D ^B ± 1/8 (3.2)	J	K	R	W	M	IPS Tapping ^C
8530	2	2	2 (51)	1½ (38)	4 (102)	7½ (191)	4 (102)	0 (0)	2 (51)	1⅞ (29)	2 (51)	½ (13)
8532	8	3	3¼ (83)	1½ (38)	5 (127)	9 (229)	5½ (140)	½ (13)	2½ (64)	1⅞ (29)	2 (51)	½ (13)
8534	4	4	4 (102)	1½ (38)	6 (152)	10½ (267)	6½ (165)	½ (13)	3 (76)	1⅞ (29)	2 (51)	½ (13)

^A For details of barrel, spigot, and gasket positioning lug, see Fig. 1 and Fig. 2.

^B Dimension D is laying length.

^C Minimum thickness of threaded section of primer tap is 0.21 in. (5.3 mm).

FIG. 50 P Trap with Primer (corresponds to Table 73 of CISPI Specification 301)

ASTM A 888 – 98^{e1}

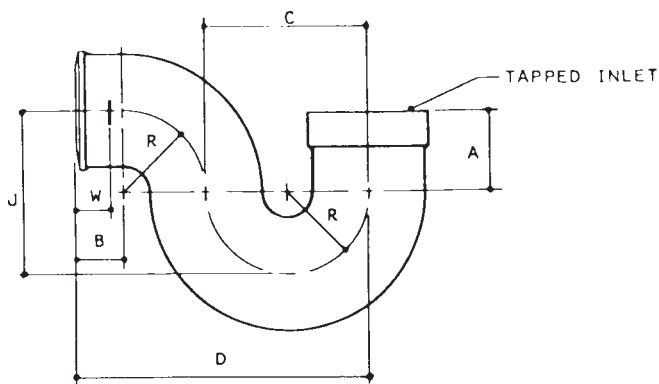

NOTE 1—A minimum water seal of 2 in. (51 mm) is provided for 2-in. size and smaller.

ASA Code Group 022		Size, in.	Dimensions, in. (mm) ^A							
Item No.	√		A	B	C	D ^B ± 1/8 (3.2)	J	R	IPS Tapping ^C	W
2580	3	1½ by 1¼	2 (51)	1½ (38)	3½ (89)	6¾ (171)	3½ (89)	1¾ (44)	1¼ (32)	1⅛ (29)
2582	9	1½ by 1½	2 (51)	1½ (38)	3½ (89)	6¾ (171)	3½ (89)	1¾ (44)	1½ (38)	1⅛ (29)
2584	5	2 by 1¼	2 (51)	1½ (38)	4 (102)	7½ (191)	4 (102)	2 (51)	1¼ (32)	1⅛ (29)
2586	0	2 by 1½	2 (51)	1½ (38)	4 (102)	7½ (191)	4 (102)	2 (51)	1½ (38)	1⅛ (29)
2588	6	2 by 2	2 (51)	1½ (38)	4 (102)	7½ (191)	4 (102)	2 (51)	2 (51)	1⅛ (29)

^A For details of barrel, spigot, and gasket positioning lug, see Fig. 1 and Fig. 2.

^B Dimension D is laying length.

^C For details of tapping bosses, see Fig. 62.

FIG. 51 P Trap With Tapped Inlet (corresponds to Table 74 of CISPI Specification 301)

ASTM A 888 – 98^{e1}

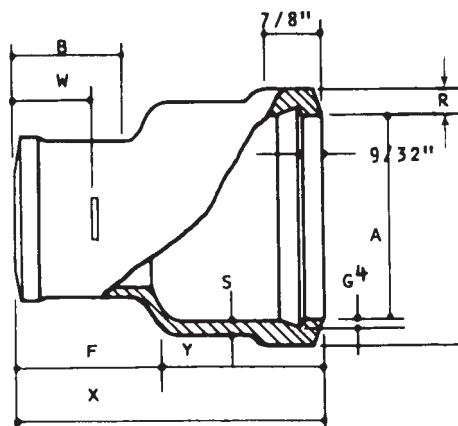

NOTE 1—Dimension G maximum 0.13, minimum 0.10.

ASA Code Group 022		Dimensions, in. (mm) ^A						
Item No.	✓	Size, in.	A			B	X ± 1/8 (3.2)	R
			SV	XH	Tolerance			
2222	2	2	2.94 (74.7)	3.06 (77.7)	±0.06 (±1.52)	1 1/2 (38)	4 1/2 (114)	0.34 (8.64)
2224	8	3	3.94 (100.1)	4.19 (106.4)	-0.06 + 0.09 (-1.52 + 2.29)	1 1/2 (38)	4 3/4 (121)	0.37 (9.40)
2226	3	4	4.94 (125.5)	5.19 (131.8)	-0.06 + 0.09 (-1.52 + 2.29)	1 1/2 (38)	5 1/4 (133)	0.37 (9.40)

Size, in.	Dimensions, in. (mm) ^A			
	S	W ^B	F ^C ± 1/8 (3.2)	Y ^D ± 1/16 (1.6)
2	0.13 (3.30)	1 1/8 (29)	2 (51)	2 1/2 (64)
3	0.16 (4.06)	1 1/8 (29)	2 (51)	2 3/4 (70)
4	0.16 (4.06)	1 1/8 (29)	2 1/4 (57)	3 (76)

^A For details of barrel and spigot, see Fig. 1 and Fig. 2.

^B Inclusion of spigot bead and positioning lug optional with manufacturer based on casting method used.

^C Dimension F is laying length.

^D Dimension Y is telescoping length.

FIG. 52 Hub Adapter (corresponds to Table 75 of CISPI Specification 301)

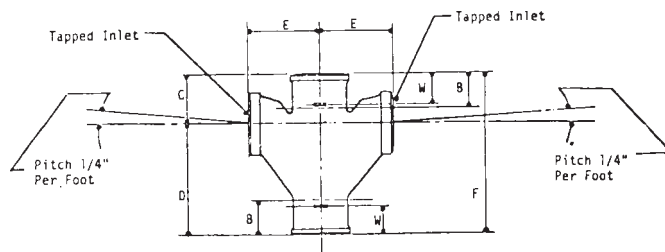

ASA Code Group 022		Size, in.	Dimensions, in. (mm) ^A						
Item No.	✓		B	C	D	F ^B ± 1/8 (3.2)	E	IPS Tapping ^C	W
8002	2	2 by 2 by 1 1/2 by 1 1/2	1 1/2 (38)	2 1/8 (54)	4 7/8 (124)	7 (178)	3 3/16 (81)	1 1/2 (38)	1 1/8 (29)

^A For details of barrel, spigot, and gasket positioning lug, see Fig. 1 and Fig. 2.

^B Dimension F is laying length.

^C For details of tapping bosses, see Fig. 62.

FIG. 53 Tapped Inlet, Double (corresponds to Table 76, Fig. 1A of CISPI Specification 301)

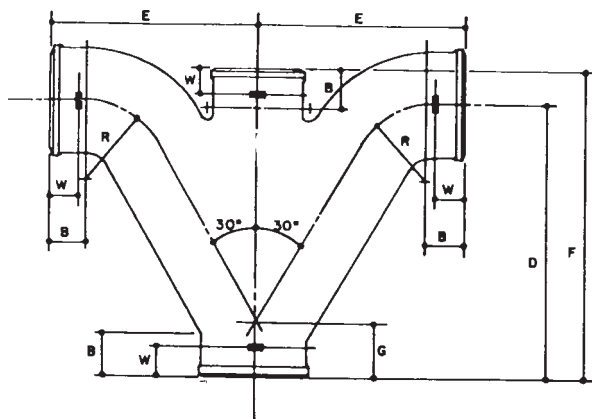

ASA Code Group 022			Dimensions, in. (mm) ^A						
Item No.	√	Size, in.	B	D	$E^B \pm \frac{1}{8}$ (3.2)	$F^B \pm \frac{1}{8}$ (3.2)	G	R	W
8052	7	2	1½ (38)	6½ (165)	5 (127)	8 (203)	1⅜ (46)	1⅜ (35)	1⅝ (29)
8054	3	3 by 2 by 3	1½ (38)	8⅞ (225)	6⅞ (167)	9¼ (235)	2 (51)	2½ (64)	1⅝ (29)
8056	8	3	1½ (38)	8⅞ (225)	6⅞ (167)	10⅞ (257)	2 (51)	2½ (64)	1⅝ (29)
8058	4	4 by 2 by 4	1½ (38)	10¼ (260)	7¾ (197)	11½ (292)	1⅝ (49)	3 (76)	1⅝ (29)
8060	0	4 by 3 by 4	1½ (38)	10¼ (260)	7¾ (197)	11½ (292)	2⅛ (52)	3 (76)	1⅝ (29)
8062	6	4	1½ (38)	10¼ (260)	7¾ (197)	12 (305)	1⅝ (49)	3 (76)	1⅝ (29)

^A For details of barrel, spigot, and gasket positioning lug, see Fig. 1 and Fig. 2.

^B Dimensions E and F are laying lengths.

FIG. 54 Modified Combination Wye and 1/8 Bend, Double (corresponds to Table 80, Fig. 5 of CISPI Specification 301)

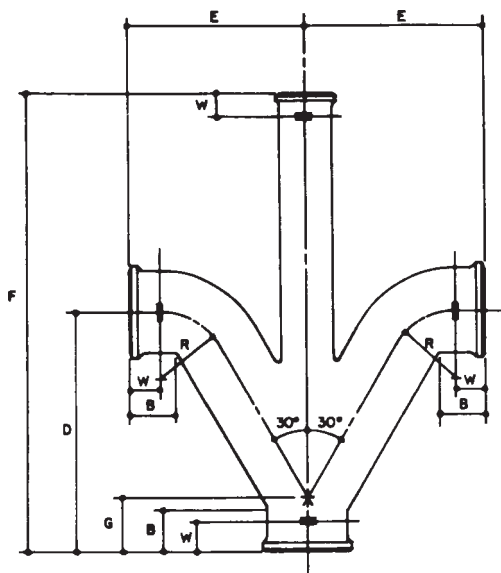

ASA Code Group 022			Dimensions, in. (mm) ^A						
Item No.	√	Size, in.	$E^B \pm \frac{1}{8}$ (3.2)	B	$F^B \pm \frac{1}{8}$ (3.2)	G	D	R	W
8088	1	3 by 2 by 3	6⅞ (167)	1½ (38)	16⅞ (429)	2 (51)	8⅞ (225)	2½ (64)	1⅝ (29)
090	7	4 by 2 by 4	7⅞ (194)	1½ (38)	18¾ (476)	1⅝ (49)	10¼ (260)	3 (76)	1⅝ (29)

^A For details of barrel, spigot, and gasket positioning lug, see Fig. 1 and Fig. 2.

^B Dimensions E and F are laying lengths.

FIG. 55 Modified Combination Wye and 1/8 Bend, Double, Extended (corresponds to Table 80, Fig. 5, Extended, of CISPI Specification 301)

ASTM A 888 – 98^{e1}

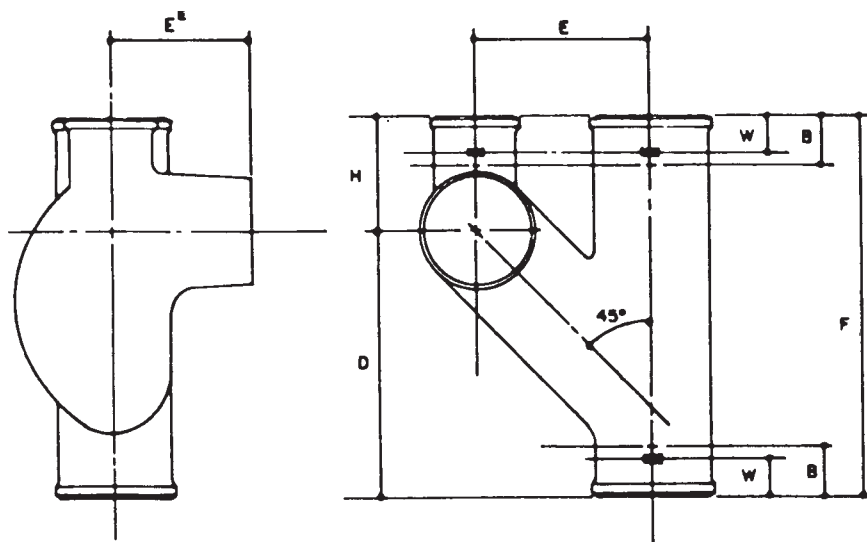

NOTE 1—On side opening, inclusion of spigot bead and positioning lug optional with manufacturer based on casting method used.
 NOTE 2—Positioning lug shall be omitted on 2 in. extensions.
 NOTE 3—Double fittings shall have baffles.

ASA Code Group 022		Dimensions, in. (mm) ^A									
Item No.	✓	Size, in.	E	B	H	H Extended	D	E ^E	F ^B ± 1/8 (3.2)	F Extended ^B ± 1/8 (3.2)	W
Regular											
8100	4	3 by 2 RH	5 1/16 (129)	1 1/2 (38)	3 7/16 (87)	...	7 9/16 (192)	4 1/8 (105)	11 (279)	...	1 1/8 (29)
8102	0	3 by 2 LH	5 1/16 (129)	1 1/2 (38)	3 7/16 (87)	...	7 9/16 (192)	4 1/8 (105)	11 (279)	...	1 1/8 (29)
8108	7	3 by 2 DBL	5 1/16 (129)	1 1/2 (38)	3 7/16 (87)	...	7 9/16 (192)	4 1/8 (105)	11 (279)	...	1 1/8 (29)
8106	1	4 by 2 RH	6 1/2 (165)	1 1/2 (38)	4 (102)	...	9 (229)	4 1/2 (114)	13 (330)	...	1 1/8 (29)
8104	6	4 by 2 LH	6 1/2 (165)	1 1/2 (38)	4 (102)	...	9 (229)	4 1/2 (114)	13 (330)	...	1 1/8 (29)
Extended											
8122	8	3 by 2 RH	5 1/16 (129)	1 1/2 (38)	...	9 7/16 (240)	7 9/16 (192)	4 1/8 (105)	...	17 (432)	1 1/8 (29)
8120	2	3 by 2 LH	5 1/16 (129)	1 1/2 (38)	...	9 7/16 (240)	7 9/16 (192)	4 1/8 (105)	...	17 (432)	1 1/8 (29)
8126	9	4 by 2 RH	6 1/2 (165)	1 1/2 (38)	...	8 (203)	9 (229)	4 1/2 (114)	...	17 (432)	1 1/8 (29)
8124	4	4 by 2 LH	6 1/2 (165)	1 1/2 (38)	...	8 (203)	9 (229)	4 1/2 (114)	...	17 (432)	1 1/8 (29)
8130	1	4 by 2 DBL	6 1/2 (165)	1 1/2 (38)	...	8 (203)	9 (229)	4 1/2 (114)	...	17 (432)	1 1/8 (29)

^A For details of barrel, spigot, and gasket positioning lug, see Fig. 1 and Fig. 2.

^B Dimensions F and F Extended are laying lengths.

FIG. 56 Regular or Extended Left or Right and Regular or Extended Double (corresponds to Table 82, Fig. 6 of CISP1 Specification 301)

ASTM A 888 – 98^{e1}

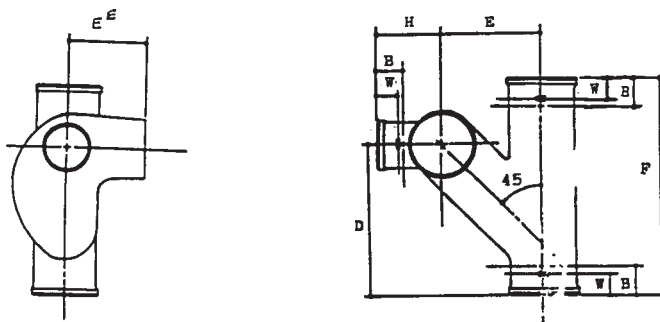

NOTE 1—On side opening, inclusion of spigot bead and positioning lug optional with manufacturer based on casting method used.
 NOTE 2—Positioning lug to be omitted on 2 in. extensions.
 NOTE 3—Double fittings shall have baffles.

ASA Code Group 022		Size, in.	Dimensions, in. (mm) ^A							
Item No.	✓		E	B	H	H Extended	D	E ^E	F ^B ± 1/8 (3.2)	W
Regular										
8136	8	3 by 2 RH	5 1/16 (129)	1 1/2 (38)	3 7/16 (87)	...	7 9/16 (192)	4 1/8 (105)	11 (279)	1 1/8 (29)
8138	4	3 by 2 LH	5 1/16 (129)	1 1/2 (38)	3 7/16 (87)	...	7 9/16 (192)	4 1/8 (105)	11 (279)	1 1/8 (29)
8144	2	3 by 2 DBL	5 1/16 (129)	1 1/2 (38)	3 7/16 (87)	...	7 9/16 (192)	4 1/8 (105)	11 (279)	1 1/8 (29)
8140	0	4 by 2 RH	6 1/2 (165)	1 1/2 (38)	4 (102)	...	9 (229)	4 1/2 (114)	13 (330)	1 1/8 (29)
8142	6	4 by 2 LH	6 1/2 (165)	1 1/2 (38)	4 (102)	...	9 (229)	4 1/2 (114)	13 (330)	1 1/8 (29)
Extended										
8156	6	3 by 2 RH	5 1/16 (129)	1 1/2 (38)	...	9 7/16 (240)	7 9/16 (192)	4 1/8 (105)	11 (279)	1 1/8 (29)
8158	2	3 by 2 LH	5 1/16 (129)	1 1/2 (38)	...	9 7/16 (240)	7 9/16 (192)	4 1/8 (105)	11 (279)	1 1/8 (29)
8160	8	4 by 2 RH	6 1/2 (165)	1 1/2 (38)	...	8 (203)	9 (229)	4 1/2 (114)	13 (330)	1 1/8 (29)
8162	4	4 by 2 LH	6 1/2 (165)	1 1/2 (38)	...	8 (203)	9 (229)	4 1/2 (114)	13 (330)	1 1/8 (29)
8166	5	4 by 2 DBL	6 1/2 (165)	1 1/2 (38)	...	8 (203)	9 (229)	4 1/2 (114)	13 (330)	1 1/8 (29)

^A For details of barrel, spigot, and gasket positioning lug, see Fig. 1 and Fig. 2.

^B Dimensions F and F Extended are laying lengths.

FIG. 57 Regular or Extended Left or Right and Regular or Extended Double (corresponds to Table 83, Fig. 8 of CISPI Specification 301)

ASTM A 888 – 98^{e1}

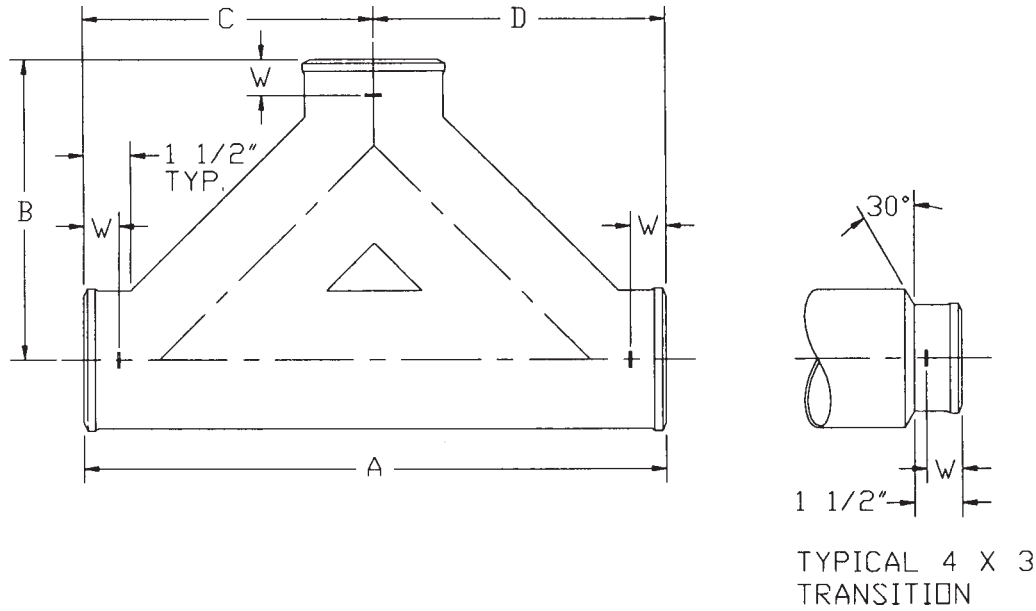

ASA Code Group 022		Size, in.	Dimensions, in. (mm)				
Item No.	✓		A	B	C	D	W
8442	0	3 by 3 by 4	15 (381)	9 (229)	7½ (191)	7½ (91)	1⅞ (29)
8444	6	4 by 3 by 4	19½ (495)	9½ (241)	9⅜ (233)	10¼ (260)	1⅞ (29)
8446	1	4 by 4 by 4	18⅞ (467)	9½ (241)	9⅜ (233)	9⅜ (233)	1⅞ (29)

FIG. 58 Two-Way Cleanout (corresponds to Table 87 of CISPI Specification 301)

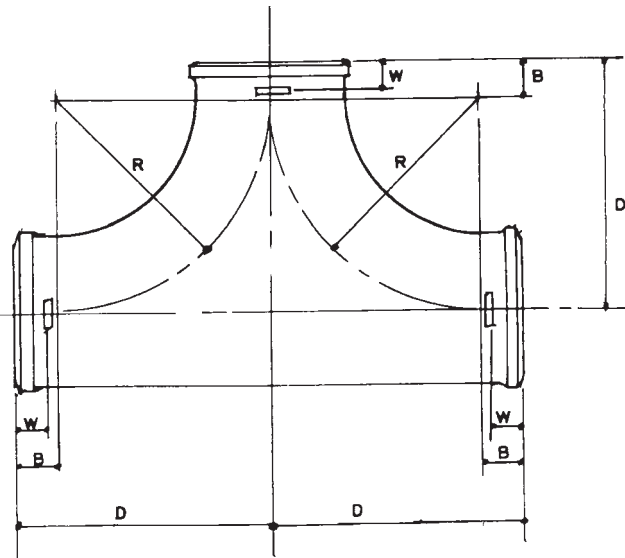

ASA Code Group 022		Size, in.	Dimensions, in. (mm) ^A			
Item No.	✓		D ^B ± 1/8 (3.2)	R	B	W
2990	2	4	7½ (191)	6 (152)	1½ (38)	1⅞ (29)

^A For details of barrel, spigot, and gasket positioning lug, see Fig. 1 and Fig. 2.
^B Dimension D is laying length.

FIG. 59 Twin Cleanout (corresponds to Table 88 of CISPI Specification 301)

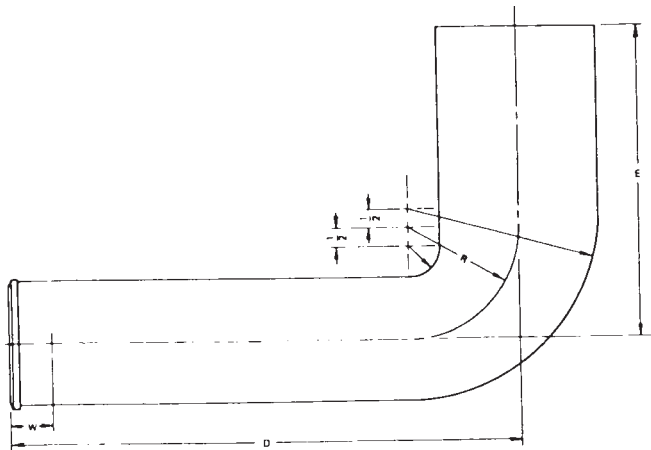

NOTE 1—Inclusion of spigot bead and positioning lug optional with manufacturer, based on casting method used.

NOTE 2—Inclusion of breaking rings on inlet end optional.

Size, in.	Dimensions, in. (mm) ^A			
	D ^B ± 1/8 (3.2)	E ^B ± 1/8 (32)	R	W
3 by 4	Various	Various	3 (76)	1 1/8 (29)
4 by 4	Various	Various	3 (76)	1 1/8 (29)

ASA Code Group 022		Sizes Assigned EDP Numbers	Description
Item No.	✓		
2822	9	3 by 4 by 4 by 16 (76 by 102 by 102 by 406)	reducing closet bend
2832	8	3 by 4 by 6 by 12 (76 by 102 by 152 by 305)	reducing closet bend
2842	7	3 by 4 by 6 by 16 (76 by 102 by 152 by 406)	reducing closet bend
2852	6	3 by 4 by 10 by 12 (76 by 102 by 254 by 305)	reducing closet bend
2862	5	3 by 4 by 10 by 16 (76 by 102 by 254 by 406)	reducing closet bend
2872	4	3 by 4 by 12 by 16 (76 by 102 by 305 by 406)	reducing closet bend
2894	8	4 by 4 by 4 by 16 (102 by 102 by 102 by 406)	closet bend
2904	5	4 by 4 by 6 by 12 (102 by 102 by 152 by 305)	closet bend
2914	4	4 by 4 by 6 by 16 (102 by 102 by 152 by 406)	closet bend
2924	3	4 by 4 by 10 by 12 (102 by 102 by 254 by 305)	closet bend
2934	2	4 by 4 by 10 by 16 (102 by 102 by 254 by 406)	closet bend
2944	1	4 by 4 by 12 by 16 (102 by 102 by 305 by 406)	closet bend

^A For details of barrel, spigot, and gasket positioning lug, see Fig. 1 and Fig. 2.

^B Dimensions D and E are laying lengths.

FIG. 60 Closet Bend (corresponds to Table 89 of CISPI Specification 301)

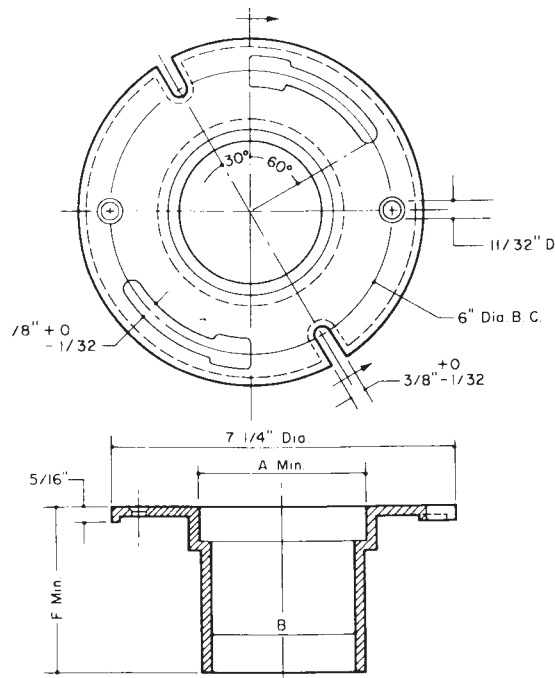

ASA Code Group 022		Size, in.	Dimensions, in. (mm)		
Item No.	✓		A, Minimum	B	F, Minimum
2966	4	4 by 3 by 3 1/2	4 (102)	3 (76)	3 1/2 (89)
2968	0	4 by 3 by 5 1/2	4 (102)	3 (76)	5 1/2 (140)
2970	6	4 by 4 by 4	4 (102)	4 (102)	4 (102)

FIG. 61 Closet Flange Riser (corresponds to Table 90 of CISPI Specification 301)

ASTM A 888 – 98^{e1}

DETAILS OF TAPPING BOSSES

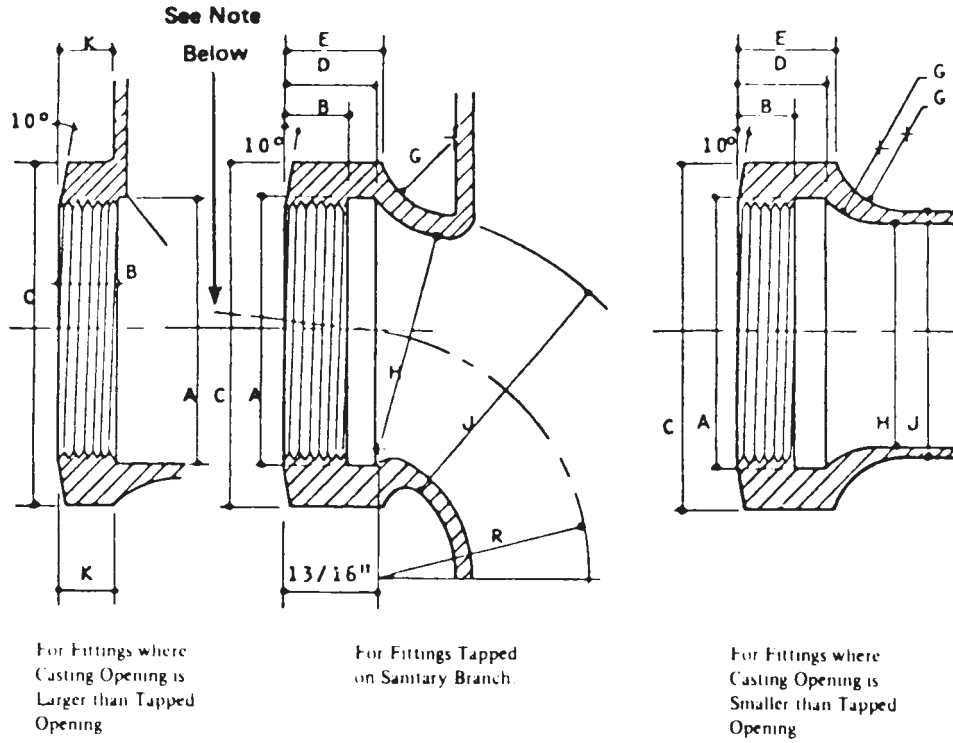

NOTE 1—Horizontal inlet waste bosses to be tapped at an angle of 1/4 in. (6 mm) per foot to provide flow.

Size, in.	Dimensions, in. ^A									
	A	B	C	D	E	G	H	J	K	R
1 1/4	1 15/16	7/16	2 11/16	3/4	7/8	1/2	1 1/2	1 13/16	1/2	1 3/4
1 1/2	1 15/16	7/16	2 11/16	3/4	7/8	1/2	1 1/2	1 13/16	1/2	1 3/4
2	2 7/16	7/16	3 1/4	3/4	1 5/16	5/8	2	2 5/16	1/2	2 1/4
2 1/2	3	9/8	3 9/16	1	1 1/8	3/4	2 1/2	2 13/16	5/8	2 3/4
3	3 9/16	3/4	4 5/8	1 3/16	1 9/16	1	3	3 5/16	3/4	3
3 1/2	4 1/16	3/4	5 1/8	1 1/4	1 3/8	1	3 1/2	3 13/16	3/4	3
4	4 9/16	1 3/16	5 3/4	1 1/4	1 7/16	1 1/8	4	4 1/2	1 3/16	3 1/2
5	5 5/8	1 5/16	7 1/16						1 3/8	
6	6 1 1/16	1	8 5/16						1 7/16	
8	8 7/8	1	10 1/4						1 13/16	
10	11	1 1/4	12						1 15/16	

^A 1 in. = 25.4 mm.

FIG. 62 Dimensions for Tapping Bosses (corresponds to Table 91 of CISPI Specification 301)