



# Standard Specification for Steel Investment Castings General Requirements, for Pressure-Containing Parts<sup>1</sup>

This standard is issued under the fixed designation A 985; the number immediately following the designation indicates the year of original adoption or, in the case of revision, the year of last revision. A number in parentheses indicates the year of last reapproval. A superscript epsilon ( $\epsilon$ ) indicates an editorial change since the last revision or reapproval.

## 1. Scope

1.1 This specification covers a group of common requirements, which are mandatory for steel castings produced by the investment casting process for pressure-containing parts under each of the following ASTM Specifications:

Title of Specification	ASTM Designation
Steel Castings, Carbon, Suitable for Fusion Welding for High-Temperature Service	A 216/A 216M <sup>2</sup>
Steel Castings, Martensitic Stainless and Alloy, for Pressure-Containing Parts Suitable for High-Temperature Service	A 217/A 217M <sup>2</sup>
Castings, Austenitic, Austenitic-Ferritic (Duplex), for Pressure-Containing Parts	A 351/A 351M <sup>2</sup>
Steel Castings, Ferritic and Martensitic, for Pressure-Containing Parts Suitable for Low-Temperature Service	A 352/A 352M <sup>2</sup>
Steel Castings, Alloy, Specially Heat-Treated, for Pressure-Containing Parts, Suitable for High-Temperature Service	A 389/A 389M <sup>2</sup>
Steel Castings Suitable for Pressure Service	A 487/A 487M <sup>2</sup>

1.2 This specification also covers a group of supplementary requirements, which may be applied to the above specifications as indicated therein. These requirements are provided for use when additional testing or inspection is desired and apply only when specified individually by the purchaser in the order.

1.3 When investment casting are ordered, the requirements of this specification shall take precedence over the individual material specification requirements.

1.4 The values stated in either inch-pound or SI units are to be regarded separately as the standard. Within the text, the SI units are shown in parentheses. The values in each system are not exact equivalent; therefore, each system must be used independently of the other. Combining values from the two systems may result in nonconformance with this specification. Inch-pound units are applicable for material ordered to Specification A 985 and SI units for material ordered to Specification A 985M.

1.5 *This standard does not purport to address all of the safety concerns, if any, associated with its use. It is the responsibility of the user of this standard to establish appropriate safety and health practices and determine the applica-*

*bility of regulatory limitations prior to use.*

## 2. Referenced Documents

### 2.1 ASTM Standards:

- A 216/A 216M Specification for Steel Castings, Carbon, Suitable for Fusion Welding for High-Temperature Service<sup>2</sup>
- A 217/A 217M Specification for Steel Castings, Martensitic Stainless and Alloy, for Pressure-Containing Parts Suitable for High-Temperature Service<sup>2</sup>
- A 351/A 351M Specification for Castings, Austenitic, Austenitic-Ferritic (Duplex), for Pressure-Containing Parts<sup>2</sup>
- A 352/A 352M Specification for Steel Castings, Ferritic and Martensitic, for Pressure-Containing Parts Suitable for Low-Temperature Service<sup>2</sup>
- A 370 Test Methods for Definitions for Mechanical Testing of Steel Products
- A 389/A 389M Specification for Steel Castings, Alloy, Specially Heat-Treated, for Pressure-Containing Parts, Suitable for High-Temperature Service<sup>2</sup>
- A 487/A 487M Specification for Steel Castings Suitable for Pressure Service<sup>2</sup>
- A 488/A 488M Practice for Steel Castings, Welding, Qualification of Procedures and Personnel<sup>2</sup>
- A 609/A 609M Practice for Castings, Carbon, Low-Alloy, and Martensitic Stainless Steel, Ultrasonic Examination Thereof<sup>2</sup>
- A 751 Test Methods, Practices, and Terminology for Chemical Analysis of Steel Products<sup>3</sup>
- A 800/A 800M Practice for Steel Castings, Austenitic Alloy, Estimating Ferrite Content Thereof<sup>2</sup>
- A 903/A 903M Specification for Steel Castings, Surface Acceptance Standards, Magnetic Particle and Liquid Penetrant Inspection<sup>2</sup>
- A 919 Terminology Relating to Heat Treatment of Metals<sup>2</sup>
- E 29 Practice for Using Significant Figures in Test Data to Determine Conformance with Specifications<sup>4</sup>
- E 94 Guide for Radiographic Testing<sup>5</sup>
- E 125 Reference Photographs for Magnetic Particle Indications on Ferrous Castings<sup>5</sup>

<sup>1</sup> This practice is under the jurisdiction of ASTM Committee A-01 on Steel, Stainless Steel, and Related Alloys and is the direct responsibility of Subcommittee A01.08 on Castings.

Current edition approved Sept. 10, 1998. Published January 1999.

<sup>2</sup> *Annual Book of ASTM Standards*, Vol 01.02.

<sup>3</sup> *Annual Book of ASTM Standards*, Vol 01.01.

<sup>4</sup> *Annual Book of ASTM Standards*, Vol 14.02.

<sup>5</sup> *Annual Book of ASTM Standards*, Vol 03.03.

- E 165 Test Method for Liquid Penetrant Examination<sup>5</sup>
- E 186 Reference Radiographs for Heavy-Walled (2 to 4½-in. (51 to 114-mm)) Steel Castings<sup>5</sup>
- E 192 Reference Radiographs for Investments<sup>6</sup> Steel Castings of Aerospace Applications<sup>5</sup>
- E 208 Test Method for Conducting Drop-Weight Test to Determine Nil-Ductility Transition Temperature of Ferritic Steels<sup>7</sup>
- E 280 Reference Radiographs for Heavy-Walled (4½ to 12-in. (114 to 305-mm)) Steel Castings<sup>5</sup>
- E 340 Test Method for Macroetching Metals and Alloys<sup>7</sup>
- E 353 Test Methods for Chemical Analysis of Stainless, Heat-Resisting, Maraging, and Other Similar Chromium-Nickel-Iron Alloys<sup>6</sup>
- E 354 Test Methods for Chemical Analysis of High-Temperature, Electrical, Magnetic, and Other Similar Iron, Nickel, and Cobalt Alloys<sup>6</sup>
- E 446 Reference Radiographs for Steel Castings Up to 21 in. (51 mm) in Thickness<sup>5</sup>
- E 709 Guide for Magnetic Particle Examination<sup>5</sup>

### 2.2 ANSI Standard:<sup>8</sup>

B16.5 Steel Pipe Flanges and Flanged Fittings

### 2.3 ASME Standard:<sup>9</sup>

ASME Boiler and Pressure Vessel Code, Section III, NB-2546

### 2.4 Standards of the Manufacturer's Standardization Society of the Valve and Fitting Industry:<sup>10</sup>

MSS SP 53 Quality Standard for Steel Castings for Valves, Flanges and Fittings, and Other Piping Components (Dry Magnetic Particle Inspection Method)

MSS SP 54 Quality Standard for Steel Castings for Valves, Flanges and Fittings, and Other Piping Components (Radiographic Inspection Method)

### 2.5 SAE Aerospace Recommended Practice:<sup>11</sup>

ARP 1341 Determining Decarburization and Carburization in Finished Parts of Carbon and Low-Alloy Steel

## 3. Terminology

3.1 *Definitions*—The definitions in Test Methods and Definitions A 370 and Terminology A 919 are applicable to this specification and those listed in 1.1.

### 3.2 Definitions of Terms Specific to This Standard:

3.2.1 *heat, n*—all the molten metal poured from a single furnace or all of the molten metal from two or more furnaces poured into a single ladle or casting prior to the replenishing of the furnace(s).

3.2.2 *master heat, n*—a single furnace charge of alloy that may be either poured directly into castings or into remelt alloy for individual melts.

3.2.3 *investment casting, n*—a metal casting that is produced in a mold obtained by investing (surrounding) an expendable pattern with a ceramic slurry which is allowed to solidify. The expendable pattern may consist of wax, plastic, or other material and is removed prior to filling the mold with liquid metal.

3.2.4 *subheat, n*—a portion of master heat remelted with only minor additions for deoxidation for pouring into castings. Syn. melt, production heat.

## 4. Materials and Manufacture

4.1 *Melting Process*—Master heats shall be made by the electric furnace process with or without separate refining such as argon-oxygen-decarburization (AOD), vacuum-oxygen-degassing (VOD), vacuum-induction-melting (VIM), etc., unless otherwise specified in the individual specification or agreed upon between the customer and producer. Master heats

**TABLE 1 Product Analysis Tolerances for Carbon and Low-Alloy Steels**

Element	Range <sup>A</sup>	Tolerances <sup>BC</sup> over max or under min, Limit, %
Carbon (C)	up to 0.65 % above 0.65 %	0.03 × % C <sub>L</sub> + 0.02 0.04 %
Manganese (Mn)	up to 1 % above 1 %	0.08 × % Mn <sub>L</sub> + 0.01 0.09
Silicon (Si)	up to 0.60 % above 0.60 %	0.22 × % Si <sub>L</sub> - 0.01 0.15 %
Phosphorus (P)	all	0.13 × % P <sub>L</sub> + 0.005
Sulfur (S)	all	0.36 × % S <sub>L</sub> + 0.001
Nickel (Ni)	up to 2 % above 2 %	0.10 × % Ni <sub>L</sub> + 0.003 0.25 %
Chromium (Cr)	up to 2 % above 2 %	0.07 × % Cr <sub>L</sub> + 0.04 0.18 %
Molybdenum (Mo)	up to 0.6 % above 0.6 %	0.04 × % Mo <sub>L</sub> + 0.03 0.06 %
Vanadium (V)	up to 0.25 % above 0.25 %	0.23 × % V <sub>L</sub> + 0.004 0.06 %
Tungsten (W)	up to 0.10 % above 0.10 %	0.08 × % W <sub>L</sub> + 0.02 0.02 %
Copper (Cu)	up to 0.15 % above 0.15 %	0.18 × % Cu <sub>L</sub> + 0.02 0.05 %
Aluminum (Al)	up to 0.10 % above 0.10 %	0.08 × % Al <sub>L</sub> + 0.02 0.03 %

<sup>A</sup>The range denotes the composition limits up to which the tolerances are computed by the equation, and above which the tolerances are given by a constant.

<sup>B</sup>The subscript<sub>L</sub> for the elements in each equation indicates that the limits of the element specified by the applicable specification are to be inserted into the equation to calculate the tolerance for the upper limit and the lower limit, if applicable, respectively. Examples of computing tolerances are presented in the footnote C.

<sup>C</sup>To compute the tolerances, consider the manganese limits 0.50 - 80 % of Grade WC4 of Specification A 217/A 217M. According to Table 1, the maximum permissible deviation of a product analysis below the lower limit 0.50 is 0.05 % = (0.08 × 0.50 + 0.01). The lowest acceptable product analysis of Grade WC4, therefore, is 0.45 %. Similarly, the maximum permissible deviation above the upper limit of 0.80 % is 0.074 % = (0.08 × 0.08 + 0.01). The highest acceptable product analysis of Grade WC4, therefore is 0.874. For Grade WCC of Specification A 216/A 216M, the maximum manganese content is 1.20 % if the carbon content is 0.20 %. In this case, the highest acceptable product analysis is 1.29 = (1.20 + 0.09).

may be used directly for producing castings or converted into ingot, bar, shot, or other suitable form, not including gates and risers from casting production, for later remelting as a subheat.

4.2 *Re-melting Process*—Subheats shall be produced from master heat metal in suitable batch sizes by electric induction

<sup>6</sup> Annual Book of ASTM Standards, Vol 03.05.

<sup>7</sup> Annual Book of ASTM Standards, Vol 03.01.

<sup>8</sup> Available from American National Standards Institute, 11 W. 42 nd St., 13th Floor, New York, NY 10036.

<sup>9</sup> Available from American Society of Mechanical Engineers, 345 E. 47th St., New York, NY 10017.

<sup>10</sup> Available from the Manufacturer's Standardization Society of the Valve and Fitting Industry, 127 Park St. NE, Vienna, VA 22180.

<sup>11</sup> Available from the Society of Automotive Engineers, Inc., 400 Commonwealth Drive, Warrendale, PA 15096-0001.

furnace, with or without atmosphere protection, such as vacuum or inert gas unless otherwise agreed upon between the customer and producer. Revert (gates, sprues, risers, and rejected) castings shall not be remelted except in master heats.

4.3 *Heat Treatment*— Ferritic and martensitic steel shall be cooled after pouring to provide substantially complete transformation of austenite prior to heat treatment to enhance mechanical properties.

4.4 *Sampling*

4.4.1 If castings are poured directly from one or more master heats, then the samples for chemical and other required testing also shall be poured directly from each of the master heats.

4.4.2 If castings are poured from a subheat, then the samples for chemical and other required testing also shall be poured from a subheat of that same master heat, but not necessarily from the same sub-heat as the castings. The subheat used for the test samples shall be produced using the same practices and additions as used for the castings.

4.4.3 Test specimens may be taken from castings or from coupons cast either integrally with the castings, in the same molds as the castings, or in separate molds.

4.4.4 Separately cast specimens for tension testing shall be cast in molds of the same type and material as those used for the castings, as shown in Fig. 1, Fig. 2 and Table 2, Fig. 3, and Fig. 4 except when Supplementary Requirement S26 is specified. The test coupon in Fig. 4 shall be employed only for austenitic alloy castings with cross sections less than 2-1/2in.<sup>12</sup>

5. **Chemical Composition**

5.1 *Chemical Analysis*—Chemical analysis of materials covered by this specification shall be in accordance with Test Methods, Practices, and Terminology A 751.

5.2 *Heat Analysis*— An analysis of samples obtained according to 4.4 or Supplementary Requirement S27 as appropriate, shall be made by the manufacturer to determine the percentages of the elements specified for the grade being

poured. When drillings are used, they shall be taken not less than 1/16 in. (1.6 mm) beneath the surface. The chemical composition thus determined shall be reported to the purchaser, or his representative; and shall conform to the requirements in the individual specification for the grade being poured.

5.3 *Product Analysis*— A product analysis may be made by the purchaser from material representing each master heat, subheat, lot, or casting. The analysis shall be made on representative material. Samples for carbon analysis shall be taken no closer than 1/16 in. (1.6 mm) to a cast surface except that castings too thin for this shall be analyzed on representative material. The chemical composition thus determined shall meet the requirements specified in the applicable specification for the grade involved, or shall be subject to rejection by the purchaser, except that the chemical composition determined for carbon and low-alloy steel castings may vary from the specified limits by the amounts shown in Table 1. The product analysis tolerances of Table 1 are not applicable as acceptance criteria for heat analysis by the casting manufacturer. When comparing product and heat analysis for other than carbon and low alloy steels, the reproducibility data R2, in Test Methods E 353 or E 354, as applicable, shall be taken into consideration.

5.4 *Unspecified Elements*—When chemical analysis for elements not specified for the grade ordered is desired, Supplementary Requirement S1 may be specified.

NOTE 1—All commercial metals contain small amounts of various elements in addition to those which are specified. It is neither practical nor necessary to specify limits for every unspecified element that might be present, despite the fact that the presence of many of these elements often is determined routinely by the producer.

5.5 The substitution of a grade or composition different from that specified by the purchaser is prohibited.

6. **Mechanical Test Methods**

6.1 All mechanical tests shall be conducted in accordance with Test Methods and Definitions A 370.

7. **Tensile Requirements**

7.1 Sampling for tension testing shall be in accordance with 4.4 or with Supplementary Requirement S28 as appropriate.

7.2 The coupon from which the test specimen is taken shall be heat-treated in production furnaces to the same procedure as the castings it represents.

<sup>12</sup> Information on the relationship of mechanical properties determined on test coupons obtained as specified in 4.4.4 with those obtained from the casting may be found in "The Steel Castings Handbook," Fifth Edition, Steel Founders' Society of America, 1980, pp. 15-35 through 15-43.

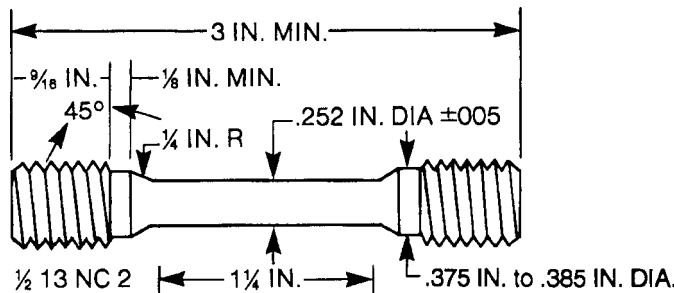

Metric Equivalents

in.	0.005	1/8	0.252	0.375	0.385	9/16	1 1/4	3
[mm]	[0.15]	[3]	[6.40]	[9.50]	[9.75]	[15]	[30]	[75]

FIG. 1 Design and Dimensions of the ICI Test Bar

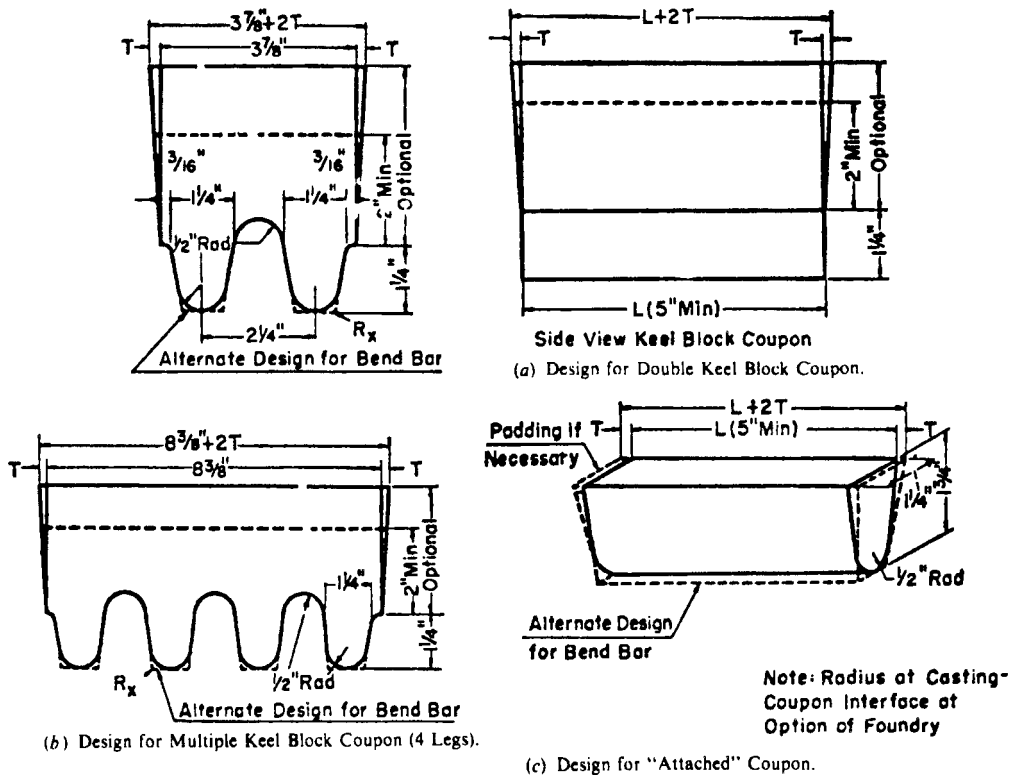

		Metric Equivalents							
In.	3/16	1/2	1/4	1 3/4	2	2 1/2	3/8	5	8 1/8
mm	4.8	13	32	45	51	57	98	127	213

FIG. 2 Test Coupons for Castings (see Table 2 for Details of Design)

TABLE 2 Details of Test Coupon Design for Casting (See Fig. 2)

NOTE 1—*Test Coupons for Large and Heavy Steel Castings*: The test coupons in Fig. 2 are to be used for large and heavy steel castings. However, at the option of the foundry the cross-sectional area and length of the standard coupon may be increased as desired.

NOTE 2—*Bend Bar*: If a bend bar is required, an alternate design (as shown by dotted lines in Fig. 2) is indicated.

	Leg Design [125 mm]		Riser Design
1. <i>L</i> (length)	A 5 in. [125 mm] minimum length will be used. This length may be increased at the option of the foundry to accommodate additional test bars (see Note 1).	1. <i>L</i> (length)	The length of the riser at the base will be the same as the top length of the leg. The length of the riser at the top therefore depends on the amount of taper added to the riser.
2. End taper	Use of and size of end taper is at the option of the foundry.	2. Width	The width of the riser at the base of a multiple-leg coupon shall be $n, 2 \frac{1}{4}$ [57 mm] - $\frac{5}{8}$ [16 mm] where <i>n</i> equals the number of legs attached to the coupon. The width of the riser at the top is therefore dependent on the amount of taper added to the riser.
3. Height	1 1/4 in. [32 mm]	3. <i>T</i> (riser taper)	Use of and size is at the option of the foundry.
4. Width (at top)	1 1/4 in. [32 mm] (see Note 1).	Height	The minimum height of the riser shall be 2 in. [51 mm]. The maximum height is at the option of the foundry for the following reasons: (a) Many risers are cast open, (b) different compositions may require variation in risering for soundness, (c) different pouring temperatures may require variation in risering for soundness.
5. Radius (at bottom)	1/2 in. [13 mm], max		
6. Spacing between legs	A 1/2-in. [13-mm] radius will be used between the legs.		
7. Location of test bars	The tensile, bend, and impact bars will be taken from the lower portion of the leg (see Note 1).		
8. Number of legs	The number of legs attached to the coupon is at the option of the foundry providing they are equispaced according to Item 6.		
9. <i>R<sub>s</sub></i>	Radius from 0 to approximately 1/16 in. [2mm].		

7.3 If any specimen shows defective machining or develops flaws, it may be discarded and another substituted from the same heat.

7.4 To determine conformance with the tension test requirements, an observed value or calculated value shall be rounded off in accordance with Practice E 29 to the nearest 500 psi (51

MPa) for yield and tensile strength and to the nearest 1 % for elongation and reduction of area.

### 8. Repair by Welding

8.1 Repair by welding shall be in accordance with the requirements of individual specifications using procedures and

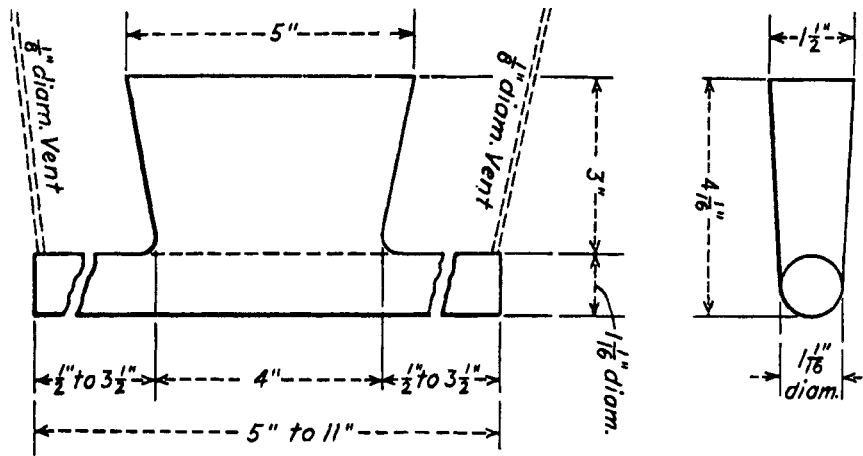

NOTE 1—Pour through head; cover molten head with powered charcoal, coke dust, etc., immediately after pouring, in order to keep head fluid as long as possible.

Metric Equivalents

in.	mm	in.	mm
1/8	3.2	3 1/2	88.9
1/2	12.7	4	101.6
1 1/16	27.0	4 1/16	103.2
1 1/2	38.1	5	127.0
3	76.2	11	279.4

FIG. 3 Test Block for Tension Test Specimen

welders qualified in accordance with Practice A 488/A 488M.

## 9. Flanges

9.1 When a flange from a flanged casting is removed to make a weld-end castings, discontinuities may be observed that would not have been detrimental in a flanged castings. The disposition of the casting shall be subject to agreement between the purchaser and manufacturer.

## 10. Quality

10.1 The surface of the casting shall be free of adhering ceramic, scale, cracks, and hot tears as determined by visual examination. Other surface discontinuities shall meet the visual acceptance standards specified in the order. Unacceptable visual surface discontinuities shall be removed and their removal verified by visual examination of the resultant cavities.

10.2 The castings shall not be peened, plugged, or impregnated to stop leaks.

10.3 When additional inspection is desired, Supplementary Requirements S4, S5, S7, or S10 may be specified.

## 11. Hydrostatic Tests

11.1 Each casting shall be tested after machining to the hydrostatic shell test pressures prescribed in ANSI B16.5 for the applicable steel rating for which the casting is designed. The casting shall not show any leaks. Castings ordered for working pressures other than those in the standard ANSI ratings, or those listed for which test pressures are not specified by ANSI B16.5, shall be tested at a pressure agreed upon between manufacturer and the purchaser.

11.2 It is realized that the foundry may be unable to perform the hydrostatic test prior to shipment, or that the purchaser may

wish to defer testing until additional work or machining has been performed on the casting. Castings ordered in the rough state for final machining by the purchaser may be tested hydrostatically prior to shipment by the manufacturer at pressures to be agreed upon with the purchaser. The foundry, however, is responsible for the satisfactory performance of the casting under the final test required in 11.1.

## 12. Workmanship, Finish, and Appearance

12.1 All castings shall be made in a workmanlike manner and shall conform to the dimensions on drawings furnished by the purchaser. When the pattern is supplied by the purchaser or is produced using a die supplied by the purchaser, the dimensions of the casting shall be as predicated by the pattern or die unless otherwise agreed upon.

12.2 Machined welding ends shall be suitably protected against damage during shipping.

## 13. Retests

13.1 If the results of the mechanical tests do not conform to the requirements specified, retests are permitted as outlined in Test Methods and Definitions A 370. At the manufacturer's option, castings may be reheat-treated and retested. Testing after reheat treatment shall consist of the full number of specimens taken from locations complying with the specification or order.

## 14. Inspection

14.1 The manufacturer shall afford the purchaser's inspector all reasonable facilities necessary to satisfy that the material is being produced and furnished in accordance with the applicable specification. Foundry inspection by the purchaser shall not interfere unnecessarily with the manufacturer's operations.

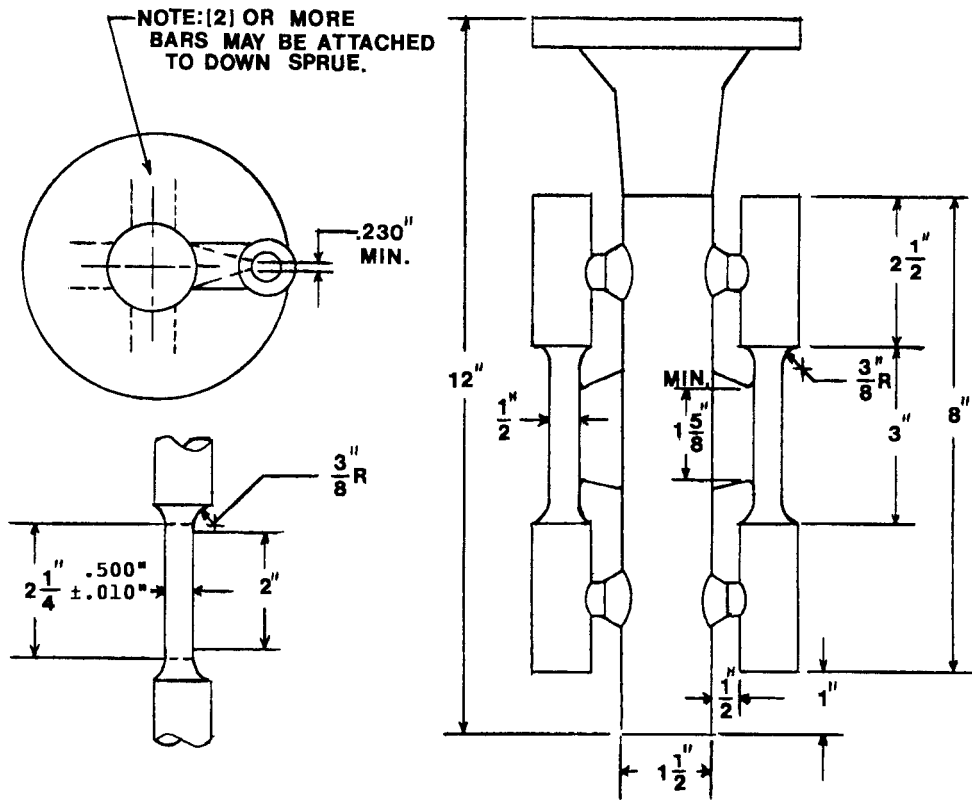

NOTE 1—Coupons produced in this manner are suitable for austenitic alloys only. The mold may be preheated for pouring to produce a sound coupon.

Metric Equivalents

in.	mm	in.	mm
0.010	0.254	1 5/8	41.275
0.0230	5.842	2 1/4	57.15
3/8	9.525	2 1/2	63.5
1/2	12.7	3	76.2
1	25.4	8	203.2
1 1/2	38.1	12	304.8

FIG. 4 Cast-To-Shape Test Coupon for Tension Test Specimen

All tests and inspections, with the exception of product analysis (5.2), are the responsibility of the manufacturer.

### 15. Rejection and Rehearing

15.1 Any rejection based on test reports shall be reported to the manufacturer within 30 days from the receipt of the test reports by the purchaser.

15.2 Material that shows unacceptable discontinuities as determined by the acceptance standards specified in the order subsequent to its acceptance at the manufacturer's works will be rejected, and the manufacturer shall be notified within 30 days after discovery of the rejectable condition.

15.3 Samples that represent rejected material shall be preserved for two weeks from the date of transmission of the test report. In case of dissatisfaction with the results of the tests, the manufacturer may make claim for a rehearing with that time.

### 16. Certification

16.1 The manufacturer's certification shall be furnished to the purchaser stating that the material was manufactured, sampled, tested, and inspected in accordance with the material

specification (including year of issue) and was found to meet the requirements.

16.2 As applicable, the certification also shall include:

16.2.1 Material specification and grade.

16.2.2 Pattern or part number.

16.2.3 Master heat number or serial number traceable to the master heat number.

16.2.4 Chemical analysis results required by the specification and supplementary requirements specified in the purchase order.

16.2.5 Mechanical property results required by the specification and supplementary requirements specified in the purchase order.

16.2.6 Statement of satisfactory inspection, visual, and non-destructive testing specified in the purchase order.

16.2.7 Manufacturer's name, and

16.2.8 Additional purchase order requirements.

16.3 A signature is not required on the certification; however, the document shall identify clearly the organization submitting the certification. Notwithstanding the absence of a

signature, the organization submitting the certification is responsible for its content.

## 17. Product Marking

17.1 Castings shall be marked for material identification with the grade symbols (WCB, WC9, CF8M, etc.). In addition, master heat numbers, or serial numbers that are traceable to master heat numbers, shall be marked on all pressure-containing casting individually weighing 50 lb (25 kg) or more. Pressure-containing castings weighing less than 50 lb (25 kg) shall be marked with either the master heat number or a lot number that will identify the casting as to the month in which it was poured. Marking shall be in such position as not to injure

the usefulness of the casting.

17.2 On casting for which impact property requirements are specified, stamped markings using low-stress stamps shall be on a raised pad when such pad can be made a part of the castings.

17.3 Castings shall be marked with the manufacturer's identification or symbols except when other provisions have been made between the manufacturer and purchaser.

## 18. Keywords

18.1 casting; investment casting; master heat; pressure containing; steel casting; subheat

## SUPPLEMENTARY REQUIREMENTS

The following standardized supplementary requirements are for use when desired by the purchaser and when allowed by and listed in the individual specifications. They shall not apply unless specified in the order, in which event the specified tests shall be made by the manufacturer before shipment of the castings.

### S1. Unspecified Elements

S1.1 Limits may be established for elements not specified for the grade ordered by agreement between the manufacturer and purchaser. The results of the analysis for the agreed upon elements shall be reported.

### S2. Destruction Tests

S2.1 Purchaser may select representative castings from each heat and cut up and etch, or otherwise prepare, the sections for examination for internal defects. Should injurious defects be found that evidence unsound steel or faulty foundry technique, all of the castings made from that particular pattern, heat, and heat treatment charge may be rejected. All other rejected castings, including those cut up, shall be replaced by the manufacturer without charge.

### S3. Bend Test

S3.1 One bend test shall be made from a test coupon from each master heat in accordance with Test Methods and Definitions A 370, and shall be machined to 1 by ½ in. (25 by 13 mm) section with corners rounded to a radius not over ¼ in. (1.6 mm).

S3.2 The specimen shall withstand being bent longitudinally at room temperature through an angle of 90° about a pin the diameter of which shall be the specimen thickness for carbon steels, and 1 in. (25 mm) for other steels. The specimen shall show no cracks on the outside of the bent portion of the specimen.

S3.3 Bend test specimens may be cut from heat-treated castings instead of from test bars when agreed upon between manufacturer and purchaser.

S3.4 If any test specimen shows defective machining or develops flaws, it may be discarded and another specimen substituted from the same heat.

### S4. Magnetic Particle Inspection

S4.1 Castings shall be examined for surface and near

surface discontinuities by magnetic particle inspection. The examination shall be in accordance with Guide E 709, and types and degrees of discontinuities considered, shall be judged by the Reference Photographs E 125. Extent of examination, time of examination, and basis for acceptance shall be agreed upon between the manufacturer, and purchaser. Specification, which may be used as a basis for such agreement, are Specifications A 903/A 903M and MSS SP 53.

S4.2 Personnel performing the examination shall be qualified in accordance with an acceptable written practice.

### S5. Radiographic Inspection

S5.1 Castings shall be examined for internal defects by means of X-rays or gamma rays. The procedure shall be in accordance with Guide E 94 and types and degrees of discontinuities considered shall be judged by Reference Radiographs E 136, E 192, E 280, or E 446. Extent of examination and basis for acceptance shall be agreed upon between the manufacturer and purchaser. A specification that may be used as a basis for such agreement is MSS SP 54.

S5.2 Radiographic examination of castings may be performed before or after any heat treatment.

S5.3 Personnel performing the examination shall be qualified in accordance with an acceptable written practice.

### S6. Liquid Penetrant Inspection

S6.1 Castings shall be examined for surface discontinuities by means of liquid penetrant inspection. The examination shall be in accordance with Test Method E 165. Areas to be inspected, time of inspection, methods and types of liquid penetrants to be used, developing procedure, and basis for acceptance shall be agreed upon between the manufacturer and purchaser. A specification which may be used as a basis for such agreement is A 903/A 903M.

S6.2 Personnel performing the examination shall be qualified in accordance with an acceptable written practice.

## **S7. Ultrasonic Inspection**

S7.1 Castings shall be examined for internal defects by means of ultrasonic inspection. The inspection procedure shall be in accordance with Practice A 609/A 609M. Extent of examination methods of testing, and basis for acceptance shall be agreed upon between the manufacturer and purchaser.

S7.2 Ultrasonic examination of casting of carbon and low-alloy steels shall be performed after at least one heat treatment above the critical temperature range but need not be repeated after subsequent heat treatment.

S7.3 Personnel performing the examination shall be qualified in accordance with an acceptable written practice.

## **S8. Charpy Impact Test**

S8.1 Charpy impact test properties shall be determined on each master heat from a set of three Charpy V-notch specimens made from a test coupon in accordance with Test Methods and Definitions A 370, and tested at a test temperature agreed upon by the manufacturer and purchaser. The sampling requirements shall be agreed upon between the manufacturer and purchaser (see 4.4). The acceptance requirements shall be energy absorbed, lateral expansion, percent shear area or any combination thereof, and shall be agreed upon by the manufacturer and purchaser. Test specimens shall be prepared as Type A and tested in accordance with Test Methods and Definitions A 370.

S8.2 *Absorbed Energy*—Average energy value of three specimens shall not be less than specified, with not more than one value permitted to fall below the minimum specified and no value permitted below the minimum specified for a single specimen.

S8.3 *Lateral Expansion*—Lateral expansion value shall be agreed upon by the manufacturer and purchaser.

S8.4 *Percent Shear Area*—Percent shear area shall be agreed upon by the manufacturer and purchaser.

## **S9. Drop Weight Tests**

S9.1 Drop weight test properties shall be determined from each heat by preparing and testing either Type P1, P2, or P3 specimens in accordance with Test Methods E 208. The crack starter weld shall be deposited on the surface of the specimen that was nearest to the casting surface. Each test shall consist of at least two specimens tested at a temperature agreed upon by the manufacturer and purchaser. Each specimen shall exhibit “no break” performance.

## **S10. Examination of Weld Preparation**

S10.1 Magnetic particle or liquid penetrant examination of cavities prepared for welding shall be performed to verify removal of those discontinuities found unacceptable by the inspection method specified for the casting. The method of performing magnetic particle or liquid penetrant examination shall be in accordance with either Guide E 709 or Test Method E 165. Unless other degrees of shrinkage or types of discontinuities found in the cavities are specified, Type II, Internal Shrinkage, of Reference Photographs E 125, of Degree 2 in sections up to 2-in. (50-mm) thick, and of Degree 3 in sections over 2-in. (50-mm) thick shall be acceptable.

## **S11. Prior Approval of Major Weld Repairs**

S11.1 Major weld repairs shall be subject to the prior

approval of the purchaser.

## **S12. Hardness Test**

S12.1 A hardness test shall be made in accordance with Test Methods and Definitions A 370. The test location and the hardness requirements shall be agreed upon between the manufacturer and the purchaser.

## **S14. Tension Test From Each Heat and Heat Treatment Charge**

S14.1 One tension tests shall be made for each master heat and heat-treatment charge combination.

## **S15. Quench and Temper Heat-Treatment**

15.1 The castings shall be quenched and tempered. Castings so treated shall be marked QT.

## **S17. Tension Test From Castings**

S17.1 In addition to the tensile test required in Section 6, test material shall be cut from heat treated castings. The mechanical properties and location for the test material shall be agreed upon by the manufacturer and purchaser.

## **S20. Weld Repair Charts**

S20.1 Major weld repairs shall be documented by means of sketches or photographs or both showing the location and major dimensions of cavities prepared for welding. Documentation shall be submitted to the purchaser at the completion of the order.

S20.2 A weld repair shall be considered major when it is made to correct leakage on hydrostatic testing, or when the depth of the cavity prepared for welding exceeds 20 % of the actual wall thickness or 1 in. (25 mm), whichever is smaller, or when the extent of the cavity exceeds approximately 10 in.<sup>2</sup> (65 cm<sup>2</sup>).

## **S21. Heat-Treatment Furnace Record**

S21.1 A heat treatment chart showing time and temperature shall be prepared and be available for inspection by the purchaser.

## **S22. Heat Treatment**

S22.1 Test specimens shall be heat-treated together with the castings they represent. Heat-treated specimens shall be tested and shall meet the tensile and impact properties specified.

S22.2 The remaining test specimens from Supplementary Requirement S22.1 representing the casting shall be treated thermally after the final (foundry) heat-treatment to simulate heat-treatments below the critical temperature, which the casting may receive during fabrication, and then tested for mechanical properties. Time, temperature, and cooling rate shall be as stated in the order. In the case of postweld heat-treatment, the total time at temperature or temperatures for the test material shall be at least 80 % of the total time at temperature or temperatures during actual postweld heat-treatment of the fabrication of which the casting or castings are a part. The total time at temperature or temperatures for the test material may be performed in a single cycle. When this



Supplementary Requirement is specified, the welding qualification test metal must be processed in the same manner.

**S23. Macroetch Test**

S23.1 Apply Supplementary Requirement S1 for the spectrographic determination and reporting of the total residual aluminum content of all heats of ferritic and martensitic steels subjected to this macroetch test.

S23.2 When the heat analysis indicates a total residual aluminum content in excess of 0.08 %, the manufacturer shall etch a cross section of the casting with the heaviest section for which this supplementary requirement is invoked, or a coupon attached to that heaviest section or an area directly under a riser (see Note S23.1). Cross sections, from a separately cast test block from the same heat and a thickness representative of the heaviest section of castings purchased under this supplementary requirement, also may be used for macroetch testing. The etching shall be performed on the selected section after its heat-treatment, that is, after annealing, normalizing, or quenching and tempering following the initial cooling of the steel below the transformation range.

NOTE S23.1—High-strength martensitic castings, in particular, may be damaged beyond use if the etch is applied directly to the casting.

S23.3 The preparation of the surface and the macroetching procedure with solution No. 1 (1:1 HC1) of Table 5 in Test Method E 340 shall be followed. The resulting etched surface shall be compared and rated with the reference photographs in Fig. S23.1 depicting ten levels of severity of intergranular

network structures indicative of the presence of aluminum nitride, or other constituents prone toward precipitating at grain boundaries during solidification and subsequent cooling. Table S23.1 relates the severity levels shown in these photographs with specific delineation widths and percent of boundary outlining in the etched structures.

S23.4 Castings represented by etched structures exhibiting a network rating in excess of Severity Level 4 shall be considered unacceptable until further evaluations are completed. The acceptability of individual castings may be determined by etching sections of each casting to ascertain the network severity level. Disposition of unacceptable castings shall be a matter of agreement between the manufacturer and purchaser. Those castings exhibiting etched severity levels greater than four may be further evaluated by any of the following agreed upon methods.

S23.4.1 Fracture testing to determine the amount of “rock candy” structure.

S23.4.2 Mechanical testing (bend, tensile, etc.) to determine the ductility characteristics.

S23.4.3 Weld testing to determine crack susceptibility in the heat-affected zone of a circular groove welded with cellulose coated electrodes.

S23.5 Alternatively, by agreement, it is permissible to subject castings from an unacceptable heat to a high temperature solution treatment prior to the normal production heat-treatment and subsequently macroetch test each casting.

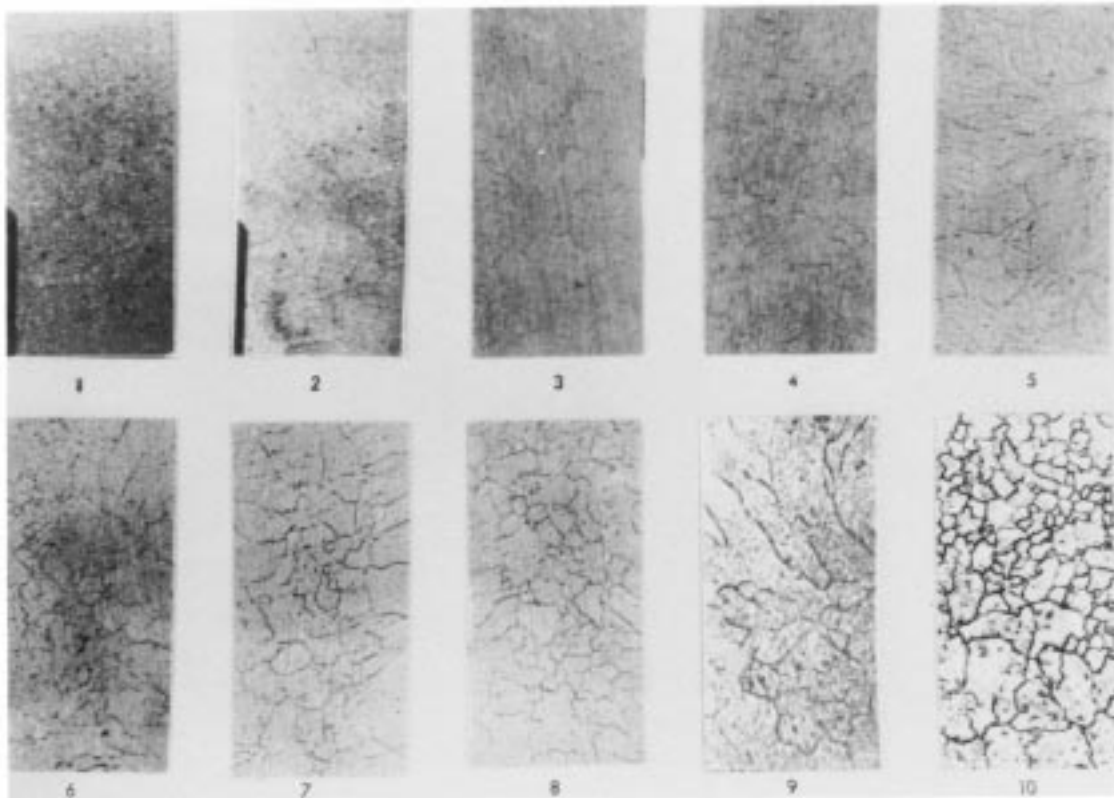

NOTE—The 10 levels of severity of intergranular network structures shown are indicative of the presence of aluminum nitride precipitation in the primary austenitic grain boundaries.

**FIG. S23.1 Reference Photographs of Macroetched Cast Steel**

**TABLE S23.1 Descriptive Data Applicable to Network Structures Shown in Fig. S23.1**

NOTE—These ratings are based on the physical width and continuity of the precipitate pattern developed by the acid etchant on the primary austenitic grain boundaries of the cast steel. Supplementary testing is normally conducted to determine the final disposition of castings with ratings of 5 or greater.

Rating	Delineation Width, in.	Boundary Outline, %
1	Fine-0.001	20
2	Fine-0.001	40
3	Fine-0.001	60
4	Fine-0.002	80
5	Fine-0.002	100
6	Medium-0.005	100
7	Heavy-0.010	100
8	0.020	100
9	1/32	100
10	1/16	100

## S24. Specified Ferrite Content Range

S24.1 The chemical composition of the heat shall be controlled such that the ferrite content, as determined by the chemical composition procedure of Practice A 800/A 800M, shall be in conformance with the specified ferrite content range.

S24.2 The specified ferrite content range shall be as agreed upon between the manufacturer and the purchaser. The minimum specified ferrite content range shall be 10 % with the minimum ferrite content being no lower than the percent necessary to achieve the minimum mechanical properties required for the alloy.

S24.3 Should the purchaser wish to have the ferrite content determined by either magnetic response or metallographic methods, the purchaser should impose supplementary requirement S1 or S2 of Practice A 800/A 800M.

## S25. Heat-Treatment Certification

S25.1 Heat treatment temperature and cycle times shall be shown on the certification report.

## S26. Alternative Tension Test Coupons and Specimen Locations for Castings (In-Lieu of Test Bars Poured from Special Blocks)

S26.1 Test blocks may be cast integrally with the castings or as separate blocks. Test blocks shall be heat-treated together with the castings they represent.

S26.2 The casting thickness,  $T$ , is the maximum thickness of the pressure containing wall of the casting exclusive of padding added for directional solidification, flanges, appendages, and sections designated by the designer as noncritical. The order, inquiry, and drawing shall designate what the test dimension,  $T$ , is for the casting.

S26.3 One of the following shall apply:

S26.3.1 The longitudinal centerline of the test specimen shall be taken at least  $1/4 T$  from the  $T$  dimension surface and all of the gage length must be at least  $1 T$  from any other heat-treated surface, exclusive of the surface opposite the  $T$  dimension surface (see Fig. S26.1 (a)). For cylindrical castings,

the longitudinal centerline of the specimens shall be taken at least  $1/4 T$  from the outside or inside and all of the gage length must be at least  $T$  from the as-heat treated end (see Fig. S26.1 (b)).

S26.3.2 For ferritic and martensitic castings, partial severing of test blocks prior to final heat treatment is permitted.

S26.3.3 Where separately cast test coupons are used, the dimensions shall not be less than  $3T$  by  $3 T$  by  $T$  and each specimen shall meet the requirements of S26.3.1, except that when  $T$  exceeds 5 in. (125 mm), the dimension may be 15 by 15 by 5 in. (375 by 375 by 125 mm), by agreement between the manufacturer and the purchaser. The test coupon shall be of the same heat of steel and shall receive substantially the same casting practices as the production casting it represent (see Fig. S26.2).

S26.3.4 When agreed upon between the manufacturer and the purchaser, castings that are cast or machined to essentially the finished configuration prior to heat-treatment, shall have test specimens removed from a prolongation or other stock on the casting at a location below the nearest heat-treated surface indicated on the order. The specimen location shall be at a distance below the nearest heat-treated surface equivalent to at least the greatest distance that the indicated high-tensile stress surface will be from the nearest heat-treated surface and a minimum of twice this distance from a second heat-treated surface, except that the test specimens shall be no nearer than  $3/4$  in. (19 mm) to a heat-treated surface and  $1-1/2$  in. (33 mm) from a second heat-treated surface (see Fig. S26.3).

S26.3.5 Where specimens are to be removed from the body of quenched and tempered castings, either the requirement of S22.3.1 shall be met or a steel thermal buffer pad or thermal insulation or other thermal barriers shall be used during heat-treatment. Steel thermal buffer pads shall be a minimum of  $T$  by  $T$  by  $3T$  in length and shall be joined to the casting surface by a partial penetration weld completely sealing the buffered surface. Test specimens shall be removed from the casting in a location adjacent to the center third of the buffer pad. They shall be located at a minimum distance of  $1/2$  in. (13 mm) from the buffered surface and  $1/4 T$  from other heat-treated surfaces (see Fig. S26.4). When thermal insulation is used, it shall be applied adjacent to the casting surface where the test specimens are to be removed. The producer shall demonstrate that the cooling rate of the test specimen location is no faster than that of specimens taken by the method described in S26.3.1.

## S27. Increased Testing Frequency—Chemical Analysis

S27.1 Frequency of chemical analysis shall be as agreed upon between the purchaser and manufacturer.

## S28. Increased Testing Frequency—Tensile Testing

S28.1 Frequency of tension tests shall be as agreed upon between the purchaser and manufacturer.

## S29. Decarburization

S29.1 A representative casting or coupon shall be evaluated for total or complete decarburization, or both, in accordance with ARP 1341.

S29.2 The basis for acceptance shall be agreed upon between the purchaser and manufacturer. An example of an

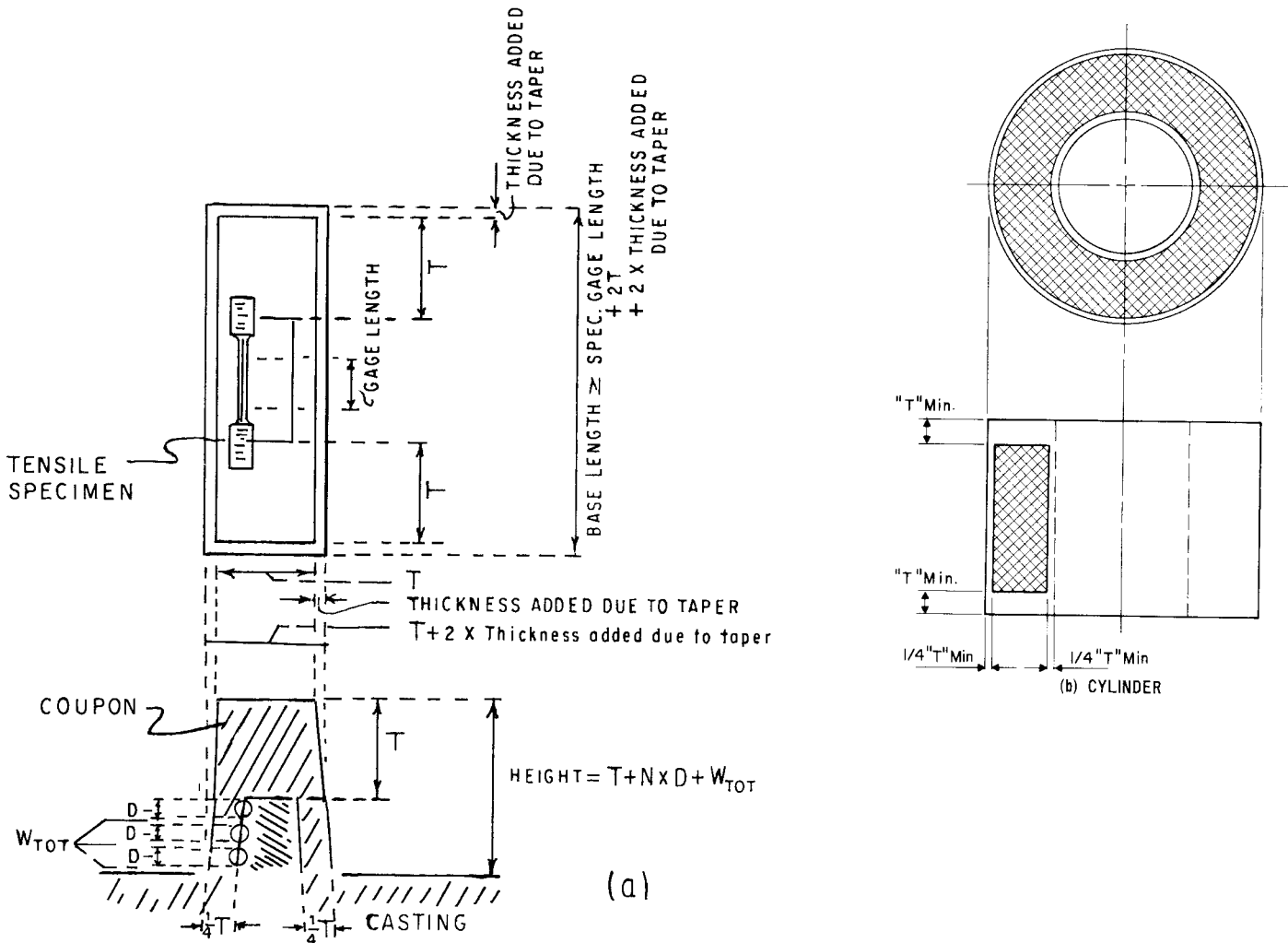

Minimum length of the base — Specimen gage length +  $2xT$  +  $2x$  the thickness due to the taper.  
 Minimum length of the base —  $T + 2x$  the thickness added due to the taper.  
 Minimum height —  $T + NxD + W_{tot}$ .

The taper is to be selected by the producer for ease of drawing the pattern from the mold.  
 where:

- $N$  = number of specimens to be cut from one side of the coupon,
- $D$  = diameter of the specimens, and
- $W_{tot}$  = total width of metal required to remove the coupon from the casting, and to machine specimens from the coupon.

NOTE—Longitudinal axis and gage length of test specimen must be within shaded zone.

FIG. S26.1 Specimen from Casting

acceptance specification is zero total decarburization and no more than 0.020 in. partial decarburization.

### S30. Metallurgical Cleanliness

S30.1 After polishing, each casting shall be visually inspected for nonmetallic inclusions and porosity.

S30.2 The details of the method for inspection and the basis for acceptance shall be agreed upon between the purchaser and manufacturer.

S30.3 It is realized that the foundry may be unable to perform the inspection for metallurgical cleanliness prior to shipment, or that the purchaser may wish to defer inspection until after additional work or machining has been performed on the casting. The foundry, however, is responsible for the satisfactory performance of the castings under the final inspection required in S30.1

A 985

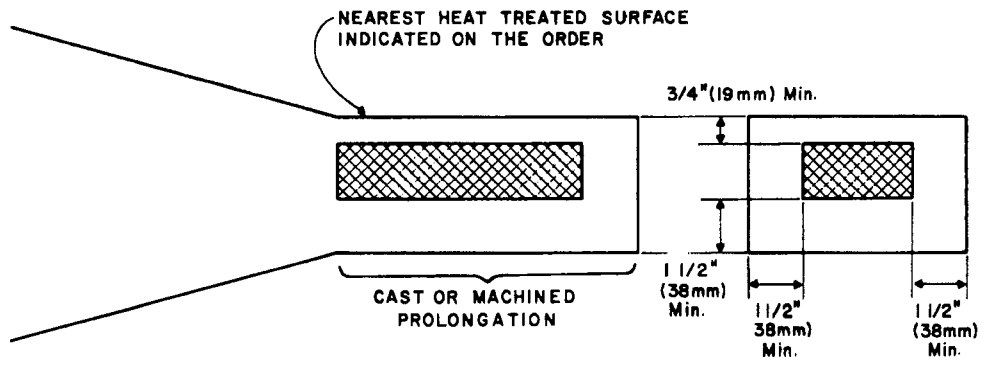

NOTE—Longitudinal axis and gage length of test specimen must be within cross-hatched zone.

FIG. S26.2 Prolongation Test Specimen

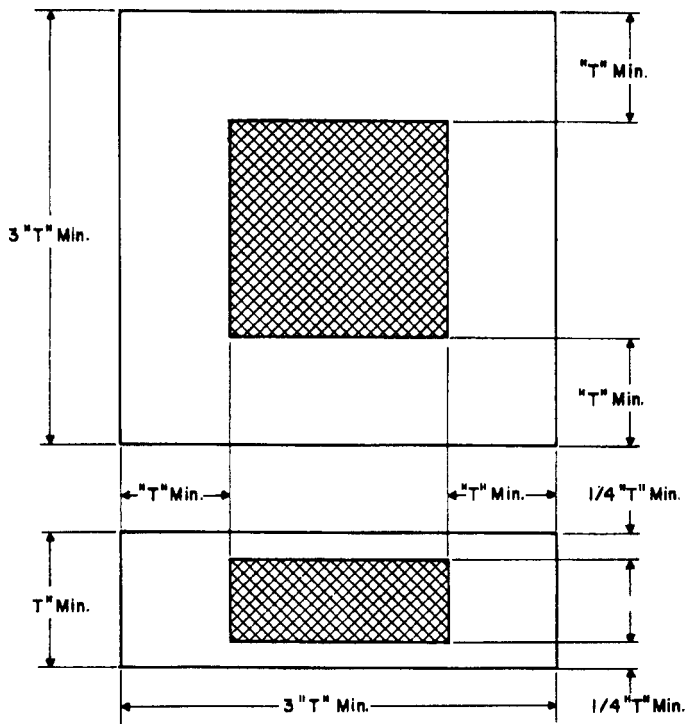

NOTE—Longitudinal axis and gage length of test specimen must be within cross-hatched zone.

FIG. S26.3 Separately Cast Block

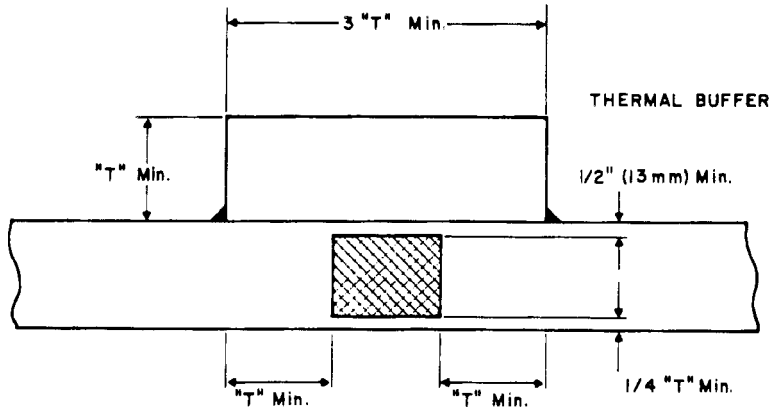
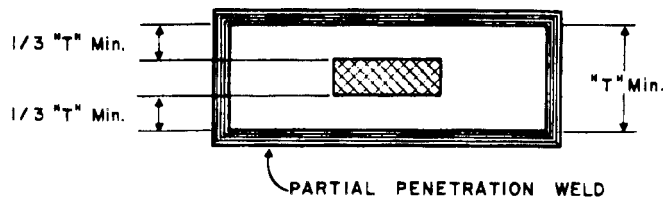

NOTE—Longitudinal axis and gage length of test specimen must be within cross-hatched zone.

FIG. S26.4 Thermal Buffer Pads

## APPENDIX

(Nonmandatory Information)

### X1. ALLOY DESIGNATIONS FOR CAST STAINLESS STEELS

X1.1 Cast stainless steels usually are specified on the basis of composition using the alloys designation system established by the Alloy Casting Institute (ACI). The ACI designations, for example, CF8M, have been adopted by ASTM and are preferred for cast alloys over the designations used by the American Iron and Steel Institute for similar wrought steels.

X1.2 This nomenclature system has served successfully to accommodate changes in old alloys and to designate new ones.

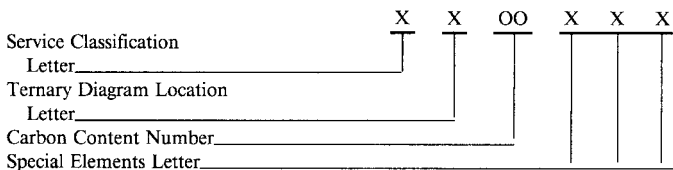

X1.2.1 *Service Classification Letter*—The first letter of the cast stainless steel designation system identifies the intended service application of the alloy. The letter *C* indicates corrosion-resistant service, and the letter *H* indicates the heat-resistant service at and above 1200°F (650°C).

X1.2.2 *Ternary Diagram Location Letter*—The second let-

ter indicates the approximate location of the nickel and chromium contents of the alloy grade on the FeCrNi ternary diagram shown in Fig. X1.1.

X1.2.3 *Carbon Content Number*—For *C* service classifications, this single or dual digit numeral represents the maximum carbon content in units of 0.01 %. For *H* service classifications, this number represents the midpoint of the range of carbon content in terms of 0.01 % with a  $\pm 0.05$  % limit.

X1.2.4 *Special Elements Letters*—Additional letters following the numeral represents special chemical elements in the alloy grade, such as *M* for molybdenum, *C* for columbium, *Cu* for copper, and *W* for tungsten. There are two exceptions. The letter *A* indicates “Controlled Ferrite,” and the letter *F* indicates “Free Machining.”

X1.3 In Fig. X1.1, unlettered NiCr ranges are associated with the nearest lettered location. They may be the result of differences between corrosion and heat-resistance types or because of the influence of additional elements, for example, the precipitation hardening grade CB-7 Cu.

LOCATION OF ACI ALLOY TYPES

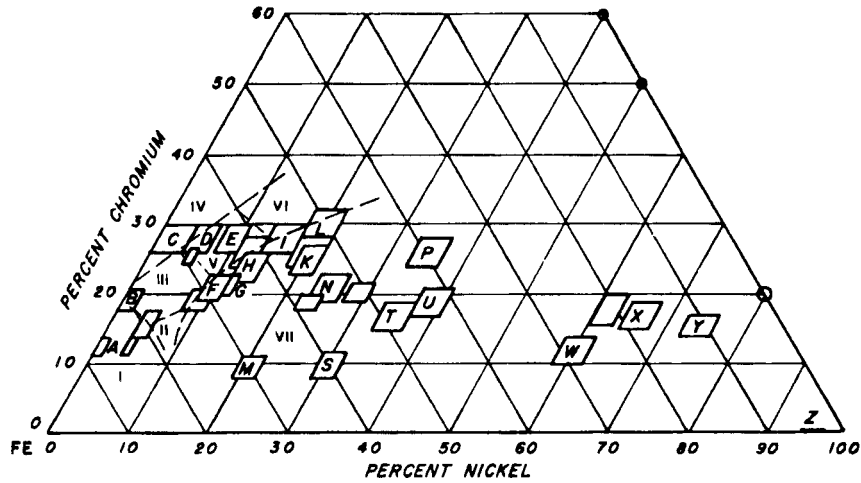

NOTE—The approximate areas of microstructures to be expected at room temperature are indicated as follows:

- I-Martensite
  - II-Martensite and untransformed austenite
  - III-Ferrite plus martensite and untransformed austenite
  - IV-Ferrite
  - V-Ferrite plus austenite
  - VI-Ferrite plus austenite plus sigma
  - VII-Austenite
- Carbides also may be present depending on carbon content and thermal history.

**FIG. X1.1 Letters Assigned to Chromium and Nickel Ranges in ACI Designation System**

*The American Society for Testing and Materials takes no position respecting the validity of any patent rights asserted in connection with any item mentioned in this standard. Users of this standard are expressly advised that determination of the validity of any such patent rights, and the risk of infringement of such rights, are entirely their own responsibility.*

*This standard is subject to revision at any time by the responsible technical committee and must be reviewed every five years and if not revised, either reapproved or withdrawn. Your comments are invited either for revision of this standard or for additional standards and should be addressed to ASTM Headquarters. Your comments will receive careful consideration at a meeting of the responsible technical committee, which you may attend. If you feel that your comments have not received a fair hearing you should make your views known to the ASTM Committee on Standards, at the address shown below.*

*This standard is copyrighted by ASTM, 100 Barr Harbor Drive, PO Box C700, West Conshohocken, PA 19428-2959, United States. Individual reprints (single or multiple copies) of this standard may be obtained by contacting ASTM at the above address or at 610-832-9585 (phone), 610-832-9555 (fax), or service@astm.org (e-mail); or through the ASTM website (www.astm.org).*