



Standard Specification for Mechanical Couplings Using Thermoplastic Elastomeric (TPE) Gaskets for Joining Drain, Waste, and Vent (DWV), Sewer, Sanitary, and Storm Plumbing Systems for Above and Below Ground Use¹

This standard is issued under the fixed designation C 1461; the number immediately following the designation indicates the year of original adoption or, in the case of revision, the year of last revision. A number in parentheses indicates the year of last reapproval. A superscript epsilon (ϵ) indicates an editorial change since the last revision or reapproval.

1. Scope

1.1 This specification describes the properties of devices or assemblies suitable for use as mechanical couplings using thermoplastic elastomeric (TPE) gaskets, hereinafter referred to as couplings, for joining drain, waste, and vent (DWV) sewer, sanitary, and storm plumbing systems for above and below ground use.

1.2 The pipe to be joined shall be of similar or dissimilar materials or size, or both.

1.3 The values stated in inch-pound units shall be regarded as standard. The values given in parentheses are for information only.

1.4 The ASTM standards referenced herein shall be considered mandatory.

2. Referenced Documents

2.1 ASTM Standards:

A 240/A 240M Specification for Heat-Resisting Chromium and Chromium-Nickel Stainless Steel Plate, Sheet, and Strip for Pressure Vessels²

A 493 Specification for Stainless and Heat-Resisting Steel Wire and Wire Rods for Cold Heading and Cold Forging²

A 666 Specification for Annealed or Cold-Worked Austenitic Stainless Steel, Sheet, Strip, Plate and Flat Bar²

C 717 Terminology of Building Seals and Sealants³

C 1440 Specification for Thermoplastic Elastomeric (TPE) Gasket Materials for Drain, Waste and Vent (DWV), Sewer, Sanitary and Storm Plumbing Systems

D 2240 Test Method for Rubber Property—Durometer Hardness⁴

3. Terminology

3.1 *Definitions*—For definitions of terms used in this specification, see Terminology C 717.

3.2 *Definitions of Terms Specific to This Standard:*

3.2.1 *center stop*—an integral part of the gasket centered on its axial length intended to limit the insertion depth of the pipe to be coupled.

3.2.2 *fitting*—parts of a pipeline other than straight pipe, couplings, or valves.

3.2.3 *free torque*—the torque value expressed in lbf-in./ (N-m) when the clamp is tightened four revolutions of the screw nut. While in the free state, this value does not include any breakaway effects due to staking method or passage of the band ends beyond the screw heads.

3.2.4 *inserts*—a bushing or ring placed into the coupling socket to accommodate pipe materials of differing outside diameters.

3.2.5 *joint*—the completed assembly of parts consisting of the flexible transition coupling and the joined pipes or fittings, or both.

3.2.6 *lot*—a specific quantity of similar material or collection of similar units from a common source; the quantity offered for inspection and acceptance at any one time. A lot might comprise a shipment, batch, or similar quantity.

3.2.7 *mechanical couplings*—devices used to join between sections of plain end pipe or fittings of the same or different materials, of the same or different size, or any combination of materials and pipe sizes.

3.2.8 *plain-end pipe*—any pipe that does not include any bell, hub, threaded area, or other means of joining.

3.2.9 *shear ring*—an interior or exterior element which is used to span the distance between the pipe ends within a coupling so as to provide increased resistance to axial displacement.

4. Classification

4.1 The couplings shall have a center stop unless telescoping of the pipe is necessary for special applications. The components shall be designed so that the elastomeric material is compressed to form a hydrostatic seal when the joint is assembled. The couplings shall be of the types described in 4.1.1-4.1.3.

4.1.1 *Unshielded*—A coupling consisting of an elastomeric

¹ This specification is under the jurisdiction of ASTM Committee C24 on Building Seals and Sealants and is the direct responsibility of Subcommittee C24.75 on Gaskets and Couplings for Plumbing and Sewer Piping.

Current edition approved May 10, 2002. Published August 2002. Originally published as C 1461-00. Last previous edition C 1461-00.

² *Annual Book of ASTM Standards*, Vol 01.03.

³ *Annual Book of ASTM Standards*, Vol 04.07.

⁴ *Annual Book of ASTM Standards*, Vol 09.01.

sleeve incorporating corrosion-resistant tension bands and a tightening mechanism. Couplings shall be fabricated without shear rings. Couplings installed without metallic shear rings shall not be installed in fire-resistive construction.

4.1.2 *Shielded*—A coupling consisting of an elastomeric or rubber sleeve incorporating a metallic corrosion-resistant shear ring and tension bands or tightening mechanism, or both.

4.1.3 *Other*—A coupling (gasket) fabricated for elastomeric compression seals.

5. Materials and Manufacture

5.1 Elastomeric materials used in the manufacturing of couplings and inserts shall comply with the requirements in accordance with Specification C 1440.

5.2 The stainless steel tension band assembly shall be 300 series stainless steel, excluding copper bearing alloys, meeting the requirements of the appropriate ASTM standard for stainless steel.

5.3 Couplings with bushings or inserts, or both, of multi-piece construction or with splices shall show no separation, peeling, or other defects when tested in accordance with Section 9.

5.4 The coupling shall be free from porosity and air pockets. Its surface shall be smooth and free from pitting, cracks, blisters, air marks, or any other imperfections that affect its performance in service. The flash extension shall not exceed 1/32 in. (0.8 mm) at any point where the presence of flash affects performance.

6. Requirements

6.1 In horizontal installations, unshielded couplings shall be supported on both sides of the coupling with suitable hangers or support necessary to support the pipe and fittings joined. The support must be located within 18 in. (457 mm) of the center of the coupling.

6.2 Couplings shall not be installed in locations where the expected internal or external temperatures are below 0°F (-18°C) or exceed 130°F (54°C).

6.3 Unshielded couplings shall not be installed in construction that has a fire rating that restricts the use of flammable materials through penetrations or plenums without additional fire-resistive protection.

7. Dimensions, Mass, and Permissible Variations

7.1 Coupling and bushing dimensions shall be compatible with the dimensions and tolerances of the specific piping material which it is designed to join.

8. Sampling, Tests, and Retests

8.1 Test specimens representative of the couplings to be used shall be randomly selected from the manufactured lot for testing.

8.2 Not less than two couplings for each size or type shall be tested, unless otherwise specified or waived by the purchaser.

8.3 Where there is a failure in the original test, the entire test shall be rerun with twice the number of samples and any failure shall be cause for rejection.

9. Test Methods

9.1 *Elastomeric Materials*—Physical properties of gaskets

shall be in accordance with specification ASTM C 1440. Many thermoplastic elastomeric gaskets are temperature-sensitive. Refer to Specification C 1440 for the allowable temperature range of materials.

9.2 Tension Band Performance:

9.2.1 *Torque Resistance*—Stainless steel tension bands shall be tested to withstand 150 % of the manufacturer's specified installation torque without visible signs of failure. The band shall be tested over a steel mandrel of the appropriate coupling diameter and torqued as required.

9.2.2 The maximum free running torque shall be 4 lbf-in. (0.45 N-m).

9.2.2.1 Stainless steel tension bands with torque resistance in excess of 100 lbf-in. shall have a maximum free running torque of 8 lbf-in.

9.2.3 Test Procedure for Free Running Torque:

9.2.3.1 With the nonstressed clamp hand-held and the slotted band fully engaged, the screw shall be rotated clockwise four revolutions with the maximum value of the torque meter recorded.

9.2.3.2 The equipment required shall be a hand-held torque meter with a 0 to 15-lbf-in. range.

9.3 Joint Assemblies Test Methods:

9.3.1 *Deflection Sealing Resistance Test*—The joint shall have sufficient flexibility to permit deflection in any direction as defined by Table 1 and shall show no visible leakage when so deflected while under an internal hydrostatic pressure of 4.3 psi (30 kPa). The ends of the test pipe shall be restrained only by an amount necessary to prevent longitudinal movement. The deflection shall be measured as the distance the free end of the one pipe has moved away from the center line of the fixed pipe. See Fig. 1.

9.3.2 *Shear Loading Resistance*—The joint shall have sufficient resistance to shear loading to meet the requirements of the following test. Two lengths of randomly selected pipe shall be joined by a coupling with the two joined lengths of pipe supported on blocks at three locations. One length of pipe shall be supported on two blocks, one near the unjoined end, and the other immediately adjacent to the joint. This length shall then be firmly restrained in position. The other length of pipe shall be supported by a single block located 36 in. (0.9 m) from the centerline of the joint. A load of 50 lbf-in. (220 N/25 mm) of nominal pipe diameter adjusted by the weight of pipe extending beyond the support times its moment arm divided by the moment arm to the test load, shall be uniformly applied over an arc of 120° and along a longitudinal length of 24 in. (0.6 m) immediately adjacent to the joint of the pipe having one support (see Fig. 2). While thus loaded, an internal hydrostatic pressure of 4.3 psi (30 KPa) shall be maintained for a period of 1 h with the temperature of water, pipe, and atmosphere within the range between 60°F and 75°F (15.5 and 23.8°C) and shall show no visible leakage.

9.4 Unrestrained Hydrostatic Joint Test:

TABLE 1 Requirements - Deflection per Foot of Pipe Length

Nominal ID, in. (mm), incl.	Offset in./linear ft (mm/linear m)
1 1/2-4	1/2 in.

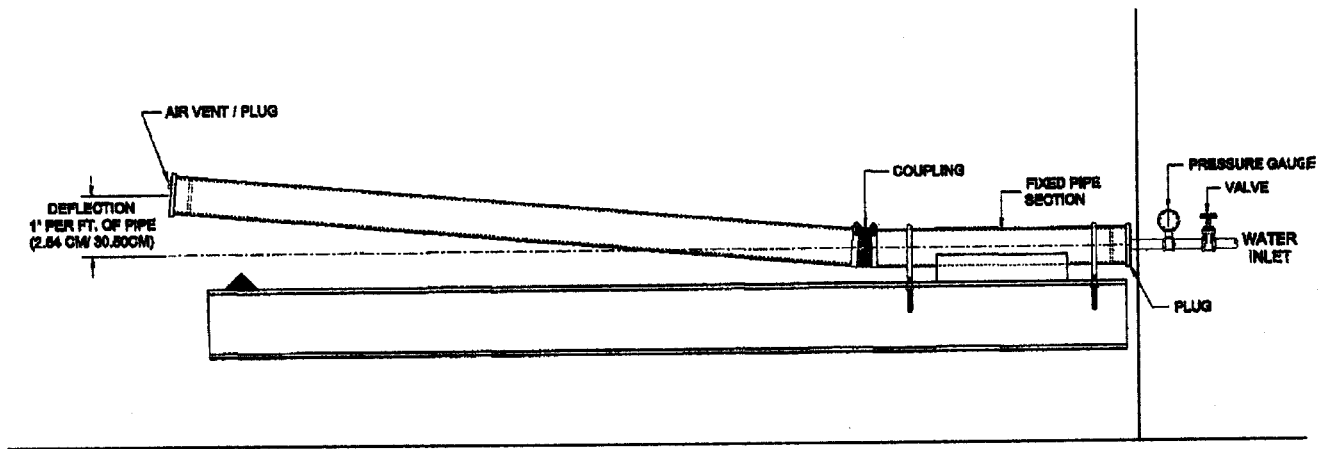

NOTE 1—Deflection (in.(mm)) = L(ft(m)) × offset (in./linear ft (mm/linear m)). See Table 2.

FIG. 1 Deflection Test (Plan View)

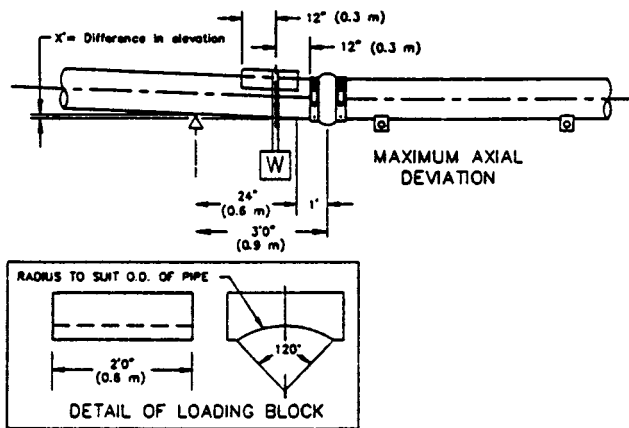

W = 59 LB. PER IN. (220 N PER 25mm)

AXIAL DEVIATION = $\frac{3X^2}{2}$

NOTE 1—For maximum axial deviation values, see Table 3.

FIG. 2 Shear Test

9.4.1 Assemble each coupling tested according to the manufacturer's instruction between two sections of machined steel pipe and conduct the unrestrained hydrostatic joint test.

9.4.2 The assembly shall consist of a maximum outside diameter pipe connected to a minimum outside diameter pipe with diameters as referenced in the appropriate pipe standards and lengths as shown in Fig. 3. Machine the plain ends of the pipe to be used for the unrestrained hydrostatic joint test to the correct diameters. Plain ends shall have 0.015 in. (0.38 mm) deep grooves machined circumferentially around them at .125 in. (2 mm) intervals down the pipe section for a distance equal to that covered by the elastomeric sleeve of the coupling being

tested. The tool used to machine the grooves shall have a 60° included angle and cut into the pipe from a perpendicular position. The surface between the grooves shall be a lathe turned surface finish of 125 RMS.

9.4.3 The plain ends of the pipe for the unrestrained hydrostatic joint test shall be uncoated, cleaned, and thoroughly dried before each assembly.

9.4.4 Test Method:

9.4.4.1 Support the pipe assemblies in a manner that does not restrain joint movement as shown in Fig. 3.

9.4.4.2 Fill the pipe assembly with water, expelling all air. Increase the hydrostatic pressure at a rate of 1 psi (6.9 kPa) every 30 s until the specified test pressure is reached. The specified test pressure shall be 20 psi (137.9 kPa) for 1 1/2 in. (38.1 mm) through 4 in. (100 mm), When the specified test pressure is reached, hold it for 10 min. Any leakage or axial joint movement of more than 0.150 in. (3.81 mm) shall mean failure.

10. Product Marking

10.1 Each coupling shall be permanently marked with the manufacturer's name and country of origin. It shall have adequate marking of such manufacturer's name if the marking readily identifies the manufacturer to the end user of the product.

10.2 The type, class, and size of pipe for which the coupling is intended shall be marked on or attached to each coupling and shall be visible after installation.

10.3 All couplings shall be marked with the designation ASTM _____ showing compliance to this standard.

1. Pressure Regulator
2. Pressure Gauge, 1 psi increments, 0-30 psi
3. Dial Indicator
4. Air Bleed Off Vent
5. Pipe
6. Coupling
7. Alignment Brackets
8. Clamp
9. Test Stand
10. 3/8" Quick Disconnect Coupling
11. 3/8" Rubber hose

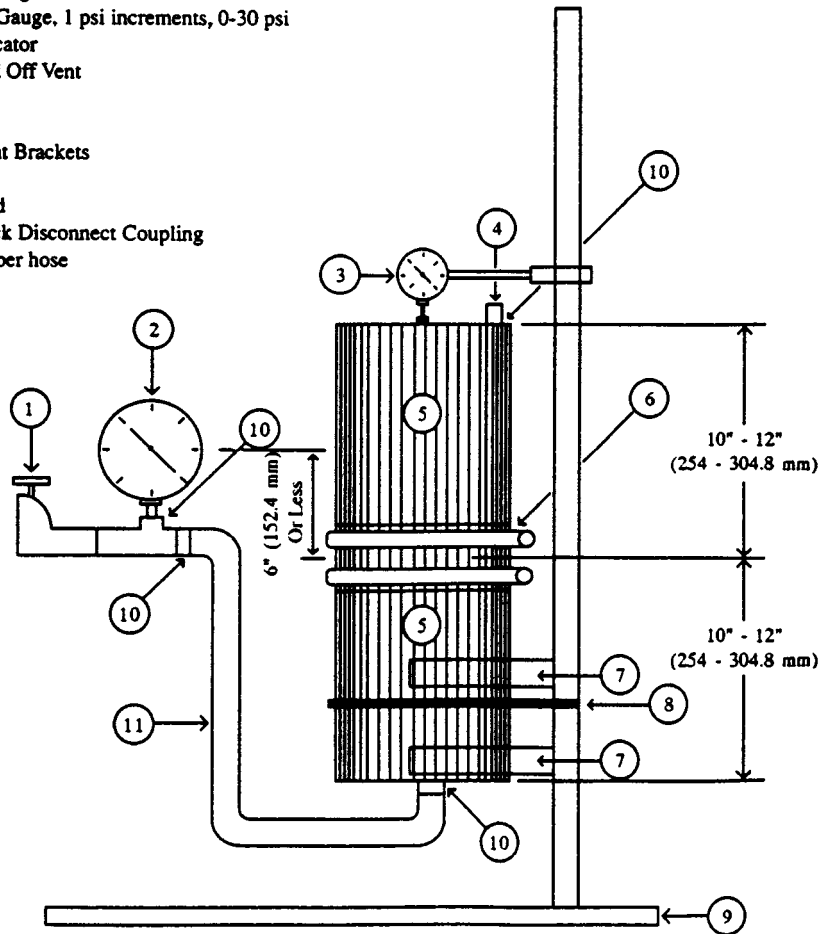

FIG. 3 Unrestrained Hydrostatic Joint Test

ASTM International takes no position respecting the validity of any patent rights asserted in connection with any item mentioned in this standard. Users of this standard are expressly advised that determination of the validity of any such patent rights, and the risk of infringement of such rights, are entirely their own responsibility.

This standard is subject to revision at any time by the responsible technical committee and must be reviewed every five years and if not revised, either reapproved or withdrawn. Your comments are invited either for revision of this standard or for additional standards and should be addressed to ASTM International Headquarters. Your comments will receive careful consideration at a meeting of the responsible technical committee, which you may attend. If you feel that your comments have not received a fair hearing you should make your views known to the ASTM Committee on Standards, at the address shown below.

This standard is copyrighted by ASTM International, 100 Barr Harbor Drive, PO Box C700, West Conshohocken, PA 19428-2959, United States. Individual reprints (single or multiple copies) of this standard may be obtained by contacting ASTM at the above address or at 610-832-9585 (phone), 610-832-9555 (fax), or service@astm.org (e-mail); or through the ASTM website (www.astm.org).