



Designation: **C 1541 – 024**

Standard Specification for Shielded Transition Couplings Using Flexible Poly Vinyl Chloride (PVC) Gaskets to Connect Dissimilar DWV Pipe and Fittings¹

This standard is issued under the fixed designation C 1541; the number immediately following the designation indicates the year of original adoption or, in the case of revision, the year of last revision. A number in parentheses indicates the year of last reapproval. A superscript epsilon (ϵ) indicates an editorial change since the last revision or reapproval.

1. Scope

1.1 This specification covers the performance of shielded transition couplings using flexible PVC gaskets to join dissimilar DWV pipe and fittings above and below ground up to and including 10-in. pipe and fittings.

1.2 The values stated in inch-pound units are to be regarded as the standard. The SI units given in parenthesis brackets are for information only.

1.3 The committee with jurisdiction over this standard is not aware of any comparable standards of any other organization.

1.4 The following precaution pertains only to the test method portion, Sections 7 and 8 of this specification. *This standard does not purport to address all of the safety concerns, if any, associated with its use. It is the responsibility of the user of this standard to establish appropriate safety and health practices and determine the applicability of regulatory requirements prior to use.*

¹ This specification is under the jurisdiction of ASTM Committee C24 on Building Seals and Sealants and is the direct responsibility of Subcommittee C24.75 on Gaskets and Couplings for Plumbing and Sewer Piping.

Current edition approved ~~July 10, 2002~~; February 1, 2004. Published ~~September~~ March 2004. Originally approved in 2002. Last previous edition approved in 2002 as C 1541 - 02.

2. Referenced Documents

2.1 ASTM Standards:²

A 493 Specification for Stainless Steel Wire and Wire Rods for Cold Heading and Cold Forging

C 717 Terminology of Building Seals and Sealants

D 5926 Specification for Poly Vinyl Chloride (PVC) Gaskets for Drain Waste and Vent (DWV), Sewer, Sanitary, and Storm Plumbing Systems

3. Terminology

3.1 Definitions:

3.1.1 Definitions of the following terms used in this specification are found in Terminology C 717.

3.2 Definitions of Terms Specific to This Standard:

3.2.1 *center stop, n*—an integral part of the gasket centered on the axial length of the gasket intended to limit the insertion depth of the pipe to be coupled.

3.2.2 *clamp assembly, n*—that portion of the coupling excluding the gasket.

3.2.3 *coupling, n*—the complete assembly.

3.2.4 *dissimilar DWV pipe and fittings, n*— pipe and fittings made of different materials or different outside diameters, or both.

3.2.5 *fitting, n*—parts of a pipeline other than straight pipes, valves, or couplings.

3.2.6 *gasket, n*—the elastomeric portion of the coupling.

3.2.7 *joint, n*—the point of assembly consisting of the coupling and the joined pipes or fittings, or both.

3.2.8 *shield, n*—an external metallic protective device designed to protect the sealing gasket from external elements that could cause failure of the sealing assembly.

4. Materials and Manufacture

4.1 Physical properties of Flexible PVC (Poly Vinyl Chloride) gaskets shall comply with Specification D 5926. The gaskets shall be permitted to be spliced or molded.

4.2 All steel parts shall be 300 series stainless steel meeting the requirements of Specification A 493 excluding copper bearing alloys.

5. Requirements

5.1 Couplings shall be supported with suitable hangers or support necessary to support the pipe, fitting, and contents. The support must be located within 18 in. of the center of the coupling.

5.2 The coupling shall not be installed in a location where the expected internal or external temperatures are below -30°F (-34°C) [-34°C] or exceed 130°F (54°C) [54°C].

5.3 Couplings shall not be installed in construction that has a fire rating that restricts the use of flammable materials through penetrations or plenums without additional fire-resistive protection.

6. Elastomeric Gasket Requirements

6.1 The elastomeric gasket shall consist of one piece conforming to the physical requirements of 4.1.

6.2 The elastomeric gasket shall have an inside center stop-ring spaced an equal distance from the ends to serve as a stop between the pipe/fitting ends. The center stop ring shall not create an enlargement chamber or recess with a ledge, shoulder or reduction of pipe area or offer an obstruction to flow. A gasket without an inside center stop shall be permitted in tubular transition ~~applications, where telescoping of pipe is necessary, applications.~~

6.3 The elastomeric gasket shall be free from imperfections and porosity that affects its use and serviceability.

7. Clamp Assembly Requirements

7.1 Stainless steel tension bands shall be tested to withstand 125 % of the manufacturer's installation torque or a minimum of

² For referenced ASTM standards, visit the ASTM website, www.astm.org, or contact ASTM Customer Service at service@astm.org. For Annual Book of ASTM Standards, Vol 01.03, volume information, refer to the standard's Document Summary page on the ASTM website.

TABLE 1 Unrestrained Hydrostatic Joint Test

Pipe Size	Test Pressure
1½ to 5 in. (38 to 76 mm)	20 psi (138 kPa)
1½ to 5 in. [38 to 76 mm]	20 psi [138 kPa]
6 in. (152.4 mm)	18 psi (124 kPa)
6 in. [152.4 mm]	18 psi [124 kPa]
8 in. (203.2 mm)	10 psi (69 kPa)
8 in. [203.2 mm]	10 psi [69 kPa]
10 in. (254 mm)	6 psi (41.4 kPa)
10 in. [254 mm]	6 psi [41.4 kPa]

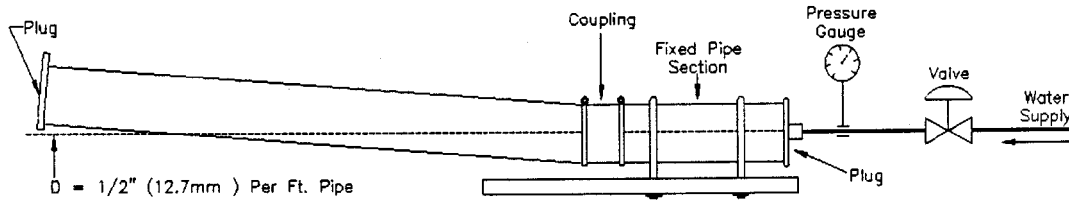

FIG. 1 Deflection Test

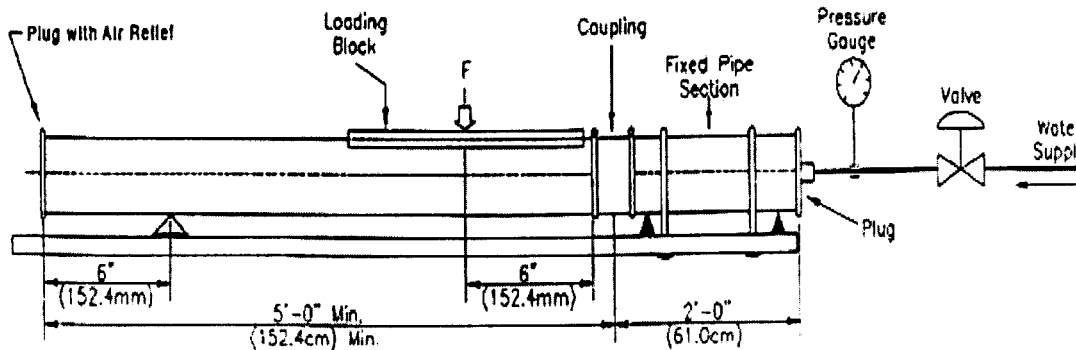

FIG. 2 Shear Testing Apparatus

60 in.-lbf of applied torque whichever is greater without visible signs of failure. The band shall be tested over a steel mandrel of the appropriate coupling diameter and torque as required.

7.2 Clamp assembly screws or bolts shall not have screwdriver slots.

8. Coupling Requirements and Test Methods

8.1 Assemble each coupling tested according to in accordance with the manufacturer's instructions between two sections of randomly selected pipe manufactured to appropriate standards for the type of pipe the couplings are expected to join. The pipe section will not exceed a length of 20 ft (6.1 m). [6.1 m]. Conduct the following tests:

8.2 *Deflection Test*—Each coupling tested shall be mounted between two pieces of pipe as provided in 8.1. The out bound ends of the pipe shall be closed with test plugs. The assembly shall be filled with water, all air expelled, and hydrostatically pressurized to 4.3 psi (29.6 kPa) for the duration of the test. One pipe shall be rigidly supported and while the assembly is under pressure, the opposite end of the other pipe shall be raised 1/2 in. (12.7 mm) per linear foot of pipe. The pressure shall be maintained for 15 min and leakage shall not be permitted. A test apparatus such as the one shown in Fig. 1 is suggested.

8.3 *Shear Test*—The assembly shall be filled with water, all air expelled, and hydrostatically pressurized to 4.3 psi (29.6 kPa) for the duration of the test. Two joined lengths of pipe selected as provided in 8.1 shall be supported on blocks at three locations. One length shall be supported on two blocks, one near the uncoupled end and the other immediately adjacent to the coupling. This length shall be firmly restrained in position (refer to Fig. 2). The other coupled length shall be supported by a single block 6 in. (152.4 mm) from the end of the pipe. A load of 50 pounds (22.7 kg) lb [22.7 kg] per inch of nominal diameter shall be applied at a point 6 in. (152.4 mm) from the edge of the coupling upon a 12 in. (304.8 mm) length of 3 by 3 (76.2 mm by 76.2 mm) angle iron or load distributing pad located on the top of the pipe immediately adjacent to the coupling of the pipe having one support only. When testing reducing couplings the load shall be applied to the reduced size. Under this loading there shall be no visible leakage or displacement of more than 3/8 in. (9.5 mm) [9.5 mm] from true alignment when an internal pressure equivalent to a 10 ft (3 m) [3 m] head of water 4.3 psi (29.6 kPa) is applied. The load and internal pressure shall be maintained for 15 min and leakage shall not be permitted.

8.4 Unrestrained Hydrostatic Joint Test:

8.4.1 Each coupling tested shall be assembled according to in accordance with the manufacturer's instructions between two sections of machined steel pipe and conduct the unrestrained hydrostatic joint test.

8.4.2 The plain ends of the pipe to be used shall be machined to the correct nominal outside diameter of the types of pipe for which the coupling is intended to join. Plain ends shall have 0.015 in. (2 mm) [2 mm] deep grooves machined circumferentially around them at 0.125 in. (3.2 mm) [3.2 mm] intervals down the pipe section for a distance equal to that covered by the elastomeric sleeve. The tool used to machine the grooves shall have a 60° included angle and shall cut into the pipe from a perpendicular position. The surface between the grooves shall be a lathe turned surface of 125 RMS. The plain ends of the pipe are to be uncoated and shall be cleaned with acetone and thoroughly dried before each assembly.

8.4.3 Fill the pipe assembly with water, expelling all air and increase the hydrostatic pressure at a rate of 1 psi-[6.9 kPa] every 30 s to the target test pressure shown in Table 1. When the target pressure is reached, it shall be held for 10 min. Any leakage or axial joint movement of more than 0.150 in.-(3.8 mm) [3.8 mm] shall mean failure.

8.4.4 The pipe assemblies are to be supported in a manner that does not restrain joint movement as shown in Fig. 3.

9. Markings and Identification

9.1 Each gasket shall be permanently marked with the manufacturer’s name or US registered trademark, country of origin, pipe size for which it is designed, and the designation Specification D 5926.

9.2 Each coupling shall be labeled as to the size(s), material(s), class for which it is intended, operating temperature range, and the designation ASTM showing compliance to this standard. The marking shall be visible after installation.

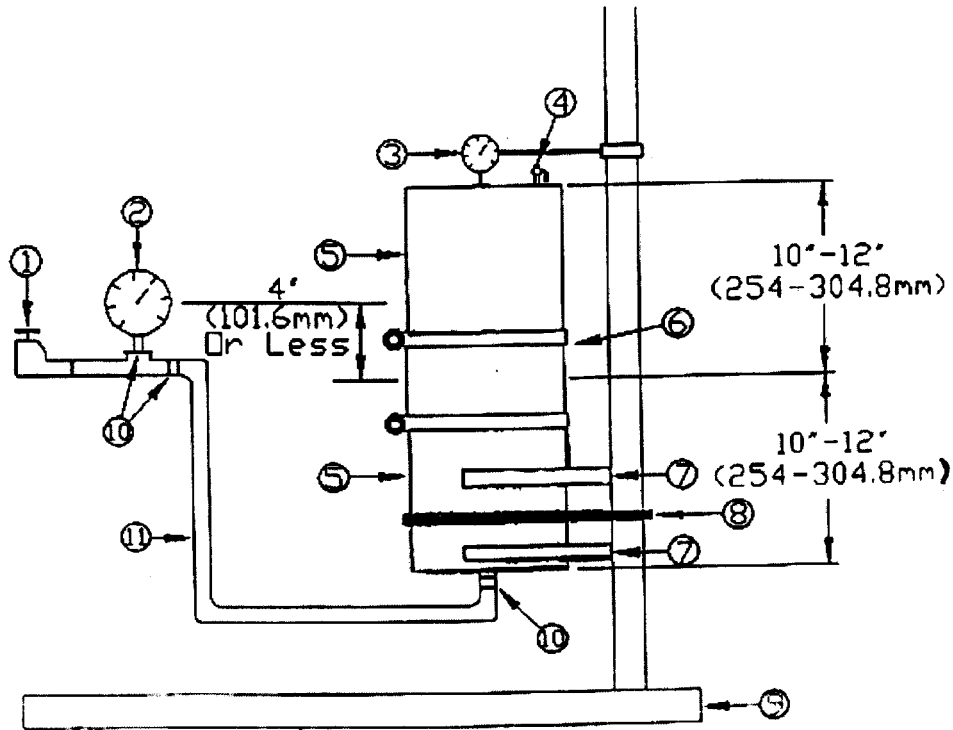

- 1. Pressure Regulator
- 2. Pressure Gauge, 1-PSI increments, 0-30 PSI
- 3. Dial indicator
- 4. Air Bleed Off Vent
- 5. Pipe
- 6. Coupling
- 7. Alignment Brackets
- 8. Clamp
- 9. Test Stand
- 10. 3/8" Quick Disconnect Coupling
- 11. 3/8" Rubber Hose

FIG. 3 Unrestrained Hydrostatic Joint Testing Apparatus

ASTM International takes no position respecting the validity of any patent rights asserted in connection with any item mentioned in this standard. Users of this standard are expressly advised that determination of the validity of any such patent rights, and the risk of infringement of such rights, are entirely their own responsibility.

This standard is subject to revision at any time by the responsible technical committee and must be reviewed every five years and if not revised, either reapproved or withdrawn. Your comments are invited either for revision of this standard or for additional standards and should be addressed to ASTM International Headquarters. Your comments will receive careful consideration at a meeting of the responsible technical committee, which you may attend. If you feel that your comments have not received a fair hearing you should make your views known to the ASTM Committee on Standards, at the address shown below.

This standard is copyrighted by ASTM International, 100 Barr Harbor Drive, PO Box C700, West Conshohocken, PA 19428-2959, United States. Individual reprints (single or multiple copies) of this standard may be obtained by contacting ASTM at the above address or at 610-832-9585 (phone), 610-832-9555 (fax), or service@astm.org (e-mail); or through the ASTM website (www.astm.org).