



## Standard Specification for Manhole Cover Assembly, Bolted, Semi-Flush, Oiltight and Watertight, Hinged<sup>1</sup>

This standard is issued under the fixed designation F 1144; the number immediately following the designation indicates the year of original adoption or, in the case of revision, the year of last revision. A number in parentheses indicates the year of last reapproval. A superscript epsilon ( $\epsilon$ ) indicates an editorial change since the last revision or reapproval.

### 1. Scope

1.1 This specification provides design and construction criteria for a semi-flush, oiltight and watertight bolted hinged manhole cover assembly.

1.2 The manhole cover assemblies depicted on this specification are for use in decks or bulkheads requiring oiltight and watertight covers that are not required to be completely flush. Manhole cover assemblies shall be complete with covers, mounting rings, gaskets, studs, washers, hinge assemblies, and nuts.

1.3 Handles, if required, shall be as specified in the ordering information.

1.4 Values stated in inch-pound units are to be regarded as standard.

1.5 This standard is not applicable to certain hazardous cargos. (See 46CFR 153.254 and 46CFR 154.340.)

1.6 This specification provides design and construction for manhole cover assemblies subjected to lateral pressures such as resulting from vehicle loads or hydrostatic pressures. Where manhole cover assemblies are subjected to primary or cyclic loads, other reinforcement or construction criteria may be necessary to integrate the manhole assembly with the required structural reinforcement for openings in decks or bulkheads. Design of the manhole cover assembly for primary or cyclic loads is beyond the scope of this specification.

### 2. Referenced Documents

#### 2.1 ASTM Standards:

- A 36/A 36M Specification for Structural Steel<sup>2</sup>
- A 131/A 131M Specification for Structural Steel for Ships<sup>2</sup>
- A 153/A 153M Specification for Zinc Coating (Hot Dip) on Iron and Steel Hardware<sup>3</sup>
- A 575 Specification for Steel Bars, Carbon, Merchant Quality, M-Grades<sup>4</sup>

<sup>1</sup> This specification is under the jurisdiction of ASTM Committee F25 on Ships and Marine Technology and is the direct responsibility of Subcommittee F25.03 on Outfitting.

Current edition approved Oct. 10, 1998. Published December 1998. Originally published as F 1144 – 88. Last previous edition F 1144 – 90.

<sup>2</sup> Annual Book of ASTM Standards, Vol 01.04.

<sup>3</sup> Annual Book of ASTM Standards, Vol 01.06.

<sup>4</sup> Annual Book of ASTM Standards, Vol 01.05.

B 36/B 36M Specification for Brass Plate, Sheet, Strip, and Rolled Bar<sup>5</sup>

D 2000 Classification System for Rubber Products in Automotive Applications<sup>6</sup>

F 783 Specification for Staple, Handgrab, Handle, and Stirrup Rung<sup>7</sup>

#### 2.2 ANSI Standards:

B1.1 Unified Inch Screw Threads<sup>8</sup>

Y14.5M Dimensioning and Tolerancing<sup>8</sup>

B18.2.1 Square and Hex Bolts and Screws, Inch Series<sup>8</sup>

#### 2.3 ABS Standard:

Rules for Building and Classing Steel Vessels<sup>9</sup>

#### 2.4 Steel Structures Painting Council Standard:

SP-10 Surface Preparation Specification No. 10<sup>10</sup>

#### 2.5 Code of Federal Regulations Standard:

CFR 46 Code of Federal Regulations<sup>11</sup>

### 3. Terminology

#### 3.1 Definitions:

3.1.1 *manhole*—accessway located in a tank structure.

3.1.2 *semi-flush*—refers to the placement of the hinged plate over the ringed opening (without coaming).

### 4. Classification

4.1 Type I—15- by 23-in. (381- by 584-mm) size of access opening

4.2 Type II—18- by 24-in. (457- by 610-mm) size of access opening

4.3 Grade 1— $\frac{1}{4}$ -in. (6.4-mm) thick cover plate

4.4 Grade 2— $\frac{3}{8}$ -in. (9.5-mm) thick cover plate

4.5 Grade 3— $\frac{1}{2}$ -in. (12.7-mm) thick cover plate

4.6 *Class A Manhole Cover Assemblies*— Shall be abrasive blasted to near white metal in accordance with SSPC SP-10

<sup>5</sup> Annual Book of ASTM Standards, Vol 02.01.

<sup>6</sup> Annual Book of ASTM Standards, Vol 09.02.

<sup>7</sup> Annual Book of ASTM Standards, Vol 01.07.

<sup>8</sup> Available from American National Standards Institute, 11 W. 42nd St., 13th Floor, New York, NY 10036.

<sup>9</sup> Available from American Bureau of Shipping, Corporate Publications Dept., Two World Trade Center, 106th Floor, New York, NY 10048.

<sup>10</sup> Available from Steel Structures Painting Council, 4400 Fifth Ave., Pittsburgh, PA 15213.

<sup>11</sup> Available from Superintendent of Documents, Government Printing Office, Washington, DC 20402.

and a commercial marine quality nonhazardous corrosion-inhibiting and oil-resistant primer coating be applied for protection for a period of one year during shipping and in shipyard handling.

4.7 *Class B Manhole Cover Assemblies*— Shall be galvanized in accordance with Specification A 153.

## 5. Ordering Information

5.1 The purchasers ordering information shall include the following:

5.1.1 ASTM designation and date.

5.1.2 Type (see 4.1 and 4.2).

5.1.3 Grade (see 4.3, 4.4, and 4.5).

5.1.4 Class see (4.6 and 4.7).

5.1.5 Quantity.

5.1.6 Remarks—Handles (are/are not) required.

5.1.7 Approval—Classification society approval (is/is not) required.

5.1.8 Gasket, if other than specified (see 6.8).

## 6. Materials and Manufacture

6.1 Plate for the cover, ring, hinge pad and hinge blade shall be in accordance with Specification A 36/A 36M or A 131/A 131M steel.

6.2 Round bar for the handle shall be in accordance with Specification F 783, Type A.

6.3 Round bar for the hinge pin shall be of Specification A 575 steel.

6.4 Welded studs shall be  $\frac{3}{4}$  in. (19.1 mm)—10 UNC-2A by  $1\frac{3}{4}$  in. (44.5 mm) long and manufactured of ordinary steel to commercial standards. Threads shall be the coarse thread series in accordance with the latest issue of ANSI B1.1.

6.5 Washers shall be ANSI B18.2.1 Type A,  $\frac{3}{4}$ -in. (19.1-mm) washer, 2-in. (50.8-mm) by 0.148-in. (3.8-mm) thick standard flat manufactured of yellow brass, in accordance with Specification B 36/B 36M.

6.6 Heavy hex nuts shall be  $\frac{3}{4}$  in. (19.1 mm)—10 UNC-2B and manufactured of yellow brass, in accordance with Specification B 36/B 36M. Threads in nuts shall conform to the dimensions for coarse threads with tolerances prescribed in accordance with ANSI B1.1. The nuts shall conform to dimensions prescribed in accordance with ANSI B18.2.1.

6.7 Cotter pin to be in accordance with Specification B 36/B 36M yellow brass,  $\frac{1}{8}$  by  $1\frac{3}{4}$  in. (3.2 by 44.5 mm) long.

6.8 Unless otherwise specified in ordering information, gasket to be rubber,  $\frac{3}{16}$  in. (4.8 mm) thick,  $50 \pm 5$  durometers per Classification D 2000 5BC507 A14 E034. For manhole cover assemblies for government application, see Annex A2 for type of gasket.

6.9 Welding to conform to the latest issue of American Bureau of Shipping Rules or other such classification society rules as may be applicable.

6.10 Details of bolted manholes are shown in Fig. 1.

## 7. Dimensions

7.1 Dimensions of manhole shall be as indicated in Table 1.

7.2 For plating up to and including  $\frac{1}{4}$ -in. (6.4-mm) thickness, use cover plate of  $\frac{1}{4}$ -in. (6.4-mm) thickness. Plating over  $\frac{1}{4}$ -in. (6.4-mm) up to and including  $\frac{3}{8}$ -in. (9.5-mm) thickness;

use cover plate of  $\frac{3}{8}$ -in. (9.5-mm) thickness. Plating over  $\frac{3}{8}$ -in. (9.5-mm) thickness, use cover plate of  $\frac{1}{2}$ -in. (12.7-mm) thickness.

## 8. Finish

8.1 Items produced under this specification shall be free of splinters, sharp edges, burrs, projections, and weld spatters.

8.2 Unless otherwise specified in ordering data, items shall, after fabrication, have a Class A finish.

## 9. Sampling

9.1 For orders for one or two manhole cover assemblies, each manhole assembly shall be inspected.

9.2 For orders for three to ten manhole cover assemblies, two manhole cover assemblies shall be selected at random. If any one of them fails to meet requirements, then all manhole cover assemblies in the order shall be inspected.

9.3 For orders for more than ten manhole cover assemblies, they shall be separated into groups of ten (or fraction thereof) for sampling purposes.

## 10. Inspection and Testing

10.1 *Responsibility*—Unless otherwise specified in the order, the manufacturer is responsible for the performance of all inspection and testing specified herein. The manufacturer may use his own facilities or any commercial facility acceptable to the purchaser. The purchaser reserves the right to perform any of the inspections and tests set forth where such are deemed necessary to assure that supplies conform to prescribed requirements. Nonconforming manhole cover assemblies shall not be offered for delivery.

10.2 *Inspection*—The dimensions of the manhole cover assembly and its components shall be checked to ensure that they are within specified tolerances.

10.3 *Test Methods*—Each manhole cover assembly shall be designed to the pressure listed in Table 1 and tested to a pressure equal to 1.5 times the design pressure. The test pressure shall be held for a minimum of 5 min. There shall be no visible sign of leakage, permanent deformation, or other indications of structural failure of the manhole cover assembly.

10.3.1 Before delivery, manhole cover assemblies shall be certified as to their watertight and oiltight integrity. Groups of manhole cover assemblies whose representative samples pass the tightness test shall be certified for watertight and oiltight integrity to their design pressure.

## 11. Product Marking

11.1 Each manhole cover assembly shall be marked with the purchase order number, item number from purchase order, ASTM designation number, type, grade, class, and manufacturers' name. Marking may be by paint, stencil, or weather-proof tag.

## 12. Packaging and Package Marking

12.1 Unless otherwise specified, packaging shall conform to manufacturer's normal commercial practice, and in such a manner that will ensure acceptance by common carrier and afford protection against physical damage during shipment. Shipping containers shall conform to carrier regulations as applicable to the mode of transportation.

**ASTM F 1144 – 98**

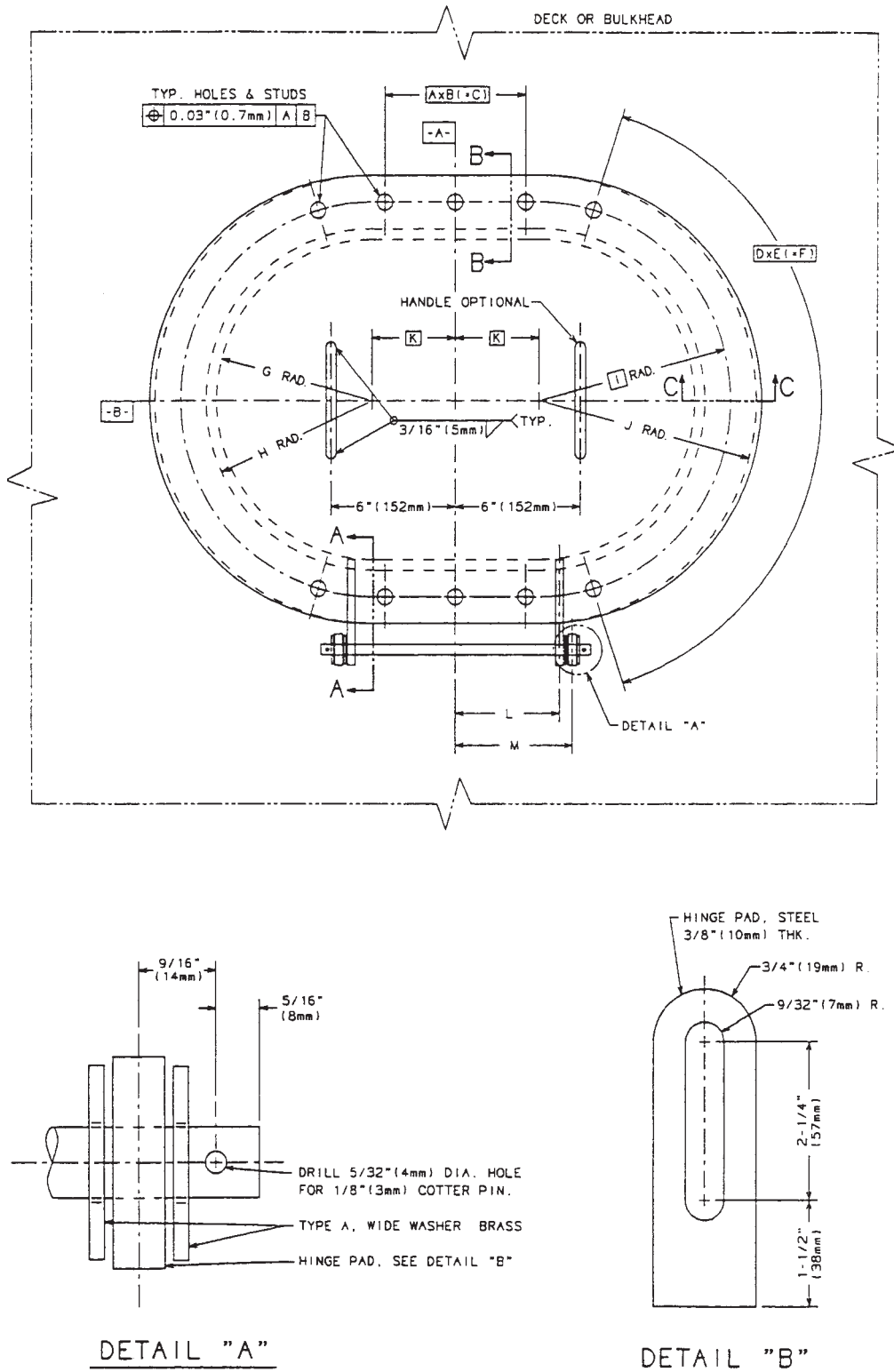

NOTE 1—1 in. = 25.4 mm.

**FIG. 1 Manhole Cover Assembly, Bolted, Hinged, Semi-Flush, Oiltight and Watertight.**

12.2 For government procurements for long-term storage or overseas shipment, the requirements of Annex A1 apply. In such case, the required level of packaging shall be specified.

**ASTM F 1144 – 98**

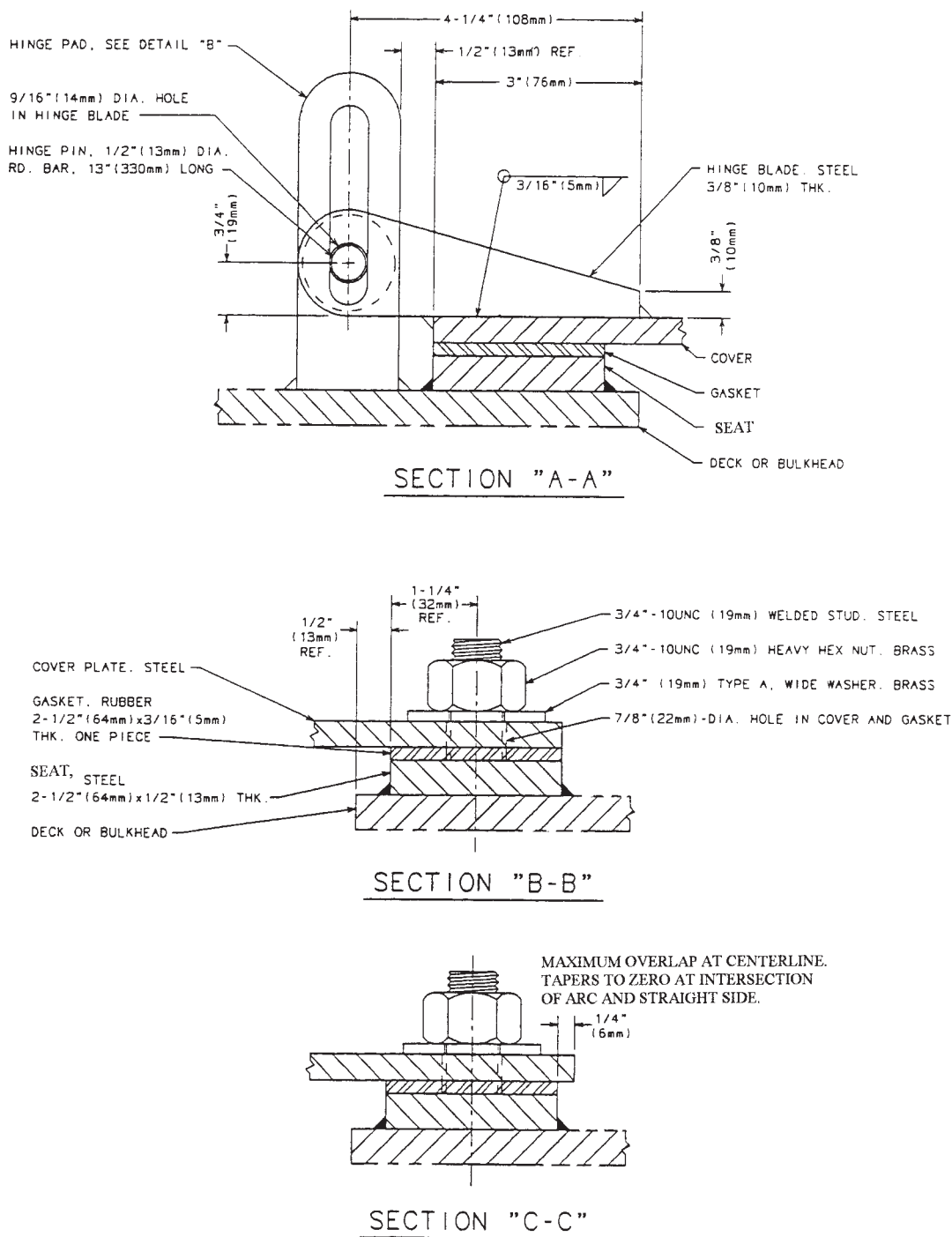

NOTE 1—1 in. = 25.4 mm.

**FIG. 1 Manhole Cover Assembly, Bolted, Hinged, Semi-Flush, Oiltight and Watertight. (continued)**

**13. Keywords**

13.1 bulkhead; decks; manhole cover; manhole cover as-

sembly; marine technology; ships

**NOTICE: This standard has either been superseded and replaced by a new version or discontinued.  
Contact ASTM International (www.astm.org) for the latest information.**

**TABLE 1 Dimensions for Bolted, Hinged, Semi-Flush, Oiltight and Watertight Manhole Cover Assembly<sup>A</sup>**

NOTE 1—1 in. = 25.4 mm.

Type	Grade	Plate Thickness		Deck Cut Overall Size		A	B		C		D	E, °	F, °	G		H		I		J		K	
		in.	(mm)	in.	(mm)		in.	(mm)	in.	(mm)				in.	(mm)	in.	(mm)	in.	(mm)	in.	(mm)	in.	(mm)
I	1	¼	(6.5)	15 × 23	(381 × 584)	2	3⅝	(86)	6¾	(171)	7	21	147	7½	(191)	8	(203)	9¼	(235)	10½	(267)	4	(102)
I	2	⅜	(9.5)	15 × 23	(381 × 584)	2	3⅝	(86)	6¾	(171)	7	21	147	7½	(191)	8	(203)	9¼	(235)	10½	(267)	4	(102)
I	3	½	(12.5)	15 × 23	(381 × 584)	2	3⅝	(86)	6¾	(171)	7	21	147	7½	(191)	8	(203)	9¼	(235)	10½	(267)	4	(102)
II	1	¼	(6.5)	18 × 24	(457 × 610)	2	3¼	(83)	6½	(165)	8	18	144	9	(229)	9½	(241)	10¾	(273)	12	(305)	3	(76)
II	2	⅜	(9.5)	18 × 24	(457 × 610)	2	3¼	(83)	6½	(165)	8	18	144	9	(229)	9½	(241)	10¾	(273)	12	(305)	3	(76)
II	3	½	(12.5)	18 × 24	(457 × 610)	2	3¼	(83)	6½	(165)	8	18	144	9	(229)	9½	(241)	10¾	(273)	12	(305)	3	(76)

L		M		Stud Quantity	Design Pressure		Weight	
in.	(mm)	in.	(mm)		psi	(kPa)	lb	(kg)
5	(127)	5⅝	(143)	22	12.0	82.7	90	41
5	(127)	5⅝	(143)	22	27.0	186.2	112	51
5	(127)	5⅝	(143)	22	47.9	330.2	134	61
5	(127)	5⅝	(143)	24	8.9	62.1	100	45
5	(127)	5⅝	(143)	24	20.0	137.9	126	57
5	(127)	5⅝	(143)	24	35.6	245.5	152	69

<sup>A</sup> The letters in the headings designate the following:

- A = number of spaces on straight side,
- B = bolt spacing (straight side),
- C = total span,
- D = number of spaces on arc side,
- E = bolt spacing (arc side),
- F = arc span,
- G = accessway inner radius,
- H = seat and gasket inner radius,
- I = bolt circle arc radius,
- J = seat and gasket outer radius,
- K = offset for radii from center of accessway and cover,
- L = distance from centerline of cover to centerline of hinge blade, and
- M = distance from centerline of cover to centerline of hinge pad.



**ANNEXES**

**(Mandatory Information)**

**A1. PACKING FOR DoD PROCUREMENTS**

**A1.1 Referenced Documents**

*A1.1.1 Federal Specifications:*

- PPP-B-576—Box, wood, cleated, veneer, paper overlaid.
- PPP-B-585—Boxes, wood, wirebound.
- PPP-B-591—Boxes, fiberboard, wood-cleated.
- PPP-B-601—Boxes, wood, cleated-plywood.
- PPP-B-621—Boxes, wood, nailed and lock corner.
- PPP-B-636—Box, fiberboard.
- PPP-B-640—Boxes, fiberboard, corrugated, triple, wall.

*A1.1.2 Military Standard:*

MIL-STD-129—Marking for shipment and storage

*A1.1.3 Official Classification Committee Rules:*

Uniform Freight Classification Rules

PPP-B-636	Weather resistant
PPP-B-640	Class 2

Boxes shall be closed and banded in accordance with the applicable box specification.

*A1.3.3 Level B*

Manhole cover assemblies shall be packed in boxes conforming to any of the following specifications at the option of the manufacturer:

Specification	Type or Class
PPP-B-576	Domestic
PPP-B-585	Class 1 or 2
PPP-B-591	Domestic
PPP-B-601	Domestic
PPP-B-621	Class 1
PPP-B-636	Domestic
PPP-B-640	Class 1

**A1.2 Preservation**

A1.2.1 None required.

**A1.3 Packing**

A1.3.1 The manhole cover assembly shall be cushioned, blocked, or braced within the container in a manner to prohibit movement. Unless otherwise specified in the order, one manhole cover assembly shall be packed per container. When more than one manhole cover assembly is required to be packed in each container, the gross mass of the wood or wood-cleated boxes shall not exceed approximately 100 kg.

*A1.3.2 Level A*

Manhole cover assembly shall be packed in containers conforming to any one of the following specifications at the option of the manufacturer:

Specification	Type or Class
PPP-B-576	Overseas
PPP-B-585	Class 3
PPP-B-591	Overseas
PPP-B-601	Overseas
PPP-B-621	Class 2

Box closures shall be as specified in the applicable box specification. The gross mass of wood or wood-cleated boxes shall not exceed 100 kg.

*A1.3.4 Level C*

Packing shall be accomplished in a manner that will ensure acceptance by common carrier, at lowest rate, and will afford protection against physical or mechanical damage during direct shipment from the supply source to the using activity for early installation. The shipping containers or method of packing shall conform to the uniform freight classification rules and regulations or other carrier regulations as applicable to the mode of transportation and may conform to the manufacturer's commercial practice.

**A1.4 Marking**

A1.4.1 In addition to any special marking required by the order, shipment shall be marked in accordance with MIL-STD-129.

**(Mandatory Information)**

**A2. DoD MANHOLE COVER ASSEMBLY SPECIAL APPLICATION**

**A2.1 Referenced Documents (for this annex only)**

*A2.1.1 Military Standards:*

MIL-C-6183 Cork and Rubber Composition Sheet for Aromatic Fuel and Oil Resistant Gaskets<sup>12</sup>

MIL-G-1149 Gasket Materials, Synthetic Rubber 50 and 65 Durometer Hardness<sup>12</sup>

MIL-R-900 Rubber Gasket Material 45 Durometer Hardness<sup>12</sup>

MIL-R-83248 Rubber Fluorocarbon Elastomer, High Temperature, Fluid and Compression Set Resistant<sup>12</sup>

<sup>12</sup> Available from Standardization Documents, Order Desk, Bldg. 4, Section D, 700 Robbins Ave., Philadelphia, PA 19111-5094, Attn: NPODS.



A2.2 Gasket materials used in DoD manhole cover assemblies shall be as follows:

Manhole Cover  
Assembly Service:

Required Gasket  
Material:

Manhole Cover  
Assembly Service:  
Hydraulic machinery  
spaces using phos-  
phate ester-based  
hydraulic fluid

Required Gasket  
Material:  
MIL-R-83248

General service  
Fresh water

MIL-R-900  
MIL-G-1149,  
Class 2

A2.2 DoD manhole covers shall be Class B.

Oil, gasoline,  
saltwater

MIL-C-6183,  
Class 1

*ASTM International takes no position respecting the validity of any patent rights asserted in connection with any item mentioned in this standard. Users of this standard are expressly advised that determination of the validity of any such patent rights, and the risk of infringement of such rights, are entirely their own responsibility.*

*This standard is subject to revision at any time by the responsible technical committee and must be reviewed every five years and if not revised, either reapproved or withdrawn. Your comments are invited either for revision of this standard or for additional standards and should be addressed to ASTM International Headquarters. Your comments will receive careful consideration at a meeting of the responsible technical committee, which you may attend. If you feel that your comments have not received a fair hearing you should make your views known to the ASTM Committee on Standards, at the address shown below.*

*This standard is copyrighted by ASTM International, 100 Barr Harbor Drive, PO Box C700, West Conshohocken, PA 19428-2959, United States. Individual reprints (single or multiple copies) of this standard may be obtained by contacting ASTM at the above address or at 610-832-9585 (phone), 610-832-9555 (fax), or service@astm.org (e-mail); or through the ASTM website (www.astm.org).*