



## Standard Practice for Installation Procedures for Fitting Chocks to Marine Machinery Foundations<sup>1</sup>

This standard is issued under the fixed designation F 1309; the number immediately following the designation indicates the year of original adoption or, in the case of revision, the year of last revision. A number in parentheses indicates the year of last reapproval. A superscript epsilon ( $\epsilon$ ) indicates an editorial change since the last revision or reapproval.

### 1. Scope

1.1 This practice covers the acceptable methods of fitting chocks to marine machinery foundations.

1.2 The values stated in SI units shall be regarded as standard. The values in parentheses are for information only.

1.3 *This standard does not purport to address the safety concerns associated with its use. It is the responsibility of the user of this standard to establish appropriate safety and health practices and determine the applicability of regulatory limitations prior to use.*

### 2. Referenced Documents

#### 2.1 ASTM Standards:

A 370 Test Methods and Definitions for Mechanical Testing of Steel Products<sup>2</sup>

D 638 Test Method for Tensile Properties of Plastics<sup>3</sup>

D 648 Test Method for Deflection Temperature of Plastics Under Flexural Load in the Edge-Wise Position<sup>3</sup>

D 695 Test Method for Compressive Properties of Rigid Plastics<sup>3</sup>

#### 2.2 Other Documents:

American Bureau of Shipping Rules for Building and Classing Steel Vessels<sup>4</sup>

American Welding Society Publication, AWS D1.1 Structural Welding Code<sup>5</sup>

### 3. Significance and Use

3.1 This practice provides the three principal methods of fitting chocks to marine machinery foundations to ensure that the machinery is free of vibration and perfectly aligned after installation.

3.1.1 The three principal methods of installing chocks described herein are as follows:

3.1.1.1 *Type A*—Epoxy-based resin, nonshrinking Chock-fast Orange PR 610 TCF by Philadelphia Resin Corp., or equal, and

3.1.1.2 *Type B*—Two-piece wedge chocks.

3.1.1.3 *Type C*—Solid, one-piece fitted chocks.

### 4. Procedure

4.1 *General Requirements for Types A, B, and C Chocking Systems:*

#### 4.1.1 Machining:

4.1.1.1 Type A chocks, machinery bedplates, foundation plates, and bolts do not require finish machining if the chocks are not designed to be removed. Unless specified otherwise, Types B and C chock, bolts/studs, machinery bedplate, foundation plates, and fitted holes need to be finished machined and fitted.

4.1.1.2 Surfaces in way of the chock areas on the machinery bedplate and the foundation plate may be machined before installation or while the ship is not waterborne, or both.

4.1.1.3 Unless otherwise specified, all finished surfaces shall be finished to a maximum of 0.003-mm roughness height average (RHA).

4.1.1.4 Finished areas on the machinery bedplate and the foundation plate in way of the chocks shall be sufficiently greater in size than the chock to prevent interference from the unfinished area with the chock during installation.

4.1.1.5 Spotface hole edge radius shall be such that there will not be any interference between it and the bolt head-to-shank radius. The spotface area shall be sufficiently greater in area than that of the bolt head or nut so as not to cause any interference when tightening or with the tooling used. The spotface surfaces shall be perpendicular to the finished fitted hole centerline.

#### 4.1.2 Installation:

4.1.2.1 The ship must be waterborne and fairly well completed before final alignment is accomplished. Ship shall be trimmed as close to the even keel position as practicable. The same trim position shall be maintained throughout the alignment procedure. No heavyweight shall be moved, loaded, or unloaded during alignment; ramps for Ro-Ros shall not be lowered or hoisted.

4.1.2.2 Final machining of the fitted or bearing areas of the machinery bedplate to chock to foundation plate and the

<sup>1</sup> This practice is under the jurisdiction of ASTM Committee F25 on Ships and Marine Technology and is the direct responsibility of Subcommittee F25.03 on Outfitting.

Current edition approved April 10, 1998. Published November 1998. Originally published as F 1309 - 90. Last previous edition F 1309 - 90.

<sup>2</sup> *Annual Book of ASTM Standards*, Vol 01.03.

<sup>3</sup> *Annual Book of ASTM Standards*, Vol 08.01.

<sup>4</sup> Available from the American Bureau of Shipping, 45 Eisenhower Dr., PO Box 910, Paramus, NJ 07653.

<sup>5</sup> Available from the American Welding Society, 2501 NW 7th St., Miami, FL 33125.

mating areas of the fitted portion of the bolt/stud shank and to the hole wall shall be a minimum of 85 % uniformly distributed around the mating area. A light coat of Prussian blue shall be used to check the contact areas.

4.1.2.3 Machinery shall be aligned using a sufficient number of jackscrews, shims, and wedges to accommodate adequate up-down, port-starboard, and fore-aft movement without distorting the machinery bedplate or foundation plate and, once aligned, be able to hold that alignment firmly during the final chock installation and bolt-fitting phase.

4.1.2.4 A sufficient number of fitted bolts and chocks shall be installed to maintain the alignment and prevent any relative movement between the machinery and the foundation as a result of vibration and sea state inputs. Number and position of fitted bolts shall comply with the engine manufacturer's requirements, if any.

4.1.2.5 Bolts shall be installed from the bottom up unless surrounding interferences dictate otherwise.

4.1.2.6 The length of the fitted portion of the bolt/stud shank shall be 95 % of the combined thickness between spotfaces of the machinery bedplate, chock, and foundation plate.

4.1.2.7 Final reaming of the fitted bolt holes or machining of the bolt shank shall occur after final alignment.

4.1.2.8 Final torquing of each bolt/nut/stub assembly shall be of sufficient torque to preload the nonfitted portions of the bolt/nut/stub enough to prevent loosening as a result of vibrations, operations, hull, and sea state inputs.

4.1.2.9 Welding shall be performed in accordance with American Bureau of Shipping or the American Welding Society, Structural Code AWS D1.1.

#### 4.1.3 *Testing (If Specified):*

4.1.3.1 Steel tension tests shall be made in accordance with Test Methods and Definitions A 370.

4.1.3.2 Compression yield and modulus of elasticity tests shall be made in accordance with Test Method D 695.

4.1.3.3 The tensile ultimate test shall be made in accordance with Test Method D 638.

4.1.3.4 The shear ultimate test, the heat distorting temperature test, and the shock resistance test shall be made in accordance with Test Method D 648.

4.2 *Type A*—Epoxy-based resins are pourable compounds that are poured into properly contained and vented volumes and cure at normal ambient temperatures without shrinkage to form a durable solid.

4.2.1 *Provision for Future Machinery Removal*—To prevent adhesion of chocks to adjoining surfaces and facilitate future removal of machinery, spray an aerosol release agent on all contact surfaces. This precaution allows these chocks to be removed in a similar manner to steel chocks.

#### 4.2.2 *Applicable Techniques:*

4.2.2.1 Position dams to retain the compound during pouring and curing without distortion. Damming materials may be expanded plastic, foam rubber stripping and sheet metal, or light gage flat bar. (See Fig. 1.)

4.2.2.2 Follow resin manufacturer's instructions including the relative design parameters on loading, temperature, allowable thickness, additional design, installation, bolt tension, and inspection.

4.2.3 *Foundation Bolts*—Install hold-down bolts before pouring of resin. Tension (torque) bolts only after resin manufacturer's recommended cure time.

4.3 *Type B, Two-Piece Wedge Chock*—The two-piece wedges are drop-forged, medium steel or machined from steel plate of equal strength or of other materials as specified.

4.3.1 *Applicable Techniques*—Fig. 2 indicates the configuration of Type C chocks to the machinery bedplate and the foundation plate.

4.3.1.1 The taper on the sloped faces of each half of the chock must not exceed a rise of one over a run of four.

4.3.1.2 Align machinery in place as described in 4.1 and install the lower half of the tapered chock in place with the thicker end in first from the place installation. Ensure it does not move by tack welding. Do not allow distortions or separations.

4.3.1.3 Spotface the upper surface of the machinery bedplate where the finish has not been indicated.

4.3.2 *Fitting of Chocks and Bolts*—Fig. 3 indicates the fitting of Type B chocks in way of the bedplates and foundation pieces.

4.3.3 *Bearing Area*—To obtain the 85 % bearing area, either measure the spacing between the machine bedplate and the foundation plate at the four corners in way of the proposed chock location and machine the chocks as a unit to fit or, if the lower half of the taper chock is in place, take the same measurement between it and the machinery bedplate in way of the lower half. Machine the upper half to fit and verify the adequacy of the contact area.

4.3.4 Drill holes in the bottom chock piece and foundation plate, either with machinery unit in place or by the marking of holes and lifting the unit clear. Spotface the bottom side of the foundation plate in way of bolt heads.

4.3.5 *Fitted Bolts*—Fit the bolts/studs to the holes by measuring diameters at 90° to each other in approximately four planes equally spaced through the hole and machine the bolt/stud shank to fit or ream the hole to fit the bolt. Torque the nuts to the proscribed torque.

4.3.6 *Excess Length of Chock*—Determine the length (with an extra allowance for fitting), and the thickness of the topmost piece of the permanent chock assembly (wedge) at installation. Drill the wedge only after it has been finally fitted in place. Face off the excess length flush with plate edges, and preserve the relative positions of chock parts by tackwelding. For the restrictions and size of the taper see Fig. 3.

4.4 *Type C, Solid, One-Piece Fitted Chocks*—The chocks are medium steel machined from plate steel consistent with the machinery bedplate and foundation plate and the loads imposed or of other materials as specified.

4.4.1 *Applicable Techniques*—Fig. 2 indicates the configuration of Type C chocks to the machinery bedplate and the foundation plate.

4.4.2 Align machinery in place as described in 4.1. Do not allow distortions or separations.

4.4.3 *Bearing Area*—To obtain the 85 % bearing area, measure the spacing between the machinery bedplate and the foundation plate, measure the gap at the four corners in way of the proposed chock location as indicated in Fig. 2, machine the

**ASTM F 1309 – 98**

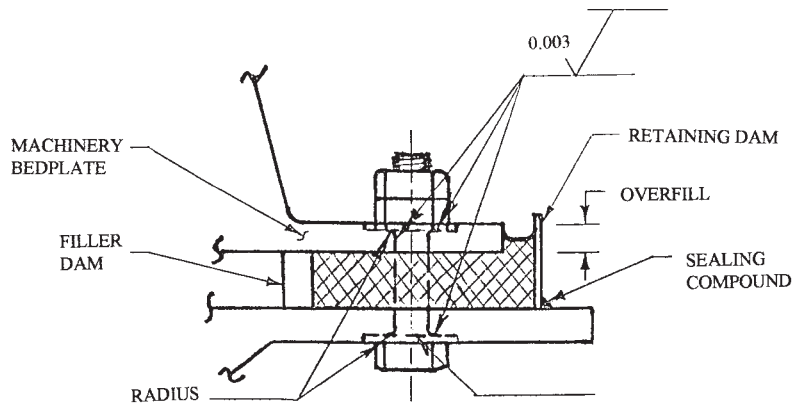

**SECTION A-A**

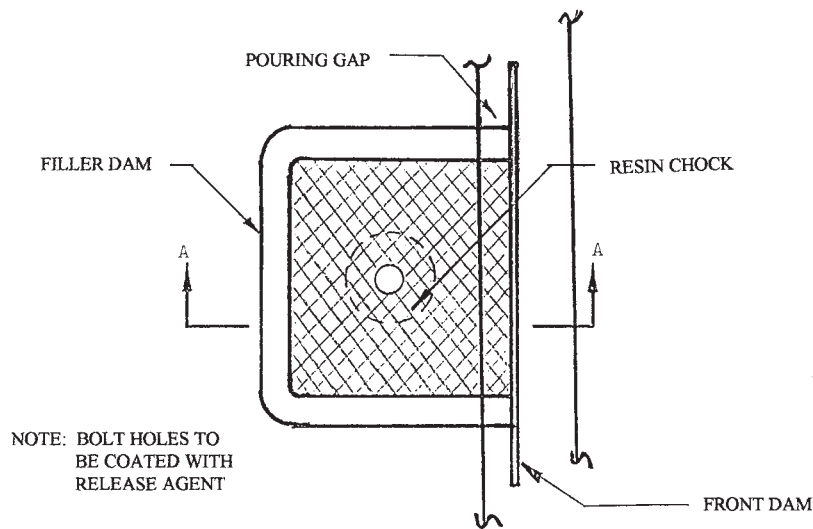

**PLAN VIEW**

**FIG. 1 Type A Epoxy-Based Resin Chock**

chock to fit, and verify the adequacy of the bearing area.

4.4.4 *Fitted Bolts*—Fit the bolts/studs to the holes by measuring diameters at 90° to each other in approximately four planes equally spaced through the hole and machine the bolt/stub shank to fit or ream the hole to fit the bolt/stud.

Torque the nuts to the proscribed torque.

**5. Keywords**

5.1 chocks; fitting chocks; foundations; installation; machinery foundations, marine; procedures; ship

**ASTM F 1309 – 98**

NOTE: A, B, C & D DIMENSIONS ARE TO BE MACHINED ONTO THE RELATIVE POSITIONS OF THE CHOCK TO OBTAIN PROPER FIT.

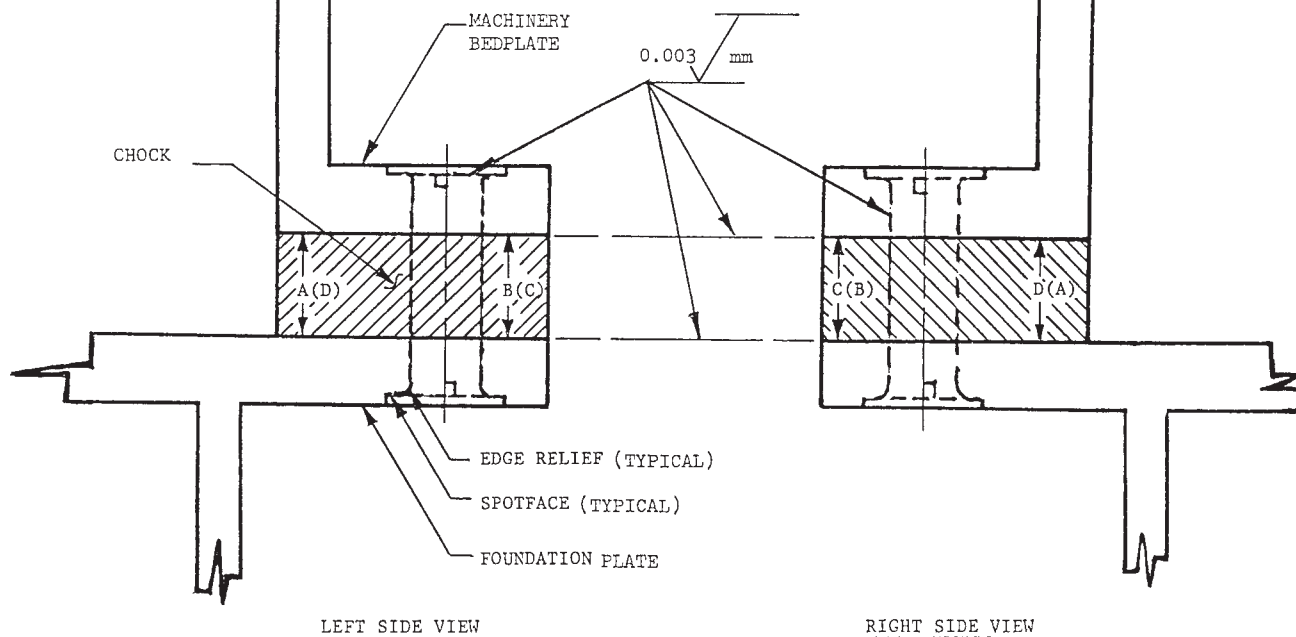

**FIG. 2 Type C Chock Solid (One Piece)**

**SUPPLEMENTARY REQUIREMENTS**

**S1. Scope**

S1.1 Supplementary requirements only apply if specified in the contract or purchase order.

**S2. Reference Documents**

S2.1 *Military Document:*  
MIL-S-901 Shock Tests, H.I. (High Impact); Shipboard,

Machinery, Equipment and Systems, Requirements for<sup>6</sup>

**Supplementary Test Requirements**

S3.1 If specified, shock in accordance with MIL-S-901.

<sup>6</sup> Available from Naval Publications and Forms Center, 5801 Tabor Ave., Philadelphia, PA 19120-5099, Attn: NPODS.

**ASTM F 1309 - 98**

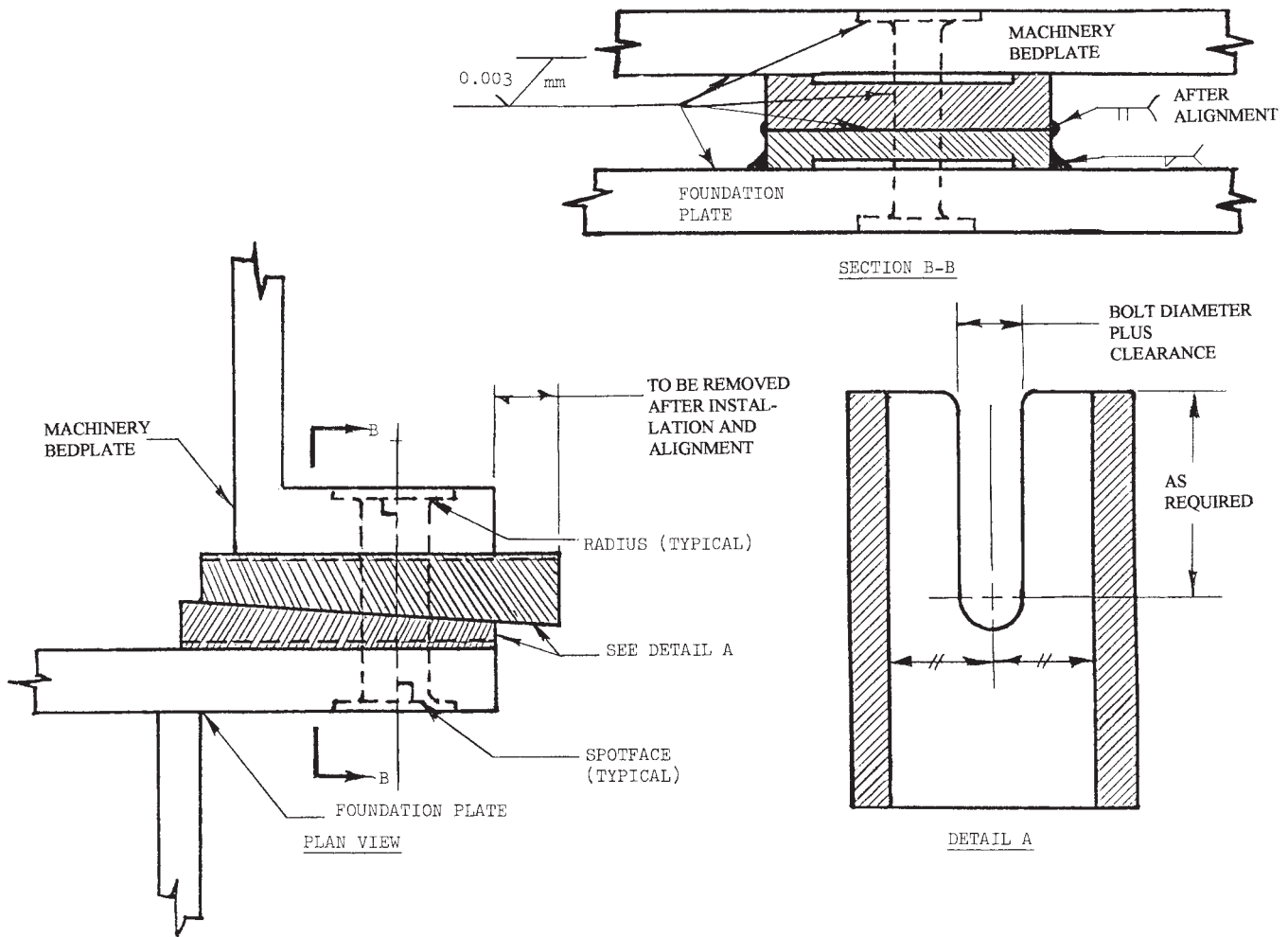

NOTE 1—1 in. = 25.4 mm

**FIG. 3 Type B, Wedge Chocks (Two Piece)**

ASTM International takes no position respecting the validity of any patent rights asserted in connection with any item mentioned in this standard. Users of this standard are expressly advised that determination of the validity of any such patent rights, and the risk of infringement of such rights, are entirely their own responsibility.

This standard is subject to revision at any time by the responsible technical committee and must be reviewed every five years and if not revised, either reapproved or withdrawn. Your comments are invited either for revision of this standard or for additional standards and should be addressed to ASTM International Headquarters. Your comments will receive careful consideration at a meeting of the responsible technical committee, which you may attend. If you feel that your comments have not received a fair hearing you should make your views known to the ASTM Committee on Standards, at the address shown below.

This standard is copyrighted by ASTM International, 100 Barr Harbor Drive, PO Box C700, West Conshohocken, PA 19428-2959, United States. Individual reprints (single or multiple copies) of this standard may be obtained by contacting ASTM at the above address or at 610-832-9585 (phone), 610-832-9555 (fax), or service@astm.org (e-mail); or through the ASTM website (www.astm.org).