



Standard Specification for Pressure-Reducing Manifolds for Air or Nitrogen Systems¹

This standard is issued under the fixed designation F 1685; the number immediately following the designation indicates the year of original adoption or, in the case of revision, the year of last revision. A number in parentheses indicates the year of last approval. A superscript epsilon (ϵ) indicates an editorial change since the last revision or reapproval.

1. Scope

1.1 This specification covers the design, construction, testing and operating requirements for pressure-reducing manifolds for air or nitrogen systems, referred to herein also as manifolds. The term manifold constitutes the combination of all components and piping between, and including, the inlet and outlet ports (see Fig. 1 and Fig. 2).

1.2 The values stated in inch-pound units are to be regarded as the standard. The values given in parentheses (metric SI units) are for information only.

2. Referenced Documents

2.1 ASTM Standards:

F 992 Specification for Valve Label Plates²

F 1508 Specification for Angle Style, Pressure Relief Valves for Steam, Gas, and Liquid Services²

F 1795 Specification for Pressure-Reducing Valves for Air or Nitrogen Systems²

2.2 American Society of Mechanical Engineers (ASME):

B1.1 Unified Screw Threads³

2.3 Military Standards and Specifications:

MIL-STD-167-1 Mechanical Vibrations of Shipboard Equipment (Type I—Environmental and Type II—Internally Excited)⁴

MIL-STD-740 Airborne and Structureborne Noise Measurements and Acceptance Criteria of Shipboard Equipment⁴

MS 16142 Boss, Gasket Seal Straight Thread Tube Fitting, Standard Dimensions for⁴

MIL-S-901 Shock Tests, H.I. (High-Impact); Shipboard Machinery, Equipment and Systems, Requirements for⁴

MIL-F-1183 Fittings, Pipe, Cast Bronze, Silver-Brazing, General Specification for⁴

2.4 Government Drawings:

Naval Sea Systems Command (NAVSEA):

NAVSEA 803-1385884 Unions, Fittings and Adapters Butt and Socket Welding 6000 PSI, WOG and OXY (IPS)⁴

NAVSEA 803-1385943 Unions, Silver Brazing 3000 PSI, WOG, IPS, for UT Inspection⁴

NAVSEA 803-1385946 Unions, Bronze, Silver Brazing, WOG for UT Inspection, 1500 PSI, WOG⁴

3. Terminology

3.1 Definitions:

3.1.1 *accuracy of regulation*—the amount by which the downstream pressure may vary when the manifold is set at any pressure within the required set pressure range and is subjected to any combination of inlet pressure, flow demand, and ambient temperature variations within the specified limits.

3.1.2 *bubble-tight*—No visible leakage over a 5-min period using either water submersion or the application of bubble fluid for detection.

3.1.3 *external leakage*—Leakage from the manifold which escapes to atmosphere.

3.1.4 *flow rate demand*—the amount of flow demanded at any given time by the system downstream of the manifold.

3.1.5 *flow rate demand range*—the range over which the flow demand can vary.

3.1.6 *hydrostatic shell test pressures*—the hydrostatic test pressures that the inlet and outlet sections of the manifold are required to withstand without damage. Manifold operation is not required during application of shell test pressure, but the manifold must meet all performance requirements after the shell test pressure has been removed.

3.1.7 *inlet operating pressure range*—the range over which the inlet pressure supplied to the manifold can vary under any operational conditions which the manifold can be subjected to in service.

3.1.8 *internal leakage*—leakage from higher pressure to lower pressure portions of the manifold and which does not escape to atmosphere.

3.1.9 *manifold rated pressures*—the inlet and outlet pressure ratings of the manifold. These rated pressures are selected from the applicable pressure ratings (see 4.2) and specified in the ordering information (see Section 5). The inlet pressure rating is applicable from the manifold inlet up to and including the seats of the outlet stop valve and bypass throttle valve. The

¹ This specification is under the jurisdiction of ASTM Committee F25 on Ships and Marine Technology and is under the direct responsibility of Subcommittee F25.11 on Machinery and Piping Systems.

Current edition approved May 10, 2000. Published August 2000. Originally published as F 1685 - 96. Last previous edition F 1685 - 96.

² *Annual Book of ASTM Standards*, Vol 01.07.

³ Available from American Society of Mechanical Engineers, Headquarters, Three Park Ave., New York, NY 10016-5990. Telephone: 212-591-7722, Fax: 212-591-7674, Telex: 710-591-5267.

⁴ Available from Standardization Documents Order Desk, Bldg. 4 Section D, 700 Robbins Ave., Philadelphia, PA 19111-5094, Attn: NPODS.

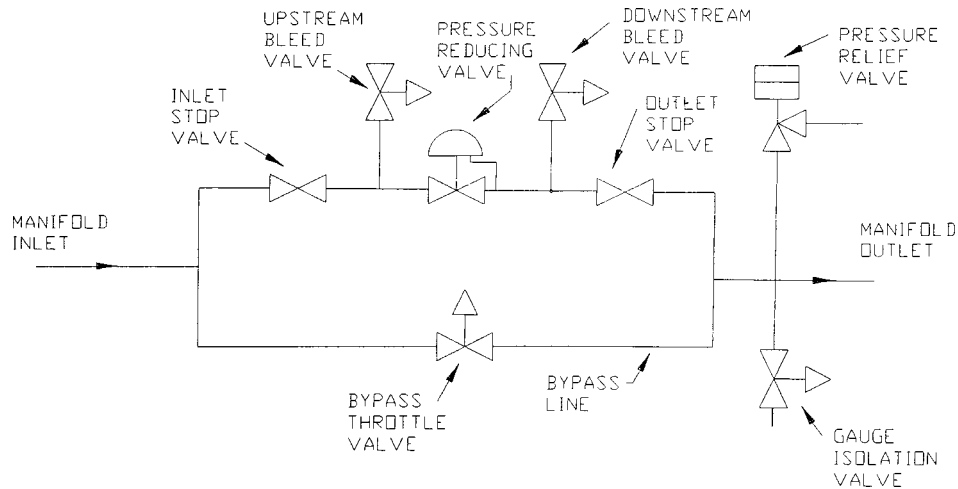

FIG. 1 Manifold Configuration

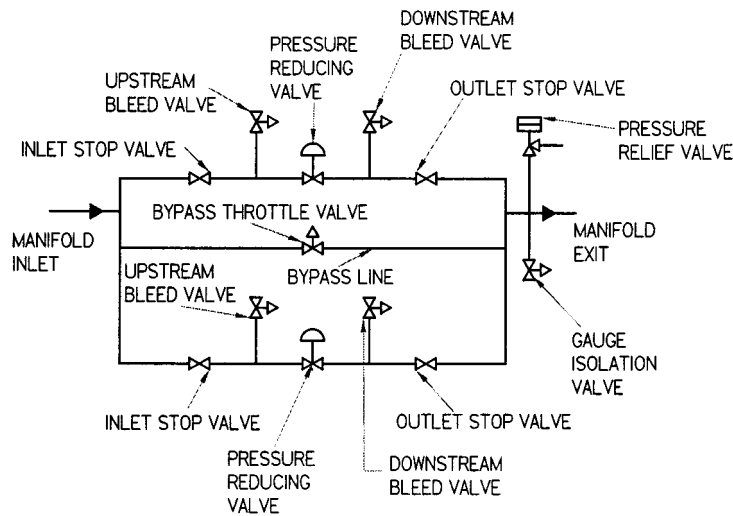

FIG. 2 Manifold Configuration

outlet pressure rating is applicable from the outlet side of the seats of the outlet stop valve to the manifold outlet and the bypass throttle valve to the manifold outlet.

3.1.10 *manual valves*—these are all the manually operated valves in the manifold which include handwheel-operated valves and wrench-operated valves. The handwheel-operated valves are the inlet and outlet stop valves, and the bypass throttle valve. The wrench-operated valves are the upstream and downstream bleed valves and the gage isolation valve. The requirements for any manually operated valves installed in the pressure-reducing valve are covered under 6.5.1.

3.1.11 *maximum flow rate demand*—the maximum amount of flow demanded of the manifold by the downstream system.

3.1.12 *maximum inlet operating pressure*—the highest pressure supplied to the inlet of the manifold in service.

3.1.13 *maximum outlet operating pressure*—the highest pressure at the manifold outlet in service. This is established by the accumulation pressure of the pressure-relief valve.

3.1.14 *maximum set pressure*—the highest set pressure at which the manifold can meet the performance requirements specified.

3.1.15 *minimum flow rate demand*—the minimum flow rate demanded of the manifold by the downstream system.

3.1.16 *minimum inlet operating pressure*—the lowest pressure supplied to the inlet of the manifold in service.

3.1.17 *minimum outlet operating pressure*—the lowest pressure at the manifold outlet in service. This is established by the accuracy of regulation of the pressure-reducing valve.

3.1.18 *minimum set pressure*—the lowest set pressure at which the manifold can meet the performance requirements specified.

3.1.19 *operating pressures*—the pressures within the manifold during service.

3.1.20 *pressure-reducing valve*—the component of the manifold which accomplishes automatic regulation of the downstream pressure. In this component, the upstream pressure is reduced to the desired downstream pressure.

3.1.21 *pressure-relief valve*—the component of the manifold which protects the manifold and downstream systems against downstream over pressurization.

3.1.22 *set pressure*—the outlet pressure delivered by the manifold at the time the pressure setting is made. For the

purposes of this specification, it will be assumed that the setting is made when there is no flow demand on the manifold ("lock-up" condition), and the manifold is at surrounding ambient temperature.

3.1.23 *set pressure range*—the range of set pressures over which the manifold can be adjusted while meeting the performance requirements specified.

3.1.24 *wide open capacity*—the flow rate when a valve is in a position which presents the least resistance to flow.

4. Classification

4.1 *Configuration*—Manifolds shall be of the following configurations and specified in the ordering information (see 5.1).

Configuration 1-1 One reducer, one relief (see Fig. 1).

Configuration 2-1 Two reducers, one relief (see Fig. 2).

4.2 *Pressure Ratings*—Manifolds shall have inlet-rated pressures and outlet-rated pressures selected from the following categories: 400-, 1500-, 3000-, and 6000-psig (2.8-, 10.3-, 20.7-, and 41.4-MPa gage pressure). The inlet and outlet pressure ratings selected shall be specified in Section 5.

4.3 *End Connections*—Manifolds shall have inlet and outlet end connections selected from those listed in Table 1 and specified in Section 5.

5. Ordering Information

5.1 Ordering documentation for manifolds under this specification shall include the following information, as required, to describe the equipment adequately:

5.1.1 ASTM designation and year of issue,

5.1.2 Size and type of inlet end connection (see 4.3 and 6.4.2),

5.1.3 Size and type of outlet end connection (see 4.3 and 6.4.2),

5.1.4 Size and type of end connections for pressure-reducing valve and pressure-relief valve,

5.1.5 If tail pieces and union nuts are required (when required, their material of construction shall be per Table 1),

5.1.6 Manifold configuration, inlet and outlet pressure ratings (see 4.1 and 4.2),

5.1.7 Manifold inlet operating pressure range,

5.1.8 Type of mounting required: bottom or back mounting (see 6.4.3),

5.1.9 Set pressure and set pressure range, if other than specified (see 7.3),

5.1.10 Flow rate demand range (see 7.1, S1.1.6),

5.1.11 Accuracy of regulation required, if other than specified, or if set pressure is below 10 psig (see 7.2),

5.1.12 Relief valve set pressure and accumulation pressure (if different from Specification F 1508),

5.1.13 Ambient atmospheric conditions: temperature range, chemical contaminants, if any,

5.1.14 Quality of inlet air/nitrogen gas: temperature range, moisture content, oil/lubricant contaminants, if any,

5.1.15 Special tools required (see 6.7),

5.1.16 Tamper-proof lead seal if required (see Specification F 1795, Section 5),

5.1.17 Supplementary requirements, if any (S1 through S4), and

5.1.18 Maximum vibration frequency, if other than specified (see S1.1.9).

6. Manifold Construction

6.1 Manifolds shall incorporate the design features specified in 6.2-6.11.

6.2 *Materials of Construction*—Material requirements for the assemblies in the manifold shall be as specified in the applicable component specifications referenced herein. Materials for all other parts, including the inlet and outlet manifold blocks, shall be 300 series corrosion-resistant steel (SS304, 304L, 316, or 316L) or other materials selected to provide weldability and corrosion resistance without requiring painting, coating, or plating. The inlet and outlet manifold blocks shall be weld repairable. Materials for contacting parts shall be selected to minimize electrolytic corrosion and galling. Metallic materials shall conform to applicable ASTM specifications. Nonmetallic materials shall be compatible with the line medium.

6.3 *General Requirements*—Manifolds shall incorporate the functional elements shown schematically in Fig. 1 or Fig. 2, as applicable, and delineated below:

(a) Inlet and outlet stop valves,

(b) Upstream and downstream bleed valves (for depressurization of all components and fluid cavities.),

(c) Pressure-reducing valve(s),

(d) Pressure-relief valve,

(e) Gauge isolation valve, and

(f) Bypass throttle valve.

All components shall be part of a manifold assembly, as shown in Fig. 3 or Fig. 4, as applicable, which requires only one inlet and one outlet connection to the main flow path of the piping system in which it is installed. The inlet and outlet connections shall be in-line. The manifold shall be fabricated from inlet and outlet blocks, with interconnecting piping for the pressure-reducing valve(s) and bypass throttle valve flow paths. The manual valves shall be cartridge mounted into the inlet and outlet manifold blocks as shown in Fig. 3 or Fig. 4, as applicable. The pressure-reducing valve and the pressure-relief valve shall be mounted by way of takedown connections in accordance with Table 1. The manifold shall be capable of meeting all requirements of this specification and provide extended reliable operation when protected by a 5- μ m nominal/

TABLE 1 Manifold Inlet and Outlet End Connections

Type of End Connection	Pressure Rating, lb/in ² (MPa)	Applicable Documents
Union ^A , silver-brazed	400 (2.8)	MIL-F-1183 (O-ring type)
Union ^A , silver-brazed	1500 (10.3)	803-1385946
Union ^A , silver-brazed	3000 (20.5)	803-1385943
Union ^A , butt/socket weld	6000 (41.4)	803-1385884
As specified	As specified	As specified

^AOnly the pertinent dimensions listed in the applicable documents applicable to the straight thread portion of the thread piece shall apply. Thread pieces shall be secured to the manifold inlet and outlet blocks using straight threads and a O-ring seal design. For the manifold inlet and outlet connections, unless otherwise specified in Section 5 the tail pieces and the union nuts shall not be furnished—only the thread pieces shall be furnished. If tail pieces and union nuts are required, their materials of construction shall be in accordance with the applicable documents listed above and shall be specified in Section 5.

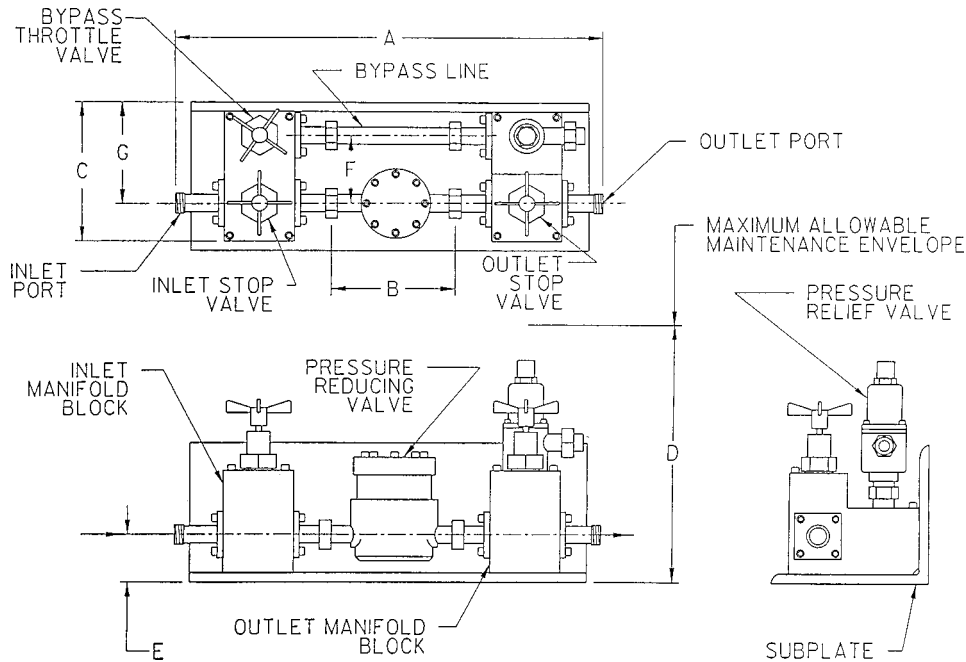

NOTE 1—Pictorial representations are for illustrative purposes only and do not imply design.

FIG. 3 Components of a Manifold Assembly

18- μ m absolute filter installed upstream of the manifold inlet and when subjected to conditions specified in Section 5.

6.4 Design Construction Requirements

6.4.1 *Pressure Envelope*—The hydrostatic shell test pressures shall be 1.5 times the manifold rated inlet and outlet pressures.

6.4.2 *Connections*—The main-line inlet and outlet connections of the manifold, the inlet and outlet connections of the pressure-reducing valve(s), the connections for the bypass line, and the inlet and outlet connection to the pressure-relief valve shall be takedown joints (unions or other as specified) as specified in Table 1 based on rated pressures specified. Any exposed threads shall be protected by plastic caps for shipping. The main-line inlet and outlet connection of the manifold and the inlet and outlet connection for the pressure-reducing valve(s) shall permit axial adjustment to expedite proper installation of the manifold into the piping system and to facilitate replacement of the pressure-reducing valve(s) with one of another make or model or which is for some other reason not dimensionally identical to the originally installed pressure-reducing valve(s). The axial adjustment feature for the pressure-reducing valve(s) shall be included in that portion of the takedown joints that are connected to the inlet and outlet manifold blocks. If unions per Table 1 are specified for the pressure-reducing valve(s) inlet and outlet connections, the thread pieces shall be the portions of the unions that are attached to the pressure-reducing valve(s). The range over which each of the four adjustable connections noted above can be adjusted shall be as specified in Table 2. A positive and permanent means shall be incorporated to ensure that none of the four adjustable connections can be backed out beyond their minimum engagement position. The size of the main-line inlet and outlet connections of the manifold shall be as specified (see Section 5).

6.4.3 *Manifold Mounting*—The manifold shall be given structural integrity by means of a subplate provided as part of the manifold. The subplate shall be an angle form to provide an accurate mounting surface for both back and bottom mounting and shall be bolted to the inlet and outlet manifold blocks in such a way as to not interfere with mounting the manifold to a foundation plate. The manifold shall be drilled and tapped or through-drilled to allow either bottom mounting or back mounting as specified (see Section 5). All components shall be fully and easily accessible for operation, service, or removal from the manifold.

6.4.4 *Threads*—Threads shall be as specified in ASME B1.1. Where necessary, provisions shall be incorporated to prevent the accidental loosening of threaded parts. The design shall be such that standard wrenches can be used on all external bolting. Lock wire shall not be used.

6.4.5 *Interchangeability*—The entire manifold, including components and all associated piece parts, shall have part number identity and shall be replaceable from stock or the manufacturer on a nonselective and random basis. Parts having the same manufacturer's part number shall be directly interchangeable with each other with respect to installation (physical) and performance (function). Physically interchangeable assemblies, components, and parts are those that are capable of being readily installed, removed, or replaced without alteration, misalignment, or damage to parts being installed or to adjoining parts. Fabrication operations such as cutting, filing, drilling, reaming, hammering, bending, prying, or forcing shall not be required.

6.4.6 *Nonmetallic Element Interchangeability*—Nonmetallic elements, including but not limited to, seat rings, poppet seat inserts, cushions, and O-rings, shall be treated as separately identified and readily replaceable parts.

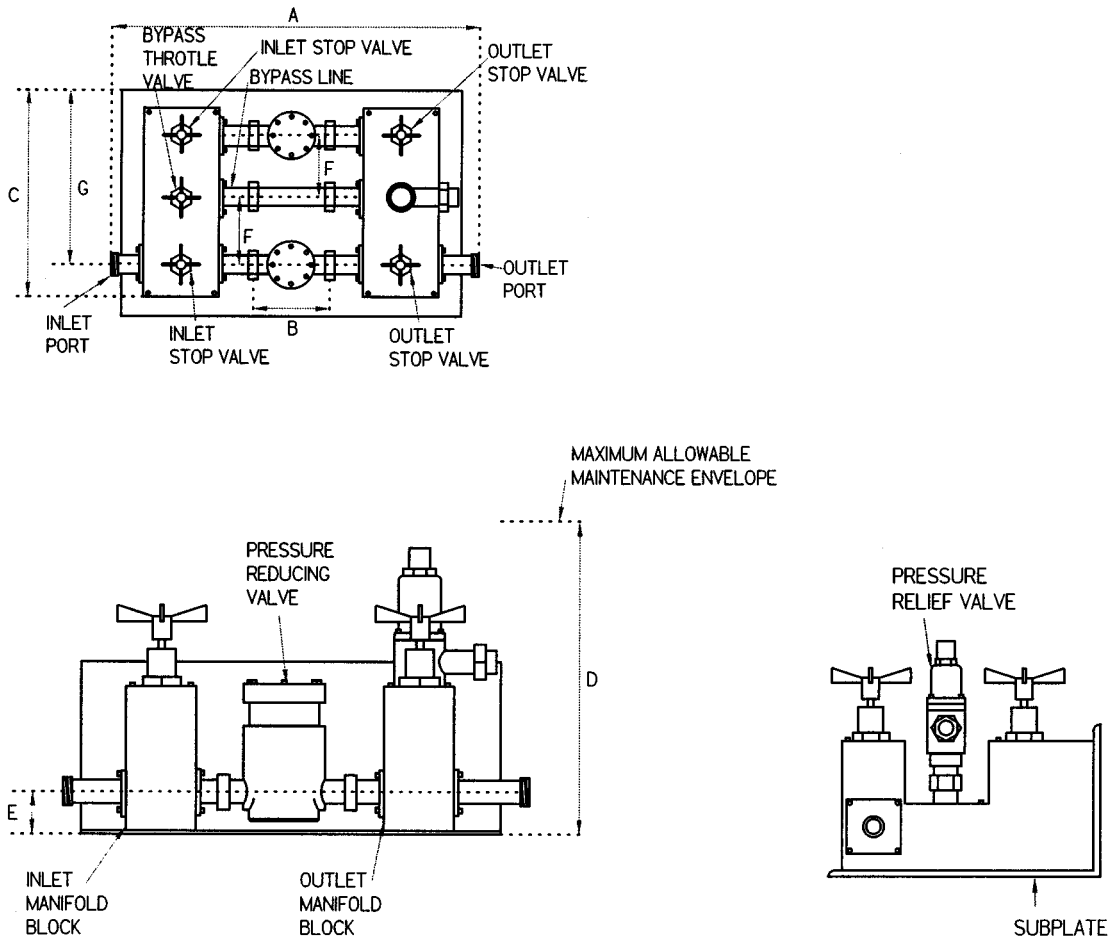

FIG. 4 Components of Manifold Assembly

TABLE 2 Adjustable Range of End Connections

Connection Size Nominal Pipe Size NPS (Dimension Nominal DN)	Minimum Adjustment Range of Each Connection, in. (mm)
1/4 and 3/8 (8 and 10)	3/8 (10)
1/2, 3/4, 1, and 1 1/4 (15, 20, 25, and 32)	1/2 (13)
1 1/2 and 2 (40 and 50)	3/4 (19)

6.4.7 *Pressure Gage*—The manifold shall be provided with a 1/4-in. (DN 8) threaded gage connection port to permit attachment of a pressure gage for sensing the outlet pressure. The gage connection under all operating conditions shall be located to measure accurately pressure at the manifold outlet connection when using either the pressure-reducing valve or the bypass throttle valve to control flow. A gage isolation valve shall be provided in the manifold.

6.4.8 *Bleed Valves*—Bleed valves as shown in Fig. 1 and Fig. 2 shall be provided to allow depressurization of piping and components.

6.5 *Component Requirements:*

6.5.1 *Pressure-Reducing Valve*—Pressure-reducing valve(s) incorporated in the manifold shall be in accordance with Specification F 1795, Type I construction. The pressure rating shall be in accordance with 4.2 and shall equal the manifold inlet pressure rating.

6.5.1.1 *Pressure reversal*—The manifold shall withstand, without damage, a condition in which the pressure-reducing valve is subjected to a maximum reverse pressure differential. This can occur where the maximum set pressure exists at the pressure-reducing valve outlet, the pressure-reducing valve loading element is deactivated (that is, if it is a spring-loaded, pressure-reducing valve, the set spring adjustment is backed off fully; and if a gas-dome loaded pressure-reducing valve, the dome charge is vented off completely), and inlet pressure is vented off.

6.5.2 *Pressure-Relief Valve*—The requirements and definitions for the pressure-relief valve incorporated in the manifold shall be as specified in Specification F 1508.

6.5.3 *Manual Valves*—The requirements for the manual valves incorporated in the manifold shall be as specified in 6.5.3.1-6.5.3.6.

6.5.3.1 *Mounting*—All manual valves shall be cartridge mounted into the manifold blocks.

6.5.3.2 *Seats*—Each manual valve shall incorporate a non-metallic seating feature for tight shutoff.

6.5.3.3 *Handwheel operating force*—For hand-operated valves, the maximum permissible total tangential force required on the rim of the handwheel for operating, or seating/unseating the valves shall not exceed 50 lbs (220 N) when the valve is subjected to the maximum operating pressure.

6.5.3.4 *Bidirectional shutoff*—All manual valves shall be capable of operation and tight shutoff when pressure is applied in either direction.

6.5.3.5 *Pressurization rate*—All manual valves shall be capable of being operated to limit the rate of downstream pressure buildup in a depressurized volume (with maximum pressure upstream) to 200-psig (1379-KPa gage pressure) per second. Downstream volumes for this pressurization rate requirement shall be taken as the applicable manifold volumes. For design and test purposes, a stop valve not more than ten diameters downstream of the manifold outlet connection shall be assumed.

6.5.3.6 *Bypass throttle valve*—The bypass throttle valve shall be sized to pass full-rated flow of the manifold and control the outlet pressure at all flow demands and inlet pressures within the range of the manifold.

6.6 *Manifold Envelope Dimensions*—Manifold envelope dimensions shall be as specified in Fig. 3 or Fig. 4 and Table 3, as applicable.

6.7 *Maintainability*—The manifold shall permit direct access for disassembly, repair, and reassembly of all internal working parts and subassemblies when mounted for operation on its subplate and installed into the system. Maintenance shall require standard tools to the maximum extent possible. Any special tools required for maintenance shall be identified and shall be supplied when ordered (see Section 5).

6.8 *Reversibility*—Seating inserts shall not be physically reversible unless they are also functionally reversible to preclude incorrect assembly.

6.9 *Adjustments*—There shall be no adjustments required in the manifold during or after assembly other than the axial positioning of the takedown connections for installation of the pressure-reducing valve into the manifold or installation of the manifold into the system and the set points of the pressure-reducing valve and the pressure-relief valve.

6.10 *Reliability*—Periodic maintenance of the manifold or any of its components shall not be required. There shall be no postassembly lubrication required.

6.11 *Ruggedness*—To the maximum extent practical, the manifold and its components shall be designed to prevent damage, malfunction, or leakage as a result of foreign particle or other line media contamination or from mishandling.

7. Performance

7.1 Manifolds shall meet the performance requirements of 7.2-7.7.

7.2 *Flow Capacity*—The maximum and minimum flow rate demand required shall be specified (see Section 5) in standard cubic feet per minute at 60°F (15.6°C) and 14.7 psia (101 kPa absolute). The manifold shall meet the specified maximum and minimum flow rate demand requirements, or any intermediate flow rate demand requirement, and shall operate without hunting or chattering under all specified conditions.

7.3 *Accuracy of Regulation*—Manifold regulated pressure shall be maintained within the accuracy of regulation limits specified in Table 4 (unless different limits are specified in Section 5) under all flow rate demand and inlet pressure conditions specified.

7.4 *Range of Set Pressure Adjustment (Set Pressure Limits)*—Unless otherwise specified in Section 5, the set pressure range shall be as follows: Where the manifold uses a mechanical spring, the set pressure shall be adjustable through a range of at least 5 % or 2 psi (14 kPa), whichever is greater, on either side of the specified set pressure. Where the manifold uses a gas spring (dome loading), the set point shall be adjustable through a range of at least 25 % or 10 psi (69 kPa), whichever is greater, on either side of the specified set pressure.

7.5 *Accumulation*—The pressure-relief valve shall be sized to pass at the maximum inlet pressure the wide open capacity of the pressure-reducing valve, or the wide open capacity of the by-pass throttle valve, whichever is greater, and limit the downstream pressure to the accumulation pressure. The accumulation (overpressure) limits shall be per Specification F 1508.

TABLE 3 Envelope Dimensions of Manifolds

Manifold Size (Inlet × Outlet), in. (DN Metric)	Distance Between Takedown Joints (At Adj Mid-Pt)		C ±0.12 in. Configuration 1-1 (±3 mm)	C ±0.12 Configuration 2-1 (± 3 mm)	D (Max) in. (mm)	E ±0.06 in. (±2 mm)	F Min (mm)	G ±0.06 (±2 mm)
	A ±0.12 in. (±3 mm)	B ±0.12 in. (±3 mm)						
¼ × ¼ (DN 8 × 8)	19 (483)	6¼ (159)	6½ (165)	9½ (241)	12 (305)	4 (102)	3½ (89)	5 (127)
¼ × ½ (DN 8 × 15)	19½ (495)	6½ (165)	7 (178)	10¼ (260)	12¼ (311)	4¼ (108)	3¾ (95)	5¾ (137)
¼ × ¾ (DN 8 × 20)	20 (508)	6¾ (171)	7½ (191)	10¼ (260)	12½ (318)	4½ (114)	4 (102)	6½ (156)
⅜ × ⅜ (DN 10 × 10)	21 (533)	7 (178)	8 (203)	11½ (292)	13 (330)	4¾ (121)	4½ (114)	6¼ (159)
⅜ × ½ (DN 10 × 15)	21½ (546)	7¼ (184)	8½ (216)	12¼ (311)	13¼ (337)	5 (127)	4¾ (121)	6½ (169)
⅜ × ¾ (DN 10 × 20)	22 (559)	7½ (191)	9 (229)	13 (330)	13½ (343)	5¼ (133)	5 (127)	7 (178)
½ × ½ (DN 15 × 15)	23 (584)	8 (203)	9½ (241)	14 (356)	14 (356)	5½ (140)	5 (127)	7¼ (184)
½ × ¾ (DN 15 × 20)	23½ (597)	8¼ (210)	10 (254)	14¾ (375)	14¼ (362)	5¾ (146)	5¼ (133)	7½ (194)
½ × 1 (DN 15 × 25)	24 (610)	9½ (241)	10½ (267)	15½ (394)	14½ (368)	6 (152)	5½ (140)	8 (203)
¾ × ¾ (DN 20 × 20)	25 (635)	9 (229)	11 (279)	16½ (419)	15 (381)	6¼ (159)	5 (146)	8¼ (210)
¾ × 1 (DN 20 × 25)	25½ (648)	9¼ (235)	11½ (292)	17¼ (438)	15¼ (387)	6½ (165)	6 (152)	8½ (219)
¾ × 1¼ (DN 20 × 32)	26 (660)	9½ (241)	12 (305)	18 (457)	15½ (394)	6¾ (171)	6¼ (159)	9 (229)
¾ × 1½ (DN 20 × 40)	26 (660)	9½ (241)	12 (305)	18 (457)	15½ (394)	6¾ (171)	6¼ (159)	9 (229)
1 × 1 (DN 25 × 25)	27 (686)	10 (254)	12½ (318)	18½ (470)	16 (406)	7 (178)	6½ (165)	9½ (241)
1 × 1¼ (DN 25 × 32)	27½ (699)	10¼ (260)	13 (330)	19¼ (489)	16¼ (413)	7¼ (184)	6 (171)	9½ (251)
1 × 1½ (DN 25 × 40)	27½ (699)	10¼ (260)	13 (330)	19¼ (489)	16¼ (413)	7¼ (184)	6¾ (171)	9½ (251)
1 × 2 (DN 25 × 50)	28 (711)	10½ (267)	13½ (343)	19½ (495)	16½ (419)	7½ (191)	7 (178)	10½ (267)

TABLE 4 Accuracy of Regulation

NOTE 1—For set pressures below 10-psig (69-kPa gage pressure), the required accuracy of regulation shall be as specified in Section 5.

Set Pressure, psig (kPa Gage Pressure)	Accuracy of Regulation (Percent of Set Pressure)
10–25 (69–172)	(–30/+5 %)
26–50 (179–345)	(–20/+5 %)
51–100 (352–689)	(–16/+2 %)
101–250 (696–1724)	(–12/+2 %)
251–750 (1731–5171)	(–10/+2 %)
751–1000 (5178–6895)	(–9/+1 %)
above 1000 (above 6895)	(–7/+1 %)

7.6 *Seat Tightness*—Handwheel-operated valves shall be bubble-tight in both directions when closed with a force not exceeding that specified in 6.5.3.3 (or the manufacturers' recommendations, when less). The pressure-reducing valve shall meet the seat tightness requirements of 8.5. Where necessary, leakage measurement shall start after temperature stabilization.

7.7 *External Leakage*—Manifold external leakage shall be bubble-tight at operating pressure conditions over a 5-min period.

8. Tests Required

8.1 Each manifold shall pass the tests outlined in 8.2-8.6.

8.2 *Visual Examination*—The manifold shall be examined visually to determine conformance with the ordering data, interface dimensions, and workmanship without disassembly.

8.3 *Hydrostatic Shell Test*—The manifold shall be hydrostatically tested by applying pressures equal to 1.5 times the manifold rated inlet and outlet pressures to the inlet and outlet ports, respectively, to check the structural integrity of the manifold. Pressure shall be applied for 5 min. Air or nitrogen may be used in lieu of water providing appropriate safety precautions are taken to minimize the risk associated with the use of a compressible fluid. There shall be no external leakage, permanent distortion, or structural failure.

8.4 *Relief-Valve Lift Test*—Pressure at the pressure-relief valve inlet shall be increased until the pressure-relief valve lifts. Pressure shall then be decreased until the pressure-relief valve reseats. The pressure-relief valve shall lift and reseat within the limits specified in Specification F 1508. There shall be no evidence of operational instability or damage to the pressure-relief valve.

8.5 *Seat Tightness Test*—Handwheel-operated valves shall be seated with a torque not exceeding that specified in 6.5.3.3 (or the manufacturers' recommendations, when less). Air, at the maximum inlet operating pressure each valve is subjected to in service, shall be used for seat leakage tests, using bubble fluid or immersing the outlet, or a line from the outlet, under water. The outlet stop valve shall also be tested in the outlet-to-inlet direction, applying a pressure at the outlet of the valve equal to the maximum outlet-section rating of the manifold. Pressure-reducing valves shall be tested with an inlet pressure equal to the inlet rated pressure of the manifold. Pressure-relief valves shall be tested at the reseat pressure

applicable to their setting in accordance with Specification F 1508. None of the valves shall show visible evidence of leakage over a 5-min period. The following procedure shall be used to check the pressure-reducing valve seat tightness: The valve shall be isolated downstream. The dead-ended volume shall be tight and shall not exceed ten diameters of downstream pipe. It shall be monitored with bubble fluid to assure tightness. With full-rated inlet pressure, there shall be no detectable rise in the outlet pressure over a 15-min period after manifold temperature stabilizes.

8.6 *External Leakage Test*—Air shall be applied at the appropriate rated pressure to each section of the manifold. External leakage shall be checked using bubble fluid or by submerging the manifold in water. There shall be no visible external leakage over a 5-min period.

9. Marking

9.1 *Identification Plate*—An identification plate of corrosion-resistant metal in accordance with Specification F 992; Types I, II, III, or IV shall be permanently attached to the manifold and shall include the following information (some or all information may instead be stamped or etched on the manifold blocks):

9.1.1 Manufacturer's name,

9.1.2 ASTM designation and year of issue

9.1.3 Nominal operating conditions (inlet pressure, set pressure, and flow capacity), and

9.1.4 Manufacturer's model/part number.

9.2 *Component Marking*—The pressure-reducing valve, pressure-relief valve, and each manual valve shall be marked or have an identification plate listing the manufacturer's name and model/part number.

9.3 *Handwheel-Operated Valve Marking*—Each handwheel-operated valve shall be clearly marked to show its function in the manifold (for example, "Inlet Stop Valve," "Outlet Stop Valve," and "Bypass Throttle Valve") and direction of operation of the handwheel movement to open or close the valve.

10. Quality Assurance System

10.1 The manufacturer shall establish and maintain a quality assurance system that will ensure all the requirements of this specification are satisfied. This system shall also ensure that all manifolds will perform in a similar manner to those representative manifolds subjected to original testing for determination of the operating and flow characteristics.

10.2 A written description of the quality assurance system the manufacturer will use shall be available for review and acceptance by the inspection authority.

10.3 The purchaser reserves the right to witness the production tests and inspect the manifolds in the manufacturer's plant to the extent specified on the purchase order.

11. Keywords

11.1 air systems; nitrogen systems; pressure-reducing manifolds

SUPPLEMENTARY REQUIREMENTS

One or more of the following supplementary requirements S1, S2, S3, or S4 shall be applied only when specified by the purchaser in the inquiry, contract, or order. Details of those supplementary requirements shall be agreed upon in writing by the manufacturer and purchaser. Supplementary requirements shall in no way negate any requirement of the specification itself.

S1. Initial Qualification Testing

S1.1 Qualification tests shall be conducted at a facility satisfactory to the customer and shall consist of the examinations and tests selected from those specified in S1.1.1 through S1.1.11 and delineated in the ordering data. The tests may be conducted on representative manifold sizes and pressure classes to qualify all sizes and pressure classes of manifolds, provided the manifolds are of the same type and design. Evidence of prior approval of these tests is acceptable.

S1.1.1 *Examination Before Testing*—The manifold shall be examined visually to determine conformance with the ordering data, interface dimensions, and workmanship without disassembly.

S1.1.2 *Relief-Valve Accumulation Test*—The pressure-relief valve shall be tested for two conditions of accumulation capacity: (i) full-open pressure-reducing valve and (ii) full-open bypass valve. Maximum inlet operating pressure shall be maintained at the manifold inlet during this test. For the pressure-reducing valve portion, close the bypass valve, and block or otherwise modify the pressure-reducing valve to the wide-open fail condition. For the bypass valve portion, the pressure-reducing valve shall be isolated and the bypass valve fully opened. Under either condition, downstream pressure rise shall not exceed the accumulation pressure specified in Specification F 1508.

S1.1.3 *Bypass Throttle Valve Functional Test*—Minimum inlet operating pressure shall be maintained at manifold inlet. The pressure-reducing valve shall be isolated. The bypass throttle valve shall be opened until highest set pressure is maintained at maximum flow rate demand. Increase inlet pressure to maximum, then vary flow demand throughout the flow range of the manifold and verify ability of the bypass throttle valve to permit maintaining delivered pressure at the set point in a smooth, accurate manner.

S1.1.4 *Bypass Throttle Valve Cycle Test*—With maximum inlet pressure operating upstream, the bypass throttle valve shall be cycled 100 times. There shall be no degradation to performance or evidence of damage or excessive wear. A cycle shall consist of a full opening and closing of the valve.

S1.1.5 *Pressure Reversal Test*—The manifold shall be tested to determine the susceptibility to damage when subjected to pressure reversal as specified in 6.5.1.1. It shall be set up with maximum inlet operating pressure and maximum set pressure. A separate means shall be included to insure that there is no loss of downstream pressure during this test. The reference load shall then be removed from the pressure-reducing valve set-point mechanism (if the pressure-reducing valve is spring loaded, all spring compression shall be backed off, if it is gas dome loaded, all dome charge shall be released). The inlet pressure shall then be released from the manifold, and this condition (no load on the pressure-reducing valve set point

mechanism, zero pressure applied to the inlet side of the pressure-reducing valve seat, and maximum set pressure applied to the outlet side of the pressure-reducing valve seat) shall be maintained for a period of not less than 1 h. There shall be no leakage from the outlet to the inlet of the manifold. There shall be no evidence of damage to the pressure-reducing valve or any other portion of the manifold and no degradation to the performance capability of the manifold.

S1.1.6 *Accuracy of Regulation Test*—The manifold shall be tested for accuracy of regulation at each inlet pressure/set pressure combination defined below. At Condition D, flow shall be varied over the full range of flow rate demand as specified in Section 5. For Conditions A, B, and C, full-flow range testing is not required.

Condition	Inlet Pressure	Set Pressure
A	maximum	minimum
B	minimum	minimum
C	maximum	maximum
D	minimum	maximum

During each sequence (changing from Condition A to Condition B and changing from Condition C to Condition D), no alteration shall be made to the set pressure adjustment, or any other portion of the manifold, and the accuracy of regulation shall be maintained as required by Table 4. There shall be no instability or other evidence of unsatisfactory operation of the manifold during these tests. Flow in each condition shall be maintained long enough to demonstrate that the above requirements are met.

S1.1.7 *Pressurization Rate Test*—With the rated inlet pressure upstream, and a depressurized downstream volume as specified in 6.5.3.5, each handwheel-operated valve shall be operated to demonstrate its ability to meet the pressurization rate as specified in 6.5.3.5.

S1.1.8 *Shock Test*—The manifold shall be subjected to and meet the high-impact shock tests for Grade A, Class I as specified in MIL-S-901 pressurized with water, air, or nitrogen. The inlet port shall be pressurized to the maximum inlet operating pressure and the outlet port pressurized to the maximum outlet operating pressure. There shall be no structural damage to the manifold or any components. There shall be no degradation to the performance capability of the manifold. Momentary loss in pressure is permissible.

S1.1.9 *Vibration Test*—The manifold shall be vibration tested in accordance with Type I of MIL-STD-167-1 pressurized with air or nitrogen. The inlet port shall be pressurized to the maximum inlet operating pressure and the outlet port pressurized to the maximum outlet operating pressure. At frequencies up to and including 33 Hz (unless otherwise specified in the ordering information, Section 5), there shall be

no resonance in the range of frequency tested. There shall be no structural damage or degradation to the performance capability of the manifold.

S1.1.10 *Noise Test*—The manifolds shall be tested for airborne noise in accordance with MIL-STD-740-1. The noise (sound pressure level) shall not exceed 85 dBA observed at 1-m distance from the manifold.

S1.1.11 *Posttest Examination*—The manifold shall be disassembled and examined for any evidence of excessive wear, degradation, or impending damage or breakage.

S2. Technical Data and Certification Requirements

S2.1 *Drawings*—Assembly drawings of the entire manifold and each component which clearly depict design shall be provided. The following shall also be included as part of the drawings content:

S2.1.1 Bill of material listing specification, grade, condition, and any other data required to identify fully the properties of the materials proposed. This shall include identifications, material and size designations, shore hardness, and any other data necessary to identify the parts fully.

S2.1.2 In cases in which standard commercial or military parts are or can be used, these shall be appropriately identified.

S2.1.3 Outline dimensions, disassembly space, location, and size of end connections and mounts.

S2.1.4 Estimated weight and center of gravity (vertical, longitudinal, and transverse).

S2.1.5 Recommended assembly torques or equivalent procedures for making up all joints and threaded assemblies.

S2.1.6 The following information shall be included:

S2.1.6.1 *Regulation*:

(a) Set pressure and adjustable range.

(b) Specified operating conditions—range of inlet pressures and required range of capacity.

(c) Fail-open capacity (for purposes of pressure-relief valve sizing) of the pressure-reducing valve.

(d) Wide-open capacity (for purposes of pressure-relief valve sizing) of bypass throttle valve.

S2.1.6.2 *Overpressure Protection for Pressure-Relief Valve*:

(a) Set pressure and adjustable range.

(b) Rated capacity—accumulation.

(c) Reset pressure.

S2.2 *Technical Manuals*—The following shall be included as part of the manual contents:

S2.2.1 The assembly drawings for the manifold, supplemented by additional illustrations where necessary to illustrate operation and maintenance adequately. These additional illustrations may consist of blowouts or partial or full sections and may eliminate extraneous lines and details to clarify the interaction of parts.

S2.2.2 Table listing wrench sizes and assembly torques (or other equivalent procedures) for making up all joints and threaded assemblies.

S2.2.3 Detailed disassembly and reassembly procedures. In addition to a section providing procedures for the complete disassembly and reassembly of the manifold, maintenance and troubleshooting sections shall contain, or refer to, only the limited disassembly and reassembly required to accomplish each particular operation. This is intended to reduce the

possibility of unnecessary disassembly and unnecessary disturbance of adjustments when performing specific or limited maintenance or troubleshooting operations.

S2.2.4 Adjustment procedures for the pressure-reducing and pressure-relief valve. For the pressure-relief valve, provide the approximate relationship between turns of the adjusting screw and set pressure change.

S2.3 *Certification*—Certification shall be provided indicating that the valve meets all requirements of the purchase order.

S3. Quality Assurance

S3.1 *Scope of Work*—The written description of the quality assurance system shall include the scope and locations of the work to which the system is applicable.

S3.2 *Authority and Responsibility*—The authority and responsibility of those in charge of the quality assurance system shall be clearly established.

S3.3 *Organization*—An organizational chart showing the relationship between management and the engineering, purchasing, manufacturing, construction, inspection, and quality control groups is required. The purpose of this chart is to identify and associate the various organizational groups with the particular functions for which they are responsible. These requirements are not intended to encroach on the manufacturer's right to establish, and from time to time to alter, whatever form of organization the manufacturer considers appropriate for its work. Persons performing quality control functions shall have a sufficiently well-defined responsibility and the authority and the organizational freedom to identify quality control problems and to initiate, recommend, and provide solutions.

S3.4 *Review of Quality Assurance System*—The manufacturer shall ensure and demonstrate the continuous effectiveness of the quality assurance system.

S3.5 *Drawings, Design Calculations, and Specification Control*—The manufacturer's quality assurance system shall include provisions to ensure that the latest applicable drawings, design calculations, specifications, and instructions, including all authorized changes, are used for manufacture, examination, inspection, and testing.

S3.6 *Purchase Control*—The manufacturer shall ensure that all purchased material and services conform to specified requirements and that all purchase orders give full details of the material and services ordered.

S3.7 *Material Control*—The manufacturer shall include a system for material control that ensures the material received is properly identified and that any required documentation is present, identified to the material, and verifies compliance to the specified requirements. The material control system shall ensure that only the intended material is used in manufacture. The manufacturer shall maintain control of material during the manufacturing process by a system that identifies status of material throughout all stages of manufacture.

S3.8 *Manufacturing Control*—The manufacturer shall ensure that manufacturing operations are carried out under controlled conditions using documented work instructions. The manufacturer shall provide for inspection, where appropriate, for each operation that affects quality or shall arrange an appropriate monitoring operation.

S3.9 *Quality Control Plan*—The manufacturer’s quality control plan shall describe the fabrication operations, including examinations and inspections.

S3.10 *Welding*—The quality control system shall include provisions for ensuring that welding conforms to specified requirements. Welders shall be qualified to the appropriate standards and the qualification records shall be made available to the inspection authority if required.

S3.11 *Nondestructive Examination*—Provisions shall be made to use nondestructive examination, as necessary, to ensure that material and components comply with the specified requirements. Nondestructive examinations shall be authorized by their employer or qualified by a recognized national body or both, and their authorizations/qualification records shall be made available to the inspection authority if required.

S3.12 *Nonconforming Items*—The manufacturer shall establish procedures for controlling items not in conformance with the specified requirements.

S3.13 *Heat Treatment*—The manufacturer shall provide controls to ensure that all required heat treatments have been applied. Means should be provided by which heat treatment requirements can be verified.

S3.14 *Inspection Status*—The manufacturer shall maintain a system for identifying the inspection status of material during all stages of manufacture and shall be able to distinguish between inspected and noninspected material.

S3.15 *Calibration of Measurement and Test Equipment*—The manufacturer shall provide, control, calibrate, and maintain inspection, measuring, and test equipment to be used in verifying conformance to the specified requirements. Such calibration shall be traceable to a national standard and calibration records shall be maintained.

S3.16 *Records Maintenance*—The manufacturer shall have a system for the maintenance of inspection records, radiographs, and manufacturer’s data reports that describe the achievement of the required quality and the effective operation of the quality system.

S3.17 *Sample Forms*—The forms used in the quality control system and any detailed procedures for their use shall be available for review. The written description of the quality assurance system shall make reference to these forms.

S3.18 *Inspection Authority*—The manufacturer shall make available to the inspection authority at the manufacturer’s plant a current copy of the written description of the quality assurance system. The manufacturer’s quality assurance system shall provide for the inspection authority at the manufacturer’s plant to have access to all drawings, calculations, specifications, procedures, process sheets, repair procedures, records, test results, and any other documents as necessary for the inspection authority to perform its duties in accordance with this supplementary requirement. The manufacturer may provide for such access by furnishing the inspection authority with originals or copies of such documents.

S4. Special Material, Design, and Performance Considerations

S4.1 *Recovered Materials*—Unless otherwise specified herein, all equipment, material, and articles incorporated in the products covered by this specification shall be new and may be fabricated using materials produced from recovered materials to the maximum extent practicable without jeopardizing the intended use. The term “recovered materials” means materials that have been collected or recovered from solid waste and reprocessed to become a source of raw materials, as opposed to virgin raw materials. None of the above shall be interpreted to mean that the use of used or rebuilt products is allowed under this specification unless otherwise specified.

S4.2 Pipe threads shall not be used in the manifold.

S4.3 Manifold performance shall not be adversely affected by the following line and ambient conditions:

S4.3.1 *Ambient Atmospheric Conditions*:

S4.3.1.1 Temperature: 40 to 120°F (4 to 49°C).

S4.3.1.2 Moisture content: Exposure to atmosphere containing salt-laden moisture.

S4.3.2 *Quality of Inlet Air/Gas*—Air or nitrogen moisture content between the limits of +20°F (−7°C) to −60°F (−50°C) dewpoint at 4500-psig (31.0-MPa gage pressure). Particulate contamination: Protected by 5-μm nominal/18-μm absolute filtration.

S4.4 *Gage Connections*—The ¼-in. (DN8) threaded gage connection (see 6.4.7) shall be in accordance with MS 16142.

ASTM International takes no position respecting the validity of any patent rights asserted in connection with any item mentioned in this standard. Users of this standard are expressly advised that determination of the validity of any such patent rights, and the risk of infringement of such rights, are entirely their own responsibility.

This standard is subject to revision at any time by the responsible technical committee and must be reviewed every five years and if not revised, either reapproved or withdrawn. Your comments are invited either for revision of this standard or for additional standards and should be addressed to ASTM International Headquarters. Your comments will receive careful consideration at a meeting of the responsible technical committee, which you may attend. If you feel that your comments have not received a fair hearing you should make your views known to the ASTM Committee on Standards, at the address shown below.

This standard is copyrighted by ASTM International, 100 Barr Harbor Drive, PO Box C700, West Conshohocken, PA 19428-2959, United States. Individual reprints (single or multiple copies) of this standard may be obtained by contacting ASTM at the above address or at 610-832-9585 (phone), 610-832-9555 (fax), or service@astm.org (e-mail); or through the ASTM website (www.astm.org).