



Standard Practice for Selection and Application of Thermal Insulation for Piping and Machinery¹

This standard is issued under the fixed designation F 683; the number immediately following the designation indicates the year of original adoption or, in the case of revision, the year of last revision. A number in parentheses indicates the year of last reapproval. A superscript epsilon (ϵ) indicates an editorial change since the last revision or reapproval.

This standard has been approved for use by agencies of the Department of Defense.

1. Scope

1.1 This practice provides guidance in the selection of types and thicknesses of thermal insulation materials for piping, machinery, and equipment for nonnuclear shipboard applications. Methods and materials for installation, including lagging, are also detailed.

1.2 Supplemental requirements and exceptions to the requirements discussed herein for ships of the U.S. Navy are included in Supplementary Requirements S1.

1.3 Asbestos or asbestos-containing materials shall not be used.

1.4 The values stated in inch-pound units are to be regarded as the standard. The values given in parentheses are for information only.

1.5 *This standard does not purport to address all of the safety concerns, if any, associated with its use. It is the responsibility of the user of this standard to establish appropriate safety and health practices and determine the applicability of regulatory limitations prior to use.*

2. Referenced Documents²

2.1 ASTM Standards:

A 167 Specification for Stainless and Heat-Resisting Chromium-Nickel Steel Plate, Sheet, and Strip³

A 653/A 653M Specification for Steel Sheet, Zinc-Coated (Galvanized) or Zinc-Iron Alloy-Coated (Galvannealed) by the Hot Dip Process⁴

B 209 Specification for Aluminum and Aluminum-Alloy Sheet and Plate⁵

B 209M Specification for Aluminum and Aluminum-Alloy Sheet and Plate [Metric]⁵

C 168 Terminology Relating to Thermal Insulating Materials⁶

C 195 Specification for Mineral Fiber Thermal Insulating Cement⁶

C 449/C449M Specification for Mineral Fiber Hydraulic-Setting Thermal Insulating and Finishing Cement⁶

C 533 Specification for Calcium Silicate Block and Pipe Thermal Insulation⁶

C 534 Specification for Preformed Flexible Elastomeric Cellular Thermal Insulation in Sheet and Tubular Form⁶

C 547 Specification for Mineral Fiber Pipe Insulation⁶

C 552 Specification for Cellular Glass Thermal Insulation⁶

C 553 Specification for Mineral Fiber Blanket Thermal Insulation for Commercial and Industrial Applications⁶

C 610 Specification for Molded Expanded Perlite Block and Pipe Thermal Insulation⁶

C 612 Specification for Mineral Fiber Block and Board Thermal Insulation⁶

C 680 Practice for Determination of Heat Gain or Loss and the Surface Temperatures of Insulated Pipe and Equipment Systems by the Use of a Computer Program⁶

C 892 Specification for High-Temperature Fiber Blanket Thermal Insulation⁶

C 1482 Specification for Polyimide Flexible Cellular Thermal and Sound Absorbing Insulation⁶

D 962 Specification for Aluminum Powder and Paste Pigments for Paints⁷

D 3400 Specification for Liquid Sodium Silicates⁸

F 1138 Specification for Spray Shields for Mechanical Joints⁹

2.2 Federal Specifications:¹⁰

HH-P-31 Packing and Lagging Material, Fibrous Glass Metallic and Plain Cloth and Tape

TT-P-28 Paint, Aluminum, Heat Resisting (1200°F)

2.3 Military Specifications:¹⁰

DoD-C-15328 Primer (Wash), Pretreatment (Formula No.

¹ This practice is under the jurisdiction of ASTM Committee F25 on Ships and Marine Technology and is the direct responsibility of Subcommittee F25.02 on Insulation/Processes.

Current edition approved Feb. 10, 2002. Published April 2002. Originally published as F 683 – 80. Last previous edition F 683 – 00.

² The latest revision of all referenced documents shall apply.

³ *Annual Book of ASTM Standards*, Vol 01.03.

⁴ *Annual Book of ASTM Standards*, Vol 01.06.

⁵ *Annual Book of ASTM Standards*, Vol 02.02.

⁶ *Annual Book of ASTM Standards*, Vol 04.06.

⁷ *Annual Book of ASTM Standards*, Vol 06.03.

⁸ Discontinued; see 2001 *Annual Book of ASTM Standards*, Vol 15.04.

⁹ *Annual Book of ASTM Standards*, Vol 01.07.

¹⁰ Available from Standardization Documents Order Desk, Bldg. 4 Section D, 700 Robbins Ave., Philadelphia, PA 19111-5094, Attn: NPODS.



- 117 for Metals) Metric
DoD-C-24596 Coating Compounds, Nonflaming, Fire-Protective (Metric)
DoD-E-24607 Enamel, Interior, Nonflaming (Dry), Chlorinated Alkyd Resin, Semigloss (Metric)
DoD-I-24688 Type I, Insulation, Polyimide, Sheet and Tube
MIL-A-3316 Adhesive, Fire-Resistant, Thermal Insulation
MIL-A-24179 Adhesive, Flexible, Unicellular-Plastic, Thermal Insulation
MIL-C-2861 Cement Insulation, High Temperature
MIL-C-19565 Coating Compounds, Thermal Insulation Pipe Covering—Fire and Water-Resistant Vapor Barrier and Weather Resistant
MIL-C-20079 Cloth, Glass, Tape, Textile Glass and Thread, Glass
MIL-C-22395 Compound, End Sealing, Thermal Insulation Pipe Covering—Fire, Water, and Weather Resistant
MIL-I-22023 Insulation Felt, Thermal and Sound Absorbing Felt, Fibrous Glass, Flexible
MIL-I-2781 Insulation, Pipe, Thermal
MIL-I-2818 Insulation Blanket, Thermal, Fibrous Material
MIL-I-2819 Insulation, Block, Thermal
MIL-I-16411 Insulation, Felt, Thermal, Glass Fiber
MIL-I-22344 Insulation, Pipe, Thermal, Fibrous Glass
MIL-P-15280 Plastic Material, Unicellular (Sheets and Tubes)
MIL-STD-769 Thermal Insulation Requirements for Machinery and Piping
MIL-STD-2118 Trap, Steam, Angle, Thermostatic
2.4 *Other Documents:*
Title 46 Code of Federal Regulations (CFR), Shipping (Parts 164.009 and 164.012)¹⁰
Electric Boat Specification 4013 Anti-Sweat and Refrigerant Insulation (Sheet and Tubes)¹¹
2.5 *Drawings, NAVSHIP:*
804-5959214 Piping Insulation, Installation Details¹²
804-5959212 Machinery Insulation, Installation Details¹²
2.6 *NAVSEA:*
Naval Ships Technical Manual, Chapter 635—Thermal, Fire, and Acoustic Insulation¹⁰
803-5184182 Passive Fire Protection Insulation¹⁰

3. Terminology

3.1 *Definitions*—For definitions of terms relating to insulating materials used in this practice, refer to Terminology C 168.

4. Materials and Manufacture

4.1 *Insulation and Lagging Material Specifications*, as listed in Tables 1-17, describe those materials that are intended for use in the indicated temperature ranges. The specifications and requirements outlined herein are not intended to prevent the use of new test methods or materials, provided that sufficient technical data is submitted to demonstrate that the

proposed test method or material is equivalent in quality, effectiveness, durability, and safety to that prescribed by this practice.

5. General Requirements

5.1 Piping, including valves, fittings, and flanges conveying vapors, gases, or liquids that attain temperatures outside the range from 55 to 125°F (13 to 52°C) during normal operation, shall be insulated except as otherwise stated herein.

5.2 The insulation thicknesses specified in this practice are designed to maintain the surface temperature at or below 125°F (52°C) for fluid temperatures up to 650°F (343°C) with an ambient temperature of 85°F (29°C). For fluid temperatures above 650°F, the surface will be maintained at a maximum of 133°F (56°C).

5.2.1 Insulation thicknesses have been calculated in accordance with the computer programs in Practice C 680.

5.3 Piping and units of equipment with designated internal temperatures of 300°F (149°C) and over shall be insulated from their supports or the supports insulated from the structures to which they are attached where the heat transmitted may be objectionable on the opposite side of the structure.

5.4 Insulated piping passing through accommodation, service, and control spaces must be covered with approved incombustible materials which meet 46 CFR, Sections 164.009 and 164.012. Elastomeric foam plastic insulation shall not be used in these spaces.

5.5 Special consideration shall be given to the insulation of integral piping supplied with and mounted on equipment or machinery. In these cases, alternative materials and methods of installation may be considered provided that they comply with the performance requirements of this practice.

5.6 Minimum insulation requirements have not been established for those surfaces or applications in which insulations had not been specified in past practices. In effect, the following surfaces are excluded from insulation requirements:

5.6.1 Surfaces where application of insulation would affect proper operation.

5.6.2 Equipment, components, and systems designed for the dispersion of heat.

5.6.3 Thermostatic steam traps and 24 in. (620 mm) of piping upstream of traps, which shall not be insulated. When located in areas in which personnel protection is required, expanded metal shields or multilayer glass cloth shall be provided.

5.6.4 Mechanical joints exposed to subatmospheric pressures and those included in the fuel oil service piping from heaters to burners.

5.6.5 Fuel oil piping between headers and burners.

5.6.6 Piping above 125°F (52°C) in bilges, not within watertight enclosures.

5.6.7 Piping in locations in which sweating and possible resultant rust is not objectionable such as voids, bilges, and shaft alleys, plus plumbing fixtures and associated supply and drain piping immediately adjacent thereto.

5.6.8 Deadend hot water piping $\frac{3}{8}$ in. (10 mm) and smaller.

5.6.9 Pressure-gage piping.

5.6.10 Soot-blower valve units and soot-blower flanges.

¹¹ Available from Electric Boat Corp., 75 Eastern Point Rd., Groton, CT 06340.

¹² Available from U.S. Government Printing Office.



TABLE 1 Insulation and Lagging Materials for Pipe, Tubing, and Fittings Used for Interior Piping Systems^{A,B}

Temperature Range °F (°C)	Insulation	Specification	Lagging ^C	Specification
-20 to +40 (-29 to +4)	cellular glass	C 552, Type II	fibrous glass cloth	MIL-C-20079, Type I, Classes 3 through 9 commercial
	polyimide foam ^D	C 1482, Type I, with vapor retarder	sheet steel galvanized fibrous glass cloth	MIL-C-20079, Type I, Classes 3 through 9
	elastomeric foam plastic ^A	MIL-P-15280, Form T	fibrous glass cloth	MIL-C-20079, Type I, Classes 3 through 9
41 to 125 (5 to 51)	cellular glass	C 552, Type II	fibrous glass cloth	MIL-C-20079, Type I, Classes 3 through 9 commercial
	polyimide foam	C 1482, Type I, with vapor retarder	sheet steel galvanized fibrous glass cloth	MIL-C-20079, Type I, Classes 3 through 9
	elastomeric foam plastic ^A	MIL-P-15280, Form T	fibrous glass cloth	MIL-C-20079, Type I, Classes 3 through 9
	mineral fiber ^D	C 547, Type II	fibrous glass cloth	MIL-C-20079, Type I, Classes 3 through 9 commercial
126 to 450 (52 to 232)	cellular glass	C 552, Type II	sheet steel galvanized fibrous glass cloth	MIL-C-20079, Type I, Classes 3 through 9 commercial
	polyimide foam ^E 400°F (204°C) max	C 1482, Type I	fibrous glass cloth	MIL-C-20079, Type I, Classes 3 through 9
	elastomeric foam plastic ^A 180°F (82°C) max	MIL-P-15280, Form T	fibrous glass cloth	MIL-C-20079, Type I, Classes 3 through 9 commercial
	calcium silicate	C 533	sheet steel galvanized fibrous glass cloth	MIL-C-20079, Type I, Classes 3 through 9 commercial
	expanded perlite	C 610	sheet steel galvanized fibrous glass cloth	MIL-C-20079, Type I, Classes 3 through 9 commercial
451 to 1050 (233 to 566)	cellular glass, 800°F (427°C) max	C 552, Type II	sheet steel galvanized fibrous glass cloth	MIL-C-20079, Type I, Classes 3 through 9 commercial
	mineral fiber	C 547, Class 2 (850°F [454°C] max) or Class 3	sheet steel galvanized sheet steel black	commercial
	calcium silicate	C 533	sheet steel black	commercial
	expanded perlite	C 610	sheet steel black	commercial

^ASee 5.4.

^BInsulation and lagging materials are acceptable for the temperature ranges indicated; other materials may be used provided the requirements of this practice are satisfied. Thermal insulating tape may be used as allowed by Section 8 of this practice.

^CLagging is to be used over insulation only.

^DSee Supplementary Requirements S1.5.

^ESee Supplementary Requirements S1.15.

5.6.11 Piping in voids and cofferdams except where omitting insulation may be detrimental to system operation, such as catapult steam.

5.6.12 Safety valve bodies, springs, and lifting gear.

5.6.13 Piping over shower stalls and behind and under lavatories.

5.6.14 Valves or flanges in the collection holding tank (CHT) system.

5.7 Higher-temperature-type insulations may be used where lower-temperature-type insulations are specified, provided that they are satisfactory in all other respects.

5.8 In “high traffic” locations in which the completed insulation and lagging is liable to abuse, such as shipping, unshipping, and maintenance areas, protective sheet metal lagging should be installed. Where metal lagging is required, any of the materials listed in Table 13 are acceptable, except for boiler uptake applications in which metal lagging shall be galvanized sheet steel, in accordance with Specification A 653/A 653M, with Coating Designation G-115, and not less than 1/32 in. (0.8 mm) thick.

5.9 Before installing insulation, surface preparation of the piping is to be accomplished in accordance with the ship’s painting schedule.

5.10 Lacing hooks should be welded to the structure or equipment (with permission of the vendor of the equipment) for securing insulation to the equipment.

5.11 For bends, fittings, and so forth, where molded sections of pipe insulation cannot be used, mitered sections of the pipe insulation or premolded fittings and covers may be used, provided that they are suitable for the temperature and that the requirements of this practice are satisfied (see 4.1 and 5.4). Fittings in sizes under 2-in. (51-mm) nominal pipe size (NPS) may be insulated with insulating cement, in accordance with Specification C 449/C 449M.

5.12 Where insulation specifications listed in Tables 1 and 3 provide for the use of nonmetal “jacketed”-type insulation, separate lagging material may be omitted.

5.13 Single-layered insulation construction shall be permitted on all surfaces operating at temperatures below 600°F (316°C). Double-layered insulation construction shall be used with all joints staggered on all surfaces operating at temperatures of 600°F and above, except single-layered construction will be permitted when the total insulation thickness is 3 in. (75 mm) or less or the pipe size is NPS 2 in. (50 mm) or below.



TABLE 2 Insulation and Lagging Materials for Pipe, Tubing, and Fittings Used for Weather-Exposed Piping Systems^A

Temperature Range ° F (°C)	Insulation	Specification	Lagging ^B	Specification
-20 to +40 (-29 to +4)	cellular glass	C 552, Type II	fibrous glass cloth	MIL-C-20079, Type I Class 7 (fittings) Class 9 (piping)
	polyimide foam	C 1482, Type I, with vapor retarder	fibrous glass cloth	MIL-C-20079, Type I Class 7 (fittings) Class 9 (piping)
	perlite	C 610	fibrous glass cloth	MIL-C-20079, Type I Class 7 (fittings) Class 9 (piping)
41 to 100 (5 to 37)	cellular glass	C 552, Type II	corrosion-resistant steel	A 167, Type 304
	polyimide foam	C 1482, Type I, with vapor retarder	fibrous glass cloth	MIL-C-20079, Type I Class 7 (fittings) Class 9 (piping)
	perlite	C 610	corrosion-resistant steel	A 167, Type 304
	calcium silicate	C 533	corrosion-resistant steel	A 167, Type 304
	mineral fiber ^C	C 547, Class 2 or 3	corrosion-resistant steel	A 167, Type 304
101 to 450 (38 to 232)	cellular glass	C 552, Type II	corrosion-resistant steel	A 167, Type 304
	polyimide foam ^B 400°F (204°C) max	C 1482, Type I	corrosion-resistant steel	A 167, Type 304
	perlite	C 610	corrosion-resistant steel	A 167, Type 304
	calcium silicate	C 533	corrosion-resistant steel	A 167, Type 304
	mineral fiber ^C	C 547, Class 2 or 3	corrosion-resistant steel	A 167, Type 304

^AInsulation and lagging materials listed are acceptable for the temperature ranges indicated; other materials may be used provided the requirements of this practice are satisfied.

^BSee Supplementary Requirements S1.15.

^CSee Supplementary Requirements S1.5.

6. Selection Requirements, Piping

6.1 *Interior Piping, Temperature Range from -20 to +40°F (-29 to +4°C)*—Use for air conditioning and ship's stores refrigerant piping and other services within the temperature range.

6.1.1 For insulation and lagging materials, see Table 1.

6.1.2 For insulation thickness, see Table 4 or Table 5.

6.1.3 For installation details, see Fig. 1, Fig. 2, or Fig. 3 as applicable.

6.2 *Interior Piping, Temperature Range from 41 to 125°F (5 to 52°C)*—Use for cold freshwater, plumbing drains, firemain, main and auxiliary, saltwater circulating, and saltwater cooling, piping, and other services within the temperature range.

6.2.1 For insulation and lagging materials, see Table 1.

6.2.2 For insulation thickness, see Table 2, Table 3, or Table 4.

6.2.3 For installation details, see Fig. 1, Fig. 2, or Fig. 3 as applicable.

6.2.4 *Special Conditions:*

6.2.4.1 Piping systems operating in this temperature range including water closet drain piping do not require insulation except where damage or discomfort may result from condensation.

6.2.4.2 Dry firemain need only be insulated above ceilings and in areas in which damage or discomfort may be realized from condensation.

6.2.4.3 If cold, fresh, or potable water tanks (not having a side integral with the shell) are installed in a heated area, the piping to the pumps and therefore to the services need not be insulated. If this water is being used for flushing water closets, the drain piping need not be insulated.

6.2.4.4 Freshwater fill piping inside the ship shall be insulated.

6.2.4.5 Drains from drinking water chillers shall be insulated.

6.3 *Interior Piping, Temperature Range from 126 to 450°F (52 to 232°C)*—Use for hot freshwater, hot-water heating, fuel oil service discharge from heaters to headers, condensate, and air ejector piping, boiler feed, high- and low-pressure steam drain piping, and other services within the temperature range.

6.3.1 For insulation and lagging materials, see Table 1.

6.3.2 For insulation thickness, see Table 4, Table 5, Table 7, Table 8, or Table 9.

6.3.3 For installation details, see Fig. 1, Fig. 2, Fig. 3, Fig. 4, Fig. 5, or Fig. 6, as applicable.

6.3.4 *Special Conditions*—On piping, tubing, and fittings sized less than NPS 3/8 in., insulation need be applied only where required for personnel protection.

6.4 *Interior Piping, Temperature Range from 451 to 1200°F (233 to 649°C)*—Use for main steam, auxiliary steam, exhaust and bleed steam, gland seal steam and exhaust, high- and low-pressure steam drains, soot blower steam, boiler blow,



TABLE 3 Insulation and Lagging Materials for Machinery and Equipment^{A,B}

Temperature Range °F (°C)	Insulation	Specification	Lagging	Specification
-20 to +40 (-29 to +4)	elastomeric foam plastic ^A	MIL-P-15280, Form S	fibrous glass cloth	MIL-C-20079, Type I, Classes 3 through 9
	polyimide foam	C 1482, Type I	fibrous glass cloth with vapor retarder	MIL-C-20079 Type I, Classes 3 through 9
	cellular glass	C 552, Type II	sheet steel galvanized	commercial ^C
41 to 125 (5 to 51)	elastomeric foam plastic ^A	MIL-P-15280, Form S	fibrous glass cloth	MIL-C-20079, Type I, Classes 3 through 9
	polyimide foam	C 1482, Type I	fibrous glass cloth with vapor retarder	MIL-C-20079, Type I, Classes 3 through 9
	cellular glass	C 552, Type I	fibrous glass cloth, or sheet steel black commercial	MIL-C-20079, Type I, Classes 3 through 9 commercial ^C
	mineral fiber blanket	C 553	sheet steel black, commercial or fibrous glass cloth with vapor retarder	MIL-C-20079, Type I, Classes 3 through 9 commercial ^C
126 to 1200 (52 to 649)	fibrous glass felt	MIL-I-16411, Type II	fibrous glass cloth glass wire, reinforced	MIL-C-20079, Type I, Classes 7 or 9 HH-P-31, Type I
	polyimide foam ^D 400°F (204°C) max	C 1482, Type I	fibrous glass cloth	MIL-C-20079, Type I, Classes 3 through 8
	refractory fiber blanket	C 892, Grade 6 or 8	sheet steel black commercial or fibrous glass cloth glass wire, reinforced	MIL-C-20079, Type I, Classes 3 through 9 HH-P-31, Type I
	elastomeric foam plastic (180°F [82°C] max)	MIL-P-15280 sheet	fibrous glass cloth	MIL-C-20079, Type I, Classes 3 through 9
	high-temperature insulating cement ^E	C 195		
	calcium silicate insulating block	C 553		
	mineral fiber blanket (1000°F [538°C] max)	C 553, C 612	sheet steel black, or fibrous glass cloth glass wire, reinforced	MIL-C-20079, Type I, Classes 3 through 9 HH-P-31, Type I
	perlite	C 610	fibrous glass cloth	MIL-C-20079, Type I, Classes 3 through 9

^ASee 5.4.

^BInsulation and lagging materials are acceptable for the temperature ranges indicated; other materials may be used provided the requirements of this practice are satisfied.

^CWith or without rewettable adhesive.

^DSee Supplementary Requirements S1.15.

^EWhen insulating cement is used, it shall be applied in successive layers, ½ to 1 in. (13 to 25 mm) in thickness, until the total thickness specified in Table 7 has been reached. Galvanized iron wire netting, 1-in. (13-mm) mesh, shall be installed between layers. A ½-in. (13-mm) thickness of finishing cement, in accordance with Specification C 449/C 449M, shall be applied over the last layer of insulating cement.

safety and relief valve escape steam heating, diesel exhaust piping, and other services within the temperature range.

6.4.1 For insulation and lagging materials, see Table 1.

6.4.2 For insulation thickness, see Table 4, Table 7, Table 8, or Table 9, as applicable.

6.4.3 For installation details, see Fig. 1, Fig. 4, Fig. 5, or Fig. 6, as applicable.

6.4.4 *Special Conditions:*

6.4.4.1 The soot blower piping between the root valve and the soot blower heads shall have an insulation thickness of one half of that indicated for a continually operating system at the same temperature.

6.4.4.2 Main steam piping insulation shall be arranged with

removable pads to bare sections for audio gaging when required.

6.4.4.3 Turbogenerator exhaust to main and auxiliary condensers do not require insulation except in areas susceptible to personnel contact.

6.4.4.4 Safety and relief valve escape piping need not be insulated except in areas susceptible to contact by personnel.

6.4.4.5 Boiler blow piping need not be insulated except in areas susceptible to contact by personnel.

6.4.4.6 On piping, tubing, and fittings sizes less than NPS ¾ in. (10 mm), insulation need be applied only where required for personnel protection.

6.4.4.7 Steam smothering and steam to the sea chests need



TABLE 4 Thickness of Cellular Glass Insulation for Piping, -20 to 800°F (-29 to 427°C)^A

Nominal Pipe Size, in. (mm)	Maximum Temperature, °F (°C) × Thickness, in. (mm)								
	-20 to 40 ^B (-29 to 4)	41 to 125 ^C (5 to 52)	250 (121)	350 (177)	450 (232)	550 (288)	650 (343)	750 (399)	850 (454)
¼ (6) and above	2½ (63) 1½ ^D (38)	1 (25) ½ ^D (13)
1½ (38) and below	1 (25)	1 (25)	1½ (38)	2 (51)	2½ (63)	2½ (63)	3 (76)
2 (51)	1 (25)	2 (51)	1½ (38)	2 (51)	3 (76)	3 (76)	3½ (89)
2½, 3 (63, 76)	1 (25)	1½ (38)	2 (51)	2½ (63)	3 (76)	3½ (89)	4 (102)
4 (102)	1 (25)	1½ (38)	2 (51)	2½ (63)	3½ (89)	3½ (89)	4 (102)
5, 6 (127, 152)	1 (25)	1½ (38)	2 (51)	3 (76)	3½ (89)	3½ (89)	4½ (114)
8 (203)	1½ (38)	1½ (38)	2 (51)	3 (76)	3½ (89)	4 (102)	5 (127)
10 (254)	1½ (38)	1½ (38)	2 (51)	3 (76)	4 (102)	4 (102)	5 (127)
12 (305)	1½ (38)	1½ (38)	2½ (63)	3 (76)	4 (102)	4½ (114)	5½ (140)
14 (356)	1½ (38)	1½ (38)	2½ (63)	3½ (89)	4 (102)	4½ (114)	5½ (140)
16 (406)	1½ (38)	1½ (38)	2½ (63)	3½ (89)	4½ (114)	4½ (114)	5½ (140)
18 (457)	1½ (38)	1½ (38)	2½ (63)	3½ (89)	4½ (114)	4½ (114)	5½ (140)

^AThickness of cellular glass, in accordance with Specification C 552, Type II.

^BFor refrigerant piping.

^CFor antisweat applications.

^DThickness for applications in air-conditioned spaces only.

TABLE 5 Thickness of Elastomeric Foam Plastic Insulation Piping, -20 to 180°F (-29 to 82°C)^A

Nominal Size, in. (mm)	Temperature Range, °F (°C)	Nominal Thickness, in. (mm)	
¼ (6) and above	-20 to 40 (-29 to 4) ^B	1½ (38)	1 (25) ^C
	41 to 125 (5 to 52) ^D	¾ (19)	½ (13) ^C
	126 to 180 (53 to 82)	½ (13)	½ (13) ^C

^AThickness of elastomeric foam plastic insulation, conforming with MIL-P-15280, Form T.

^BFor refrigerant piping.

^CFor antisweat applications.

^DThickness for applications in air-conditioned spaces only.

TABLE 6 Thickness of Polyimide Foam Insulation Piping, -20 to 400°F (-29 to 204°C)^A

Nominal Size, in. (mm)	Temperature Range, °F (°C)	Nominal Thickness, in. (mm)	
¼ (6) and above	-20 to 40 (-29 to 4) ^B	1½ (38)	1 (25) ^C
	41 to 125 (5 to 52) ^D	¾ (19)	½ (13) ^C
	126 to 180 (53 to 82)	½ (13)	
	181 to 250 (83 to 121)	¾ (19)	
	251 to 350 (122 to 177)	1 (25)	
	351 to 400 (178 to 204)	1½ (38)	

^AThickness of polyimide foam insulation conforming with Specification C 1482.

^BFor refrigerant piping.

^CFor antisweat applications.

^DThickness for applications in air conditioned spaces only.

be insulated only in those areas susceptible to personnel contact.

6.5 *Weather-Exposed Piping, Temperature Range from -20 to +40°F (-29 to +4°C)*—Use for low-temperature piping exposed to the weather.

6.5.1 For insulation and lagging materials, see Table 2.

6.5.2 For insulation thickness, see Table 4.

6.5.3 For installation details, see Fig. 3, Fig. 7, or Fig. 8.

6.5.4 *Special Conditions:*

6.5.4.1 Piping exposed to the weather should also be effectively insulated against freezing. The thickness of insulation required to prevent freezing is determined by calculation based on the system fluid, system velocity, type of insulation to be used, and climatic conditions involved. This does not apply to systems that are normally secured and drained.

TABLE 7 Thickness of Mineral Fiber Insulation for Hot Piping, 850°F (454°C) Maximum^{A,B}

Nominal Pipe Size, in. (mm)	Maximum Temperature, °F (°C) × Thickness, in. (mm)							
	150 (66)	250 (121)	350 (177)	450 (232)	550 (288)	650 (343)	750 (399)	850 (454)
1½ (38) and below	1 (25)	1 (25)	1 (25)	1½ (38)	2 (51)	2 (51)	2½ (63)	3 (76)
2 (51)	1 (25)	1 (25)	1 (25)	1½ (38)	2 (51)	2½ (63)	3 (76)	3½ (89)
2½, 3 (63, 76)	1 (25)	1 (25)	1 (25)	1½ (38)	2 (51)	3 (76)	3½ (89)	4 (102)
4 (102)	1 (25)	1 (25)	1 (25)	1½ (38)	2 (51)	3 (76)	3½ (89)	4 (102)
5, 6 (127, 152)	1 (25)	1 (25)	1 (25)	2 (51)	2½ (63)	3 (76)	3½ (89)	4 (102)
8 (203)	1 (25)	1 (25)	1 (25)	2 (51)	2½ (63)	3 (76)	3½ (89)	4½ (114)
10 (254)	1 (25)	1 (25)	1½ (38)	2 (51)	2½ (63)	3½ (89)	3½ (89)	4½ (114)
12 (305)	1 (25)	1 (25)	1½ (38)	2 (51)	2½ (63)	3½ (89)	4½ (114)	4½ (114)
14, 16, 18 (356, 406, 457)	1 (25)	1 (25)	1½ (38)	2 (51)	3 (76)	3½ (89)	4½ (114)	5 (127)

^ACommercially known as fibrous glass.

^BThickness of mineral fiber insulation in accordance with Specification C 547, Class 2.

6.5.4.2 At pipe supports, remove only enough insulation to provide a snug fit. Fill voids between insulation and support with tightly packed fibrous glass felt, conforming with MIL-I-16411, Type II, to within ¼ in. (6 mm) of the insulation surface. Fill the remainder with end-sealing compound, conforming with MIL-C-22395, overlapping both the support member and the adjacent insulation. Lag and coat with the same materials as the adjacent pipe.

6.6 *Weather-Exposed Piping, Temperature Range from 41 to 450°F (5 to 232°C)*—Use for hot piping systems exposed to weather.

6.6.1 For insulation and lagging materials, see Table 2.

6.6.2 For insulation thickness, see Table 4, Table 7, Table 8, or Table 9.

6.6.3 For installation details, see Fig. 3, Fig. 7, or Fig. 8.

6.6.4 *Special Conditions:*

6.6.4.1 Piping exposed to the weather should be effectively insulated against freezing. The thickness of insulation required



TABLE 8 Thickness of Mineral Fiber Insulation for Hot Piping, 1050°F (566°C) Maximum^{A,B}

Nominal Pipe Size, in. (mm)	Maximum Temperature, °F (°C) × Thickness, in. (mm)									
	150 (66)	250 (121)	350 (177)	450 (232)	550 (288)	650 (343)	750 (399)	850 (454)	950 (510)	1050 (566)
1½ (38) and below	1 (25)	1 (25)	1 (25)	1½ (38)	2 (51)	2 (51)	2 (51)	2½ (63)	3 (76)	3½ (89)
2 (51)	1 (25)	1 (25)	1 (25)	1½ (38)	2 (51)	2 (51)	2½ (63)	3 (76)	3½ (89)	4 (102)
2½, 3 (63, 76)	1 (25)	1 (25)	1 (25)	1½ (38)	2 (51)	2½ (63)	3½ (89)	3½ (89)	4 (102)	4½ (114)
4 (102)	1 (25)	1 (25)	1 (25)	1½ (38)	2 (51)	2½ (63)	3 (76)	3½ (89)	4 (102)	4½ (114)
5, 6 (127, 152)	1 (25)	1 (25)	1½ (38)	2 (51)	2½ (63)	3 (76)	3 (76)	3½ (89)	4½ (114)	5½ (140)
8 (203)	1 (25)	1 (25)	1½ (38)	2 (51)	2½ (63)	3 (76)	3 (76)	4 (102)	4½ (114)	5½ (140)
10 (254)	1 (25)	1 (25)	1½ (38)	2 (51)	2½ (63)	3 (76)	3½ (89)	4 (102)	5 (127)	6 (152)
12 (305)	1 (25)	1 (25)	1½ (38)	2 (51)	2½ (63)	3½ (89)	3½ (89)	4 (102)	5 (127)	6 (152)
14 (356)	1 (25)	1 (25)	1½ (38)	2 (51)	2½ (63)	3½ (89)	3½ (89)	4½ (114)	5½ (140)	6½ (165)
16 (406)	1 (25)	1 (25)	1½ (38)	2 (51)	3 (76)	3½ (89)	3½ (89)	4½ (114)	5½ (140)	6½ (165)
18 (457)	1 (25)	1 (25)	1½ (38)	2 (51)	3 (76)	3½ (89)	4 (102)	4½ (114)	5½ (140)	6½ (165)

^ACommercially known as mineral wool.

^BThickness of mineral fiber insulation, in accordance with Specification C 547, Class 3.

TABLE 9 Thickness of Calcium Silicate Insulation (Specification C 533) for Hot Piping, 1050°F (566°C) Maximum^A

Nominal Pipe Size, in. (mm)	Maximum Temperature, °F (°C) × Thickness, in. (mm)									
	150 (66)	250 (121)	350 (177)	450 (232)	550 (288)	650 (343)	750 (399)	850 (454)	950 (510)	1050 (566)
1½ (38) and below	1 (25)	1 (25)	1 (25)	1½ (38)	2 (51)	2½ (63)	2½ (63)	2½ (63)	3 (76)	3½ (89)
2 (51)	1 (25)	1 (25)	1 (25)	1½ (38)	2 (51)	2½ (63)	2½ (63)	3 (76)	3½ (89)	4 (102)
2½, 3, 4 (63, 76, 102)	1 (25)	1 (25)	1½ (38)	2 (51)	2½ (63)	3 (76)	3 (76)	3½ (89)	4 (102)	5 (127)
5, 6 (127, 152)	1½ (38)	1½ (38)	1½ (38)	2 (51)	2½ (63)	3½ (89)	3½ (89)	4 (102)	4½ (114)	5½ (140)
8 (203)	1½ (38)	1½ (38)	1½ (38)	2 (51)	2½ (63)	3½ (89)	3½ (89)	4 (102)	5 (127)	5½ (140)
10 (254)	1½ (38)	1½ (38)	1½ (38)	2 (51)	3 (76)	3½ (89)	3½ (89)	4½ (114)	5 (127)	6 (152)
12 (305)	1½ (38)	1½ (38)	1½ (38)	2 (51)	3 (76)	3½ (89)	3½ (89)	4½ (114)	5½ (140)	6 (152)
14 (356)	1½ (38)	1½ (38)	1½ (38)	2½ (63)	3 (76)	4 (102)	4 (102)	4½ (114)	5½ (140)	6½ (165)
16, 18 (406, 457)	1½ (38)	1½ (38)	1½ (38)	2½ (63)	3 (76)	4 (102)	4 (102)	5 (127)	5½ (140)	6½ (165)

^AThickness of calcium silicate insulation, in accordance with Specification C 533.

TABLE 10 Thickness of Perlite Insulation (Specification C 610) for Hot Piping, 1050°F (566°C) Maximum^A

Nominal Pipe Size, in. (mm)	Maximum Temperature, °F (°C) × Thickness, in. (mm)									
	150 (66)	250 (121)	350 (177)	450 (232)	550 (288)	650 (343)	750 (399)	850 (454)	950 (510)	1050 (566)
1½ (38) and below	1 (25)	1 (25)	1 (25)	1½ (38)	2 (51)	2½ (63)	2½ (63)	2½ (63)	3 (76)	3½ (89)
2 (51)	1 (25)	1 (25)	1 (25)	1½ (38)	2 (51)	2½ (63)	2½ (63)	3 (76)	3½ (89)	4 (102)
2½, 3, 4 (63, 76, 102)	1 (25)	1 (25)	1½ (38)	2 (51)	2½ (63)	3 (76)	3 (76)	3½ (89)	4 (102)	5 (127)
5, 6 (127, 152)	1½ (38)	1½ (38)	1½ (38)	2 (51)	2½ (63)	3½ (89)	3½ (89)	4 (102)	4½ (114)	5½ (140)
8 (203)	1½ (38)	1½ (38)	1½ (38)	2 (51)	2½ (63)	3½ (89)	3½ (89)	4 (102)	5 (127)	5½ (140)
10 (255)	1½ (38)	1½ (38)	1½ (38)	2 (51)	3 (76)	3½ (89)	3½ (89)	4½ (114)	5 (127)	6 (152)
12 (305)	1½ (38)	1½ (38)	1½ (38)	2 (51)	3 (76)	3½ (89)	3½ (89)	4½ (114)	5½ (140)	6 (152)
14 (356)	1½ (38)	1½ (38)	1½ (38)	2½ (63)	3 (76)	4 (102)	4 (102)	4½ (114)	5½ (140)	6½ (163)
16, 18 (406, 457)	1½ (38)	1½ (38)	1½ (38)	2½ (63)	3 (76)	4 (102)	4 (102)	5 (127)	5½ (140)	6½ (165)

^AThickness of perlite insulation, in accordance with Specification C 610.

to prevent freezing is determined by calculation based on the system fluid, system velocity, type of insulation to be used, and climatic conditions involved. This does not apply to systems that are normally secured and drained.

6.6.4.2 At pipe supports, remove only enough insulation to provide a snug fit. Fill voids between the insulation and support with tightly packed fibrous glass felt, conforming with MIL-I-16411, Type II, to within ¼ in. (6 mm) of the insulation surface. Fill the remainder with end-sealing compound, conforming with MIL-C-22395, overlapping both the support member and the adjacent insulation. Lag and coat with the same materials as the adjacent pipe.

7. Selection Requirements, Machinery and Equipment

7.1 *Temperature Range from -20 to +40°F (-29 to +4°C)*—Use for refrigerant and other equipment within the temperature range.

7.1.1 For insulation and lagging materials, see Table 3.

7.1.2 For insulation thickness, see Table 11.

TABLE 11 Thickness of Antisweat Insulation for Machinery and Equipment

Temperature Range, °F (°C)	Material Specification	Nominal Thickness, in. (mm) ^A	
		Unconditional Spaces	Conditioned Spaces
-20 to +40 (-29 to +4)	elastomeric foam plastic, C 534, Type II	2 (51)	1 (25) ^B
	polyimide foam, C 1482, Type I with vapor retarder	2 (51)	1 (25) ^B
41 to 125 (5 to 51)	cellular glass, C 552 Type I	3 (76)	1½ (38) ^B
	elastomeric foam plastic, C 534, Type II	¾ (19)	½ (13) ^B
	polyimide foam, C 1482, Type I with vapor retarder	1 (25)	¾ (19) ^B
	cellular glass, C 552, Type I	1 (25)	½ (13) ^B
	mineral fiber blanket, C 553, C 612	1 (25)	¾ (19) ^B

^ANominal thickness exclusive of vapor retarder.

^BThickness for application in air-conditioned spaces only.



TABLE 12 Thickness of Insulating Materials for Hot Surfaces of Machinery and Equipment, 126 to 1200°F (52 to 649°C)

Material	Maximum Temperature, °F (°C) × Thickness, in. (mm) ^A									
	150 (66)	250 (121)	350 (177)	450 (232)	550 (288)	650 (343)	750 (399)	850 (454)	950 (510)	1050 (566)
Fibrous glass felt, MIL-I-16411, Type II	1 (25)	1 (25)	1½ (38)	2½ (63)	3 (76)	4 (102)	4 (102)	5 (127)	5½ (140)	6½ (165)
Block calcium silicate, C 533	1½ (38)	1½ (38)	2 (51)	2½ (63)	4 (102)	4 (102)	4 (102)	5 (127)	5 (127)	5½ (140)
Block perlite, C 610	1½ (38)	1½ (38)	2 (51)	2½ (63)	4 (102)	4 (102)	4 (102)	5 (127)	5 (127)	5½ (140)
Refractory fiber, C 892, Grade 6	1 (25)	1 (25)	2 (51)	2½ (63)	3½ (89)	4½ (114)	4½ (114)	5½ (140)	6 (152)	7½ (191)
Refractory fiber, C 892 Grade 8	1 (25)	1 (25)	1½ (38)	2½ (63)	3 (76)	4 (102)	4 (102)	5 (127)	6 (152)	7 (178)
Mineral fiber, ^B C 553	1½ (38)	1½ (38)	2 (51)	2½ (63)	3½ (89)	3½ (89)	3½ (89)	4 (102)	4½ (114)	5 (127)
Elastomeric foam, ^C C 534, Type II	½ (13)	½ (13)								
Polyimide foam, C 1482 ^D	¾ (19)		1 (25)	1½ (38)	2 (51)					
Insulating cement, ^E C 195	2 (51)	2 (51)	2½ (63)	3½ (89)	5 (127)	5 (127)	5 (127)	5½ (140)		

^ADoes not include finishing cement.
^B1000°F (537°C) maximum temperature.
^C180°F (82°C) maximum temperature.
^DNot to be used alone above 850°F (454°C).
^ESee Supplementary Requirements S1.15.

TABLE 13 Metal Lagging Materials^A

Material	Specification	Nominal Thickness, in. (mm)
Hot-dipped galvanized steel	A 526/A 526M Coating designation G-115	0.014 (0.356)
Aluminum	B 209, 6061	0.030 (0.762)
Corrosion-resistant steel	A 167, Type 304	0.014 (0.356)

^A For use on piping and machinery insulation in locations where insulation is subject to abuse, except for uptake applications in which metal lagging shall be galvanized steel, Specification A 526/A 526M, Coating Designation G-115, not less than ½ in. (0.795 mm) thick.

7.1.3 For installation details, see Fig. 9, Fig. 10, or Fig. 11, as applicable.

7.2 *Temperature Range from 41 to 125°F (5 to 52°C)*—Use for low-temperature machinery and equipment within the temperature range.

7.2.1 For insulation and lagging materials, see Table 3.

7.2.2 For insulation thickness, see Table 11.

7.2.3 For installation details, see Fig. 9, Fig. 10, Fig. 11, or Fig. 12, as applicable.

7.2.4 *Special Conditions*—Machinery or equipment operating in this temperature range does not require insulation except where damage or discomfort may result from condensation.

7.3 *Temperature Range from 126 to 1200°F (52 to 649°C)*—Use for medium- and high-temperature machinery and equipment within the temperature range.

7.3.1 For insulation and lagging materials, see Table 3.

7.3.2 For insulation thickness, see Table 12.

7.3.3 For installation details, see Fig. 10, Fig. 11, Fig. 12, Fig. 13, or Fig. 14, as applicable.

8. Insulation and Lagging Requirements for Removable Covers for Valves, Fittings, Flanges, and Machinery or Equipment

8.1 *Removable Covers*—Flanged valves and fittings and pipeline flanges shall have removable covers to permit servicing of takedown joints.

8.1.1 Removable covers shall be manufactured using materials specified in 8.2-8.4 and to thicknesses specified in Tables 4-7. Stitching, lacing, and quilting (required to prevent sagging) shall be accomplished with materials specified in 8.5 and as shown in Figs. 15-17.

8.1.2 Removable covers may also be manufactured from segments of block insulation or from preformed sectional pipe covering and molded (preformed) components. When a removable cover is made of segments of block insulation or preformed (preformed) sectional pipe covering, it shall be of the same material and thickness as the adjoining pipe insulation.

8.2 Filler Materials for Removable Blankets:

8.2.1 Fibrous glass felt, conforming with MIL-I-16411, Type II.

8.2.2 Refractory fiber blanket, in accordance with Specification C 892, Grade 8.

8.2.3 Refractory fiber blanket, also in accordance with Specification C 892, Grade 6.

8.2.4 Mineral fiber blanket, in accordance with Specification C 612, Class 4.

8.3 Covering or Encapsulating Materials for Removable Blankets:

8.3.1 For surface temperatures 450°F (232°C) and below, the filler shall be encapsulated with fiberglass cloth, conforming with MIL-C-20079, Type I, Class 9 (see Fig. 18, Detail A).

8.3.2 For surface temperatures above 450°F (232°C), the entire outside surface shall be encapsulated with TY304 stainless steel wire mesh, 0.011-in. (0.25 mm) diameter, No. 60 density, and crimped (see Fig. 18, Detail B). Alternatively, the entire outside surface may be encapsulated with fiberglass cloth, inserted with stainless steel reinforcement, in accordance with HH-P-31, Type I, Class 1.

8.3.3 The cold or top side of the surface shall be covered with fiberglass cloth, conforming with MIL-C-20079, Type I, Class 9. The bottom and side surface areas shall be covered as follows:

8.3.3.1 Fiberglass cloth, shall be inserted with stainless steel wire reinforcement, conforming with HH-P-31, Type I, Class 1 (see Fig. 18, Detail C); or

8.3.3.2 Fiberglass cloth, conforming with MIL-C-20079, Type I, Class 9, with TY304 stainless steel wire mesh, 0.008-in. (0.21-mm) diameter and No. 60 density, shall be crimped sewn onto the fibrous cloth (see Fig. 18, Detail D); or

8.3.3.3 TY304 stainless steel wire mesh, 0.011-in. (0.25-mm) diameter and No. 60 density, shall be crimped (see Fig. 18, Detail E).



TABLE 14 Thickness of Fiberglass Felt for Removable Insulation Blankets^A

Nominal Pipe Size, in. (mm)	Maximum Temperature, °F (°C) × Thickness, in. (mm)									
	150 (66)	250 (121)	350 (177)	450 (232)	550 (288)	650 (343)	750 (399)	850 (454)	950 (510)	1050 (566)
½ (13)	1 (25)	1 (25)	1½ (38)	1½ (38)	2 (51)	2 (51)	2½ (63)	2½ (63)	3 (76)	3½ (89)
1 (25)	1 (25)	1 (25)	1 (25)	1½ (38)	2 (51)	2 (51)	2½ (63)	3 (76)	3 (76)	3½ (89)
1½ (38)	1 (25)	1 (25)	1 (25)	1½ (38)	2 (51)	2½ (63)	2½ (63)	3 (76)	3½ (89)	4 (102)
2 (51)	1 (25)	1 (25)	1 (25)	1½ (38)	2 (51)	2½ (63)	2½ (63)	3 (76)	3½ (89)	4 (102)
3 (76)	1 (25)	1 (25)	1 (25)	1½ (38)	2 (51)	2½ (63)	3 (76)	3½ (89)	4 (102)	4½ (114)
4 (102)	1 (25)	1 (25)	1½ (38)	2 (51)	2½ (63)	3 (76)	3 (76)	3½ (89)	4 (102)	5 (127)
6 (152)	1 (25)	1 (25)	1½ (38)	2 (51)	2½ (63)	3 (76)	3 (76)	4 (102)	4½ (114)	5½ (140)
8 (203)	1 (25)	1 (25)	1½ (38)	2 (51)	2½ (63)	3 (76)	3½ (89)	4 (102)	5 (127)	5½ (140)
10 (254)	1 (25)	1 (25)	1½ (38)	2 (51)	2½ (63)	3½ (89)	3½ (89)	4 (102)	5 (127)	6 (152)
12 (305)	1 (25)	1 (25)	1½ (38)	2 (51)	2½ (63)	3½ (89)	3½ (89)	4½ (114)	5 (127)	6 (152)
14 (356)	1 (25)	1 (25)	1½ (38)	2 (51)	2½ (63)	3½ (89)	3½ (89)	4½ (114)	5½ (140)	6 (152)
16 (406)	1 (25)	1 (25)	1½ (38)	2 (51)	3 (76)	3½ (89)	3½ (89)	4½ (114)	5½ (140)	6½ (165)
18 (457)	1 (25)	1 (25)	1½ (38)	2 (51)	3 (76)	3½ (89)	4 (102)	4½ (114)	5½ (140)	6½ (165)

^AThickness of fiberglass felt, in accordance with MIL-I-16411, Type II.

TABLE 15 Thickness of 8-lb/ft³ (128-kg/m³) Refractory Fiber Blanket for Removable Insulation Blankets^A

Nominal Pipe Size, in. (mm)	Maximum Temperature, °F (°C) × Thickness, in. (mm)									
	150 (66)	250 (121)	350 (177)	450 (232)	550 (288)	650 (343)	750 (399)	850 (454)	950 (510)	1050 (566)
½ (13)	1 (25)	1 (25)	1 (25)	1½ (38)	1½ (38)	2 (51)	2 (51)	2½ (63)	3 (76)	3 (76)
1 (25)	1 (25)	1 (25)	1 (25)	1½ (38)	2 (51)	2 (51)	2½ (63)	3 (76)	3 (76)	3½ (89)
1½ (38)	1 (25)	1 (25)	1 (25)	1½ (38)	2 (51)	2½ (63)	2½ (63)	3 (76)	3½ (89)	4 (102)
2 (51)	1 (25)	1 (25)	1 (25)	1½ (38)	2 (51)	2½ (63)	2½ (63)	3 (76)	3½ (89)	4 (102)
3 (76)	1 (25)	1 (25)	1½ (38)	2 (51)	2½ (63)	3 (76)	3 (76)	3½ (89)	4 (102)	4½ (114)
4 (102)	1 (25)	1 (25)	1½ (38)	2 (50)	2½ (63)	3 (76)	3 (76)	3½ (89)	4 (102)	4½ (114)
6 (152)	1 (25)	1 (25)	1½ (38)	2 (51)	2½ (63)	3 (76)	3 (76)	4 (102)	4½ (114)	5 (127)
8 (203)	1 (25)	1 (25)	1½ (38)	2 (51)	2½ (63)	3½ (89)	3½ (89)	4 (102)	4½ (114)	5½ (140)
10 (254)	1 (25)	1 (25)	1½ (38)	2 (51)	3 (76)	3½ (89)	3½ (89)	4 (102)	5 (127)	5½ (140)
12 (305)	1 (25)	1 (25)	1½ (38)	2 (51)	3 (76)	3½ (89)	3½ (89)	4½ (114)	5 (127)	6 (152)
14 (356)	1 (25)	1 (25)	1½ (38)	2 (51)	3 (76)	3½ (89)	3½ (89)	4½ (114)	5 (127)	6 (152)
16 (406)	1 (25)	1 (25)	1½ (38)	2 (51)	3 (76)	3½ (89)	3½ (89)	4½ (114)	5 (127)	6 (152)
18 (457)	1 (25)	1 (25)	1½ (38)	2½ (63)	3 (76)	3½ (89)	4 (102)	4½ (114)	5½ (140)	6 (152)

^AThickness of 8-lb/ft³ (128-kg/m³) refractory fiber blanket in accordance with Specification C 892, Grade 8.

TABLE 16 Thickness of 6-lb/ft³ (96-kg/m³) Refractory Fiber Blanket for Removable Insulation Blankets^A

Nominal Pipe Size, in. (mm)	Maximum Temperature, °F (°C) × Thickness, in. (mm)									
	150 (66)	250 (121)	350 (177)	450 (232)	550 (288)	650 (343)	750 (399)	850 (454)	950 (510)	1050 (566)
½ (13)	1 (25)	1 (25)	1 (25)	1½ (38)	1½ (38)	2 (51)	2 (51)	2½ (63)	2½ (63)	3 (76)
1 (25)	1 (25)	1 (25)	1 (25)	1½ (38)	2 (51)	2½ (63)	2½ (63)	2½ (63)	3 (76)	3½ (89)
1½ (38)	1 (25)	1 (25)	1½ (38)	1½ (38)	2 (51)	2½ (63)	2½ (63)	2½ (63)	3 (76)	4 (102)
2 (51)	1 (25)	1 (25)	1½ (38)	1½ (38)	2 (51)	2½ (63)	2½ (63)	3 (76)	3½ (89)	4 (102)
3 (76)	1 (25)	1 (25)	1½ (38)	2 (51)	2½ (63)	3 (76)	3 (76)	3½ (89)	4 (102)	4½ (114)
4 (102)	1 (25)	1 (25)	1½ (38)	2 (51)	2½ (63)	3 (76)	3 (76)	3½ (89)	4½ (114)	5 (127)
6 (152)	1 (25)	1 (25)	1½ (38)	2 (51)	2½ (63)	3½ (89)	3½ (89)	4 (102)	4½ (114)	5½ (140)
8 (203)	1 (25)	1 (25)	1½ (38)	2 (51)	2½ (63)	3½ (89)	3½ (89)	4 (102)	5 (127)	5½ (140)
10 (254)	1 (25)	1 (25)	1½ (38)	2 (51)	3 (76)	3½ (89)	3½ (89)	4½ (114)	5 (127)	6 (152)
12 (305)	1 (25)	1 (25)	1½ (38)	2½ (63)	3 (76)	3½ (89)	4 (102)	4½ (114)	5½ (140)	6 (152)
14 (356)	1 (25)	1 (25)	2 (51)	2½ (63)	3 (76)	3½ (89)	4 (102)	4½ (114)	5½ (140)	6½ (165)
16 (406)	1 (25)	1 (25)	2 (51)	2½ (63)	3 (76)	3½ (89)	4 (102)	4½ (114)	5½ (140)	6½ (165)
18 (457)	1 (25)	1 (25)	2 (51)	2½ (63)	3½ (89)	3½ (89)	4 (102)	5 (127)	6 (152)	6½ (165)

^AThickness of 6-lb/ft³ (96-kg/m³) refractory fiber blanket in accordance with Specification C 892, Grade 6.

8.4 *Alternative Covering Materials* (for surface temperatures 450°F (232°C) and below, and for cold or top-side covering for temperatures above 450°F), are provided for removable blankets to be used in areas exposed to weather or where liquid penetration could present a fire hazard. Alternative coverings are as follows:

- 8.4.1 Silicone-impregnated fiberglass cloth,
- 8.4.2 Silicone-impregnated fiberglass cloth with aluminized facing on one side, and
- 8.4.3 Fiberglass cloth with aluminum or stainless steel facing laminated to one side.

8.5 *Hardware and Accessory Items for Removable Blanket Construction*—Necessary items shall include blanket lacing

devices, blanket quilting devices, stitching materials, and installation materials.

8.5.1 *Blanket Lacing Devices:*

8.5.1.1 TY304 stainless steel lacing rings with lacing washers (see Fig. 19).

8.5.1.2 TY304 stainless steel lacing hooks with lacing washers (see Fig. 20).

8.5.1.3 TY303 stainless steel lacing capstan assembly sets (see Fig. 21).

8.5.1.4 TY304 stainless steel mechanical hook sets (see Fig. 22).

8.5.2 *Blanket Quilting Devices:*



TABLE 17 Thickness of Fiberglass Blanket for Removable Insulation Blankets^A

Nominal Pipe Size, in. (mm)	Maximum Temperature, °F (°C) × Thickness, in. (mm)							
	150 (66)	250 (121)	350 (177)	450 (232)	550 (288)	650 (343)	750 (399)	850 (454)
½ (13)	½ (13)	½ (13)	1 (25)	1 (25)	1½ (38)	2 (51)	2½ (63)	3 (76)
1 (25)	½ (13)	½ (13)	1 (25)	1½ (38)	2 (51)	2 (51)	2½ (63)	3 (76)
1½ (38)	½ (13)	½ (13)	1 (25)	1½ (38)	2 (51)	2 (51)	3 (76)	3½ (89)
2 (51)	½ (13)	½ (13)	1 (25)	1½ (38)	2 (51)	2 (51)	3 (76)	4 (102)
3 (76)	½ (13)	½ (13)	1 (25)	1½ (38)	2 (51)	2 (51)	3 (76)	4 (102)
4 (102)	½ (13)	½ (13)	1 (25)	1½ (38)	2½ (63)	2½ (63)	3½ (89)	4½ (114)
6 (152)	½ (13)	½ (13)	1 (25)	2 (51)	2½ (63)	2½ (63)	3½ (89)	5 (127)
8 (203)	½ (13)	½ (13)	1 (25)	2 (51)	2½ (63)	2½ (63)	4 (102)	5 (127)
10 (254)	½ (13)	½ (13)	1½ (38)	2 (51)	2½ (63)	2½ (63)	4 (102)	5½ (140)
12 (305)	½ (13)	1 (25)	1½ (38)	2 (51)	2½ (63)	2½ (63)	4 (102)	5½ (140)
14 (356)	½ (13)	1 (25)	1½ (38)	2 (51)	3 (76)	4 (102)	4 (102)	5½ (140)
16 (406)	½ (13)	1 (25)	1½ (38)	2 (51)	3 (76)	4 (102)	4½ (114)	5½ (140)
18 (457)	½ (13)	1 (25)	1½ (38)	2 (51)	3 (76)	4 (102)	4½ (114)	6 (152)

^AThickness of fiberglass blanket, in accordance with Specification C 612, Type II, C 553, Type IV.

8.5.2.1 TY304 stainless steel mechanical quilt sets (see Fig. 23).

8.5.2.2 TY304 stainless steel lacing washers with lacing wire (see Fig. 23).

8.5.3 Stitching Materials:

8.5.3.1 TY304 stainless steel hog rings.

8.5.3.2 TY304 stainless steel thread (0.011-in. (0.25-mm) diameter).

8.5.3.3 TY304 stainless steel staples.

8.5.3.4 Fiberglass thread (plain, polytetrafluoroethylene coated and wire inserted with monel or TY304 stainless steel, or both).

8.5.4 Installation Materials:

8.5.4.1 No. 18 gage copper lacing wire.

8.5.4.2 No. 18 gage soft or annealed TY304 stainless steel lacing wire.

8.5.4.3 No. 18 gage galvanized iron lacing wire.

8.5.4.4 TY304 stainless steel hog rings (particularly for installing thermal tape, refer also to Section 9).

8.6 Special Conditions:

8.6.1 Reuseable covers for machinery and equipment shall be fabricated from materials specified in Tables 14-17, in accordance with methods shown in Fig. 18 and configured to suit the specific application.

8.6.2 Unfired pressure vessels with butt welded inserts for which periodic radiographic inspection of the joint is required should have removable reuseable covers installed over the insert. These covers should extend 4 in. (100 mm) beyond the weld joint.

8.6.3 Removable covers shall not be used on systems

insulated with elastomeric-foamed plastic insulation.

8.6.4 Services subject to frequent maintenance, such as reducing and regulating valves, shall be provided with easily removed and replaced tailored pads.

8.6.5 Removable blankets should not be used on cold systems (below ambient) or on systems where a vapor barrier is required.

8.6.6 When stitching two or more covering or encapsulating materials together, stainless steel staples, hog rings, 0.011-in. (0.25-mm) diameter stitching wire, or fiberglass thread (plain or wire inserted) may be used.

8.6.7 All construction details apply to removable blankets for flanges, valves, machinery and equipment, and other miscellaneous areas as determined by the specifier.

8.6.8 When installing removable blankets on valves, flanges, and various pieces of equipment, note that all void areas behind the insulation blanket are to be filled. The total required thickness of insulation shall not be achieved by including a loose wrap of fibrous glass felt or refractory fiber blanket as part of the required thickness.

9. Requirements for Thermal Insulating Tape

9.1 *Thermal Insulating Tape*—May be applied to pipe, sizes ¼ in. (8 mm) to ¾ in. (20 mm), for temperatures between 125 and 150°F (52 and 66°C) using materials specified in Section 8 and to thicknesses specified in Table 14. For manufacturing and installation details, see Fig. 6.

9.2 *Filler Materials for Thermal Insulating Tape*—See 8.2.

9.3 *Covering or Encapsulating Materials for Thermal Insulating Tape:*

9.3.1 For surface temperatures below 220°F (105°C), the entire outside surface shall be encapsulated with fiberglass cloth, conforming with MIL-C-20079, Type I, Class 3.

9.3.2 For surface temperatures 220 to 450°F (105 to 232°C), the entire outside surface shall be encapsulated with fiberglass cloth, conforming with MIL-C-20079, Type I, Class 9.

9.3.3 For surface temperatures above 450°F (232°C), the entire outside surface shall be encapsulated with fiberglass cloth, conforming with MIL-C-20079, Type I, Class 9, with an inner jacket of TY304 stainless steel wire mesh, 0.008-in. (0.21-mm) diameter, No. 60 density and crimped. Alternatively, the entire outside surface may be encapsulated with fiberglass cloth, inserted with stainless steel wire reinforcement, in accordance with HH-P-31, Type I, Class 1.

9.4 *Hardware and Accessory Items for Thermal Insulating Construction*—See 8.5.

9.5 *Special Conditions*—See 8.6.

10. Keywords

10.1 insulation; lagging; machinery insulation; marine; piping insulation; ship; shipboard insulation; thermal insulation; vessel

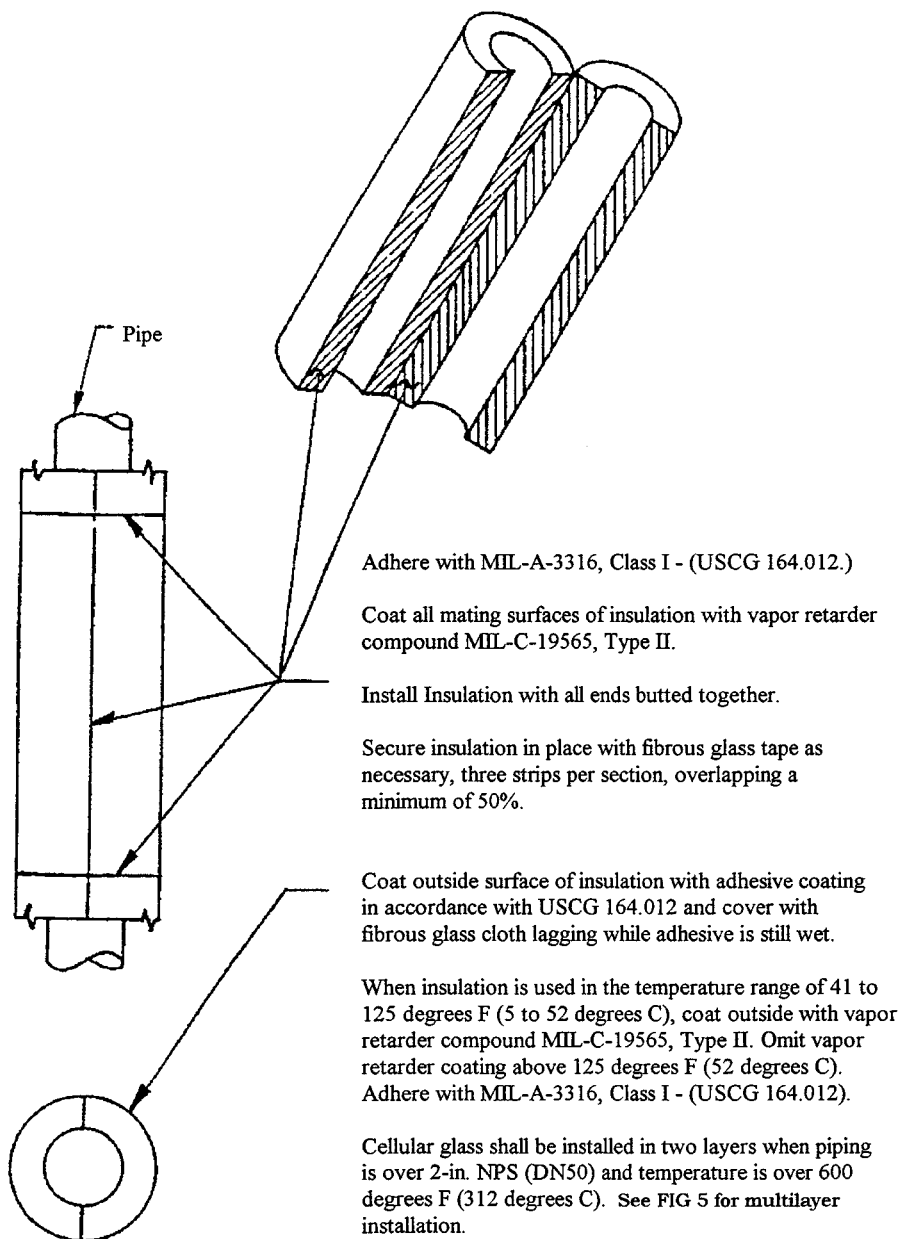
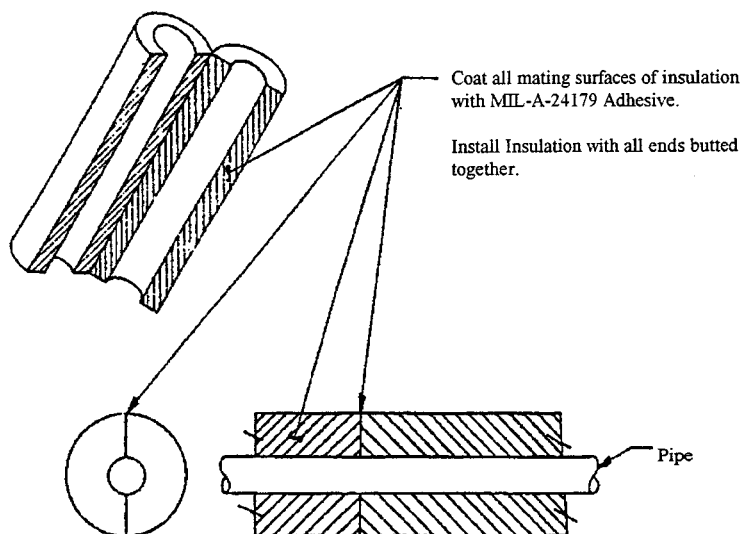
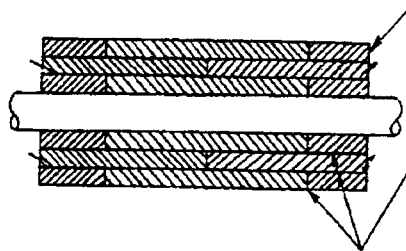

FIG. 1 Installation of Cellular Glass Pipe Insulation (Specification C 552)



Elastomeric Foamed Plastic Insulation MIL-P-15280 or EB 4013, may be applied in 1/4 in. (6mm) minimum thickness layers as necessary to build up the required thickness.



All end and horizontal joints shall be butted together and all joints staggered for multiple layer installation and secured with MIL-A-24179 Adhesive.

Application of a vapor retarder is not required on Elastomeric Foamed Plastic Insulation

Elastomeric Foamed Plastic Insulation should be coated with Adhesive MIL-A-3316, Class I, and covered with a glass cloth lagging per MIL-C-20079 or covered with re-wettable glass cloth per MIL-C-20079, only in areas where it is subject to damage.

FIG. 2 Installation of Elastomeric-Foamed Plastic Insulation (MIL-P-15280 or EB 4013)

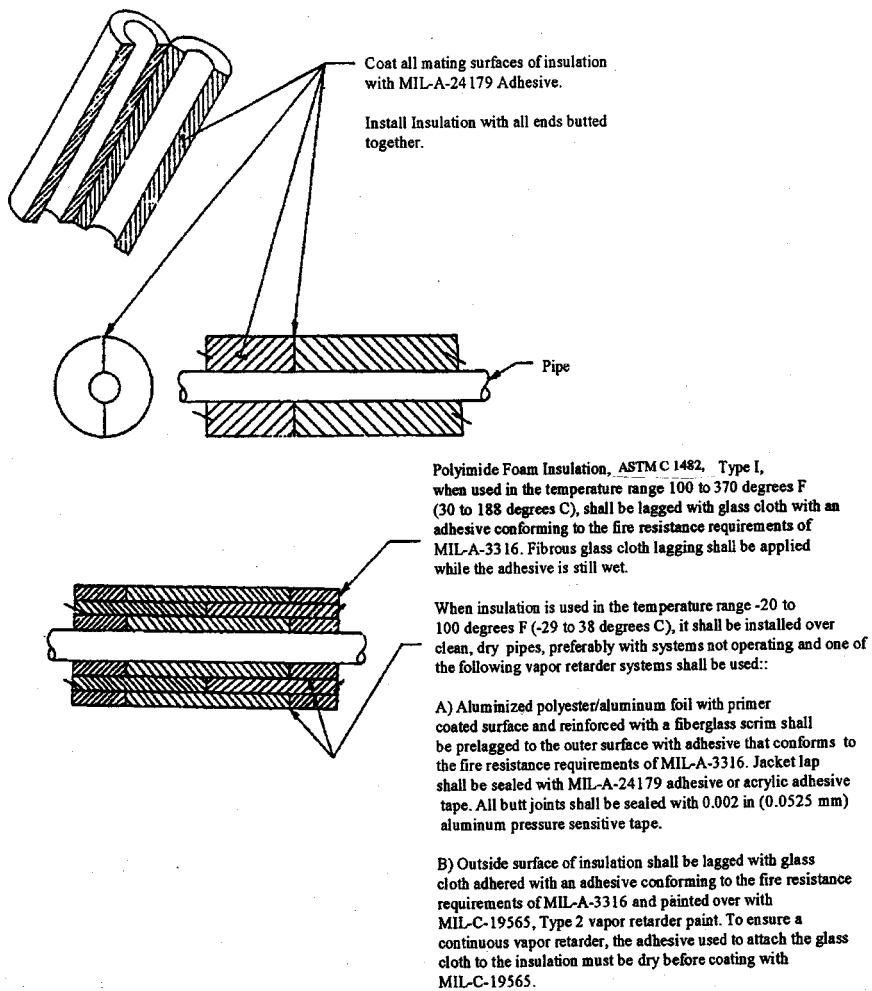

FIG. 3 Installation of Polyimide Foam Insulation (Specification C 1482)

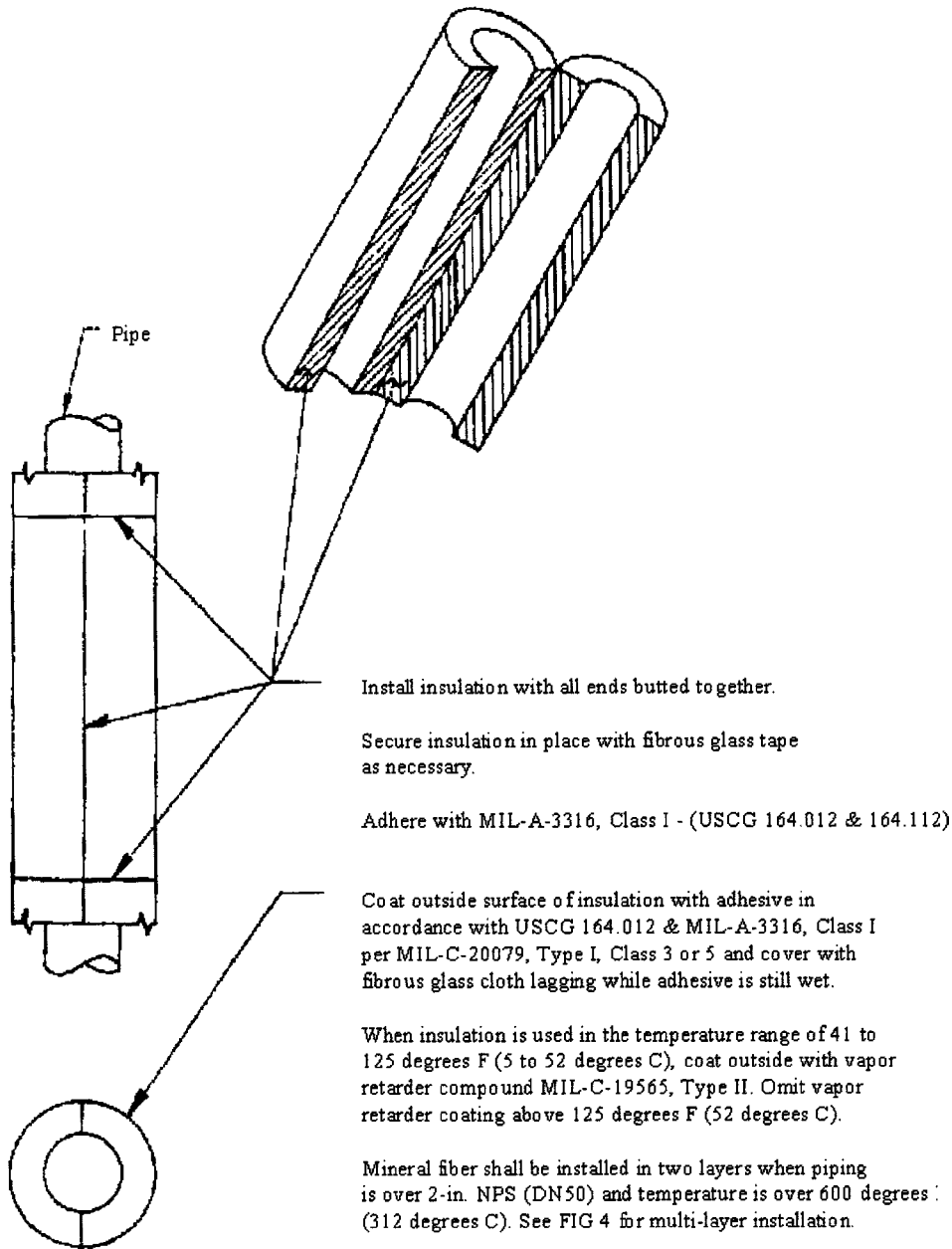
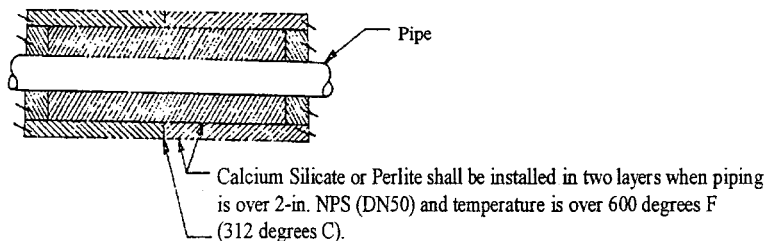

FIG. 4 Installation of Mineral Fiber Pipe Insulation (Specification C 547)



All end and horizontal joints shall be butted together and all joints staggered for multi-layer installations.

NOTE 1—For piping over 600°F (312°C), either single- or double-layer suitable expansion joints to permit thermal movement of the pipe without opening of the insulation should be provided.

FIG. 5 Installation of Calcium Silicate Pipe Insulation (Specification C 533) and Perlite Pipe Insulation (Specification C 610)

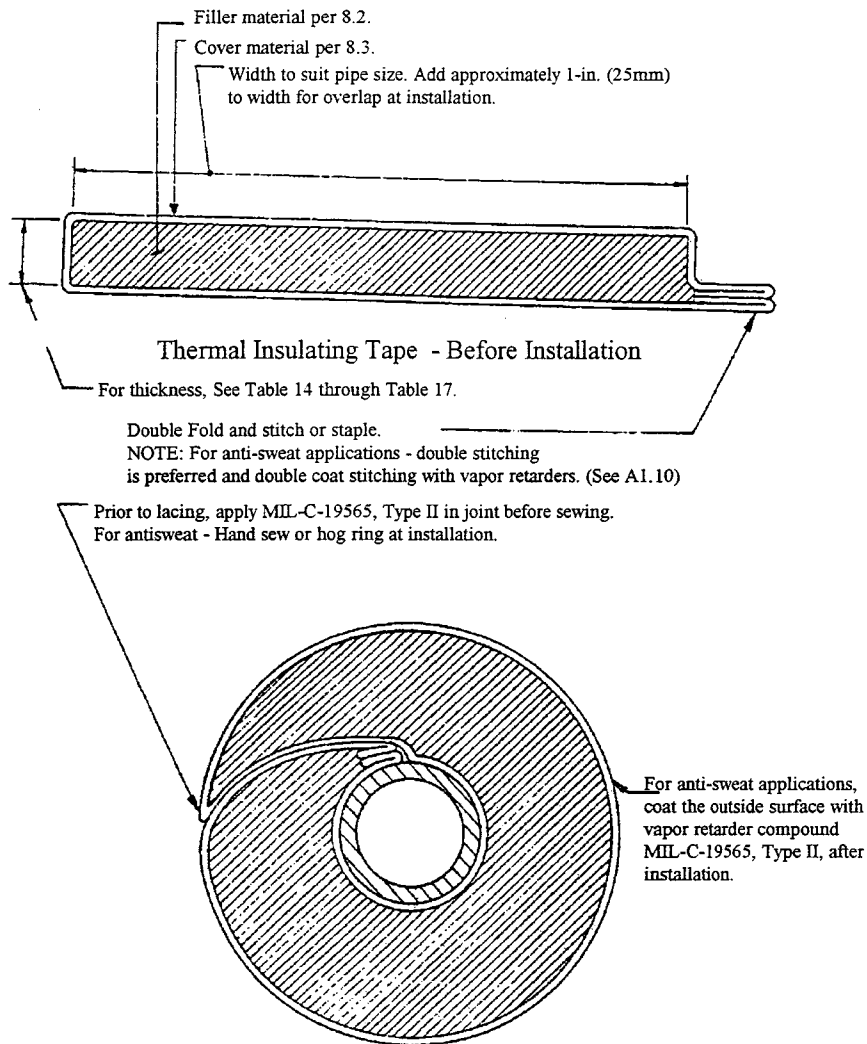

Thermal Insulating Tape After Installation
FIG. 6 Installation of Thermal Insulating Tape

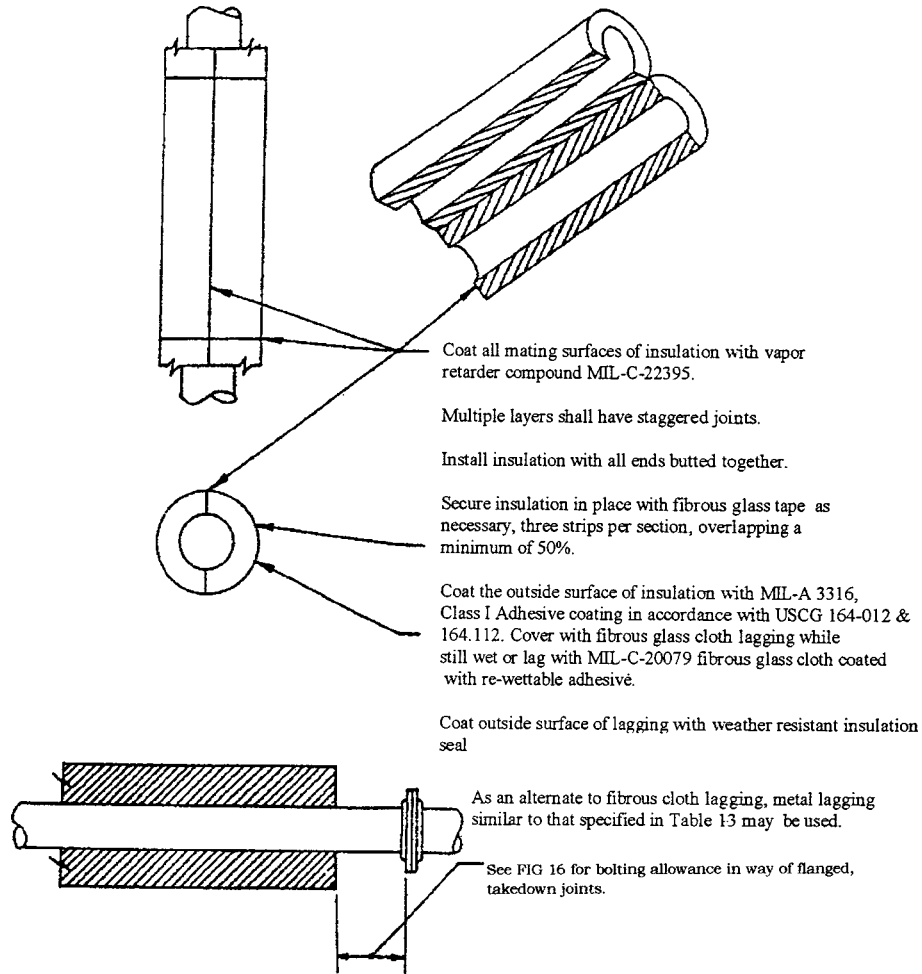

FIG. 7 Installation of Cellular Glass Pipe Insulation (Specification C 552) in the Weather

ASTM F 683

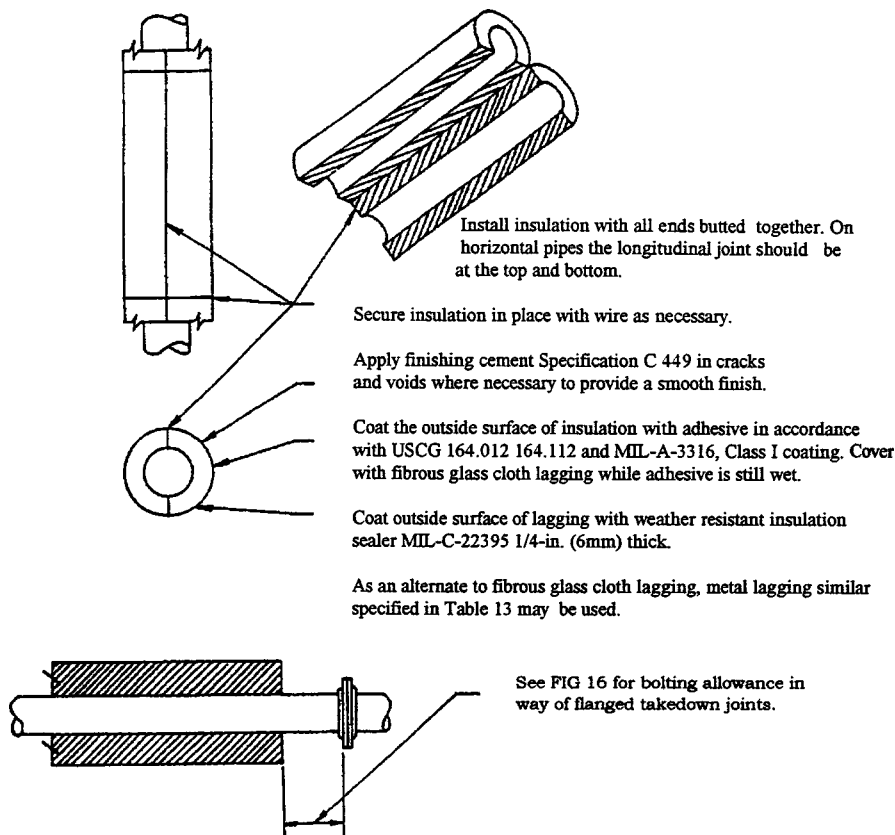

FIG. 8 Installation of Mineral Fiber Pipe Insulation (Specification C 547) or Calcium Silicate Pipe Insulation (Specification C 533) or Perlite Pipe Insulation (Specification C 610) in the Weather

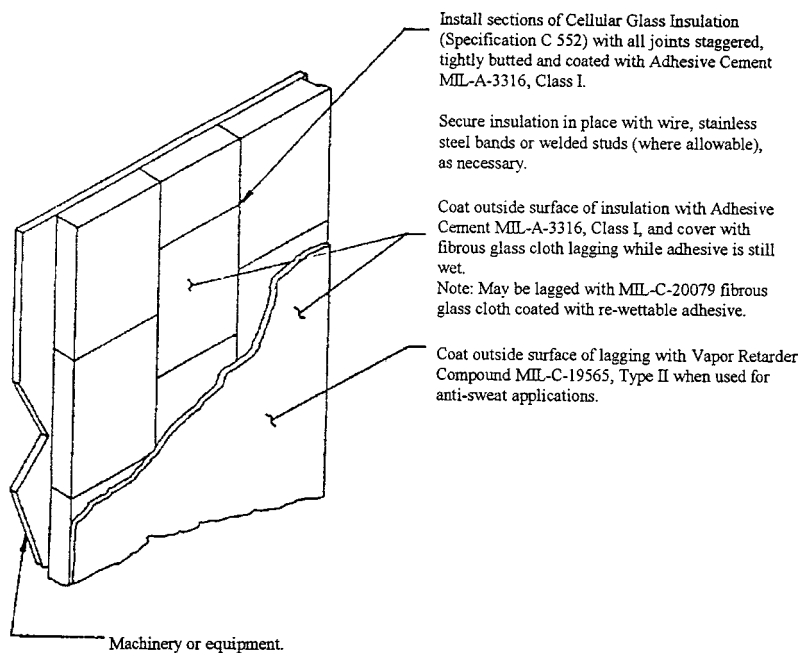

FIG. 9 Installation of Cellular (Foamed) Glass Insulation (Specification C 552) on Machinery and Equipment

ASTM F 683

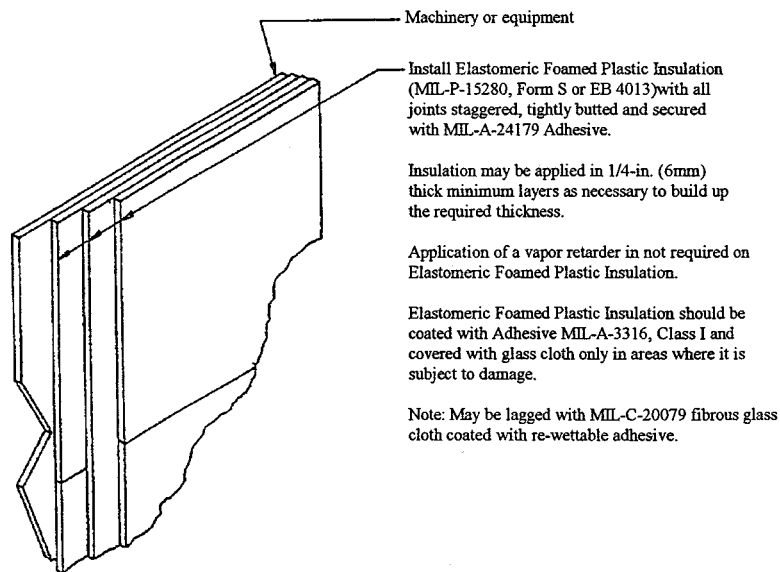

FIG. 10 Installation of Elastomeric Foamed Plastic Insulation (MIL-P-15280 or EB 4013) on Machinery or Equipment

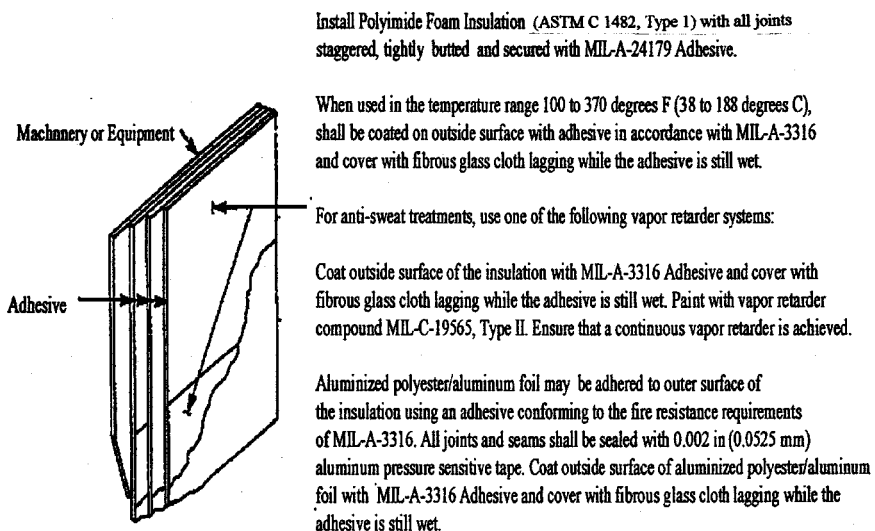

FIG. 11 Installation of Polyimide Foam Insulation (Specification C 1482, Type I) on Machinery and Equipment

ASTM F 683

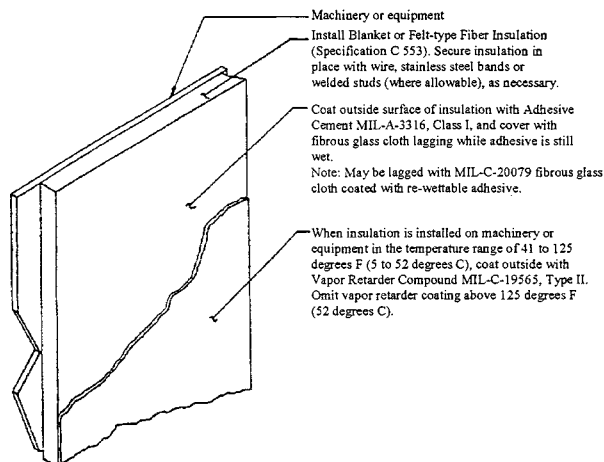

FIG. 12 Installation of Mineral Fiber Blanket or Felt Insulation (Specification C 553) on Machinery or Equipment (400°F Max) (204°C)

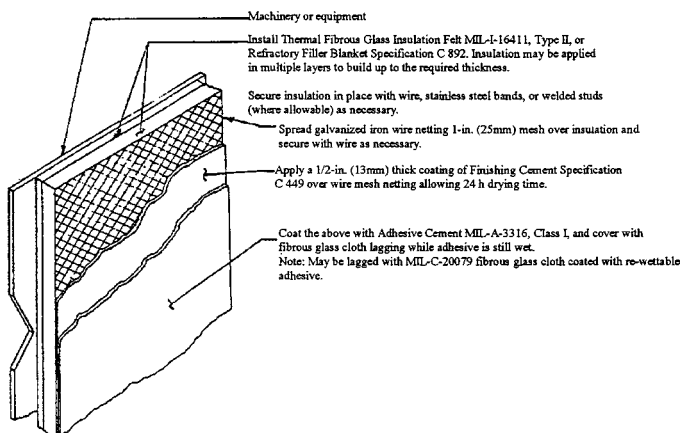

FIG. 13 Installation of Thermal Fibrous Glass Felt Insulation (MIL-I-16411) or Refractory Fiber Blanket Insulation (Specification C 892) on Machinery and Equipment (126 to 1200°F) (52 to 649°C)

ASTM F 683

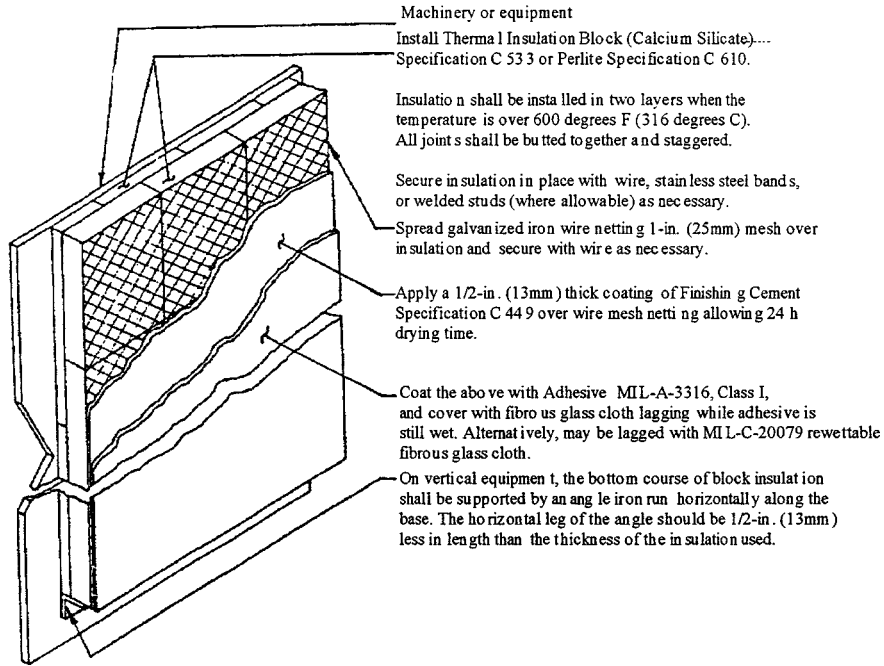

FIG. 14 Installation of Thermal Insulation Block (Calcium Silicate) (Specification C 533) or Perlite (Specification C 610) on Machinery and Equipment

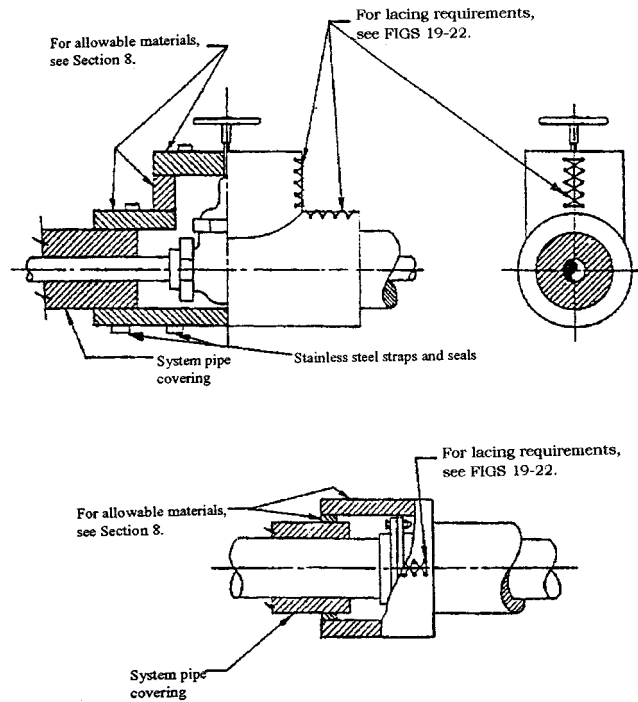

FIG. 15 Installation of Removable Covers for Valves, Fittings, and Flanges

ASTM F 683

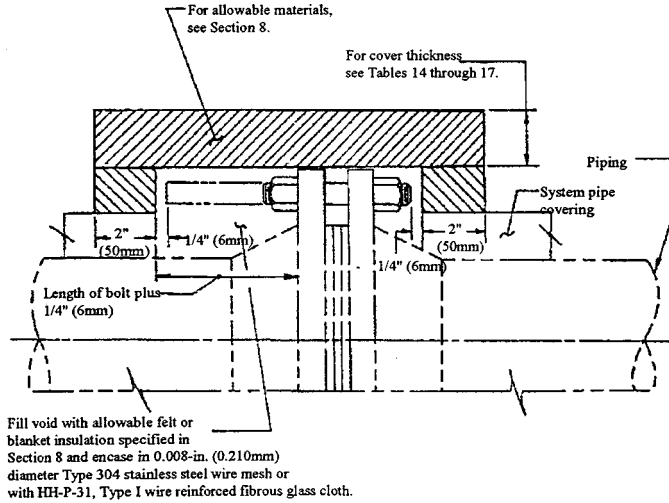

FIG. 16 Typical Removable Flange Cover in Which Flange Diameter is Larger Than the Outside Diameter of the Adjacent Pipe Covering

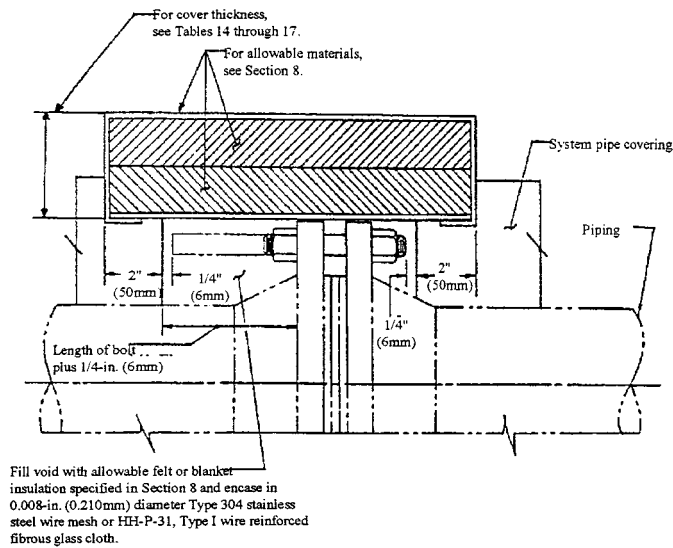
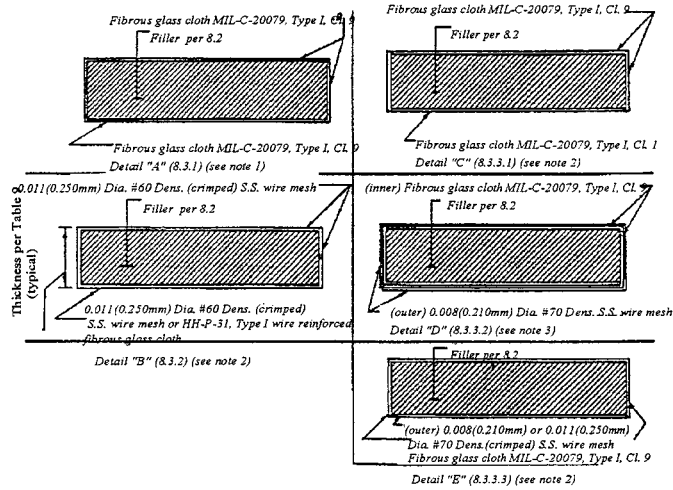

FIG. 17 Typical Removable Flange Cover in Which Flange Diameter is Smaller Than the Outside Diameter of the Adjacent Pipe Covering

ASTM F 683



NOTE 1—For surface temperatures 450°F (232°C) and below.

NOTE 2—For surface temperatures above 450°F (232°C).

FIG. 18 Covering or Encapsulating Materials for Removable Blankets

ASTM F 683

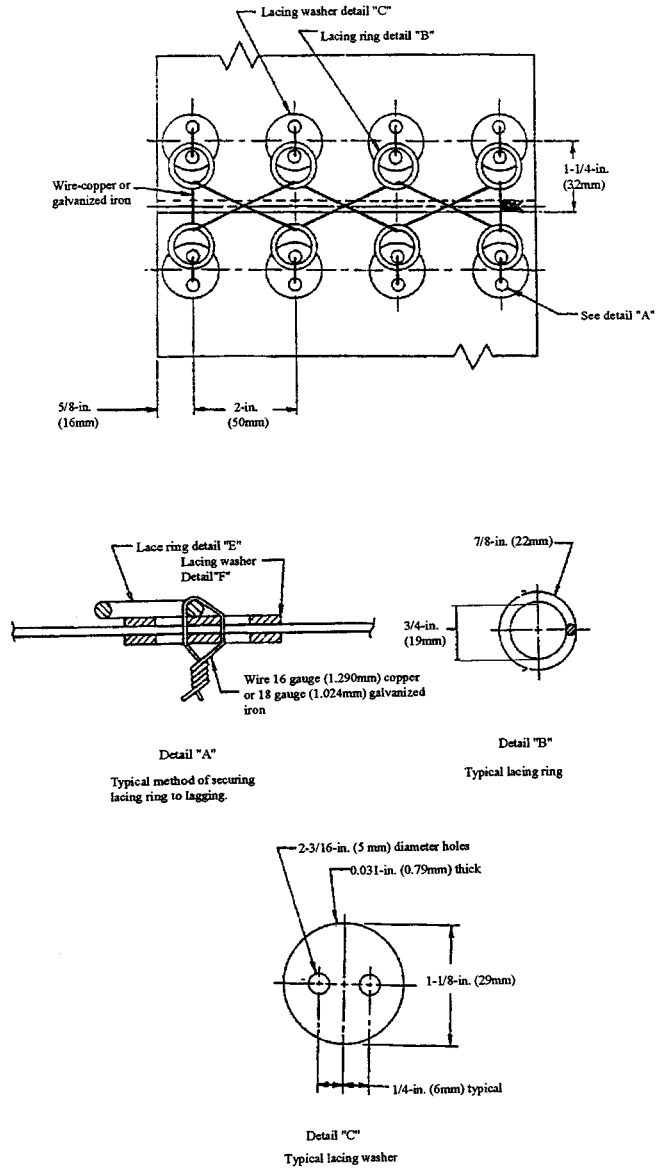

FIG. 19 Typical Method of Lacing Removable Covers Using Lacing Rings

ASTM F 683

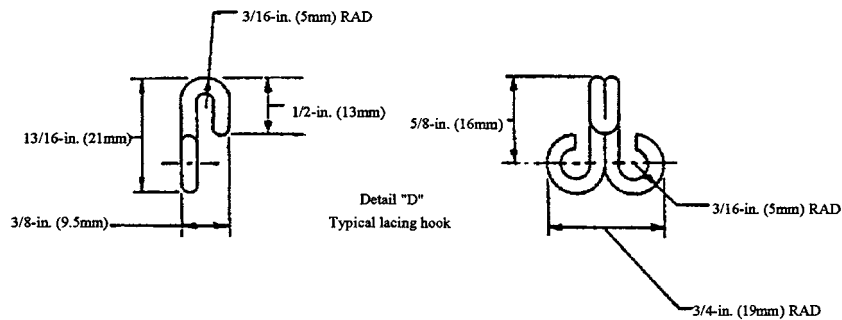
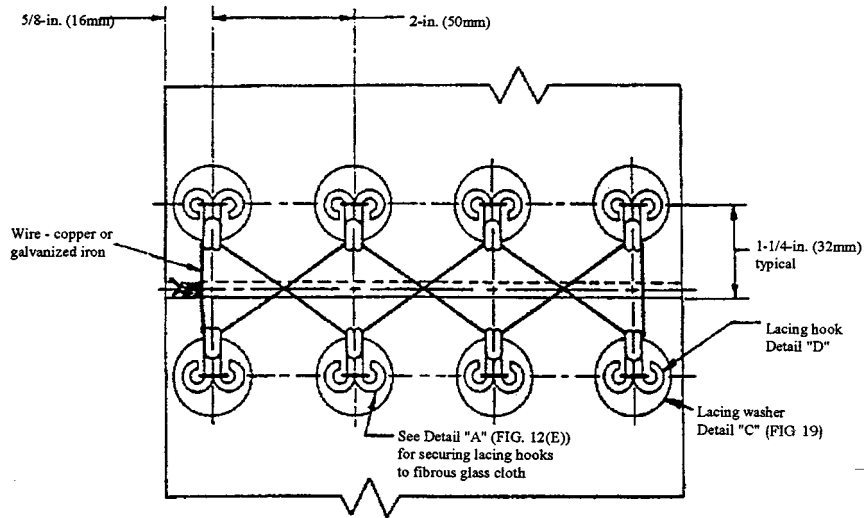

FIG. 20 Typical Method of Lacing Removable Covers Using Lacing Hooks

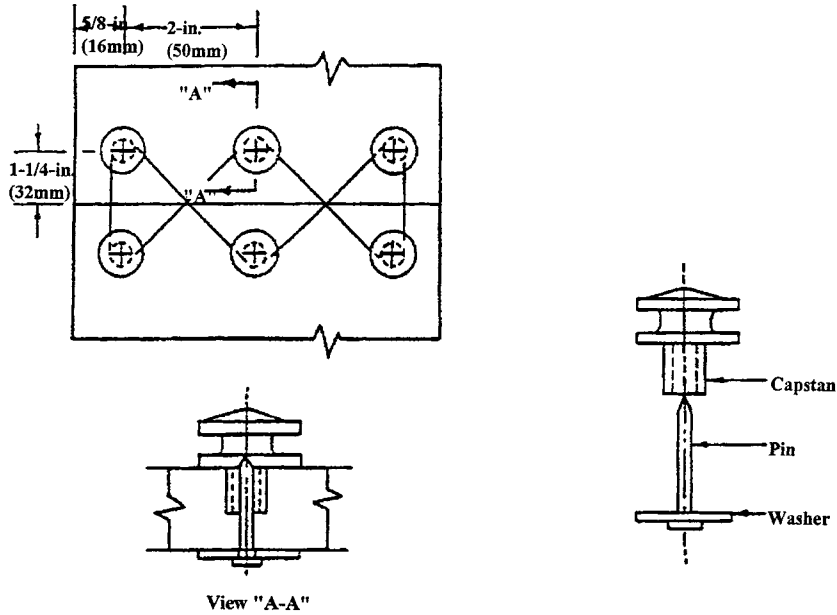

FIG. 21 Alternate Method of Lacing Removable Covers Using Lacing Capstan Assembly Sets

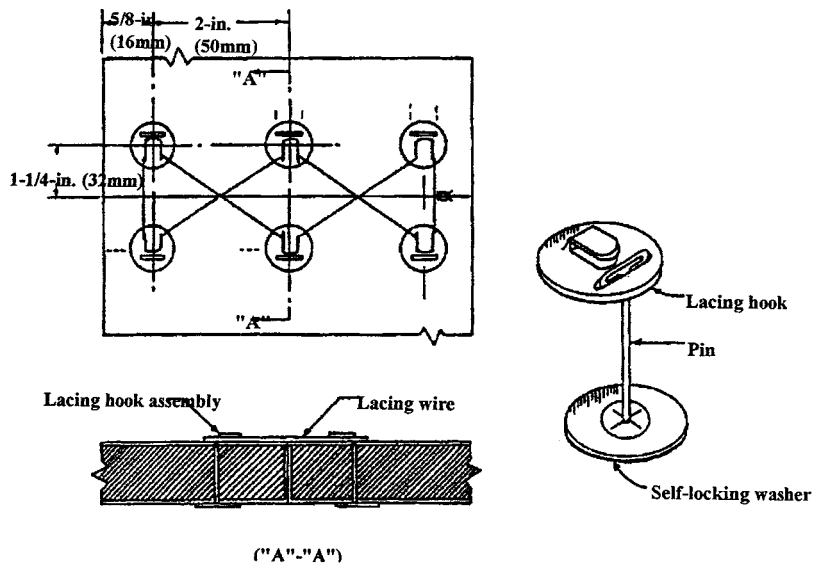

FIG. 22 Alternate Method of Lacing Removable Covers Using Mechanical Hook Sets

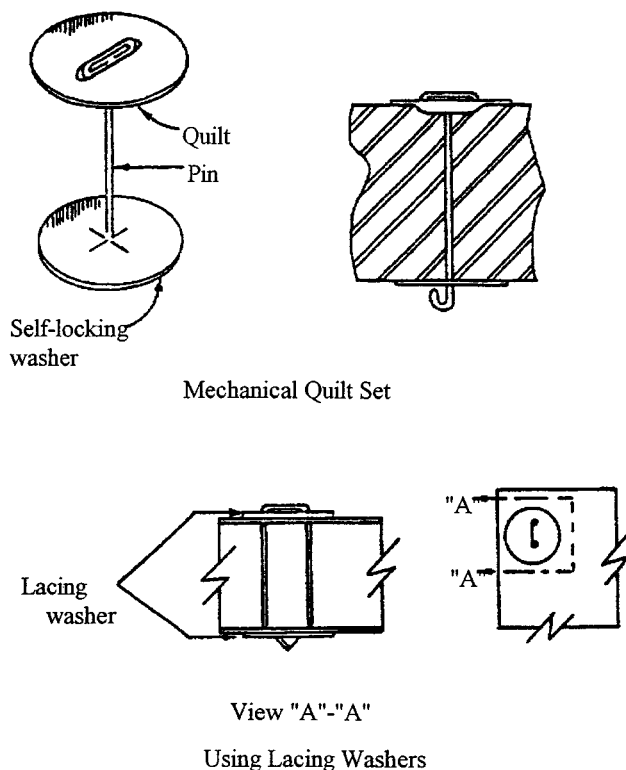

FIG. 23 Typical Methods of Quilting Removable Covers

SUPPLEMENTARY REQUIREMENTS

S1. Supplemental Requirements and Exceptions to the Requirements of Practice F 683 for Ships of the U.S. Navy

S1.1 The U.S. Navy vessel insulation shall be installed in accordance with details in NAVSHIPS Drawings 804-5959214, 804-5959212, and Naval Ships Technical Manual, Chapter 635. Insulation details in this practice are for guidance only.

S1.1.1 Materials and their thicknesses approved for insulation and lagging for specific applications and temperature ranges are specified in Tables S1.1 and S1.2.

S1.2 Ceramic fiber insulation (Specification C 892) shall not be installed aboard vessel in accordance with COMNAVSEASYSKOM message R 131446Z NOV 86 ZYB, unless there presently are no NAVSEA-approved substitutes for a specific application. Where previously installed ceramic (refractory) fiber insulation or lagging materials containing ceramic (refractory) fibers are removed, restoration shall be with materials free of ceramic (refractory) fibers unless there are no NAVSEA-approved substitutes identified for a specific application.

S1.3 Cellular glass block and pipe thermal insulation (Specification C 552) shall not be used.

S1.4 Mineral fiber blanket and felt insulation (Specification C 553) shall not be used. For U.S. Navy applications, use MIL-I-2818 in accordance with Table S1.3. For passive fire

protection applications, refer to NAVSEA Drawing No. 803-5184182.

S1.5 Mineral fiber preformed pipe insulation (Specification C 547) shall not be used. Insulate in accordance with Table S1.4.

S1.6 Fibrous glass pipe insulation shall be as specified in MIL-I-22344 and shall be used only on piping no greater than 1-in. NPS (25 mm) with maximum temperature limit of 370°F (188°C) in place of Specification C 547, Class 2. See Table S1.4 for restrictions on this material's use.

S1.7 Calcium silicate block and thermal insulation shall be as specified in MIL-I-2819 and MIL-I-2781, respectively, in place of Specification C 533. Insulate in accordance with Tables S1.3 and S1.5.

S1.8 Mineral fiber block and board thermal insulation (Specification C 612) shall not be used.

S1.9 The requirements of 5.4, 5.7, and 5.10 do not apply to U.S. Navy vessels.

S1.10 Thermal insulating tape in accordance with Fig. 5 shall be used only on a temporary basis, such as repair of insulation while the vessel is at sea. Apply in accordance with Table S1.6.

S1.11 Cloth and tape lagging shall be painted after installation with one coat of nonflaming paint conforming to formula No. 124 of DoD-E-24607 or water base DoD-C-24596 or Navy formula 25A, if necessary for appearance. Unlagged insulation conforming to EB Specification 4013 shall be sealed with one coat of Devco and Raynolds "DEVLEX 601" or Ocean 634 or



TABLE S1.1 Insulation and Lagging Materials^A

Service	Temperature Range, °F (°C)	Pipe and Tubing		Valve and Fittings		Flange Joints		Machinery	
		Insulation	Lagging	Insulation ^B	Lagging ^C	Insulation ^{C,D}	Lagging ^C	Insulation	Lagging
Gasses, steam, hot water, oil	125 to 1200 (52 to 649)	MIL-I-2781	MIL-C-20079	MIL-I-2781 ^I	MIL-C-20079	MIL-I-2781 ^I	MIL-C-20079	MIL-I-2819 ^I	MIL-C-20079
		MIL-C-20079 ^{E,F} and MIL-I-16411 MIL-I-22344 ^G (370°F [188°C] max) EB Specification 4013 (180°F [82°C] max) DoD-I-24688 ^H (370°F [188°C] max)		MIL-I-2819 ^I Class 2 MIL-C-2861 ^I MIL-C-20079 ^E and MIL-I-16411 MIL-I-22344 ^G (370°F [188°C] max) EB Specification 4013 (180°F [82°C] max) MIL-I-22023 (400°F [204°C] max) DoD-I-24688 ^H (370°F [188°C] max)		MIL-I-2819 ^I Class 2 MIL-C-2861 ^I MIL-C-20079 ^E and MIL-I-16411 MIL-I-22344 ^G (370°F [188°C] max) EB Specification 4013 (180°F [82°C] max) DoD-I-24688 ^H (370°F [188°C] max)		MIL-I-2819 ^I Class 2 MIL-I-16411 MIL-I-2818 (1000°F [538°C] max) MIL-C-2861 MIL-I-22023 (400°F [204°C] max) DoD-I-24688 ^H (370°F [188°C] max)	
Cold water, chilled water	28 to 99 (-2 to 37)	EB Specification 4013	MIL-C-20079 ^J	EB Specification 4013	MIL-C-20079 ^J	EB Specification 4013	MIL-C-20079 ^J	MIL-I-22023 EB Specification 4013	MIL-C-20079 ^J UU-B-790, Type III, Grade F, Style 10 MIL-C-20079 ^J
Refrigerant	-20 to 40 (-29 to 4)	EB Specification 4013	MIL-C-20079 ^J	EB Specification 4013	MIL-C-20079 ^J	EB Specification 4013	MIL-C-20079 ^J	EB Specification 4013	MIL-C-20079 ^J

^AAdditional materials are covered in S1.19 (metal lagging); S1.23 (fabrication, piping components); S1.25.4 (boiler uptakes); S1.26 (securing antisweat insulation); S1.28 (weather deck hot piping).

^BAlternatively, preformed mineral wool insulation with a hard fibrous glass cover (CADAFIT 1200°F [649°C]) or equal manufactured by Hamfab, Inc. Lehigh, PA may be used as applicable.

^CAlternatively, silicone rubber/aluminized fibrous glass cloth or silicone rubber-coated fibrous glass cloth may be used as applicable. The NAVSEA-approved sources of supply for each type are as follows. Silicone rubber/aluminized fibrous glass cloth: Alpha lightweight, 2337-2-AMA or equal and heavyweight 2025-2-AMA or equal, as applicable, manufactured by Alpha Associates, Inc., Woodbridge, NJ 07095 and 3M SRGA-0214 or equal manufactured by Minnesota Mining and Manufacturing Co., St. Paul, MN 55144. Silicone rubber-coated fibrous glass cloth: Claremont Scuffcoat or equal manufactured by the Claremont Co., Meriden, CT 06450 and Alpha 8359-2-SS or equal manufactured by Alpha Associates, Inc., Woodbridge, NJ 07095.

^DFlammable liquid flanges shall not be lagged (see Specification F 1138).

^EUsed only as a laminate construction consisting of a glass fabric outer jacket with a fibrous glass felt insert. An inner jacket of 0.008-in. (0.210-mm) knitted stainless steel mesh sewn on to fibrous glass cloth is used where pads or thermal insulation tape are needed and where the temperature of the hot surface is 450°F (232°C) or above. Alternatively, the inner jacket may be made from material conforming to HH-P-31, Type I, Class 1. (See Tables S1.2 and S1.6).

^FTo be used only on a temporary basis, such as replacement of permanent insulation damaged while a ship is at sea.

^GMIL-I-22344 insulation shall not be installed on hot piping above 1-in. (25-mm) nominal pipe size (NPS). Additionally, this insulation shall be installed only on piping with a vertical orientation or in "low-traffic" areas.

^HDoD-I-24688, Type I.

^IUse of MIL-2781, MIL-I-2819, and MIL-C-2861 on systems below 250°F (121°C) and in the presence of water may cause corrosion.

^JRewettable lagging in accordance with MIL-C-20079, Type I, Class 6 or 8 and manufactured by BGF Industries or Alpha Maritex Style 2014/9485 RW manufactured by Alpha Associates are the laggings qualified for fire performance with insulation conforming to EB Specification 4013.

equal to ensure that the insulation seals remain tight. Both unlagged EB Specification 4013 insulation sealed with "DEV-LEX 601" or Ocean 634 or equal and lagged insulation shall be painted with fire-retardant paint conforming to DoD-E-24607 or modified alkyd fire-retardant paint, Ocean 9788, or water-base DoD-C-24596 or Navy formula 25A.

S1.12 The use of "other materials" (provided the requirements of this practice are satisfied) does not apply to U.S. Navy vessels. See 4.1, Footnote B to Table 1, Footnote A to Table 2, and Footnote B to Table 3.

S1.13 Footnote A to Table 1 and Table 3 does not apply to U.S. Navy vessels.

S1.14 MIL-P-15280 shall not be used on naval vessels; alternatives are as follows:

S1.14.1 For Temperature Ranges:

20 to 100°F (29 to 38°C)	EB 4013
100 to 180°F (39 to 82°C)	EB 4013 and DoD-I-24688, Type I, and MIL-I-22344 (see Tables S1.4 and S1.6)
180 to 370°F (83 to 188°C)	DoD-I-24688, Type I and MIL-I-22344 (see Tables S1.4 and S1.6)

S1.15 The U.S. Navy limits the use of polyimide foam to 370°F (188°C).

S1.16 *Special Conditions*—The following special conditions supplement or modify the selection of materials or thicknesses specified, when applicable:

S1.16.1 The insulation thickness on soot blower piping between the root valve and the soot blower heads shall be reduced to one half that indicated for a system normally at the same temperature.

S1.16.2 For repair or replacement of piping and machinery insulation, only the materials specified herein shall be used.



TABLE S1.2 Thickness of Insulating Materials for Hot Surfaces of Valves and Fittings up to 1200°F (649°C)^A

Maximum Operating Temperature °F (°C)	Nominal Thickness, in. (mm) (does not include finishing cement or outer cover)				
	MIL-C-20079, Plus Fibrous Glass Felt MIL-I-16411 ^{B,C,D}	Insulation, Block MIL-I-2819 ^D	Insulating Cement MIL-C-2861 ^D	Polymide Foam, DoD-I-24688 ^D Type I	EB 4013 ^D to 180°F (82°C) Only
125 to 180 (52 to 82)				½ (13)	½ (13)
181 to 250 (83 to 121)				¾ (19)	
251 to 350 (122 to 177)				1 (25)	
351 to 370 (178 to 188)				1½ (38)	
125 to 338 (52 to 170)	1 (25)	1½ (38)	2 (51)		
339 to 388 (171 to 198)	1½ (38)	2 (51)	2½ (63)		
389 to 500 (199 to 260)	2 (51)	2½ (63)	3½ (89)		
501 to 750 (261 to 399)	3 (76)	4 (102)	5 (127)		
751 to 850 (400 to 454)	4 (102)	5 (127)	5½ (140)		
851 to 950 (455 to 510)	4½ (114)	5 (127)	not to be used alone		
951 to 1050 (511 to 566)	5 (127)	5½ (140)	for temperatures above 850°F		
1051 to 1200 (567 to 649)	6 (152)	6½ (165)	(454°C)		

^AValves and fittings that are welded into the line are insulated permanently. Flanged valves and flanged fittings shall have reusable covers to permit servicing of takedown joints. The valves in main and auxiliary steam systems from the valve bonnet up to the packing gland shall be insulated with reusable covers. The packing gland shall remain visible (see S1.22 and S1.23).

^BAlternatively, MIL-C-20079 plus CADAFIT 1200°F (649°C) or equal mineral wool insulation (with a hard fibrous glass cover) manufactured by Hamfab, Inc., Leighton, PA may be used as applicable.

^CReusable covers may also be fabricated using silicone rubber/aluminized fibrous glass cloth or silicone rubber-coated fibrous glass cloth, as applicable. The NAVSEA-approved sources of supply for each type are as follows. Silicone rubber/aluminized fibrous glass cloth: Alpha lightweight, 2337-2-AMA or equal and heavyweight 2025-2-AMA or equal as applicable, manufactured by Alpha Associates, Inc., Woodbridge, NJ 07095 and 3M SRGA-0214 or equal manufactured by Minnesota Mining and Manufacturing Co., St. Paul, MN 55144. Silicone rubber-coated fibrous glass cloth: Claremont Scuffcoat or equal manufactured by the Claremont Co., Meriden, CT 06450 and Alpha 8359-2-SS or equal manufactured by Alpha Associates, Inc., Woodbridge, NJ 07095.

^DUnless otherwise noted, blank spaces in table columns indicate temperature ranges in which other insulation materials are preferred.

TABLE S1.3 Thickness of Insulating Materials for Hot Surfaces of Machinery and Equipment^A

Maximum Operating Temperature °F (°C)	Nominal Thickness, in. (mm)					
	MIL-C-20079 ^B , Plus Fibrous Glass Felt MIL-I-16411 ^B	Insulation, Block MIL-I-2819 ^B	Mineral Fiber MIL-I-2818	Insulating Cement MIL-C-2861 ^B	Polymide Foam, DoD-I-24688 ^B Type I	EB 4013 ^B to 180°F (82°C) Only
125 to 180 (52 to 82)					½ (13)	½ (13)
181 to 250 (83 to 121)					¾ (19)	
251 to 350 (122 to 177)					1 (25)	
351 to 370 (178 to 188)					1½ (38)	
125 to 338 (52 to 170)	1 (25)	1½ (38)	1½ (38)	2 (51)		
339 to 388 (171 to 198)	1½ (38)	2 (51)	2 (51)	2½ (63)		
389 to 500 (199 to 260)	2 (51)	2½ (63)	2½ (63)	3½ (89)		
501 to 750 (261 to 399)	3 (76)	4 (102)	4 (102)	5 (127)		
751 to 850 (400 to 454)	4 (102)	5 (127)	5 (127)	5½ (140)		
851 to 950 (455 to 510)	4½ (114)	5 (127)	5 (127)	not to be used alone		
951 to 1050 (511 to 566)	5 (127)	5½ (140)	5½ (140)	for temperatures		
1051 to 1200 (567 to 649)	6 (152)	6½ (165)	(1000°F [538°C] max)	above 850°F (454°C)		

^ADoes not include finishing cement.

^BUnless otherwise noted, blank spaces in table columns indicate temperature ranges in which other insulation materials are preferred.

Procedures for the repair and replacement of insulation are contained in Naval Ships Technical Manual (NSTM), Chapter 635.

S1.16.3 Where hot-surface insulation thicknesses are not specified, and for special applications, the insulation thickness shall be sufficient to reduce the insulation surface temperature to the values shown in 5.2.

S1.16.4 Adhesives containing halogenated solvents shall not be used for submarine applications.

S1.16.5 Insulation shall not be installed on 2 ft of pipe immediately upstream of thermostatic steam traps, complying with MIL-T-2118. A removable cover, consisting of two layers of glass cloth, shall be installed over the uninsulated pipe and the thermostatic trap.

S1.16.6 Small diameter hot piping, ½-in (15-mm) nominal pipe size (NPS) and under shall not be insulated when the

operating temperatures are less than 125°F (52°C).

S1.16.7 Shielding on uninsulated hot pipes shall be provided only where such pipes are readily accessible to contact with personnel.

S1.16.8 MIL-I-2781 shall be used in “high traffic” areas on hot piping whose design temperature is greater than 180°F (82°C). “High traffic” areas are those areas in which the installed insulation and lagging will be subject to wear and damage during routine operations. Alternatively, DoD-I-24688 can be used on hot piping in “high traffic” areas that are in a vertical orientation.

S1.16.9 It is recommended not to use these insulation materials on austenitic stainless steel components without a corrosion study.

S1.17 Adhesives:

S1.17.1 Adhesives conforming to MIL-A-3316 shall be



TABLE S1.4 Thickness of Insulation Conforming to EB Specification 4013, DoD-I-24688, and MIL-I-22344, for Hot Piping

Maximum Operating Temperature Range, °F (°C)	Specification	Nominal Thickness, in. (mm)
125 to 180 (52 to 82)	MIL-I-22344 ^{A,B}	1/2 (13)
	EB Specification 4013	
181 to 250 (83 to 121)	DoD-I-24688, Type I	1/2 (13)
	MIL-I-22344 ^{A,B}	
	DoD-I-24688, Type I	
251 to 300 (122 to 149)	MIL-I-22344 ^{A,B}	3/4 (19)
	DoD-I-24688, Type I	3/4 (19)
301 to 350 (150 to 177)	DoD-I-24688, Type I	1 (25)
	MIL-I-22344 ^{A,B}	1 (25)
351 to 370 (178 to 188)	DoD-I-24688, Type I	1 (25)
	MIL-I-22344 ^{A,B}	1 1/2 (38)

^AShall only install on piping no greater than 1 in. (25 mm) NPS (for surface ships only).

^BShall not be installed in designated "high traffic" areas unless in a vertical orientation.

TABLE S1.5 Thickness of Insulation for Hot Piping Conforming to MIL-I-2781

Nominal Pipe Size, in. (mm)	Temperature Range, °F (°C)	Nominal Thickness Total ^{A,B} , in. (mm)
1/2, 1 1/2 (13, 38)	125–388 (53–198)	1 1/2 (38)
	389–750 (199–399)	2 1/2 (63)
	751–950 (400–510)	3 (76)
	951–1050 (511–566)	4 (102)
2, 2 1/2 (51, 63)	125–338 (52–170)	1 1/2 (38)
	339–388 (171–198)	2 (51)
	389–900 (199–482)	3 (76)
	901–1050 (483–566)	4 (102)
3–4 1/2 (76–114)	125–338 (52–170)	1 1/2 (38)
	339–388 (171–198)	2 1/2 (63)
	389–500 (199–260)	3 (76)
	501–900 (261–482)	3 1/2 (89)
	901–950 (483–510)	4 (102)
	951–1050 (511–566)	4 1/2 (114)
5, 6, 7 (127, 152, 178)	125–338 (52–170)	1 1/2 (38)
	339–388 (171–198)	2 1/2 (63)
	389–750 (199–398)	3 1/2 (89)
	751–900 (399–482)	4 (102)
	901–950 (483–510)	4 1/2 (114)
	951–1050 (511–566)	5 1/2 (140)
8 (203) or larger	125–338 (52–170)	1 1/2 (38)
	339–388 (171–198)	2 1/2 (63)
	389–500 (199–260)	3 1/2 (89)
	501–750 (261–398)	4 (102)
	751–900 (399–482)	4 1/2 (114)
	901–950 (483–510)	5 (127)
	951–1050 (511–566)	6 (152)

^ADoes not include finishing cement.

^BWherever possible, double layers shall be used where temperatures exceed 600°F (316°C). Double layers may be used at temperatures below 316°C.

used for fastening fibrous glass cloth and tape lagging only in inaccessible areas or where rewettable lagging cannot be applied. The MIL-C-20079, Type I, Class 6 and 8 fibrous glass cloth with pre-applied rewettable adhesive manufactured by BGF Industries, 3802 Robert Porcher Way, Greensboro, NC 27410 or Alpha Maritex Style 2014/9485 RW manufactured by Alpha Associates is an alternative and preferred system to the fibrous glass cloth adhered with MIL-A-3316 adhesive for lagging. However, it is not recommended for use in areas subject to live steam or dampness.

S1.17.2 Rubatex R373 and Armstrong 520 are the only adhesives to secure EB Specification 4013 insulation to itself and to metals for surface ships and submarines.

TABLE S1.6 Thickness of Insulating Tape Conforming to MIL-C-20079 and MIL-I-16411 for 1/4 to 3/4-in. (8 to 20-mm) NPS Size Hot Piping^{A,B}

Maximum Operating Temperature Range, °F (°C)	NPS Pipe Size, in. (mm)	Nominal Thickness, in. (mm)
125 to 250 (49 to 121)	1/4, 3/8 (6, 10)	3/8 (10)
251 to 750 (122 to 399)	1/4, 3/8 (6, 10)	1 1/2 (38)
125 to 350 (49 to 177)	1/2, 3/4 (13, 19)	1/2 (13)
351 to 388 (178 to 198)	1/2, 3/4 (13, 19)	1 (25)
389 to 500 (199 to 260)	1/2, 3/4 (13, 19)	1 1/2 (38)
501 to 750 (261 to 399)	1/2, 3/4 (13, 19)	2 (51)

^ATo be used only on a temporary basis, such as repair of insulation while ship is at sea. Insulation tape shall be replaced by NAVSEA-approved preformed sectional pipe insulation at the earliest opportunity.

^BUsed only as a laminate construction consisting of a glass fabric outer jacket with a fibrous glass felt insert. An inner jacket of 0.008-in. (0.203-mm) crimped stainless steel mesh is used where pads of thermal insulation tape are needed and where the temperature of the hot surface is 450°F (232°C), or above. Alternatively, pads may be made from material conforming to HH-P-31, Type I, Class 1.

S1.17.3 Sodium silicate solution, Specification D 3400, shall be used as an adhesive for joining segments of calcium silicate preformed pipe insulation in accordance with MIL-I-2781.

S1.18 *Finishing/Insulation Cements*—Where finishing and insulating cements are specified, any of the following materials are acceptable. Before use, material compatibility with the proposed application will be verified.

S1.18.1 Hydraulic-setting mineral fiber finishing and insulating cement in accordance with Specification C 449/C 449M.

S1.18.2 High-temperature insulating cement in accordance with MIL-C-2861, when used under fibrous glass cloth.

S1.19 *Metal Lagging*—Where metal lagging is required, any of the following materials are acceptable, except for uptake applications (see S1.25.4.1):

Sheet Material	Specification	Nominal Thickness, in. (mm)
Hot-dipped galvanized steel	ASTM A 526/A 526M Coating Designation G-115	0.014 (0.356)
Aluminum	ASTM B 209/B 209M, 6061	0.030 (0.762)
Corrosion-resistant steel	ASTM A 167, Type 304	0.014 (0.356)

S1.20 *Fasteners*—Insulation shall be held in place by suitable wire or flat metal bands. The welding of fasteners to machinery, piping, pressure vessels, or other related equipment is prohibited. Where fasteners are necessary, they shall be attached during manufacture (before heat treatment, stress relief, and testing) by a NAVSEA-approved procedure.

S1.21 *Hot-Surface Insulation Covers*—To ensure that the pipe covering will not interfere with the servicing of a takedown joint where a reusable cover is installed, the permanent insulation shall stop short of the takedown joint and a short removable and reusable section of insulation shall be installed between the permanent insulation and the takedown joint. The insulation joint formed by the permanent and reusable sections shall be square, or at an angle of 45°. The reusable section shall fit tightly at the interfacing joint without gaps and shall be held in place with removable pins, clips, wire, or bands to maintain a tight joint.

S1.22 *Construction*—For sizes larger than 2-in. (50-mm) NPS, valve bonnets and valves having takedown joints at the



ends shall be fitted with reusable covers such that the bonnet joint may be removed independently of the valve covering. Valves, not greater than or equal to 2-in. NPS, shall be fitted with separate covers as indicated previously, or covers of a one-piece design such that they may be wrapped around the entire valve body and clipped or otherwise secured just below the packing gland on the valve stem. The packing gland shall remain visible.

S1.23 Fabrication, Piping Components—For piping components except as otherwise specified, any one of the following methods of fabrication is acceptable.

S1.23.1 Covers for Piping Components—Covers that are exposed to temperatures under 450°F (232°C) may be made in two half sections, using fibrous glass felt in accordance with MIL-I-16411 enclosed in fibrous glass fabric conforming to MIL-C-20079, Type I, Class 9. Alternatively, silicone rubber-coated, or silicone rubber/aluminized glass fabric¹³ may be substituted for plain fibrous glass fabric for the cover material. Covers that are exposed to temperatures of 450°F (232°C) and over shall have a 0.008-in. (0.203-mm) diameter knitted stainless steel wire mesh sewn on to the fibrous glass cloth on the inside (hot) surface and on the ends. Alternatively, the inside surface and ends of pads may be fabricated of wire-reinforced fibrous glass cloth conforming to HH-P-3 I, Type I, Class I. Each half cover shall be sewn and quilted with polytetrafluoroethylene (PTFE) coated fibrous glass yarn conforming to MIL-C-20079, Type III, Classes 3, 4, or 6 for hand sewing or PTFE-coated fibrous glass sewing thread (fully sintered), Type III, Class 3, 5, or 6 for machine sewing. The covers may also be fastened by mechanical stapling with galvanized or stainless steel staples in a manner to provide uniform thickness, strength, and rigidity.

S1.23.1.1 Wire Mesh—Knitted wire mesh shall be of 304 annealed stainless steel. The wire shall be 0.008-in. diameter. The mesh shall consist of $7\frac{1}{2} \pm \frac{1}{2}$ in. (188 ± 13 mm) courses per inch equal spacing and 10 ± 1 wales per inch equal (3.9 ± 0.5 wales per cm) spacing. The mesh shall be furnished in $30 \pm \frac{1}{2}$ in. ($750 \text{ mm} \pm 13 \text{ mm}$) flattened tubular form and shall be crimped 0.125 to 0.150 in. (3.18 to 3.81 mm) deep by $\frac{5}{16}$ in. (7.94 mm) crimp to crimp.

S1.23.2 Preformed Covers—Preformed fibrous glass or polyimide foam, DoD-I-24688, Type I valve or fitting covers shall be used when temperatures are in the 125 to 370°F (52 to 188°C) range. These shall be of the same thickness as the adjacent pipe covering. Such covers, when used, shall be lagged independently of the pipe covering and in a manner that will facilitate removal and replacement.

S1.23.3 Block and Preformed Insulation—Covers shall be made of segments of block insulation or preformed pipe

insulation, having the same thickness as that on the adjacent piping. Blocks shall be securely wired to frames of ½-in. square mesh, 300 Series stainless steel wire with a diameter of 0.0403 in. (1.024 mm). Wire mesh frames inside and outside of blocks shall have ends bent over and joints secured with Number 18 gage black annealed iron wire woven through the mesh. High-temperature cement in accordance with MIL-C-2861 shall be troweled smoothly over all surfaces of the wire mesh. Fibrous glass felt in accordance with MIL-I-16411 may be used to build up covers when the flange diameter is larger than the outside diameter of the adjacent pipe covering. Covers shall be tightly and smoothly lagged to envelop the outside and ends, using fibrous glass cloth conforming to MIL-C-20079, Type I, Class 9. Lagging shall be either cemented or sewn on, except the ends of covers, which shall always be sewn. Where double-layer insulation is used, the two sections of the cover shall be fitted together with a scarfed joint. Such joints shall be straight and true to reduce heat loss. Bands; eyelets or locks of galvanized steel; or lacing with hooks, rings, washers, and wire shall be used to secure the covers.

S1.23.4 Felt—When installing the preceding covers, spaces between inner surfaces of covers for flanges and other irregular surfaces shall be filled with pieces of fibrous glass insulation felt in accordance with MIL-I-16411. Felt shall be packed loosely enough to preserve air cell structure and tightly enough to prevent air circulation.

S1.23.5 Mineral Fiber (Rock/Slag)—Preformed mineral fiber (rock/slag) insulation with a hard fibrous glass cover (CADAFIT 1200°F [649°C]) or the equivalent may be used as applicable. For the appropriate thickness of CADAFIT 1200°F or the equivalent mineral fiber (rock/slag) insulation, refer to the thicknesses shown in Table S1.2 at the appropriate temperature range.

S1.24 Fabrication, Machinery, and Equipment—For reusable covers for machinery and equipment, either of the following methods of fabrication is acceptable.

S1.24.1 Machinery and Equipment Covers—Covers similar to fibrous glass felt in accordance with MIL-I-16411 described for piping components (see S1.23.1).

S1.24.2 Covers Formed from Block Insulation—Covers made in sections formed of insulating block held together with wire and adhesive cement, covered with ½-in. (13-mm) thickness of finishing cement, Specification C 449/C 449M and lagged. Lacing with hooks, rings, washers, and wire or brass snap fasteners shall be used to secure the covers.

S1.24.3 Semiremovable Turbine Covers—Semiremovable turbine casing flange covers may be installed as an alternative for removable covers previously specified. The permanent insulation shall be run to the casing flange, allowing for bolt removal space. The flange and bolts shall be covered with (1) fibrous glass cloth in accordance with MIL-C-20079, Type I; (2) wire inserted fibrous glass cloth in accordance with HH-P-31, Type I, Class 1; or (3) knitted wire mesh, as required by operating temperature. The chosen cover shall be secured to the bolts with wire. The flange shall then be insulated with fibrous glass felt in accordance with MIL-I-16411, mineral wool felt in accordance with MIL-I-2818, or insulation block in accordance with MIL-I-2819, Class 2 to the required

¹³ Alternatively, silicone rubber-coated fibrous glass cloth or silicone rubber/aluminized fibrous glass cloth may be used as applicable. The NAVSEA-approved sources of supply for each type are as follows: Silicone rubber-coated fibrous glass cloth—Claremont Scuffcoat or equal manufactured by The Claremont Co., Meriden, CT 06450 and Alpha 8359-2-SS or equal manufactured by Alpha Associates, Inc., Woodbridge, NJ 07095. Silicone rubber/aluminized fibrous glass cloth—Alpha lightweight 2337-2-AMA or equal and heavyweight 2025-2-AMA or equal as applicable, manufactured by Alpha Associates, Inc., Woodbridge, NJ 07095 and 3M SRGA-0214 or equal manufactured by Minnesota Mining & Manufacturing Co., St. Paul, MN 55144.



thickness and shape. The insulation is then lagged with fibrous glass cloth, which shall be carried over the outer edge of the permanent insulation and secured with adhesive. The semiremovable cover shall then be sealed with adhesive in accordance with MIL-A-3316, Class 1, and painted.

S1.25 Hot-Surface Insulation:

S1.25.1 Pipe and Tubing—Each layer of molded insulation shall be installed with joints butted together. Where two layers are used, joints shall be staggered. Not less than three fastenings shall be used to secure each 3-ft section of insulation. Fastening shall be Number 18 gage minimum (0.049-in. [1.245-mm] diameter) annealed black iron or 300 Series stainless steel wire with a diameter of 0.0403-in. (1.024-mm) wire or flat steel bands. Except as otherwise specified, lagging shall be installed over the insulation.

S1.25.1.1 Preformed Polyimide Pipe Covers—Preformed polyimide pipe covering conforming to DoD-I-24688, Type I, shall be lagged or prelagged with MIL-C-20079 fibrous glass cloth facing on piping systems whose design temperature is between 100 and 370°F (38 to 188°C).

S1.25.1.2 Soot Blower Piping—The installation of soot blower piping insulation shall be in accordance with Drawing 804-841336.

S1.25.2 Piping Components—Valves, fittings, and accessories with welded and brazed fittings including unions, may be insulated and lagged similarly to adjacent piping.

S1.25.2.1 Block, Felt, Molded Insulating Materials—Block or felt insulating materials, or molded pipe insulation secured with hot-dipped galvanized iron or steel wire, shall be used. When insulating felts are used, the inner layer shall be fibrous glass felt conforming to MIL-I-16411. Galvanized iron or steel wire netting, Number 18 gage minimum (0.049-in. [1.245-mm] diameter), shall be spread over the insulating material and secured with wire. Insulating cement shall be used to fill crevices, smooth surfaces, and completely cover the wire netting. A ½-in. (13-mm) thickness of finishing cement shall then be applied. Alternatively, wire netting may be omitted where the size of the installation does not require netting to hold the insulation cement in place during the installation process. For these installations, glass cloth may be installed over the previously finished insulation material without the intermediate layer of wire mesh. Insulating material shall be the same thickness as that on adjacent piping.

S1.25.2.2 Reusable Covers—Reusable covers shall be fitted where required.

S1.25.3 Machinery and Equipment—For machinery and equipment, block, felt, or blanket insulating materials of the required thickness shall be secured with “GB” (galvanized before weaving) iron wire, “GB” galvanized iron wire netting, 1-in. (25-mm) mesh and 20- to 22-gage minimum (0.88- to 0.73-mm diameter), shall be spread over the surface and secured by wire. Insulating cement shall be used to fill crevices, smooth surfaces, and completely cover the wire netting. Use stainless steel wire netting, Type 304 (20 gage) for temperatures above 370°F (188°C).

S1.25.3.1 Use of Finishing Cement—When no insulating cement has been specified, a ½-in. (13-mm) thickness of finishing cement shall be applied.

S1.25.3.2 Insulating Cement—When insulating cement has been specified, it shall be applied in successive layers, ½ to 1 in. (13 to 25 mm) in thickness, until the total thickness specified has been reached. Wire netting, similar to that used for covering the insulating materials shall be installed between layers. A ½-in. (13-mm) thickness of finishing cement shall be applied over the last layer of insulating cement.

S1.25.3.3 Lagging—Lagging shall be installed over finishing cement. Reusable covers shall be installed where required.

S1.25.3.4 Fastenings—Clips, hooks, or other fastenings for securing insulation or lagging shall not be brazed or welded to nonferrous parts of distilling plants or deaerating feed tanks.

S1.25.4 Boiler Uptakes—Boiler uptake thermal insulation shall be insulated with either mineral wool felt in accordance with MIL-I-2818 or fibrous glass felt in accordance with MIL-I-16411. If acoustic absorptive treatment is found to be necessary to decrease the noise level, the insulation thickness shall be increased accordingly.

S1.25.4.1 Metal Lagging—Metal lagging for uptakes shall be galvanized sheet steel conforming to Specification A 653/A 653M Coating Designation G-115, not less than ⅓ in. (0.794 mm) thick.

S1.25.4.2 Exceptions—Insulation and lagging is not required on uptakes above the weather deck, except where the transfer of heat to spaces adjacent to the uptake area would be objectionable.

S1.25.5 Unfired Pressure Vessels—Unfired pressure vessels, including catapult wet accumulators, shall be covered with block insulation, MIL-I-2819, or fibrous glass felt in accordance with MIL-I-16411. Insulation shall be held in place with 18-gage galvanized wire spaced on approximately 3-in. (75-mm) centers or steel strapping spaced on not greater than 9-in. (225-mm) centers. Insulation shall be covered with ½-in. (13-mm) finishing cement in accordance with Specification C 449/C 449M, lagged with fibrous glass cloth in accordance with MIL-C-20079, Type I and painted as in accordance with S1.11. Insulation in the way of vessel supports shall be metal faced to prevent insulation from wedging between the vessel and its support.

S1.25.5.1 Removable and Reusable Covers—Removable and reusable covers shall be installed over butt-welded shell inserts for which periodic radiographic inspection of the joint is required. These covers shall extend 4 in. (100 mm) beyond the welded joint.

S1.25.6 Outer Boiler Casing—If insulation is specified by pertinent ship’s specification or contract, insulation block in accordance with MIL-I-2819, Class 2, shall be secured to casing by wire netting (20- to 22-gage [0.88- to 0.73-mm] diameter), GB/galvanized, 1-in. hexangle wire mesh laced to welded notched studs on the boiler casing. Finishing cement, Specification C 449/C 449M, shall be used to fill crevices, smooth surfaces, and completely cover the netting to ½-in. (13-mm) thickness. Glass cloth conforming to MIL-C-20079, Type I, class as applicable, shall be used to lag the insulation and shall be painted in accordance with S1.11.

S1.26 Antisweat Insulation (Cold and Chilled Water Service)—Antisweat piping insulation shall consist of preformed pipe insulation conforming to EB Specification 4013.



Thickness shall be $\frac{3}{4}$ in. on all pipe sizes, except in air-conditioned spaces, where thickness shall be $\frac{1}{2}$ in. (13 mm). On large pipe sizes, EB Specification 4013 insulation sheet form shall be applied in not less than $\frac{1}{4}$ -in. (6-mm) minimum thickness as necessary to build up to the required thickness. Glass cloth lagging shall be applied to protect insulation from damage in high traffic areas. Rewettable lagging in accordance with MIL-C-20079, Type I, Class 6 or 8, and manufactured by BGF Industries or Alpha Maritex Style 2014/9485 RW manufactured by Alpha Associates are the laggings qualified for fire performance for use with insulation conforming to EB Specification 4013.

S1.27 Refrigerant Insulation—Insulation in accordance with EB Specification 4013 shall be applied in not less than $\frac{1}{4}$ -in. (6-mm) thickness layers as necessary to build up the required thickness (tubular or sheet, as applicable). Longitudinal and butt joints shall be staggered. Joints shall be sealed using adhesive conforming to MIL-A-24179. Glass cloth lagging shall be applied over insulation in high traffic areas to protect against damage. Rewettable lagging in accordance with MIL-C-20079, Type I, Class 6 or 8, and manufactured by BGF Industries or Alpha Associates are the laggings qualified for fire performance for use with insulation conforming to EB Specification 4013.

S1.28 Weather Deck Hot Piping Insulation—Sectional preformed calcium silicate (MIL-I-2781) insulation for piping exposed to the weather shall be installed as follows:

S1.28.1 Preliminary Preparation Piping:

S1.28.1.1 All surfaces shall be clean, dry, and free of scale and grease.

S1.28.1.2 Fittings, valves, flanges, pipe supporting clamp, and not less than 3 in. (75 mm) of adjacent pipe shall be painted as follows: Apply one coat pretreatment formula 117 in accordance with DoD-C-15328 to a dry film thickness (DFT) of not greater than 0.0005 in. (0.0127 mm) (0.5 mil). After this coat dries, apply two coats of aluminum paint made by mixing 2 lb of aluminum paste in accordance with Specification D 962, with each gallon of phenolic varnish for temperatures up to 300°F (149°C). For temperatures above 300°F, apply two coats of paint conforming to TT-P-28.

S1.28.2 Installation on Pipes:

S1.28.2.1 Longitudinal joints on horizontal piping shall be on the top and bottom of the pipe; joints shall be staggered.

S1.28.2.2 Insulation shall be secured tightly to pipe with $\frac{1}{2}$ -in. (13-mm) wide 22-gage galvanized steel bands or 18-gage galvanized iron wire on 9-in. (225-mm) centers.

S1.28.2.3 Fill all joints and voids in the insulation with high-temperature cement in accordance with MIL-C-2861. Wrap tightly with one layer of fibrous glass lagging cloth in accordance with MIL-C-20079, Type I, using adhesive in accordance with MIL-A-3316, Class 1. After the adhesive has dried, the lagging shall be coated with two brush coats of end sealing compound in accordance with MIL-C-22395.

S1.28.2.4 Where insulation is stopped off on the piping, the preformed insulation shall be tapered. The exposed surface and

3 in. (75 mm) of pipe shall be coated with sealing compound in accordance with MIL-C-22395. Fibrous glass lagging cloth, in accordance with MIL-C-20079, Type I, class as applicable, tailored to fit over the tapered insulation and exposed pipe shall be applied while the end sealing compound is still tacky. The lagging shall be attached to the insulation using adhesive in accordance with MIL-A-3316, and to the pipe with a $\frac{1}{2}$ -in. (13-mm) wide 22-gage galvanized steel band.

S1.28.3 Installation on Fittings, Flanges, and Valves:

S1.28.3.1 Before applying flange insulation, weather deck piping shall be tested and secured in the following manner: After specified tests are completed, weather deck piping shall be subjected to alternate periods of full operating pressure, allowing pipe to come to maximum temperature, and then to zero gage pressure allowing pipe to come to ambient temperature. These cycles shall be repeated a sufficient number of times, with tightening and adjusting flanges where necessary, until no leaks can be detected.

S1.28.3.2 Fittings, flanges, and valve covers shall be ship fabricated from sections of molded pipe covering block cemented together with adhesive in accordance with Specification D 3400.

S1.28.3.3 Permanent covers for fittings and valves shall be fitted snugly to fittings and adjacent pipe covering using the same material and methods as outlined for pipe covering. Voids between insulation and fitting shall be filled with tightly packed fibrous glass felt in accordance with MIL-I-16411. Permanent covers shall be lagged and coated in the same manner as the adjacent piping insulation.

S1.28.3.4 Where specified, rigid-type removable flange covers shall extend over the adjacent pipe covering $1\frac{1}{2}$ times the thickness of the insulation. The two halves of the cover shall be coated and lagged separately, using the same materials and procedure as outlined for weather deck hot pipe covering. The galvanized steel bands used to secure the two halves together and to the adjacent pipe covering shall be applied over the lagging and then coated with the end sealing compound in accordance with MIL-C-22395.

S1.28.4 Installation Around Supports and Hangers—Remove only enough insulation from butt edges to provide a snug fit around support brackets or hanger rods. Fill voids between insulation and support with tightly packed fibrous glass felt in accordance with MIL-I-16411 to within $\frac{1}{4}$ in. (6 mm) from insulation surface. Fill the remainder of space with sealing compound, in accordance with MIL-C-22395, overlapping generously both the support member and the adjacent insulation. Lag and coat with the same method and materials as adjacent piping.

S1.29 Metal Lagging—Metal lagging, where required, shall be installed with lap joints, secured with hardened self-tapping screws (not to be used for below ambient conditions) or metal bands. Joints shall be arranged in a manner which will facilitate run off of impinging liquids.



F 683

APPENDIX

(Nonmandatory Information)

X1. RATIONALE

X1.1 This Appendix provides general background information for this practice which is an adaptation of the former MIL STD 769, Thermal Insulation Requirements for Machinery and Piping. The intent of this practice is to provide general guidance describing commercial ship thermal insulation requirements in the main body and military ship requirements in the Supplementary Requirements section. Note that some

military specifications and standards are referenced in the main body since there are no approved ASTM equivalents at this time. As ASTM equivalents for these military documents are approved, they will be substituted in the main body, and eventually, the military documents will be purged from this ASTM Practice.

ASTM International takes no position respecting the validity of any patent rights asserted in connection with any item mentioned in this standard. Users of this standard are expressly advised that determination of the validity of any such patent rights, and the risk of infringement of such rights, are entirely their own responsibility.

This standard is subject to revision at any time by the responsible technical committee and must be reviewed every five years and if not revised, either reapproved or withdrawn. Your comments are invited either for revision of this standard or for additional standards and should be addressed to ASTM International Headquarters. Your comments will receive careful consideration at a meeting of the responsible technical committee, which you may attend. If you feel that your comments have not received a fair hearing you should make your views known to the ASTM Committee on Standards, at the address shown below.

This standard is copyrighted by ASTM International, 100 Barr Harbor Drive, PO Box C700, West Conshohocken, PA 19428-2959, United States. Individual reprints (single or multiple copies) of this standard may be obtained by contacting ASTM at the above address or at 610-832-9585 (phone), 610-832-9555 (fax), or service@astm.org (e-mail); or through the ASTM website (www.astm.org).