



Standard Practice for Selection and Application of Thermal Insulation for Piping and Machinery¹

This standard is issued under the fixed designation F 683; the number immediately following the designation indicates the year of original adoption or, in the case of revision, the year of last revision. A number in parentheses indicates the year of last reapproval. A superscript epsilon (ϵ) indicates an editorial change since the last revision or reapproval.

This standard has been approved for use by agencies of the Department of Defense.

1. Scope

1.1 This practice provides guidance in the selection of types and thicknesses of thermal insulation materials for piping, machinery, and equipment for nonnuclear shipboard applications. Methods and materials for installation, including lagging, are also detailed.

1.2 Supplemental requirements and exceptions to the requirements discussed herein for vessels of the U.S. Navy are included in Annex A1.

1.3 Asbestos or asbestos containing materials shall not be used.

1.4 The values stated in inch-pound units are to be regarded as the standard. The values given in parentheses are for information only.

1.5 *This standard does not purport to address all of the safety concerns, if any, associated with its use. It is the responsibility of the user of this standard to establish appropriate safety and health practices and determine the applicability of regulatory limitations prior to use.*

2. Referenced Documents

2.1 ASTM Standards:

- A 167 Specification for Stainless and Heat-Resisting Chromium-Nickel Steel Plate, Sheet, and Strip²
- A 526/A526M Specification for Steel Sheet, Zinc-Coated (Galvanized) by the Hot-Dip Process, Commercial Quality³
- B 209 Specification for Aluminum and Aluminum-Alloy Sheet and Plate⁴
- C 168 Terminology Relating to Thermal Insulating Materials⁵
- C 195 Specification for Mineral Fiber Thermal Insulating Cement⁵
- C 449/C449M Specification for Mineral Fiber Hydraulic-

Setting Thermal Insulating and Finishing Cement⁵

C 533 Specification for Calcium Silicate Block and Pipe Thermal Insulation⁵

C 547 Specification for Mineral Fiber Preformed Pipe Insulation⁵

C 552 Specification for Cellular Glass Thermal Insulation⁵

C 553 Specification for Mineral Fiber Blanket Thermal Insulation for Commercial and Industrial Applications⁵

C 610 Specification for Molded Expanded Perlite Block and Pipe Thermal Insulation⁵

C 612 Specification for Mineral Fiber Block and Board Thermal Insulation⁵

C 680 Practice for Determination of Heat Gain or Loss and the Surface Temperatures of Insulated Pipe and Equipment Systems by the Use of a Computer Program⁵

C 892 Specification for High-Temperature Fiber Blanket Thermal Insulation⁵

2.2 Federal Specification:⁶

DOD-I-24688 Insulation, polyimide pipe, anti-sweat and thermal sheet and tube

HH-P-31 Packing and Lagging Material, Fibrous Glass Metallic and Plain Cloth and Tape

2.3 Military Specifications:⁶

MIL-A-3316 Adhesive, Fire-Resistant, Thermal Insulation

MIL-A-24179 Adhesive, Flexible, Unicellular-Plastic, Thermal Insulation

MIL-C-19565 Coating Compounds, Thermal Insulation Pipe Covering—Fire and Water-Resistant Vapor Barrier and Weather Resistant

MIL-C-20079 Cloth, Glass, Tape, Textile Glass and Thread, Glass

MIL-C-22395 Compound, End Sealing, Thermal Insulation Pipe Covering—Fire, Water, and Weather Resistant

MIL-I-2781 Insulation, Pipe, Thermal

MIL-I-2818 Insulation Blanket, Thermal, Fibrous Material

MIL-I-2819 Insulation, Block, Thermal

MIL-I-16411 Insulation, Felt, Thermal, Glass Fiber

MIL-I-22344 Insulation, Pipe, Thermal, Fibrous Glass

MIL-P-15280 Plastic Material, Unicellular (Sheets and Tubes)

¹ This practice is under the jurisdiction of ASTM Committee F-25 on Ships and Marine Technology and is the direct responsibility of Subcommittee F25.02 on Insulation/Processes.

Current edition approved April 10, 1999. Published August 1999. Originally published as F 683 – 80. Last previous edition F 683 – 97.

² *Annual Book of ASTM Standards*, Vol 01.03.

³ *Discontinued 1994—Replaced by A 653/A 653M.*

⁴ *Annual Book of ASTM Standards*, Vol 02.02.

⁵ *Annual Book of ASTM Standards*, Vol 04.06.

⁶ Available from Standardization Documents Order Desk, Bldg. 4 Section D, 700 Robbins Ave., Philadelphia, PA 19111-5094, Attn: NPODS.

MIL-STD-769 Thermal Insulation Requirements for Machinery and Piping

2.4 *Other Documents:*

Title 46 Code of Federal Regulations (CFR), Shipping (Parts 164.012 and 164.112)⁷

USCG Equipment List CG 190-164.012 Interior Finish⁸

2.5 *Drawings, NAVSHIPS:*⁸

804-5959214 Piping Insulation, Installation Details

804-5959212 Machinery Insulation, Installation Details

2.6 *Drawing, NAVSEA:*⁸

803-5184182 Passive Fire Protection Insulation

3. Terminology

3.1 Definitions—For definitions of terms relating to insulating materials used in this practice, refer to Definitions C 168.

4. Materials and Manufacture

4.1 *Insulation and Lagging Material Specifications*, as listed in Tables 1-17, describe those materials which are intended for use in the indicated temperature ranges. The specifications and requirements outlined herein are not intended to prevent the use of new methods or materials, provided that sufficient technical data is submitted to demonstrate that the proposed method or material is equivalent in quality, effectiveness, durability, and safety to that prescribed by this practice.

5. General Requirements

5.1 Piping, including valves, fittings, and flanges conveying vapors, gases, or liquids that attain temperatures outside the range from 55 to 125°F (13 to 52°C) during normal operation, shall be insulated except as otherwise stated herein.

5.2 The insulation thicknesses specified in this practice are designed to maintain the surface temperature at or below 125°F (52°C) for fluid temperatures up to 650°F (343°C) with an ambient temperature of 85°F (29°C). For fluid temperatures above 650°F (343°C), the surface will be maintained at a maximum of 133°F (56°C).

5.2.1 Insulation thicknesses have been calculated using the computer programs in Practice C 680.

5.3 Piping and units of equipment with designated internal temperatures of 300°F (149°C) and over shall be insulated from their supports or the supports insulated from the structures to which they are attached where the heat transmitted may be objectionable on the opposite side of the structure.

5.4 Insulated piping passing through accommodation, service, and control spaces must be covered with approved incombustible materials which meet 46 CFR, Sections 164.009 and 164.012. Elastomeric foam plastic insulation shall not be used in these spaces.

5.5 Special consideration shall be given to the insulation of integral piping supplied with and mounted on equipment or machinery. In these cases, alternative materials and methods of installation may be considered provided that they comply with the performance requirements of this practice.

5.6 Minimum insulation requirements have not been established for those surfaces or applications where insulations had not been specified in past practices. In effect, the following surfaces are excluded from insulation requirements:

5.6.1 Surfaces where application of insulation would affect proper operation.

5.6.2 Equipment, components, and systems designed for the dispersion of heat.

5.6.3 Thermostatic steam traps and 24 in. (620 mm) of piping upstream of traps, which shall not be insulated. When located in areas where personnel protection is required, expanded metal shields or multilayer glass cloth shall be provided.

5.6.4 Mechanical joints exposed to subatmospheric pressures, and those included in the fuel oil service piping from heaters to burners.

5.6.5 Fuel oil piping between headers and burners.

5.6.6 Piping above 125°F (52°C) in bilges, not within watertight enclosures.

5.6.7 Piping in locations where sweating and possible resultant rust is not objectionable such as voids, bilges, and shaft alleys, plus plumbing fixtures and associated supply and drain piping immediately adjacent thereto.

5.6.8 Dead-end hot water piping 3/8 in. (10 mm) and smaller.

5.6.9 Pressure-gage piping.

5.6.10 Soot-blower valve units and soot-blower flanges.

5.6.11 Piping in voids and cofferdams except where omitting insulation may be detrimental to system operation, such as catapult steam.

5.6.12 Safety valve bodies, springs, and lifting gear.

5.6.13 Piping over shower stalls, behind, and under lavatories.

5.6.14 Valves or flanges in the collection holding tank (CHT) System.

5.7 Higher temperature-type insulations may be used where lower temperature-type insulations are specified, provided that they are satisfactory in all other respects.

5.8 In “high traffic” locations where the completed insulation and lagging is liable to abuse, such as shipping, unshipping, and maintenance areas, protective sheet metal lagging should be installed. Where metal lagging is required, any of the materials listed in Table 13 are acceptable, except for boiler uptake applications in which metal lagging shall be galvanized sheet steel, in accordance with Specification A 526/A 526M, with coating designation G-115, and not less than 1/32 in. (0.8 mm) thick.

5.9 Before installing insulation, surface preparation of the piping is to be accomplished in accordance with the ship’s painting schedule.

5.10 Lacing hooks should be welded to the structure or equipment (with permission of the vendor of the equipment) for securing insulation to the equipment.

5.11 For bends, fittings, and so forth, in which molded sections of pipe insulation cannot be used, mitered sections of the pipe insulation or premolded fittings and covers may be used, provided that they are suitable for the temperature and that the requirements of this practice are satisfied (see 4.1 and 5.4). Fittings in sizes under 2-in. nominal pipe size (NPS) may

⁷ Available from U.S. Government Printing Office.

⁸ Available from U.S. Coast Guard (G-CMC/82), Washington, DC 20590.

TABLE 1 Insulation and Lagging Materials for Pipe, Tubing, and Fittings Used for Interior Piping Systems^{A,B}

Temperature Range °F (°C)	Insulation	Specification	Lagging ^C	Specification
-20 to +40 (-29 to +4)	cellular glass	C 552, Type II	fibrous glass cloth	MIL-C-20079, Type I, Classes 3 through 9
			sheet steel galvanized	commercial
	polyimide foam ^D	DOD-I-24688, Type I, with vapor retarder	fibrous glass cloth	MIL-C-20079, Type I, Classes 3 through 9
41 to 125 (5 to 51)	elastomeric foam plastic ^A	MIL-P-15280, Form T	fibrous glass cloth	MIL-C-20079, Type I, Classes 3 through 9
	cellular glass	C 552, Type II	fibrous glass cloth	MIL-C-20079, Type I, Classes 3 through 9
			sheet steel galvanized	commercial
	polyimide foam	DOD-I-24688, Type I, with vapor retarder	fibrous glass cloth	MIL-C-20079, Type I, Classes 3 through 9
	elastomeric foam plastic ^A	MIL-P-15280, Form T	fibrous glass cloth	MIL-C-20079, Type I, Classes 3 through 9
	126 to 450 (52 to 232)	cellular glass	C 552, Type II	fibrous glass cloth
sheet steel galvanized				commercial
polyimide foam ^E		DOD-I-24688, Type I	fibrous glass cloth	MIL-C-20079, Type I, Classes 3 through 9
451 to 1050 (233 to 566)	elastomeric foam plastic ^A 180°F (82°C) max	MIL-P-15280, Form T	fibrous glass cloth	MIL-C-20079, Type I, Classes 3 through 9
	cellular glass 800°F (427°C) max	C 552, Type II	fibrous glass cloth	MIL-C-20079, Type I, Classes 3 through 9
			sheet steel galvanized	commercial
	calcium silicate	C 533	fibrous glass cloth	MIL-C-20079, Type I, Classes 3 through 9
	expanded perlite	C 610	fibrous glass cloth	MIL-C-20079, Type I, Classes 3 through 9
			sheet steel galvanized	commercial
sheet steel black			commercial	
mineral fiber	C 547, Class 2 (850°F max) or Class 3	sheet steel black	commercial	
calcium silicate	C 533	sheet steel black	commercial	
expanded perlite	C 610	sheet steel black	commercial	

^A See 5.4.

^B Insulation and lagging materials are acceptable for the temperature ranges indicated; other materials may be used provided the requirements of this practice are satisfied. Thermal insulating tape may be used as allowed by Section 8 of this practice.

^C Lagging is to be used over insulation only.

^D See Navy Annex A1.5.

^E See Navy Annex A1.5.

be insulated with insulating cement, in accordance with Specification C 449/C 449M.

5.12 Where insulation specifications listed in Tables 1 and 3 provide for the use of nonmetal“ jacketed”-type insulation, separate lagging material may be omitted.

5.13 Single layered insulation construction shall be permitted on all surfaces operating at temperatures below 600°F (316°C). Double layered insulation construction shall be used with all joints staggered on all surfaces operating at temperatures of 600°F (316°C) and above, except single layered

TABLE 2 Insulation and Lagging Materials for Pipe, Tubing, and Fittings Used for Weather Exposed Piping Systems^A

Temperature Range ° F (°C)	Insulation	Specification	Lagging	Specification
-20 to +40 (-29 to +4)	cellular glass	C 552, Type II	fibrous glass cloth	MIL-C-20079, Type I Class 7 (fittings) Class 9 (piping)
	polyimide foam	DOD-I-24688, Type I, with vapor retarder	fibrous glass cloth	MIL-C-20079, Type I Class 7 (fittings) Class 9 (piping)
	perlite	C 610	fibrous glass cloth	MIL-C-20079, Type I Class 7 (fittings) Class 9 (piping)
41 to 100 (5 to 37)	cellular glass	C 552, Type II	corrosion resistant steel	A 167, Type 304
	polyimide foam	DOD-I-24688, Type I, with vapor retarder	fibrous glass cloth	MIL-C-20079, Type I Class 7 (fittings) Class 9 (piping)
	perlite	C 610	corrosion resistant steel	A 167, Type 304
	calcium silicate	C 533	corrosion resistant steel	A 167, Type 304
	mineral fiber ^B	C 547, Class 2 or 3	corrosion resistant steel	A 167, Type 304
101 to 450 (38 to 232)	cellular glass	C 552, Type II	corrosion resistant steel	A 167, Type 304
	polyimide foam ^C	DOD-I-24688, Type I	corrosion resistant steel	A 167, Type 304
	perlite	C 610	corrosion resistant steel	A 167, Type 304
	calcium silicate	C 533	corrosion resistant steel	A 167, Type 304
	mineral fiber ^B	C 547, Class 2 or 3	corrosion resistant steel	A 167, Type 304

^A Insulation and lagging materials listed are acceptable for the temperature ranges indicated; other materials may be used provided the requirements of this standard are satisfied.

^BSee Navy Annex A1.5.

^CSee Navy Annex A1.15.

construction will be permitted when the total insulation thickness is 3 in. (76 mm) or less or the pipe size is NPS 2 in. (52 mm) or below.

6. Selection Requirements, Piping

6.1 *Interior Piping, Temperature Range -20 to +40°F (-29 to +4°C)*—Use for air conditioning and vessel's stores refrigerant piping and other services within the temperature range.

6.1.1 For insulation and lagging materials, see Table 1.

6.1.2 For insulation thickness, see Table 4 or Table 5.

6.1.3 For installation details, see Fig. 1, Fig. 2, or Fig. 3 as applicable.

6.2 *Interior Piping, Temperature Range 41 to 125°F (5 to 52°C)*—Use for cold fresh water, plumbing drains, firemain, main and auxiliary, salt water circulating, and salt water cooling, piping, and other services within the temperature range.

6.2.1 For insulation and lagging materials, see Table 1.

6.2.2 For insulation thickness, see Table 4, Table 5, or Table 7.

6.2.3 For installation details, see Fig. 1, Fig. 2, Fig. 3, or Fig. 4 as applicable.

6.2.4 *Special Conditions:*

6.2.4.1 Piping systems operating in this temperature range including water closet drain piping do not require insulation except where damage or discomfort may result from condensation.

6.2.4.2 Dry firemain need only be insulated above ceilings and in areas where damage or discomfort may be realized from condensation.

6.2.4.3 If cold fresh or potable water tanks (not having a side integral with the shell) are installed in a heated area, the piping to the pumps and therefore to the services need not be insulated. If this water is being used for flushing water closets, the drain piping need not be insulated.

6.2.4.4 Fresh water fill piping inside the vessel shall be insulated.

6.2.4.5 Drains from drinking water chillers shall be insulated.

6.3 *Interior Piping, Temperature Range 126 to 450°F (52 to 232°C)*—Use for hot fresh water, hot water heating, fuel oil service discharge from heaters to headers, condensate, and air ejector piping, boiler feed, high and low pressure steam drain piping, and other services within the temperature range.

6.3.1 For insulation and lagging materials, see Table 1.

6.3.2 For insulation thickness, see Table 4, Table 5, Table 7, Table 8, or Table 9.

6.3.3 For installation details, see Fig. 1, Fig. 2, Fig. 3, Fig. 4, Fig. 5, or Fig. 6 as applicable.

6.3.4 *Special Conditions*—On piping, tubing, and fittings sized less than NPS 3/8 in., insulation need be applied only where required for personnel protection.

6.4 *Interior Piping, Temperature Range 451 to 1200°F (233*

TABLE 3 Insulation and Lagging Materials for Machinery and Equipment^{A,B}

Temperature Range °F (°C)	Insulation	Specification	Lagging	Specification
-20 to +40 (-29 to +4)	elastomeric foam plastic ^A	MIL-P-15280, Form S	fibrous glass cloth	MIL-C-20079, Type I, Classes 3 through 9
	polyimide foam	DOD-I-24688, Type I	fibrous glass cloth with vapor retarder	MIL-C-20079 Type I, Classes 3 through 9
	cellular glass	C 552, Type II	sheet steel galvanized	commercial ^C
41 to 125 (5 to 51)	elastomeric foam plastic ^A	MIL-P-15280, Form S	fibrous glass cloth	MIL-C-20079, Type I, Classes 3 through 9
	polyimide foam	DOD-I-24688, Type I	fibrous glass cloth with vapor retarder	MIL-C-20079, Type I, Classes 3 through 9
	cellular glass	C 552, Type I	fibrous glass cloth, or sheet steel black commercial	MIL-C-20079, Type I, Classes 3 through 9
	mineral fiber blanket	C 553	sheet steel black, commercial or fibrous glass cloth with vapor retarder	MIL-C-20079, Type I, Classes 3 through 9
126 to 1200 (52 to 649)	fibrous glass felt	MIL-I-16411, Type II	fibrous glass cloth	MIL-C-20079, Type I, Classes 7 or 9
			glass wire, reinforced	HHP-31, Type I
	polyimide foam ^D (450° max)	DOD-I-24688, Type I	fibrous glass cloth	MIL-C-20079, Type I, Classes 3 through 8
	refractory fiber blanket	C 892, Grade 6 or 8	sheet steel black commercial or fibrous glass cloth	MIL-C-20079, Type I, Classes 3 through 9
			glass wire, reinforced	HHP-31, Type I
	elastomeric foam plastic (180°F max)	MIL-P-15280 sheet	fibrous glass cloth	MIL-C-20079, Type I, Classes 3 through 9
	high-temperature insulating cement ^E	C 195		
	calcium silicate thermal insulating block	C 533		
	mineral fiber blanket (1000°F max)	C 553, C 612	sheet steel black, or commercial fibrous glass cloth	MIL-C-20079, Type I, Classes 3 through 9
			glass wire, reinforced	HHP-31, Type I
	perlite	C 610	fibrous glass cloth	MIL-C-20079, Type I, Classes 3 through 9

^A See 5.4.

^B Insulation and lagging materials listed are suitable for use in the temperature ranges indicated; other materials may be used provided the requirements of this standard are satisfied.

^C With or without rewettable adhesive.

^D See Navy Annex A1.15.

^E When insulating cement is used, it shall be applied in successive layers, ½ to 1 in. in thickness, until the total thickness specified in Table 7 has been reached. Galvanized iron wire netting, 1-in. mesh, shall be installed between layers. A ½-in. thickness of finishing cement, in accordance with Specification C 449, shall be applied over the last layer of insulating cement.

to 649°C)—Use for main steam, auxiliary steam, exhaust and bleed steam, gland seal steam and exhaust, high and low-pressure steam drains, soot blower steam, boiler blow, safety and relief valve escape steam heating, diesel exhaust piping, and other services within the temperature range.

6.4.1 For insulation and lagging materials, see Table 1.

6.4.2 For insulation thickness, see Table 4, Table 7, Table 8, or Table 9, as applicable.

6.4.3 For installation details, see Fig. 1, Fig. 4, Fig. 5, or Fig. 6, as applicable.

6.4.4 Special Conditions:

6.4.4.1 The soot blower piping between the root valve and the soot blower heads shall have an insulation thickness of one half of that indicated for a continually operating system at the same temperature.

6.4.4.2 Main steam piping insulation shall be arranged with removable pads to bare sections for audiogauging when required.

6.4.4.3 Turbogenerator exhaust to main and auxiliary condensers do not require insulation except in areas where

TABLE 4 Thickness of Cellular Glass Insulation for Piping, -20° to 800°F (-29° to 427°C)^A

Nominal Pipe Size, in.	Maximum Temperature, °F × Thickness, in.								
	-20 to 40 ^B	41 to 125 ^C	250	350	450	550	650	750	850
¼ and above	2½ 1½ ^D	1 ½ ^D
1½ and below	1	1	1½	2	2½	2½	3
2	1	2	1½	2	3	3	3½
2½, 3	1	1½	2	2½	3	3½	4
4	1	1½	2	2½	3½	3½	4
5, 6	1	1½	2	3	3½	3½	4½
8	1½	1½	2	3	3½	4	5
10	1½	1½	2	3	4	4	5
12	1½	1½	2½	3	4	4½	5½
14	1½	1½	2½	3½	4	4½	5½
16	1½	1½	2½	3½	4½	4½	5½
18	1½	1½	2½	3½	4½	4½	5½

^A Thickness of cellular glass, in accordance with Specification C 552, Type II.
^B For refrigerant piping.
^C For antisweat applications.
^D Thickness for applications in air conditioned spaces only.

TABLE 5 Thickness of Elastomeric Foam Plastic Insulation Piping, -20° to 180°F (-29° to 82°C)^A

Nominal Size, in.	Temperature Range, °F	Nominal Thickness, in.	
¼ and above	-20 to 40 ^B	1½	1 ^C
	41 to 125 ^D	¾	½ ^C
	126 to 180	½	½ ^C

^A Thickness of elastomeric foam plastic insulation, conforming with MIL-P-15280, Form T.
^B For refrigerant piping.
^C Thickness for applications in air conditioned spaces only.
^D For antisweat applications.

TABLE 6 Thickness of Polyimide Foam Insulation Piping -20° to 450°F (-29° to 232°C)^A

Nominal Size, in.	Temperature Range, °F	Nominal Thickness, in.	
¼ and above	-20 to 40 ^B	1½	1 ^C
	41 to 125 ^D	¾	½ ^C
	126 to 180	½	
	181 to 250	¾	
	251 to 350	1	
	351 to 450	1½	

^A Thickness of polyimide foam insulation conforming with DOD-I-24688.
^B For refrigerant piping.
^C Thickness for applications in air conditioned spaces only.
^D For antisweat applications.

TABLE 7 Thickness of Mineral Fiber Insulation for Hot Piping, 850°F (454°C) Maximum^{A,B}

Nominal Pipe Size, in.	Maximum Temperature, °F × Thickness, in.							
	150	250	350	450	550	650	750	850
1½ and below	1	1	1	1½	2	2	2½	3
2	1	1	1	1½	2	2½	2½	3½
2½, 3	1	1	1	1½	2	3	3½	3½
4	1	1	1	1½	2	3	3½	4
5, 6	1	1	1	2	2½	3	3½	4
8	1	1	1	2	2½	3	3½	4½
10	1	1	1½	2	2½	3½	3½	4½
12	1	1	1½	2	2½	3½	4½	4½
14, 16, 18	1	1	1½	2	3	3½	4½	5

^A Commercially known as fibrous glass.
^B Thickness of mineral fiber insulation, in accordance with Specification C 547, Class 2.

susceptible to personnel contact.

6.4.4.4 Safety and relief valve escape piping need not be insulated except in areas where susceptible to contact by personnel.

6.4.4.5 Boiler blow piping need not be insulated except in areas where susceptible to contact by personnel.

6.4.4.6 On piping, tubing, and fittings sizes less than NPS ¾ in., insulation need be applied only where required for personnel protection.

6.4.4.7 Steam smothering and steam to the sea chests need be insulated only in those areas where susceptible to personnel contact.

6.5 *Weather-Exposed Piping, Temperature Range -20 to +40°F (-29 to +4°C)*—Use for low-temperature piping exposed to the weather.

6.5.1 For insulation and lagging materials, see Table 2.

6.5.2 For insulation thickness, see Table 4.

6.5.3 For installation details, see Fig. 3, Fig. 7, or Fig. 8.

6.5.4 *Special Conditions:*

6.5.4.1 Piping exposed to the weather should also be effectively insulated against freezing. The thickness of insulation required to prevent freezing is determined by calculation based on the system fluid, system velocity, type of insulation to be used, and climatic conditions involved. This does not apply to systems that are normally secured and drained.

6.5.4.2 At pipe supports, remove only enough insulation to provide a snug fit. Fill voids between insulation and support with tightly packed fibrous glass felt, conforming with MIL-I-16411, Type II, to within ¼ in. (6.3 mm) of the insulation surface. Fill the remainder with end-sealing compound, conforming with MIL-C-22395, overlapping both the support member and the adjacent insulation. Lag and coat with the same materials as the adjacent pipe.

6.6 *Weather-Exposed Piping, Temperature Range 41 to 450°F (5 to 232°C)*—Use for hot piping systems exposed to weather.

6.6.1 For insulation and lagging materials, see Table 2.

6.6.2 For insulation thickness, see Table 4, Table 7, Table 8, or Table 9.

6.6.3 For installation details, see Fig. 3, Fig. 7, or Fig. 8.

6.6.4 *Special Conditions:*

6.6.4.1 Piping exposed to the weather should be effectively insulated against freezing. The thickness of insulation required

TABLE 8 Thickness of Mineral Fiber Insulation for Hot Piping, 1050°F (566°C) Maximum^{A,B}

Nominal Pipe Size, in.	Maximum Temperature, °F × Thickness, in.									
	150	250	350	450	550	650	750	850	950	1050
1½ and below	1	1	1	1½	2	2	2	2½	3	3½
2	1	1	1	1½	2	2½	2½	3	3½	4
2½, 3	1	1	1	1½	2	2½	3½	3½	4	4½
4	1	1	1	1½	2	3½	3	3½	4	4½
5, 6	1	1	1½	2	2½	3	3	3½	4½	5½
8	1	1	1½	2	2½	3	3	4	4½	5½
10	1	1	1½	2	2½	3	3½	4	5	6
12	1	1	1½	2	2½	3½	3½	4	5	6
14	1	1	1½	2	2½	3½	3½	4½	5½	6½
16	1	1	1½	2	3	3½	3½	4½	5½	6½
18	1	1	1½	2	3	3½	4	4½	5½	6½

^A Commercially known as mineral wool.

^B Thickness of mineral fiber insulation, in accordance with Specification C 547, Class 3.

TABLE 9 Thickness of Calcium Silicate Insulation (Specification C 533) for Hot Piping, 1050°F (566°C) Maximum^A

Nominal Pipe Size, in.	Maximum Temperature, °F × Thickness, in.									
	150	250	350	450	550	650	750	850	950	1050
1½ and below	1	1	1	1½	2	2½	2½	2½	3	3½
2	1	1	1	1½	2	2½	2½	3	3½	4
2½, 3, 4	1	1	1½	2	2½	3	3	3½	4	5
5, 6	½	½	1½	2	2½	3½	3½	4	4½	5½
8	½	½	1½	2	2½	3½	3½	4	5	5½
10	½	½	1½	2	3	3½	3½	4½	5	6
12	½	½	1½	2	3	3½	3½	4½	5½	6
14	½	½	1½	2½	3	4	4	4½	5½	6½
16, 18	½	½	1½	2½	3	4	4	5	5½	6½

^A Thickness of calcium silicate insulation, in accordance with Specification C 533.

TABLE 10 Thickness of Perlite Insulation (Specification C 610) for Hot Piping, 1050°F (566°C) Maximum^A

Nominal Pipe Size, in.	Maximum Temperature, °F × Thickness, in.									
	150	250	350	450	550	650	750	850	950	1050
1½ and below	1	1	1	1½	2	2½	2½	2½	3	3½
2	1	1	1	1½	2	2½	2½	3	3½	4
2½, 3, 4	1	1	1½	2	2½	3	3	3½	4	5
5, 6	1½	1½	1½	2	2½	3½	3½	4	4½	5½
8	1½	1½	1½	2	2½	3½	3½	4	5	5½
10	1½	1½	1½	2	3	3½	3½	4½	5	6
12	1½	1½	1½	2	3	3½	3½	4½	5½	6
14	1½	1½	1½	2½	3	4	4	4½	5½	6½
16, 18	1½	1½	1½	2½	3	4	4	5	5½	6½

^A Thickness of perlite insulation, in accordance with Specification C 610.

to prevent freezing is determined by calculation based on the system fluid, system velocity, type of insulation to be used, and climatic conditions involved. This does not apply to systems that are normally secured and drained.

6.6.4.2 At pipe supports, remove only enough insulation to provide a snug fit. Fill voids between the insulation and support with tightly packed fibrous glass felt, conforming with MIL-I-16411, Type II, to within ¼ in. (6.4 mm) of the insulation surface. Fill the remainder with end-sealing compound, conforming with MIL-C-22395, overlapping both the support member and the adjacent insulation. Lag and coat with the same materials as the adjacent pipe.

7. Selection Requirements, Machinery and Equipment

7.1 *Temperature Range -20 to +40°F (-29 to +4°C)*—Use for refrigerant and other equipment within the temperature range.

7.1.1 For insulation and lagging materials, see Table 3.

7.1.2 For insulation thickness, see Table 11.

TABLE 11 Thickness of Antisweat Insulation for Machinery and Equipment

Temperature Range, °F (°C)	Material Specification	Nominal Thickness, in. ^A
-20 to +40 (-29 to +4)	elastomeric foam plastic, MIL-P-15280, Form S	2 1 ^B
	polyimide foam, DOD-I-24688, Type I with vapor retarder	2 1 ^B
41 to 125 (5 to 51)	cellular glass, C 552 Type 1	3 1½ ^B
	elastomeric foam plastic, MIL-P-15280, Form S	¾ ½ ^B
	polyimide foam, DOD-I-24688, Type I with vapor retarder	1 ¾ ^B
	cellular glass, C 552, Type 1	1 ½ ^B
	mineral fiber blanket, C 553, C 612	1 ¾ ^B

^A Nominal thickness exclusive of vapor retarder.

^B Thickness for application in air-conditioned spaces only.

7.1.3 For installation details, see Fig. 9, Fig. 10, or Fig. 11 as applicable.

7.2 *Temperature Range 41 to 125°F (5 to 52°C)*—Use for

TABLE 12 Thickness of Insulating Materials for Hot Surfaces of Machinery and Equipment, 126 to 1200°F (52 to 649°C)

Material	Maximum Temperature, °F × Thickness, in. ^A									
	150	250	350	450	550	650	750	850	950	1050
Fibrous glass felt, MIL-I-16411, Type II	1	1	1½	2½	3	4	4	5	5½	6½
Block calcium silicate, C 533	1½	1½	2	2½	4	4	4	5	5	5½
Block perlite, C 610	1½	1½	2	2½	4	4	4	5	5	5½
Refractory fiber, C 892, Grade 6	1	1	2	2½	3½	4½	4½	5½	6	7½
Refractory fiber, C 892 Grade 8	1	1	1½	2½	3	4	4	5	6	7
Mineral fiber, ^B C 553, C 612	1½	1½	2	2½	3½	3½	3½	4	4½	5 ^B
Elastomeric foam, ^C MIL-P-15280, Form S	½	½ ^C								
Polyimide foam, DOD-I-24688 ^D	¾	1	+1½	+2						
Insulating cement, ^E C 195	2	2	2½	3½	5	5	5	5½		

^A Does not include finishing cement.

^B 1000°F (537°C) maximum temperature.

^C 180°F (82°C) maximum temperature.

^D See Navy Annex A1.15.

^E Not to be used alone above 850°F.

TABLE 13 Metal Lagging Materials^A

Material	Specification	Nominal Thickness
Hot dipped galvanized steel	A 526/A 526M Coating designation G-115	0.014
Aluminum	B 209, 6061	0.030
Corrosion resistant steel	A 167, Type 304	0.014

^A For use on piping and machinery insulation in locations where insulation is subject to abuse, except for uptake applications where metal lagging shall be galvanized steel, Specification A 526/A 526M, coating designation G-115, not less than ½ in. thick.

low-temperature machinery and equipment within the temperature range.

7.2.1 For insulation and lagging materials, see Table 3.

7.2.2 For insulation thickness, see Table 11.

7.2.3 For installation details, see Fig. 9, Fig. 10, Fig. 11, or Fig. 12 as applicable.

7.2.4 *Special Conditions*—Machinery or equipment operating in this temperature range does not require insulation except where damage or discomfort may result from condensation.

7.3 *Temperature Range 126 to 1200°F (52 to 649°C)*—Use for medium and high-temperature machinery and equipment within the temperature range.

7.3.1 For insulation and lagging materials, see Table 3.

7.3.2 For insulation thickness, see Table 12.

7.3.3 For installation details, see Fig. 10, Fig. 11, Fig. 12, Fig. 13, or Fig. 14 as applicable.

8. Insulation and Lagging Requirements for Removable Covers for Valves, Fittings, Flanges, and Machinery or Equipment

8.1 *Removable Covers*—Flanged valves and fittings and pipeline flanges shall have removable covers to permit servicing of take-down joints.

8.1.1 Removable covers shall be manufactured using materials specified in 8.2 through 8.4 and to thicknesses specified in Tables 4-7. Stitching, lacing, and quilting (required to prevent sagging) shall be accomplished with materials specified in 8.5 and as shown in Figs. 15-17.

8.1.2 Removable covers may also be manufactured from segments of block insulation or from preformed sectional pipe covering and molded (premolded) components. When a re-

movable cover is made of segments of block insulation or preformed (premolded) sectional pipe covering, it shall be of the same material and thickness as the adjoining pipe insulation.

8.2 Filler Materials for Removable Blankets:

8.2.1 Fibrous glass felt, conforming with MIL-I-16411, Type II.

8.2.2 Refractory fiber blanket, in accordance with Specification C 892, Grade 8.

8.2.3 Refractory fiber blanket, also in accordance with Specification C 892, Grade 6.

8.2.4 Mineral fiber blanket, in accordance with Specification C 612, Class 4.

8.3 Covering or Encapsulating Materials for Removable Blankets:

8.3.1 For surface temperatures 450°F and below, the filler shall be encapsulated with fiberglass cloth, conforming with MIL-C-20079, Type I, Class 9 (see Fig. 18, Detail A).

8.3.2 For surface temperatures above 450°F, the entire outside surface shall be encapsulated with TY304 stainless steel wire mesh, 0.011-in. diameter, No. 60 density, and crimped (see Fig. 18, Detail B). Alternatively, the entire outside surface may be encapsulated with fiberglass cloth, inserted with stainless steel reinforcement, in accordance with HH-P-31, Type I, Class 1.

8.3.3 The cold or top side of the surface shall be covered with fiberglass cloth, conforming with MIL-C-20079, Type I, Class 9. The bottom and side surface areas shall be covered as follows:

8.3.3.1 Fiberglass cloth, shall be inserted with stainless steel wire reinforcement, conforming with HH-P-31, Type I, Class 1 (see Fig. 18, Detail C); or

8.3.3.2 Fiberglass cloth, conforming with MIL-C-20079, Type I, Class 9, with TY304 stainless steel wire mesh, 0.008-in. diameter and No. 60 density, shall be crimped sewn onto the fibrous cloth (see Fig. 18, Detail D); or

8.3.3.3 TY304 stainless steel wire mesh, 0.011-in. diameter and No. 60 density, shall be crimped (see Fig. 18, Detail E).

8.4 *Alternative Covering Materials* (for surface temperatures 450°F and below, and for cold or top-side covering for

TABLE 14 Thickness of Fiberglass Felt for Removable Insulation Blankets^A

Nominal Pipe Size, in.	Maximum Temperature, °F × Thickness, in.									
	150	250	350	450	550	650	750	850	950	1050
1/2	1	1	1 1/2	1 1/2	2	2	2 1/2	2 1/2	3	3 1/2
1	1	1	1	1 1/2	2	2	2 1/2	3	3	3 1/2
1 1/2	1	1	1	1 1/2	2	2 1/2	2 1/2	3	3 1/2	4
2	1	1	1	1 1/2	2	2 1/2	2 1/2	3	3 1/2	4
3	1	1	1	1 1/2	2	2 1/2	3	3 1/2	4	4 1/2
4	1	1	1 1/2	2	2 1/2	3	3	3 1/2	4	5
6	1	1	1 1/2	2	2 1/2	3	3	4	4 1/2	5 1/2
8	1	1	1 1/2	2	2 1/2	3	3 1/2	4	5	5 1/2
10	1	1	1 1/2	2	2 1/2	3 1/2	3 1/2	4	5	6
12	1	1	1 1/2	2	2 1/2	3 1/2	3 1/2	4 1/2	5	6
14	1	1	1 1/2	2	2 1/2	3 1/2	3 1/2	4 1/2	5 1/2	6
16	1	1	1 1/2	2	3	3 1/2	3 1/2	4 1/2	5 1/2	6 1/2
18	1	1	1 1/2	2	3	3 1/2	4	4 1/2	5 1/2	6 1/2

^A Thickness of fiberglass felt, in accordance with MIL-I-16411, Type II.

TABLE 15 Thickness of 8-lb/ft³ Refractory Fiber Blanket for Removable Insulation Blankets^A

Nominal Pipe Size, in.	Maximum Temperature, °F × Thickness, in.									
	150	250	350	450	550	650	750	850	950	1050
1/2	1	1	1	1 1/2	1 1/2	2	2	2 1/2	3	3
1	1	1	1	1 1/2	2	2	2 1/2	3	3	3 1/2
1 1/2	1	1	1	1 1/2	2	2 1/2	2 1/2	3	3 1/2	4
2	1	1	1	1 1/2	2	2 1/2	2 1/2	3	3 1/2	4
3	1	1	1 1/2	2	2 1/2	3	3	3 1/2	4	4 1/2
4	1	1	1 1/2	2	2 1/2	3	3	3 1/2	4	4 1/2
6	1	1	1 1/2	2	2 1/2	3	3	4	4 1/2	5
8	1	1	1 1/2	2	2 1/2	3 1/2	3 1/2	4	4 1/2	5 1/2
10	1	1	1 1/2	2	3	3 1/2	3 1/2	4	5	5 1/2
12	1	1	1 1/2	2	3	3 1/2	3 1/2	4 1/2	5	6
14	1	1	1 1/2	2	3	3 1/2	3 1/2	4 1/2	5	6
16	1	1	1 1/2	2	3	3 1/2	3 1/2	4 1/2	5	6
18	1	1	1 1/2	2 1/2	3	3 1/2	4	4 1/2	5 1/2	6

^A Thickness of 8-lb/ft³ refractory fiber blanket, in accordance with Specification C 892, Grade 8.

TABLE 16 Thickness of 6-lb/ft³ Refractory Fiber Blanket for Removable Insulation Blankets^A

Nominal Pipe Size, in.	Maximum Temperature, °F × Thickness, in.									
	150	250	350	450	550	650	750	850	950	1050
1/2	1	1	1	1 1/2	1 1/2	2	2	2 1/2	2 1/2	3
1	1	1	1	1 1/2	2	2 1/2	2 1/2	2 1/2	3	3 1/2
1 1/2	1	1	1 1/2	1 1/2	2	2 1/2	2 1/2	2 1/2	3	4
2	1	1	1 1/2	1 1/2	2	2 1/2	2 1/2	3	3 1/2	4
3	1	1	1 1/2	2	2 1/2	3	3	3 1/2	4	4 1/2
4	1	1	1 1/2	2	2 1/2	3	3	3 1/2	4 1/2	5
6	1	1	1 1/2	2	2 1/2	3 1/2	3 1/2	4	4 1/2	5 1/2
8	1	1	1 1/2	2	2 1/2	3 1/2	3 1/2	4	5	5 1/2
10	1	1	1 1/2	2	3	3 1/2	3 1/2	4 1/2	5	6
12	1	1	1 1/2	2 1/2	3	3 1/2	4	4 1/2	5 1/2	6
14	1	1	2	2 1/2	3	4	4	4 1/2	5 1/2	6 1/2
16	1	1	2	2 1/2	3	4	4	4 1/2	5 1/2	6 1/2
18	1	1	2	2 1/2	3 1/2	4	4	5	6	6 1/2

^A Thickness of 6-lb/ft³ refractory fiber blanket, in accordance with Specification C 892, Grade 6.

temperatures above 450°F), are provided for removable blankets to be used in areas exposed to weather or where liquid penetration could present a fire hazard. Alternative coverings are as follows:

- 8.4.1 Silicone impregnated fiberglass cloth,
- 8.4.2 Silicone impregnated fiberglass cloth with aluminized facing on one side, and
- 8.4.3 Fiberglass cloth with aluminum or stainless steel facing laminated to one side.

8.5 *Hardware and Accessory Items for Removable Blanket Construction*—Necessary items shall include blanket lacing devices, blanket quilting devices, stitching materials, and installation materials.

8.5.1 *Blanket Lacing Devices:*

8.5.1.1 TY304 stainless steel lacing rings with lacing washers (see Fig. 19).

8.5.1.2 TY304 stainless steel lacing hooks with lacing washers (see Fig. 20).

8.5.1.3 TY303 stainless steel lacing capstan assembly sets (see Fig. 21).

8.5.1.4 TY304 stainless steel mechanical hook sets (see Fig. 22).

8.5.2 *Blanket Quilting Devices:*

8.5.2.1 TY304 stainless steel mechanical quilt sets (see Fig. 23).

TABLE 17 Thickness of Fiberglass Blanket for Removable Insulation Blankets^A

Nominal Pipe Size, in.	Maximum Temperature, °F × Thickness, in.							
	150	250	350	450	550	650	750	850
½	½	½	1	1	1½	2	2½	3
1	½	½	1	1½	2	2½	2½	3½
1½	½	½	1	1½	2	2½	3	3½
2	½	½	1	1½	2	2½	3	4
3	½	½	1	1½	2	3	3	4
4	½	½	1	1½	2½	3	3½	4½
6	½	½	1	2	2½	3½	3½	5
8	½	½	1	2	2½	3½	4	5
10	½	½	1½	2	2½	3½	4	5½
12	½	1	1½	2	2½	3½	4	5½
14	½	1	1½	2	3	4	4	5½
16	½	1	1½	2	3	4	4½	5½
18	½	1	1½	2	3	4	4½	6

^A Thickness of fiberglass blanket, in accordance with Specification C 612, Type II, C 553, Type IV.

8.5.2.2 TY304 stainless steel lacing washers with lacing wire (see Fig. 23).

8.5.3 Stitching Materials:

8.5.3.1 TY304 stainless steel hog rings.

8.5.3.2 TY304 stainless steel thread (0.011-in. diameter).

8.5.3.3 TY304 stainless steel staples.

8.5.3.4 Fiberglass thread (plain, polytetrafluoroethylene coated and wire inserted with monel or TY304 stainless steel, or both).

8.5.4 Installation Materials:

8.5.4.1 No. 18 gage copper lacing wire.

8.5.4.2 No. 18 gage soft or annealed TY304 stainless steel lacing wire.

8.5.4.3 No. 18 gage galvanized iron lacing wire.

8.5.4.4 TY304 stainless steel hog rings (particularly for installing thermal tape, refer also to Section 9).

8.6 Special Conditions:

8.6.1 Reuseable covers for machinery and equipment shall be fabricated from materials specified in Tables 14-17, in accordance with methods shown in Fig. 18 and configured to suit the specific application.

8.6.2 Unfired pressure vessels with butt welded inserts for which periodic radiographic inspection of the joint is required should have removable reuseable covers installed over the insert. These covers should extend 4 in. (102 mm) beyond the weld joint.

8.6.3 Removable covers shall not be used on systems insulated with elastomeric-foamed plastic insulation.

8.6.4 Services subject to frequent maintenance, such as reducing and regulating valves, shall be provided with easily removed and replaced tailored pads.

8.6.5 Removable blankets should not be used on cold systems (below ambient) or on systems where a vapor barrier is required.

8.6.6 When stitching two or more covering or encapsulating materials together, stainless steel staples, hog rings, 0.011-in. diameter stitching wire, or fiberglass thread (plain or wire inserted) may be used.

8.6.7 All construction details apply to removable blankets for flanges, valves, machinery and equipment, and other miscellaneous areas as determined by the specifier.

8.6.8 When installing removable blankets on valves, flanges, and various pieces of equipment, note that all void areas behind the insulation blanket are to be filled. The total required thickness of insulation shall not be achieved by including a loose wrap of fibrous glass felt or refractory fiber blanket as part of the required thickness.

9. Requirements for Thermal Insulating Tape

9.1 *Thermal Insulating Tape*—May be applied to pipe, sizes ¼ in. to ¾ in., for temperatures between 125 and 150°F (52 and 66°C) using materials specified in Section 8 and to thicknesses specified in Table 14. For manufacturing and installation details, see Fig. 6.

9.2 *Filler Materials for Thermal Insulating Tape*—See 8.2.

9.3 *Covering or Encapsulating Materials for Thermal Insulating Tape:*

9.3.1 For surface temperatures below 220°F, the entire outside surface shall be encapsulated with fiberglass cloth, conforming with MIL-C-20079, Type I, Class 3.

9.3.2 For surface temperatures 220° to 450°F, the entire outside surface shall be encapsulated with fiberglass cloth, conforming with MIL-C-20079, Type I, Class 9.

9.3.3 For surface temperatures above 450°F, the entire outside surface shall be encapsulated with fiberglass cloth, conforming with MIL-C-20079, Type I, Class 9, with an inner jacket of TY304 stainless steel wire mesh, 0.008-in. diameter, No. 60 density and crimped. Alternatively, the entire outside surface may be encapsulated with fiberglass cloth, inserted with stainless steel wire reinforcement, in accordance with HH-P-31, Type I, Class 1.

9.4 *Hardware and Accessory Items for Thermal Insulating Construction*—See 8.5.

9.5 *Special Conditions*—See 8.6.

10. Keywords

10.1 insulation; lagging; machinery insulation; marine; piping insulation; ship; shipboard insulation; thermal insulation; vessel

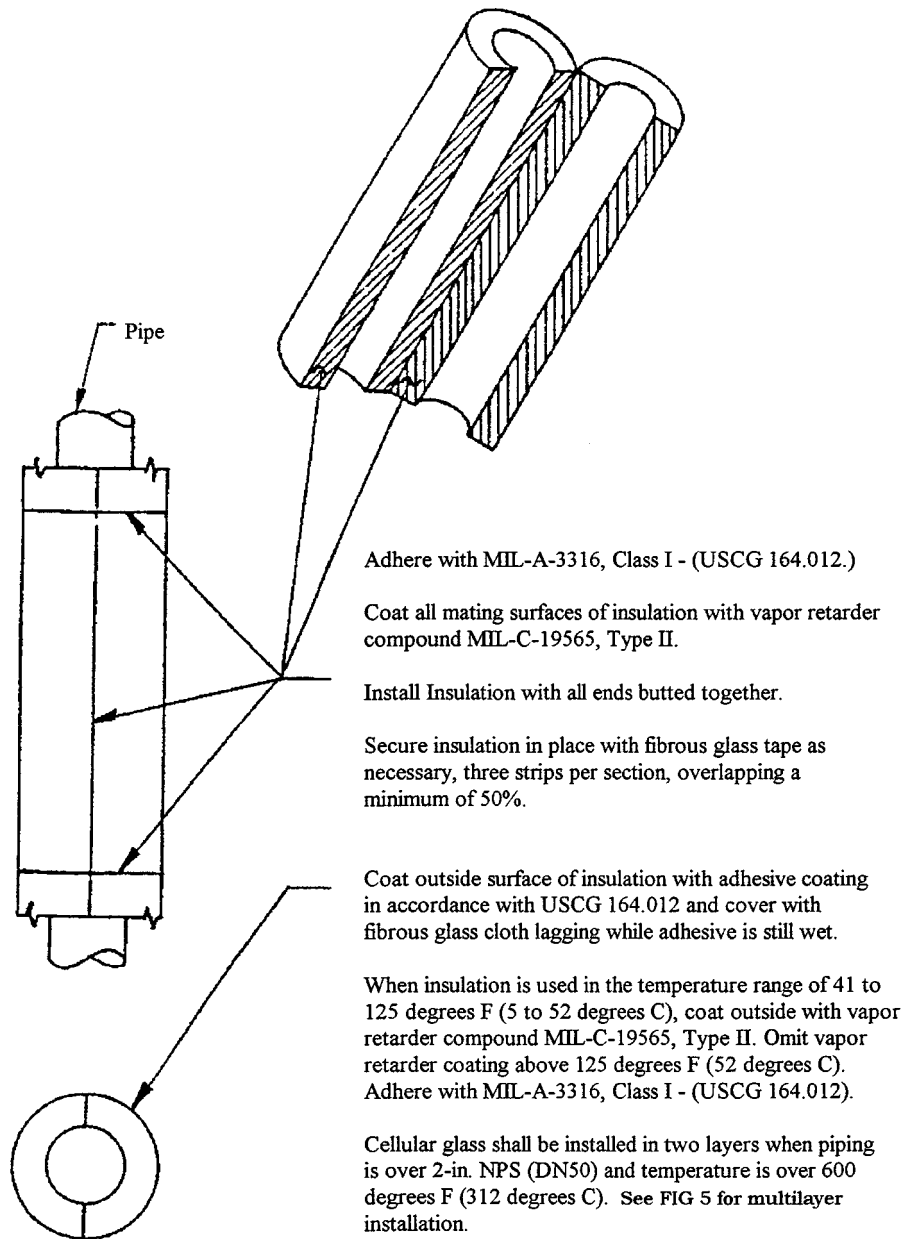
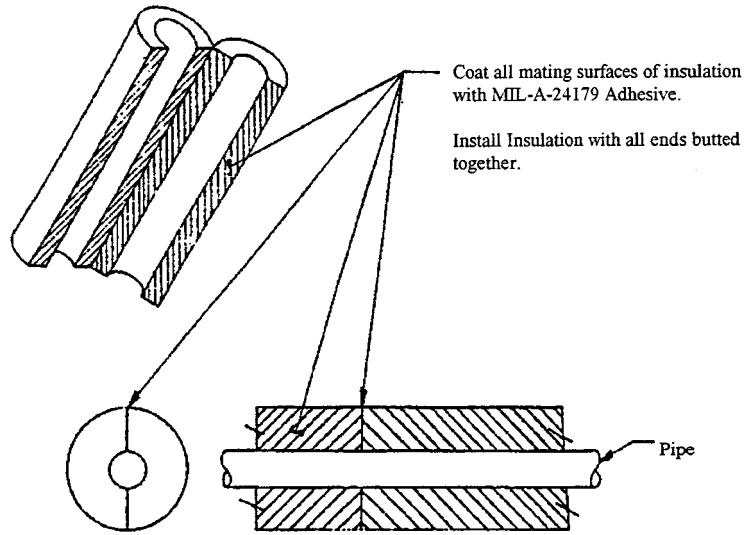
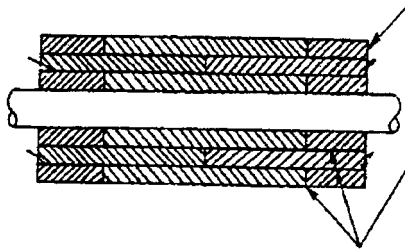

FIG. 1 Installation of Cellular Glass Pipe Insulation (Specification C 552)



Elastomeric Foamed Plastic Insulation MIL-P-15280 or EB 4013, may be applied in 1/4 in. (6mm) minimum thickness layers as necessary to build up the required thickness.



All end and horizontal joints shall be butted together and all joints staggered for multiple layer installation and secured with MIL-A-24179 Adhesive.

Application of a vapor retarder is not required on Elastomeric Foamed Plastic Insulation

Elastomeric Foamed Plastic Insulation should be coated with Adhesive MIL-A-3316, Class I, and covered with a glass cloth lagging per MIL-C-20079 or covered with re-wettable glass cloth per MIL-C-20079, only in areas where it is subject to damage.

FIG. 2 Installation of Elastomeric-Foamed Plastic Insulation (MIL-P-15280 or EB 4013)

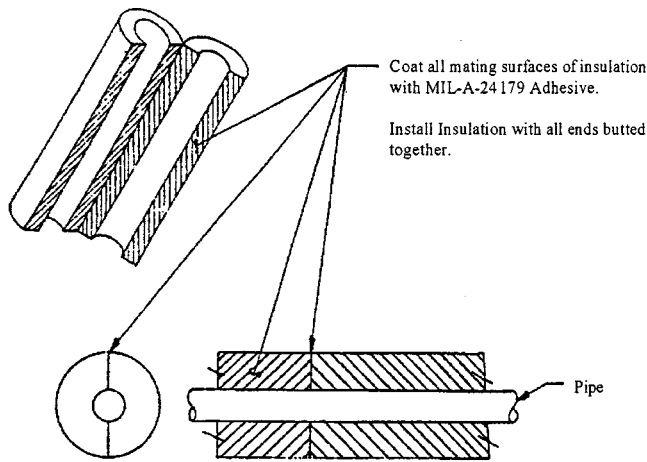

Polyimide Foam Insulation, DOD-I-24688, Type I, when used in the temperature range 100 to 370 degrees F (30 to 188 degrees C), shall be lagged with glass cloth with an adhesive conforming to the fire resistance requirements of MIL-A-3316. Fibrous glass cloth lagging shall be applied while the adhesive is still wet.

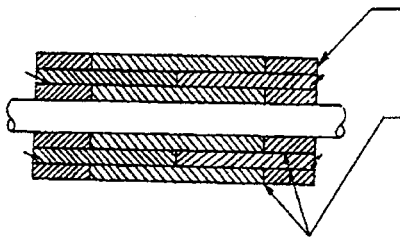

When insulation is used in the temperature range -20 to 100 degrees F (-29 to 38 degrees C), it shall be installed over clean, dry pipes, preferably with systems not operating and one of the following vapor retarder systems shall be used::

A) Aluminized polyester/aluminum foil with primer coated surface and reinforced with a fiberglass scrim shall be prelagged to the outer surface with adhesive that conforms to the fire resistance requirements of MIL-A-3316. Jacket lap shall be sealed with MIL-A-24179 adhesive or acrylic adhesive tape. All butt joints shall be sealed with 0.002 in (0.0525 mm) aluminum pressure sensitive tape.

B) Outside surface of insulation shall be lagged with glass cloth adhered with an adhesive conforming to the fire resistance requirements of MIL-A-3316 and painted over with MIL-C-19565, Type 2 vapor retarder paint. To ensure a continuous vapor retarder, the adhesive used to attach the glass cloth to the insulation must be dry before coating with MIL-C-19565.

FIG. 3 Installation of Polyimide Foam Insulation (DOD-I-24688)

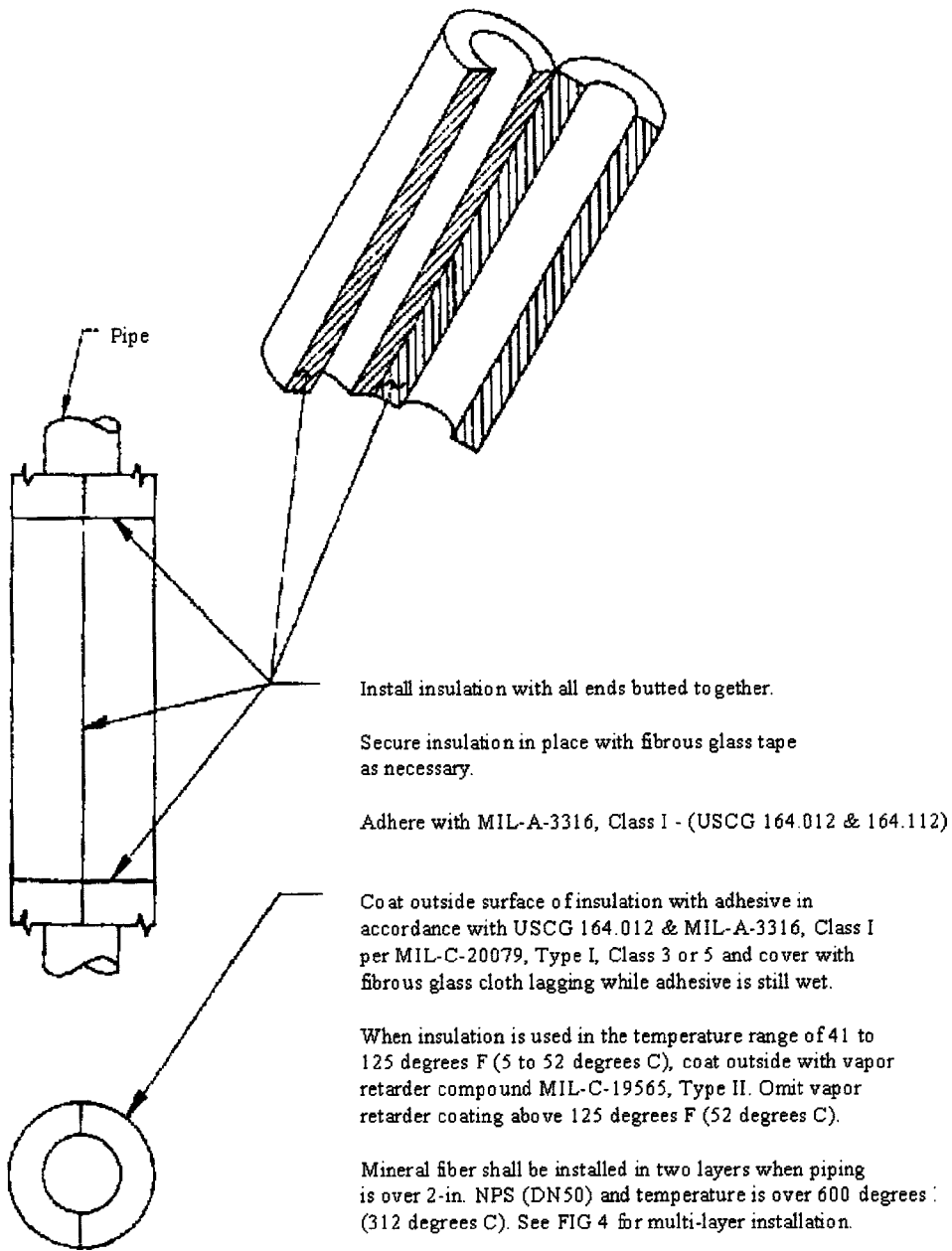
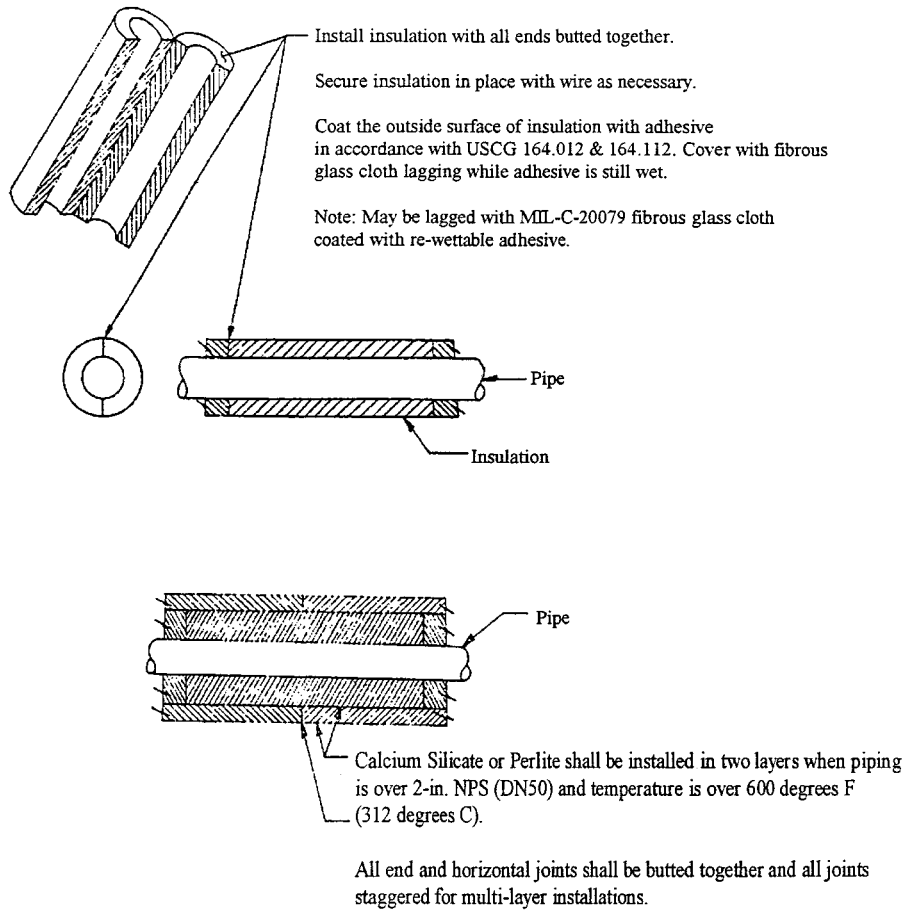
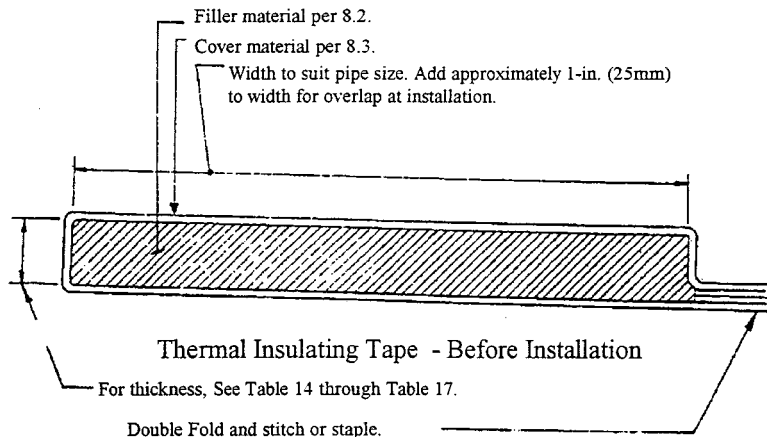

FIG. 4 Installation of Mineral Fiber Pipe Insulation (Specification C 547)



NOTE 1—For piping over 600°F (312°C), either single- or double-layer suitable expansion joints to permit thermal movement of the pipe without opening of the insulation should be provided.

FIG. 5 Installation of Calcium Silicate Pipe Insulation (Specification C 533) and Perlite Pipe Insulation (Specification C 610)



Double Fold and stitch or staple.

NOTE: For anti-sweat applications - double stitching is preferred and double coat stitching with vapor retarders. (See A1.10)

Prior to lacing, apply MIL-C-19565, Type II in joint before sewing.
For antisweat - Hand sew or hog ring at installation.

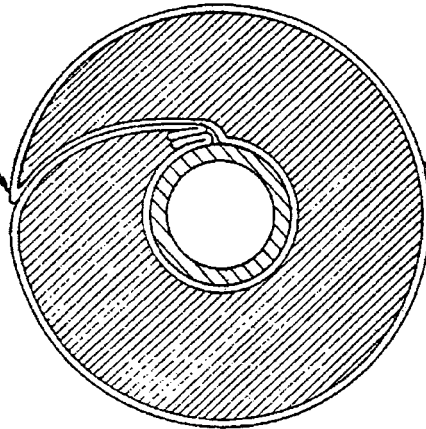

For anti-sweat applications, coat the outside surface with vapor retarder compound MIL-C-19565, Type II, after installation.

Thermal Insulating Tape After Installation

FIG. 6 Installation of Thermal Insulating Tape

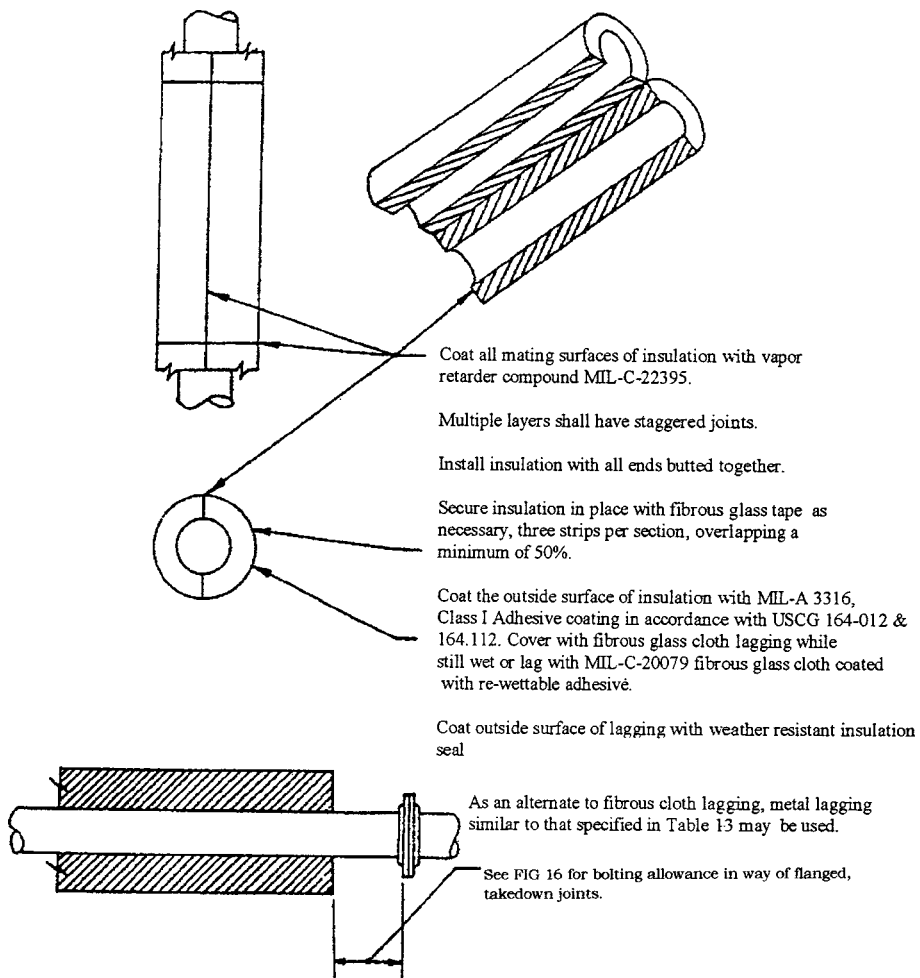

FIG. 7 Installation of Cellular Glass Pipe Insulation (Specification C 552) in the Weather

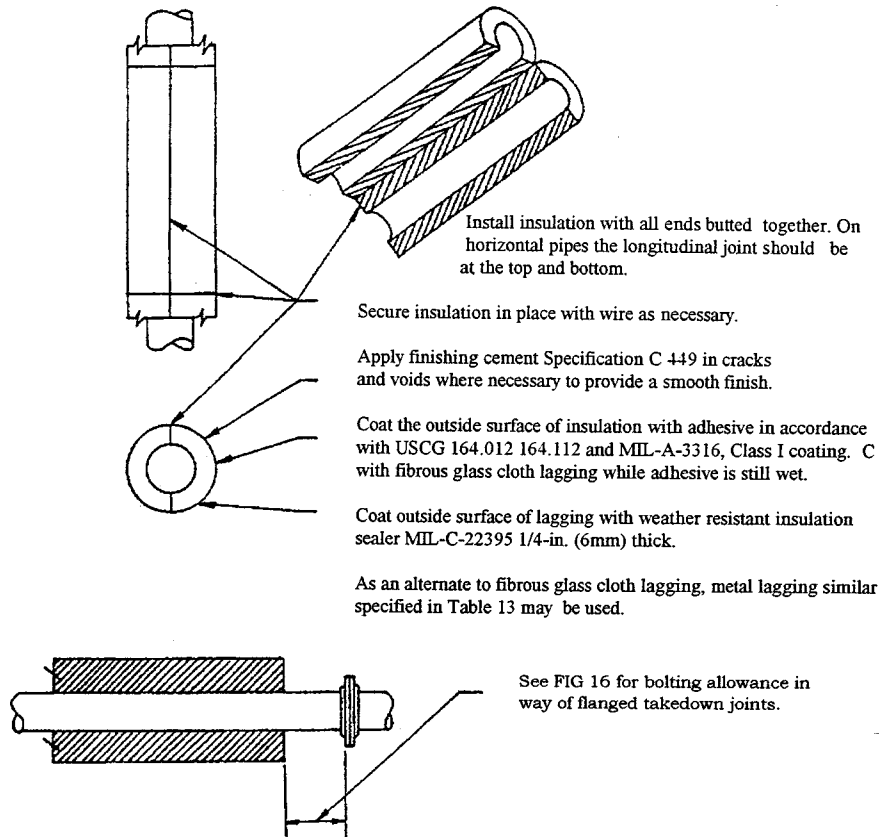

FIG. 8 Installation of Mineral Fiber Pipe Insulation (Specification C 547) or Calcium Silicate Pipe Insulation (Specification C 533) or Perlite Pipe Insulation (Specification C 610) in the Weather

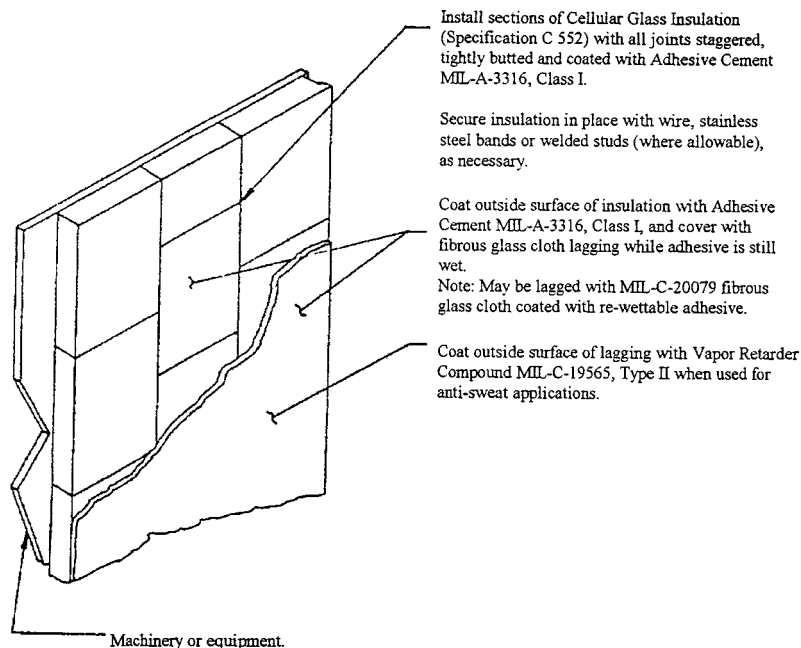

FIG. 9 Installation of Cellular (Foamed) Glass Insulation (Specification C 552) on Machinery and Equipment

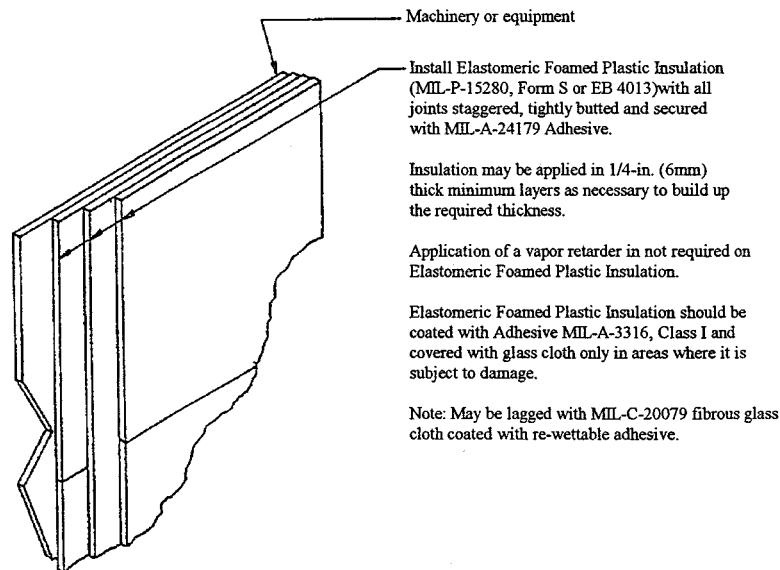

FIG. 10 Installation of Elastomeric Foamed Plastic Insulation (MIL-P-15280 or EB 4013) on Machinery or Equipment

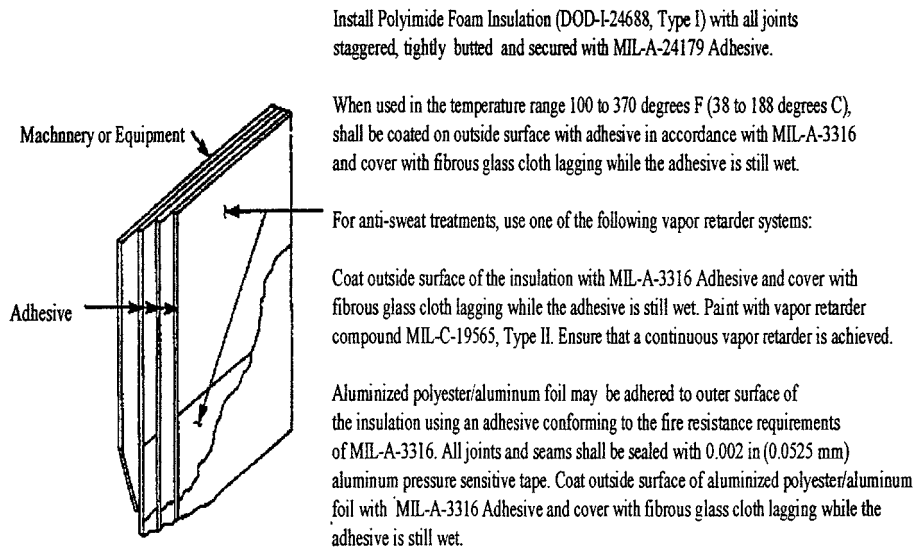

FIG. 11 Installation of Polyimide Foam Insulation (DoD-I-24688, Type I) on Machinery and Equipment

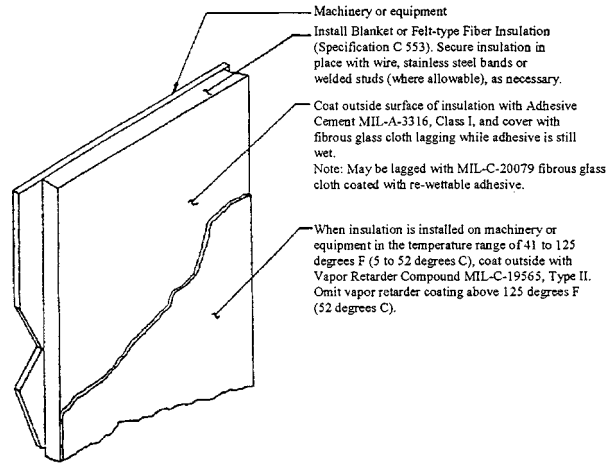

FIG. 12 Installation of Mineral Fiber Blanket or Felt Insulation (Specification C 553) on Machinery or Equipment (400°F max) (204°C)

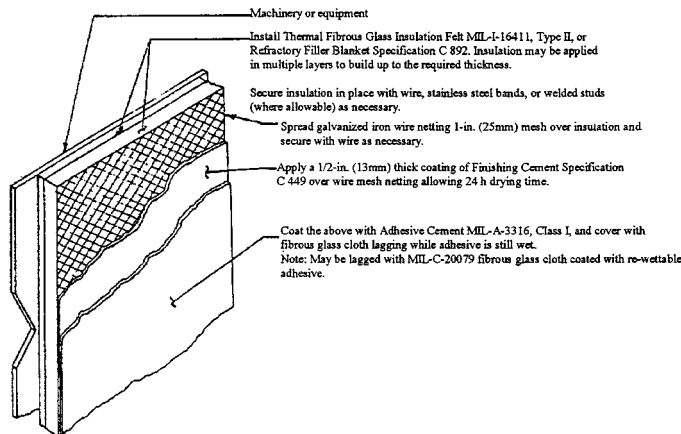

FIG. 13 Installation of Thermal Fibrous Glass Felt Insulation (MIL-I-16411) or Refractory Fiber Blanket Insulation (Specification C 892) on Machinery and Equipment (126 to 1200°F) (52 to 649°C)

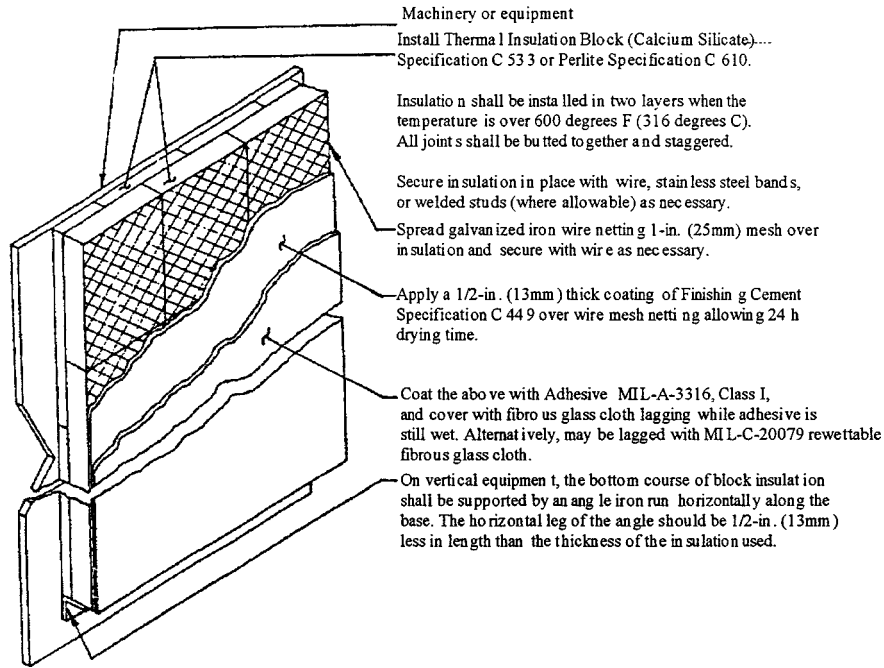

FIG. 14 Installation of Thermal Insulation Block (Calcium Silicate) (Specification C 533) or Perlite (Specification C 610) on Machinery and Equipment

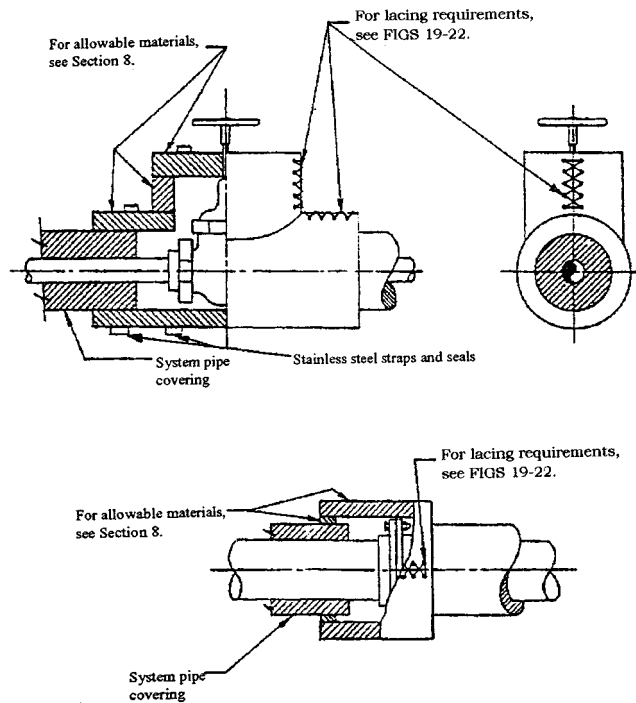

FIG. 15 Installation of Removable Covers for Valves, Fittings, and Flanges

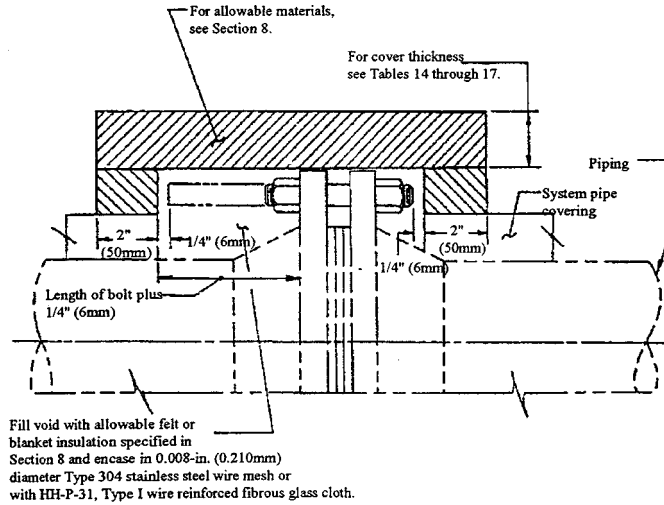

FIG. 16 Typical Removable Flange Cover Where Flange Diameter is Larger Than the Outside Diameter of the Adjacent Pipe Covering

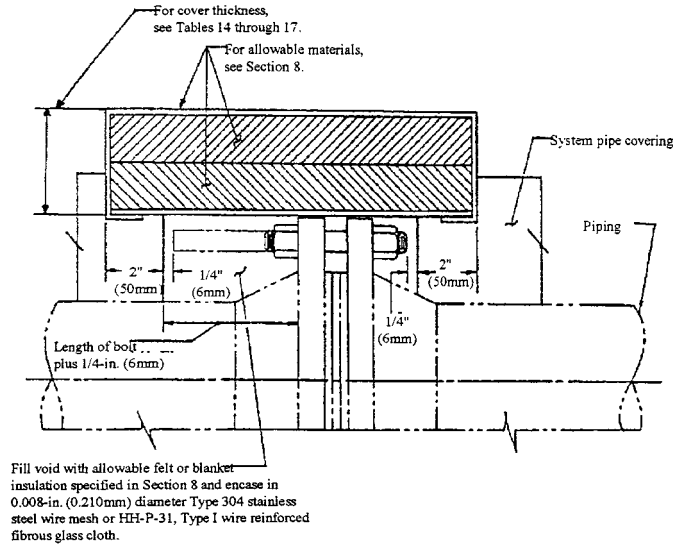
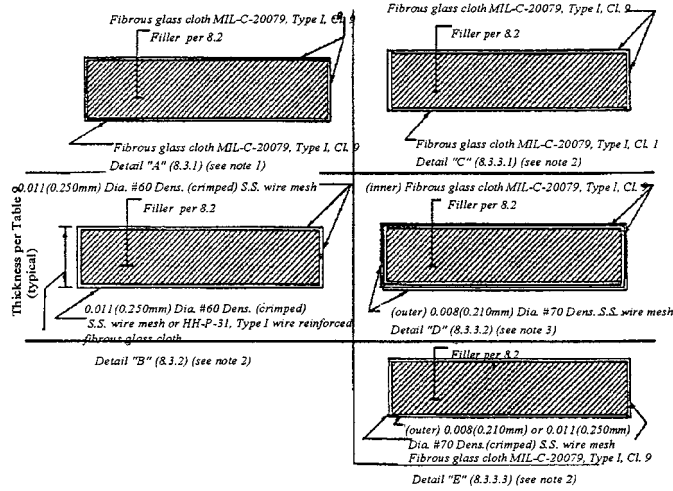

FIG. 17 Typical Removable Flange Cover Where Flange Diameter is Smaller Than the Outside Diameter of the Adjacent Pipe Covering



NOTE 1—For surface temperatures 450°F (232°C) and below.

NOTE 2—For surface temperatures above 450°F (232°C).

FIG. 18 Covering or Encapsulating Materials for Removable Blankets

ASTM F 683

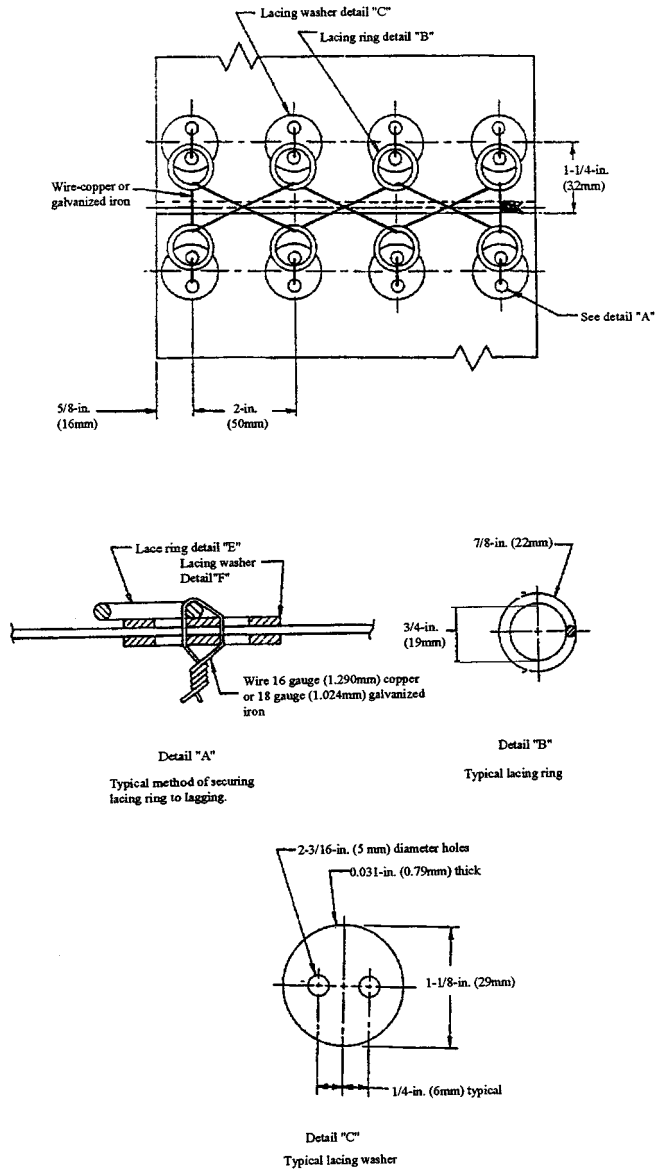

FIG. 19 Typical Method of Lacing Removable Covers Using Lacing Rings

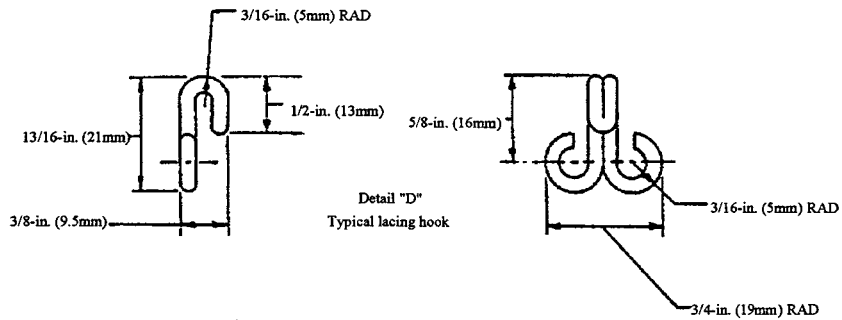
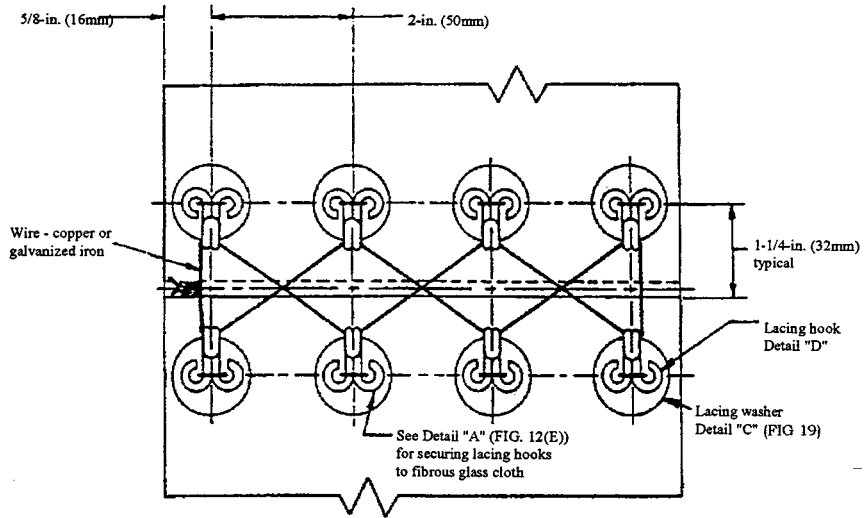

FIG. 20 Typical Method of Lacing Removable Covers Using Lacing Hooks

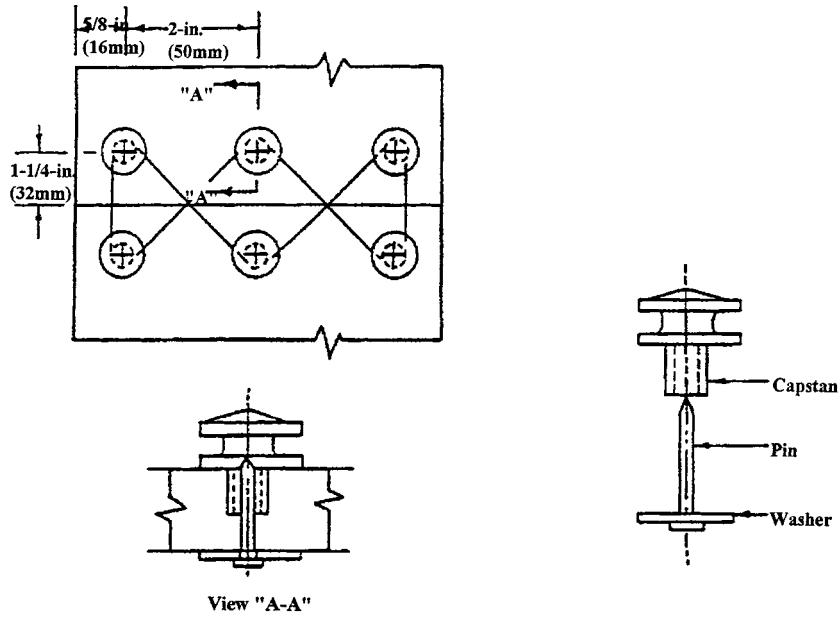

FIG. 21 Alternate Method of Lacing Removable Covers Using Lacing Capstan Assembly Sets

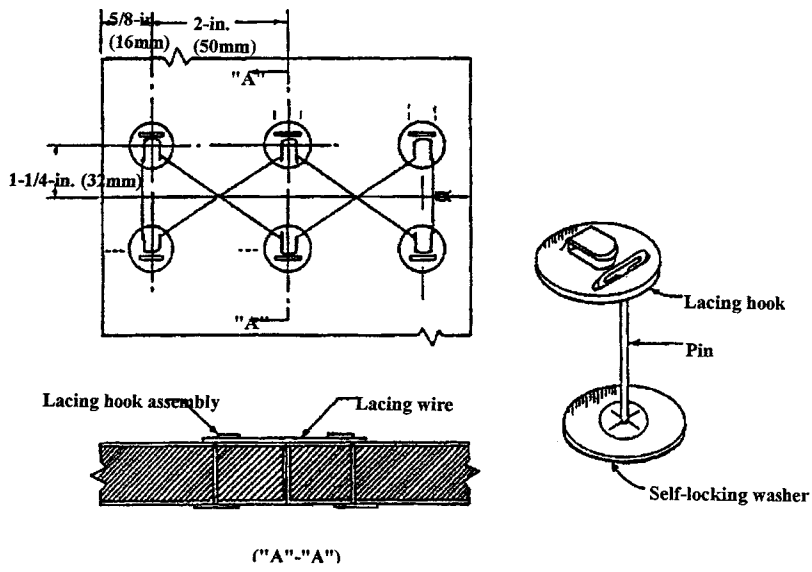
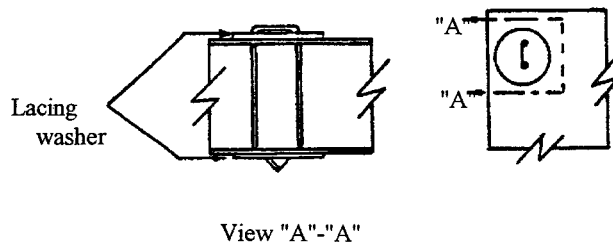
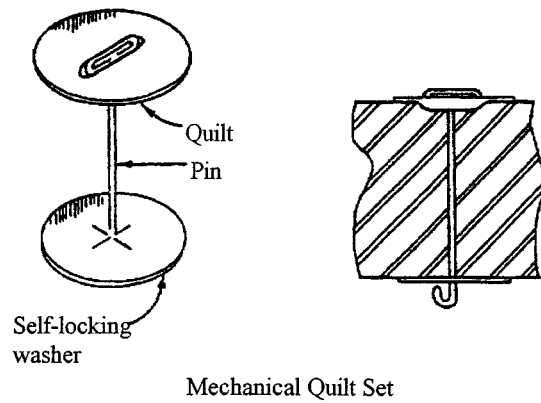

FIG. 22 Alternate Method of Lacing Removable Covers Using Mechanical Hook Sets



Using Lacing Washers
FIG. 23 Typical Methods of Quilting Removable Covers

ANNEX

(Mandatory Information)

A1. SUPPLEMENTAL REQUIREMENTS AND EXCEPTIONS TO THE REQUIREMENTS OF F 683 FOR SHIPS OF THE U.S. NAVY

A1.1 U.S. Navy vessel insulation shall be installed according to details contained in NAVSHIPS drawings 804-5959214 and 804-5959212. Insulation details in this practice are for guidance only.

A1.2 Ceramic fiber insulation (Specification C 892) shall not be installed aboard vessel as per COMNAVSEASYSOM message R 131446Z NOV 86 ZYB, which prohibits the future use of ceramic fiber insulation. Refer to MIL-STD-769 for approved substitutes.

A1.3 Cellular glass block and pipe thermal insulation (Specification C 552) shall not be used.

A1.4 Mineral fiber blanket and felt insulation (Specification C 553) shall not be used. For U.S. Navy applications, use MIL-I-2818 in accordance with MIL-STD-769, Table VI. For passive fire protection applications, refer to NAVSEA drawing No. 803-5184182.

A1.5 Mineral fiber preformed pipe insulation (Specification C 547) shall not be used. Insulate in accordance with MIL-STD-769, Table III.

A1.6 Fibrous glass pipe insulation shall be as specified in

MIL-I-22344 and shall be used only on piping less than 25 mm with maximum temperature limit of 370°F in place of Specification C 547, Class 2. See MIL-STD-769, Table III for restrictions on this material's use.

A1.7 Calcium silicate block and thermal insulation shall be as specified in MIL-I-2819 and MIL-I-2781, respectively, in place of Specification C 533. Insulate in accordance with MIL-STD-769, Tables II and VI.

A1.8 Mineral fiber block and board thermal insulation (Specification C 612) shall not be used.

A1.9 The requirements of 5.4, 5.7, and 5.10 do not apply to U.S. Navy vessels.

A1.10 Thermal insulating tape in accordance with Fig. 6 shall be used only on a temporary basis, such as repair of insulation while the vessel is at sea.

A1.11 Where elastomeric foam insulation is used, the painting requirements of MIL-STD-769 shall be met.

A1.12 The use of "other materials" (provided the requirements of this practice are satisfied) does not apply to U.S. Navy

vessels. See 4.1, Footnote B to Table 1, Footnote A to Table 2, and Footnote B to Table 3.

A1.13 Footnote A to Table 1 and Table 3 does not apply to U.S. Navy vessels.

A1.14 MIL-P-15280 shall not be used on naval vessels; alternatives are as follows:

A1.14.1 For temperature ranges:

-20 to 100°F	EB 4013
100 to 180°F	EB 4013 and DOD-I-24688, Type I, and MIL-I-22344 (see Notes A1.5 and A1.6)
180 to 370°F	DOD-I-24688, Type I and MIL-I-22344 (see Notes A1.5 and A1.6)

A1.15 U.S. Navy limits the use of polyimide foam to 370°F.

The American Society for Testing and Materials takes no position respecting the validity of any patent rights asserted in connection with any item mentioned in this standard. Users of this standard are expressly advised that determination of the validity of any such patent rights, and the risk of infringement of such rights, are entirely their own responsibility.

This standard is subject to revision at any time by the responsible technical committee and must be reviewed every five years and if not revised, either reapproved or withdrawn. Your comments are invited either for revision of this standard or for additional standards and should be addressed to ASTM Headquarters. Your comments will receive careful consideration at a meeting of the responsible technical committee, which you may attend. If you feel that your comments have not received a fair hearing you should make your views known to the ASTM Committee on Standards, 100 Barr Harbor Drive, West Conshohocken, PA 19428.

This standard is copyrighted by ASTM, 100 Barr Harbor Drive, West Conshohocken, PA 19428-2959, United States. Individual reprints (single or multiple copies) of this standard may be obtained by contacting ASTM at the above address or at 610-832-9585 (phone), 610-832-9555 (fax), or service@astm.org (e-mail); or through the ASTM website (<http://www.astm.org>).