



Standard Specification for Doors, Furniture, Marine¹

This standard is issued under the fixed designation F 782; the number immediately following the designation indicates the year of original adoption or, in the case of revision, the year of last revision. A number in parentheses indicates the year of last reappraisal. A superscript epsilon (ϵ) indicates an editorial change since the last revision or reappraisal.

This standard has been approved for use by agencies of the Department of Defense. Consult the DoD Index of Specifications and Standards for the specific year of issue which has been adopted by the Department of Defense.

1. Scope

1.1 This specification covers the construction of furniture doors for use where invoked by other marine furniture specifications.

1.2 This specification applies to all furniture doors for marine furniture, in items requiring hinged doors.

1.3 Values stated in inch-pound units are to be regarded as the standard. The metric equivalents, given in parentheses, are for information only.

2. Referenced Documents

2.1 ASTM Standards:

A 240 Specification for Heat-Resisting Chromium and Chromium-Nickel Stainless Steel Plate, Sheet, and Strip for Pressure Vessels²

A 366/A 366M Specification for Steel, Sheet, Carbon, Cold-Rolled, Commercial Quality²

A 582 Specification for Free-Machining Stainless and Heat-Resisting Steel Bars, Hot-Rolled or Cold-Finished³

B 209 Specification for Aluminum and Aluminum-Alloy Sheet and Plate⁴

B 221 Specification for Aluminum and Aluminum-Alloy Extruded Bars, Rods, Wire, Shapes, and Tubes⁴

C 1036 Specification for Flat Glass⁵

D 907 Terminology of Adhesives⁶

2.2 American Institute of Steel Construction Manual:⁷

AISC Wire and Sheet Metal Gages—Equivalent Thickness in Decimals of an Inch, U.S. Standard Gage (USSG) for Uncoated Hot and Cold-Rolled Sheets

2.3 Federal Specifications:⁸

DD-G-1403 Glass, Plate (Float), Sheet Figured, and Spandrel (Heat Strengthened and Fully Tempered)

¹ This specification is under the jurisdiction of ASTM Committee F-25 on Shipbuilding and is the direct responsibility of Subcommittee F25.03 on Outfitting. Current edition approved Feb. 15, 1995. Published April 1995. Originally published as F 782 – 82. Last previous revision F 782 – 94.

² Annual Book of ASTM Standards, Vol 01.03.

³ Annual Book of ASTM Standards, Vol 01.05.

⁴ Annual Book of ASTM Standards, Vol 02.02.

⁵ Annual Book of ASTM Standards, Vol 15.02.

⁶ Annual Book of ASTM Standards, Vol 15.06.

⁷ Available from the American Institute of Steel Construction, 400 N. Michigan Ave., Chicago, IL 60611.

⁸ Available from Standardization Documents Order Desk, Bldg. 4 Section D, 700 Robbins Ave., Philadelphia, PA 19111-5094, Attn: NPODS.

LP-391 Plastic Sheets, Rods and Tubing, Rigid Cast, Methacrylate (Multiapplication)

QQ-C-320 Chromium Plating (Electrodeposited)

QQ-Z-325 Zinc Coating, Electrodeposited

2.4 American National Standard Institute Standards:⁹

ANSI Z97.1-1975 Safety Performance Specifications and Methods of Test for Safety Glazing Material Used in Buildings

3. Terminology

3.1 Descriptions of Terms Specific to This Standard:

3.1.1 *flush doors*—metal doors with a smooth surface on the exterior face.

3.1.2 *hinged door*—door equipped with hinges that permit it to swing about the vertical hinge axis, either right hand or left hand.

3.1.2.1 *right-hand door*—door with hinges on the right side when viewed from the exterior of the furniture item containing the door.

3.1.2.2 *left-hand door*—door with hinges on the left side when viewed from the exterior of the furniture item containing the door.

3.1.3 *panel doors*—doors with metal stiles and rails that support a panel insert of transparent safety glazing or expanded aluminum.

3.1.3.1 *stiles*—the vertical members in the frame of a panel door that support the central panel.

3.1.3.2 *rails*—the horizontal members in the frame of a panel door that support the central panel.

4. Classification

4.1 Doors shall be of the following types as required by the specifications for the item of furniture in which they are installed and as indicated in ordering documents. See Fig. 1 for details.

4.1.1 *Type I*—Flush hinged door.

4.1.2 *Type II*—Panel hinged door.

5. Ordering Information

5.1 Doors are included as part of the orders for items of furniture requiring doors. To describe adequately the door or

⁹ Available from American National Standards Institute, 11 W. 42nd St., 13th Floor, New York, NY 10036.

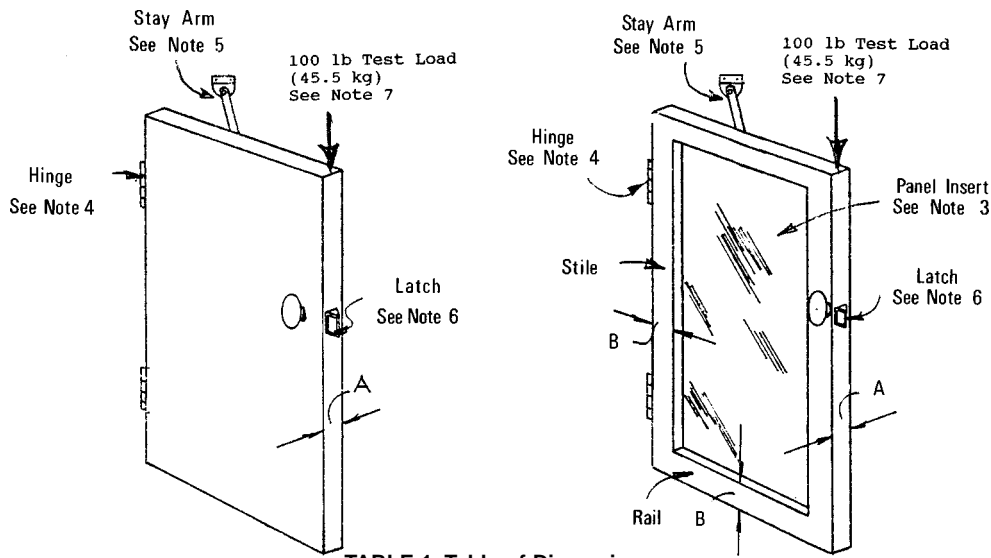

TABLE 1 Table of Dimensions

Designation	Dimensions	
	in.	mm
Door thickness	A	1 max 25.4 max
Width of stile or height of rail	B	3 max 76.2 max

NOTE 1—Panels of Type I (flush) doors shall be cold-rolled sheet steel, commercial quality, furniture grade in accordance with Specification 366/A 366M, 18 USSG (0.0478 in. or 1.21 mm). Stiffeners shall be applied to front and back as required to prevent buckling or oil-canning.

NOTE 2—At the option of the furniture manufacturer the stiles and rails for Type II (panel) door, may be either 18 USSG (0.0478 in. or 1.21 mm) cold-rolled steel, commercial quality, furniture grade in accordance with Specification A 366/A 366M or Type 6063-T6 extruded aluminum in accordance with Specification B 221 or 0.064-in. (1.63-mm) thick Type 5052-H32 aluminum alloy sheet in accordance with Specification B 209.

NOTE 3—Panel inserts for Type II (panel) doors shall be Type 3003-H14 anodized aluminum, 0.081 in. (2.06 mm) thick before expanding and of the Festoon or other approved pattern. Material shall be in accordance with Specification B 209 and the anodizing shall be done after metal is expanded. Alternative safety glazing can be furnished if specified in ordering documents. See 6.11.2.1 for description of these alternatives.

NOTE 4—Butt hinges are shown in Fig. 1 and shall be furnished in accordance with 6.8. Type 300 stainless steel pivot or hinges of adequate strength may be used in place of butt hinges.

NOTE 5—Stay arms shall be provided and shall both prevent door from opening more than 90° and be capable of retaining door in 90° open position.

NOTE 6—Doors shall be equipped with latches. See 6.7.1 and 6.7.2 for description of alternative latches.

NOTE 7—Doors shall be capable of resisting vertical load applied at latch edge. See 7.1 for detail of test.

NOTE 8—Doors shall be comply with requirements of tilt test. See 7.2 for details of test.

FIG. 1 Furniture Doors

doors required, these orders shall include, as necessary, the following information:

5.1.1 Type.

5.1.2 Size, see Section 8.

5.1.3 Paint:

5.1.3.1 Color—Doors shall be painted to match the furniture item in which they are installed.

5.1.3.2 Manufacturer's standard baked enamel will be furnished unless otherwise required and indicated by the purchaser.

5.1.4 For single-hinged doors, indicate hand if not obvious or if a specific hand is required.

5.1.5 Material for Type II (panel) doors may be either steel or aluminum. Material selected shall be the option of the furniture purchaser.

6. Materials and Manufacture

6.1 For typical design, see Fig. 1.

6.2 Sheet metal shall be cold-rolled steel, commercial qual-

ity, furniture grade in accordance with Specification A 366/A 366M.

6.3 Aluminum extrusions shall be Type 6063-T6 aluminum alloy in accordance with Specification B 221. Aluminum sheet shall be Type 5052-H32 aluminum alloy in accordance with Specification B 209.

6.4 Joining of metal parts:

6.4.1 Metal components shall be joined by welding or gluing with a structural adhesive as defined in Terminology D 907.

6.4.2 Joining shall be adequate to prevent racking during handling.

6.4.3 Spotwelds shall be spaced approximately 3 in. (76.2 mm) on centers.

6.4.4 Visible spotwelds on exterior face of door higher than the general surface of the metal shall be ground flush.

6.4.5 Visible spotweld depressions shall be spot filled and sanded flush.

6.5 All doors shall be square and form a plane through the four corners.

6.6 All doors shall incorporate a latch or other positive means to prevent opening in heavy seas. Spring, bullet, magnetic, or bayonet-type catches shall not be permitted. Furniture doors shall not open when furniture unit in which door is installed is tilted a maximum of 30° from the vertical.

6.7 Latches for doors shall be one of the two following types as selected by the furniture purchaser:

6.7.1 Mortise type of brass, bronze, or stainless steel, attached with stainless steel fasteners. Exposed brass or yellow bronze parts shall be Class 1, Type II chrome plated in accordance with Federal Specification QQ-C-320. Exposed stainless steel and white bronze parts shall have a brushed finish. White bronze shall be covered with a clear protective coating of lacquer or other similar covering.

6.7.2 Two point latching rod system with hardware similar to that in use for marine type furniture doors. Disk tumbler cam locks may be used to prevent rods from unlatching. Omit dummy hardware on inactive door for double door applications. Disk tumbler cam locks shall have 90° rotation with screwed on or spun-on cap attachment. Cylinders shall be die-cast zinc with exposed surfaces finished in satin nickel-plated US-15 finish.

6.8 Hinges shall be provided and shall be Type 300 stainless steel in accordance with Specification A 240 with a Type 300 stainless steel pin in accordance with Specification A 582. Hinges shall be 2 in. (50.8 mm) high with 1/16-in. (1.59-mm) thick leaves and secured with Type 300 stainless steel or zinc-plated steel fasteners. Zinc-plated fasteners shall be in accordance with QQ-Z-325 Cl 2, Ty 1. Type 300 stainless steel pivot or piano hinges of adequate strength may be used in place of butt hinges.

6.9 Stay arms shall be provided and shall prevent door from opening more than 90° and be capable of retaining door in 90° open position.

6.10 Type I (flush) doors shall have additional requirements as follows:

6.10.1 Front and back panels shall be cold-rolled sheet steel, commercial quality, furniture grade in accordance with Specification A 366/A 366M, 18 USSG (0.0478 in. or 1.21 mm).

6.10.2 Stiffener shall be applied to front and back panels as required to prevent buckling or oil-canning.

6.11 Type II (panel) doors shall have the additional requirements as follows:

6.11.1 At the option of the furniture manufacturer, the stiles and rails may be either 18 U.S.S.G (0.0478-in. 1.21-mm) cold-rolled steel, commercial quality, furniture grade in accordance with Specification A 366/A 366M, Type 6063-T6 extruded aluminum alloy in accordance with Specification B 221, or 0.064-in. (1.63-mm) thick Type 5052-H32 aluminum alloy sheet in accordance with Specification B 209.

6.11.2 *Panel Inserts*—Unless otherwise specified in ordering documents, panel inserts shall be expanded aluminum in accordance with 6.11.2.2.

6.11.2.1 Panel inserts of transparent safety glazing shall be either 1/4-in. (6.35-mm) thick safety glass, of the heat-treated or laminated type, or 3/16-in. (4.76-mm) thick acrylic sheet.

Material specifications for these transparent panel inserts are as follows: heat-treated safety glass in accordance with Specification C 1036 and Federal Specification DD-G-1403; laminated safety glass in accordance with Specification C 1036; acrylic sheet in accordance with Federal Specification LP-391. In addition, all transparent safety glazing shall meet the pertinent safety requirements of ANSI Specification Z97.1-1975.

6.11.2.2 Expanded aluminum panel inserts shall be Type 3003-H14 anodized aluminum, 0.081 in. (2.06 mm) thick before expanding, and of the Festoon or other approved pattern. Material shall be in accordance with Specification B 209 and the anodizing shall be done after metal is expanded.

6.11.3 Provision for supporting and replacing the panel inserts shall be made.

7. Performance Requirements

7.1 Doors shall be capable of supporting a vertical load of 100 lb (45.4 kg), applied at the lock edge of door, with door in any position from 10° open to 90° open. Load shall remain on door for a minimum of 3 min and there shall be no indication of permanent set after removal of load.

7.2 *Tilt Test*—Doors shall remain latched in closed position when the furniture unit in which they are installed is tilted 30° from the vertical in the plane that would induce the greatest tendency for door to open. Leave door in this attitude for a minimum of three minutes.

8. Dimensions

8.1 For dimensions, see Table of Dimensions under Fig. 1.

8.2 Doors shall be made to a size that suits the furniture item in which they are installed.

9. Workmanship, Finish, and Quality Assurance

9.1 All workmanship and material shall be of specified quality in keeping with the best commercial marine practice to produce each item for its intended use.

9.2 All exposed burrs, raw, or sharp edges that might be injurious to personnel shall be removed.

9.3 Depressions considered unacceptable for product's end use shall be spot filled and sanded smooth.

9.4 *Finish*:

9.4.1 All steel surfaces, unless corrosion-resistant or with a corrosion-resistant plating, shall be painted so as to prevent corrosion.

9.4.2 Unless otherwise required by the furniture specification, all normally visible parts of completed unit shall have the manufacturer's standard baked-on enamel finish.

9.4.3 *Color*—Doors shall be painted to match the furniture item in which they are installed.

10. Inspection and Certification

10.1 Inspection and certification requirements of furniture item in which door (or doors) are installed shall govern.

11. Packaging and Package Marking

11.1 Each door shall be installed in its respective furniture item prior to shipment. Marking and packaging requirements of furniture item shall govern.

12. Keywords

12.1 doors; flush hinged door; furniture; furniture doors;
hinged doors; marine; marine furniture; panel hinged door;
ship

The American Society for Testing and Materials takes no position respecting the validity of any patent rights asserted in connection with any item mentioned in this standard. Users of this standard are expressly advised that determination of the validity of any such patent rights, and the risk of infringement of such rights, are entirely their own responsibility.

This standard is subject to revision at any time by the responsible technical committee and must be reviewed every five years and if not revised, either reapproved or withdrawn. Your comments are invited either for revision of this standard or for additional standards and should be addressed to ASTM Headquarters. Your comments will receive careful consideration at a meeting of the responsible technical committee, which you may attend. If you feel that your comments have not received a fair hearing you should make your views known to the ASTM Committee on Standards, 100 Barr Harbor Drive, West Conshohocken, PA 19428.