



# Standard Specification for Gong, Sound Signaling<sup>1</sup>

This standard is issued under the fixed designation F 957; the number immediately following the designation indicates the year of original adoption or, in the case of revision, the year of last revision. A number in parentheses indicates the year of last approval. A superscript epsilon ( $\epsilon$ ) indicates an editorial change since the last revision or reapproval.

*This standard has been approved for use by agencies of the Department of Defense.*

## 1. Scope

1.1 This specification covers gongs for use on ships 100 m or more in length, as required by International Regulations (see Appendix X1).

1.2 For consistency with International Regulations, all measurements are in SI units.

## 2. Referenced Documents

### 2.1 ASTM Standards:

A 167 Specification for Stainless and Heat-Resisting Chromium-Nickel Steel Plate, Sheet, and Strip<sup>2</sup>

A 276 Specification for Stainless Steel Bars and Shapes<sup>2</sup>

D 3951 Practice for Commercial Packaging<sup>3</sup>

### 2.2 American Welding Society Standard:

AWS D1.1 Structural Welding Code<sup>4</sup>

### 2.3 Federal Specifications:<sup>5</sup>

PPP-B-576 Box, Wood, Cleated, Veneer, Paper Overlaid

PPP-B-585 Boxes, Wood, Wirebound

PPP-B-591 Boxes, Fiberboard, Wood-cleated

PPP-B-601 Boxes, Wood, Cleated Plywood

PPP-B-621 Boxes, Wood, Nailed and Lock Corner

### 2.4 Military Standard:<sup>5</sup>

MIL-STD-129 Marking for Shipment and Storage

## 3. Ordering Information

3.1 Orders for gongs under this specification shall include the following information:

3.1.1 ASTM designation and year of issue.

3.1.2 Number of gongs.

3.1.3 Packaging and marking, if other than commercial.

<sup>1</sup> This specification is under the jurisdiction of ASTM Committee F25 on Shipbuilding and is the direct responsibility of Subcommittee F25.07 on General Requirements.

Current edition approved March 15, 1991. Published August 1991. Originally published as F 957 – 85. Last previous edition F 957 – 87.

<sup>2</sup> *Annual Book of ASTM Standards*, Vol 01.03.

<sup>3</sup> *Annual Book of ASTM Standards*, Vol 15.09.

<sup>4</sup> Available from the American Welding Society, 550 N. W. Le Jeune Rd., Miami, FL 33126.

<sup>5</sup> Available from Standardization Documents Order Desk, Bldg. 4 Section D, 700 Robbins Ave., Philadelphia, PA 19111-5094, Attn: NPODS.

## 4. Materials and Manufacture

### 4.1 Materials:

4.1.1 The gong cylinder, brackets, clapper rod, “U” bracket, washers, and clapper support pin shall be of stainless steel, in accordance with Specification A 167, UNS number S31600.

4.1.2 The clapper mass shall be of cast alloy steel in accordance with Specification A 276, UNS S31600.

4.1.3 The support bolt, nut, flat washer, and cotter pins shall be of stainless steel compatible with the other materials.

### 4.2 Welding:

4.2.1 Welding shall be of the type and sizes shown in Fig. 1 and Fig. 2, and in accordance with Standard AWS D1.1.

### 4.3 Manufacture:

4.3.1 Fig. 1 shows the general arrangement of the assembled gong, as well as details of the gong cylinder. Fig. 2 shows details of the brackets, clapper, and miscellaneous fittings.

4.3.2 The gong cylinder may be made from two pieces welded together, instead of one piece. Two piece construction shall be annealed to remove residual stresses.

4.3.3 Sharp corners and edges of the cylinder shall be broken.

4.3.4 The two brackets shall be welded together before being welded to the cylinder. The flanged ends of the brackets may be left straight and not shaped to the cylinder.

4.3.5 The clapper mass shall be welded to the clapper rod before forming the second eye.

### 4.4 Extra Parts:

4.4.1 Two extra supporting nuts and flat washers shall be furnished with each gong.

## 5. Acoustic Requirements

5.1 The sound characteristics shall produce a sound pressure level of not less than 110 dB at a distance of 1 m.

## 6. Dimensions and Tolerances

6.1 Dimensions shall conform to Fig. 1 and Fig. 2.

6.2 Tolerances shall be as follows:

6.2.1 Up to 10 mm:  $\pm 1$  mm.

6.2.2 10 mm to 50 mm:  $\pm 2$  mm.

6.2.3 Over 50 mm:  $\pm 3$  mm.

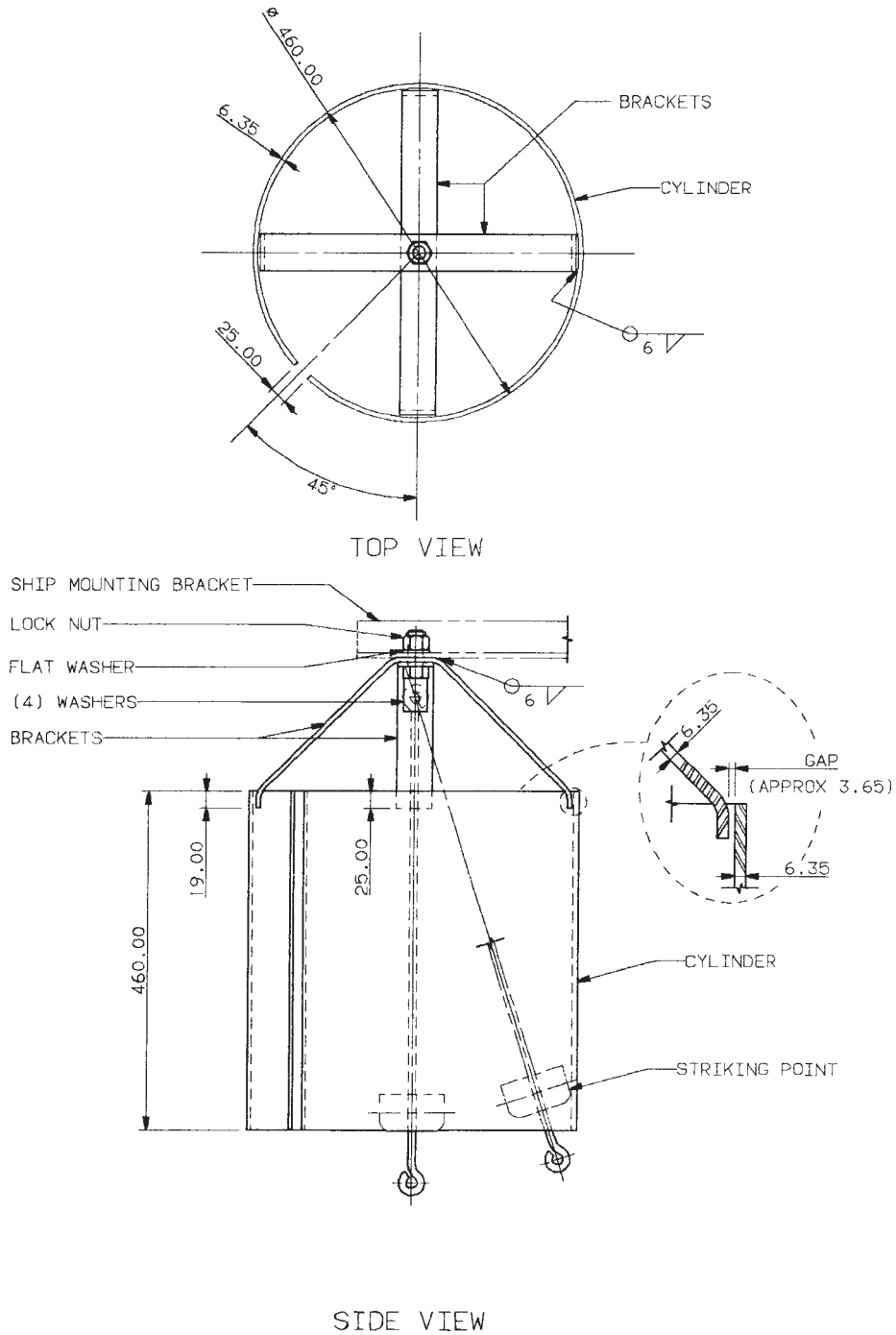

NOTE—All dimensions in millimetres.  
**FIG. 1 Assembly of Gong**

**7. Workmanship, Finish, and Appearance**

7.1 Gongs shall be free from cracks, burrs, sharp cutting edges, and other defects affecting their life, appearance, and serviceability.

**8. Sampling**

8.1 For orders of 1 or 2 gongs, each gong shall be inspected and tested.

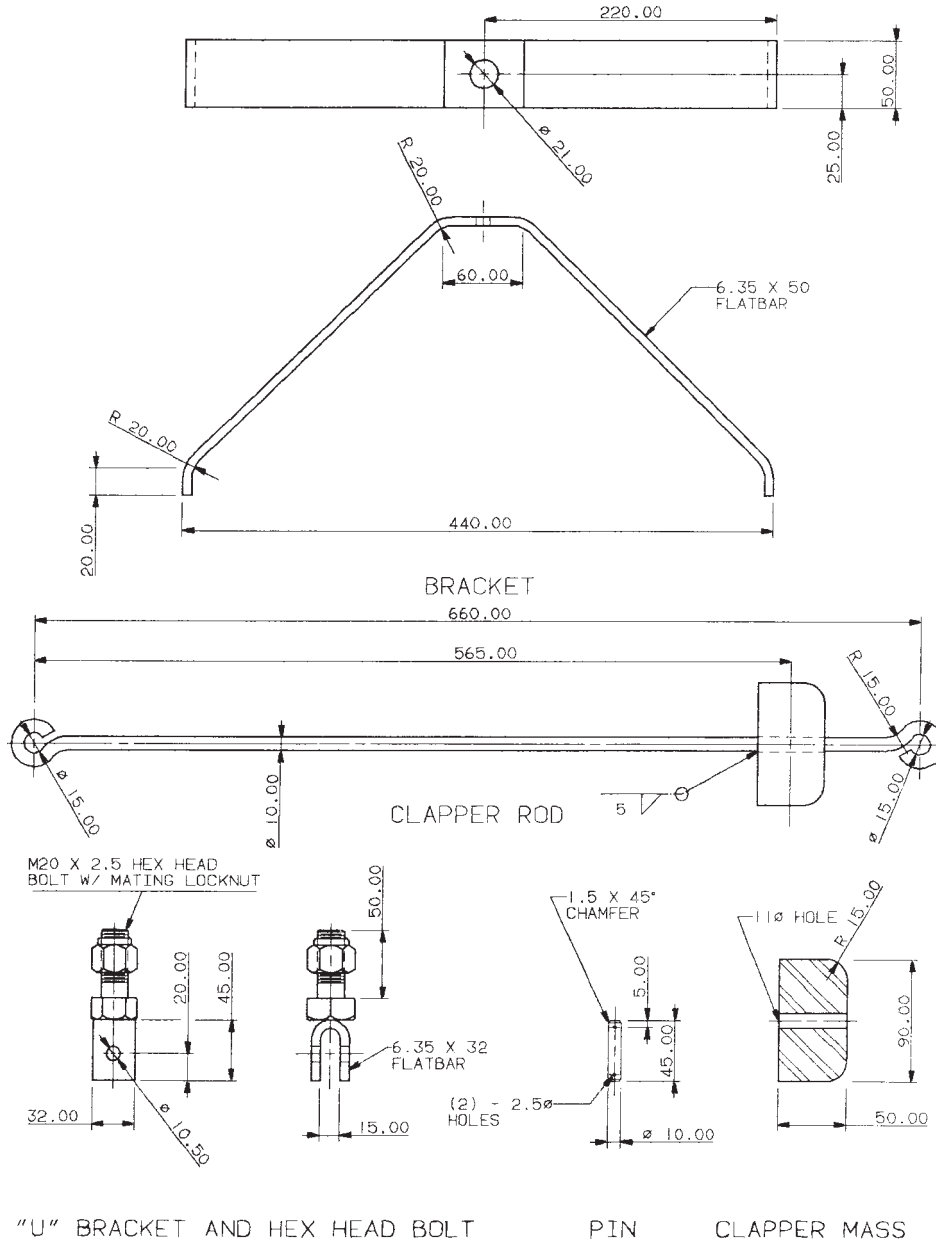

NOTE—All dimensions in millimetres.

FIG. 2 Miscellaneous Details

8.2 For orders of 3 to 10 gongs, 2 gongs shall be selected at random. If any one of them fails to meet requirements, then all gongs in the order shall be inspected and tested.

8.3 For orders of more than 10 gongs, they shall be separated into groups of 10 (or fraction thereof) for sampling purposes.

## 9. Inspection and Testing

9.1 *Responsibility*—Unless otherwise specified in the purchase order, the manufacturer shall be responsible for the performance of all inspection and testing specified herein. The manufacturer may utilize his own facilities or any commercial facility acceptable to the purchaser. The purchaser reserves the

right to perform any of the inspections and tests set forth where such are deemed necessary to ensure that supplies conform to prescribed requirements. Nonconforming gongs shall not be offered for delivery.

9.2 *Inspection*—The dimensions of the gong and its components shall be checked to ensure that they are within specified tolerances.

9.3 *Acoustic Test*—Each gong tested shall be supported as shown in Fig. 1 with the clapper in place. The gong shall be rung by striking the cylinder with the clapper, activated by a lanyard. The sound, produced in accordance with Appendix X1, shall be measured in a space with no large sound reflecting surfaces (except the floor) that are within 10 m. The sound shall

be measured using a commercial sound level meter located at a distance of 1 m and at a height above the floor equal to that of the striking point.

**10. Product Marking**

10.1 The letters “ASTM” and this specification number shall be engraved on the gong cylinder in figures at least 6 mm high.

10.2 The manufacturer may engrave his brand name or logo on the inside of the gong cylinder.

**11. Packaging and Package Marking**

11.1 No preservation is required.

11.2 Unless otherwise specified, packaging and marking shall conform to Practice D 3951 and shall, when specified, include bar code marking.

11.3 For government procurements for long-term storage or overseas shipment, the requirements of Annex A1 apply. In such case the required level of packaging shall be specified.

**12. Supersession**

12.1 This specification is intended to supersede Bureau of Ships drawing S2408-F-921899. The cancellation of Bureau of Ships S2408-F-921899 drawing and adoption of this specification can only be effected by the Navy.

NOTE 1—The Bureau of Ships was one of the predecessors of the Naval Ship/Sea Systems Command.

**13. Keywords**

13.1 clapper; gong; gong cylinder; signaling; sound signaling

**ANNEX**

**(Mandatory Information)**

**A1. PACKING FOR DOD PROCUREMENTS**

A1.1 Applicable documents for this annex only.

A1.1.1 *Federal Specifications*—PPP-B-576, PPP-B-585, PPP-B-591, PPP-B-601, and PPP-B-621.

A1.1.2 *Military Standard*—MIL-STD-129.

A1.2 *Preservation*—None required.

A1.3 *Packing*—The gong shall be cushioned, blocked, or braced within the container in a manner to prohibit movement, and the clappers shall be secured or cushioned to prevent knocking. Unless otherwise specified in the purchase order, one gong shall be packed per container. When more than one gong is required to be packed in each container, the gross mass of the wood or wood-cleated boxes shall not exceed approximately 100 kg (220 lbs).

A1.3.1 *Level A*—Gongs shall be packed in containers conforming to any one of the following specifications at the option of the manufacturer:

Specification	Type or Class
PPP-B-585	Class 3
PPP-B-601	Overseas
PPP-B-621	Class 2

A1.3.1.1 Boxes shall be closed and banded in accordance with the applicable box specification.

A1.3.2 *Level B*—Gongs shall be packed in boxes conforming to any of the following specifications at the option of the manufacturer.

Specification	Type or Class
PPP-B-576	Class 2
PPP-B-585	Class 1 or 2
PPP-B-591	Weather-resistant
PPP-B-601	Domestic
PPP-B-621	Class 1

A1.3.2.1 Box closures shall be as specified in the applicable box specification.

A1.3.3 *Level C*—Gongs shall be packed and have container closure as specified for Level B, except that containers may be of the domestic type or class.

A1.3.4 Commercial packing shall conform to 11.2.

A1.4 *Marking*—In addition to any special marking required by the order, shipments shall be marked in accordance with MIL-STD-129 or Practice D 3951 as applicable and when specified shall include bar code markings.

**APPENDIX**
**(Nonmandatory Information)**
**X1. EXCERPTS FROM U. S. COAST GUARD RULES**

X1.1 For general information, the following is quoted from U. S. Coast Guard Commandant Instruction M16672.2A: Navigation Rules, International-Inland.

X1.1.1 *Division II, Part D, Rule 33—Equipment for Sound Signals:*

X1.1.1.1 A vessel of 12 m or more in length shall be provided with a whistle and a bell and a vessel of 100 m or more in length shall, in addition, be provided with a gong, the tone and sound of which cannot be confused with that of the bell. The whistle, bell, and gong shall comply with the specifications in Annex III to these regulations. The bell or gong, or both, may be replaced by other equipment having the same respective sound characteristics, provided that manual sounding of the required signals shall always be possible.

X1.1.1.2 A vessel of less than 12 m in length shall not be obliged to carry the sound signalling appliances prescribed in X1.2.1 of this rule but if she does not, she shall be provided with some other means of making an efficient sound signal.

X1.1.2 *Division II, Part E, Annex III—Technical Details of Sound Signal Appliances: International Rules:*

X1.1.2.1 *Whistles* (not germane to this specification. Therefore, not quoted).

X1.1.2.2 *Bell or Gong:*

(a) *Intensity of Signal*—A bell or gong, or other device having similar sound characteristics shall produce a sound pressure level of not less than 110 dB at a distance of 1 m from it.

(b) *Construction*—Bells and gongs shall be made of corrosion-resistant material and designed to give a clear tone. The diameter of the mouth of the bell shall be not less than 300 mm for vessels of 20 m or more in length, and shall be not less than 200 mm for vessels of 12 m or more but of less than 20 m in length. Where practicable, a power-driven bell striker is recommended to ensure constant force but manual operation shall be possible. The mass of the striker shall be not less than 3 % of the mass of the bell.

X1.1.2.3 *Approval*—The construction of sound signal appliances, their performance and their installation on board the vessel shall be to the satisfaction of the appropriate authority of the state whose flag the vessel is entitled to fly.

X1.1.3 *Division II, Part E, Subpart B—Bell or Gong—Inland Rules:*

X1.1.3.1 *Intensity of Signal*—A bell or gong, or other device having similar sound characteristics shall produce a sound pressure level of not less than 110 dB at 1 m.

X1.1.3.2 *Construction*—Bells and gongs shall be made of corrosion-resistant material and designed to give a clear tone. The diameter of the mouth of the bell shall be not less than 300 mm for vessels of more than 20 m in length, and shall be not less than 200 mm for vessels of 12 to 20 m in length. The mass of the striker shall be not less than 3 % of the mass of the bell. The striker shall be capable of manual operation.

NOTE X1.1—When practicable, a power-driven bell striker is recommended to ensure constant force.

*The American Society for Testing and Materials takes no position respecting the validity of any patent rights asserted in connection with any item mentioned in this standard. Users of this standard are expressly advised that determination of the validity of any such patent rights, and the risk of infringement of such rights, are entirely their own responsibility.*

*This standard is subject to revision at any time by the responsible technical committee and must be reviewed every five years and if not revised, either reapproved or withdrawn. Your comments are invited either for revision of this standard or for additional standards and should be addressed to ASTM Headquarters. Your comments will receive careful consideration at a meeting of the responsible technical committee, which you may attend. If you feel that your comments have not received a fair hearing you should make your views known to the ASTM Committee on Standards, at the address shown below.*

*This standard is copyrighted by ASTM, 100 Barr Harbor Drive, PO Box C700, West Conshohocken, PA 19428-2959, United States. Individual reprints (single or multiple copies) of this standard may be obtained by contacting ASTM at the above address or at 610-832-9585 (phone), 610-832-9555 (fax), or service@astm.org (e-mail); or through the ASTM website (www.astm.org).*