



## Standard Specification for Valve Locking Devices<sup>1</sup>

This standard is issued under the fixed designation F 993; the number immediately following the designation indicates the year of original adoption or, in the case of revision, the year of last revision. A number in parentheses indicates the year of last approval. A superscript epsilon ( $\epsilon$ ) indicates an editorial change since the last revision or reapproval.

*This standard has been approved for use by agencies of the Department of Defense.*

### 1. Scope

1.1 This specification<sup>2</sup> covers the application, design, and materials for valve locking devices.

1.2 Locking devices Types I and II described in this specification are designed to secure the valve in a fully opened or completely closed position.

1.3 This specification does not apply to valves equipped with locking devices from the valve manufacturer, unless this standard is invoked in the procurement ordering data for the valve or its locking device, or both.

1.4 This specification is intended to supercede NASEA drawing S4824-1385509. However, cancellation of that drawing and adoption of this specification can only be effected by the navy.

### 2. Referenced Documents

#### 2.1 ASTM Standards:

- A 36/A36M Specification for Carbon Structural Steel<sup>3</sup>
- A 167 Specification for Stainless and Heat-Resisting Chromium-Nickel Steel Plate, Sheet, and Strip<sup>4</sup>
- A 492 Specification for Stainless Steel Rope Wire<sup>4</sup>
- A 668/A 668M Specification for Steel Forgings, Carbon and Alloy, for General Industrial Use<sup>5</sup>
- B 209 Specification for Aluminum and Aluminum-Alloy Sheet and Plate<sup>6</sup>
- B 580 Specification for Anodic Oxide Coatings on Aluminum<sup>7</sup>
- F 708 Practice for Design and Installation of Rigid Pipe Hangers<sup>8</sup>

#### 2.2 Other Documents:

<sup>1</sup> This specification is under the jurisdiction of ASTM Committee F25 on Ships and Marine Technology and is the direct responsibility of Subcommittee F25.11 on Machinery and Piping Systems.

Current edition approved March 27, 1986. Published June 1986.

<sup>2</sup> This specification is intended to supersede NAVSEA Drawing S4824-1385509. However, cancellation of that drawing and adoption of this specification can only be effected by the Navy.

<sup>3</sup> *Annual Book of ASTM Standards*, Vol 01.04.

<sup>4</sup> *Annual Book of ASTM Standards*, Vol 01.03.

<sup>5</sup> *Annual Book of ASTM Standards*, Vol 01.05.

<sup>6</sup> *Annual Book of ASTM Standards*, Vol 02.02.

<sup>7</sup> *Annual Book of ASTM Standards*, Vol 02.05.

<sup>8</sup> *Annual Book of ASTM Standards*, Vol 01.07.

ANSI B18.1 Small Solid Rivets<sup>9</sup>  
American Welding Society D1.1 on Steel<sup>10</sup>

### 3. Classification

3.1 Valve locking devices shall be classified by the following types and grades in accordance with the method of locking and material used.

#### 3.2 Types:

- 3.2.1 *Type I*—Wire rope assembly (see Fig. 1 Fig. 2).
- 3.2.2 *Type II*—Handwheel latch (see Fig. 3 Fig. 4).
- 3.2.3 *Type III*—Locking shield (see Fig. 5).

#### 3.3 Grades:

- 3.3.1 *Grade A*—Stainless steel, Specification A 167, Type 316.
- 3.3.2 *Grade B*—Anodized aluminum, Specification B 209, Alloy 5052.
- 3.3.3 *Grade C*—Carbon steel, commercial quality steel (see Specification A 36/A36M).

### 4. Ordering Information

4.1 Orders for material under this specification shall include the following:

- 4.2 ASTM Designation and year of issue.
- 4.3 *Type*.
- 4.4 *Grade*.
- 4.5 *Padlock Size* (if necessary).
- 4.6 *Rubber Coating* (if necessary).
- 4.7 *Necessary Dimensions*:
  - 4.7.1 *Type I*:
    - 4.7.1.1 Length of wire strand.
    - 4.7.1.2 Diameter of pipe.
  - 4.7.2 *Type II*:
    - 4.7.2.1 Maximum height (fully opened).
    - 4.7.2.2 Minimum height (fully closed).
    - 4.7.2.3 Handwheel thickness.
    - 4.7.2.4 Handwheel depth.
    - 4.7.2.5 Diameter at location of attachment.

<sup>9</sup> Available from American National Standards Institute, 25 W. 43rd St., 4th Floor, New York, NY 10036.

<sup>10</sup> Available from American Welding Society, 550 N.W. LeJeune Rd., Miami, FL 33126.

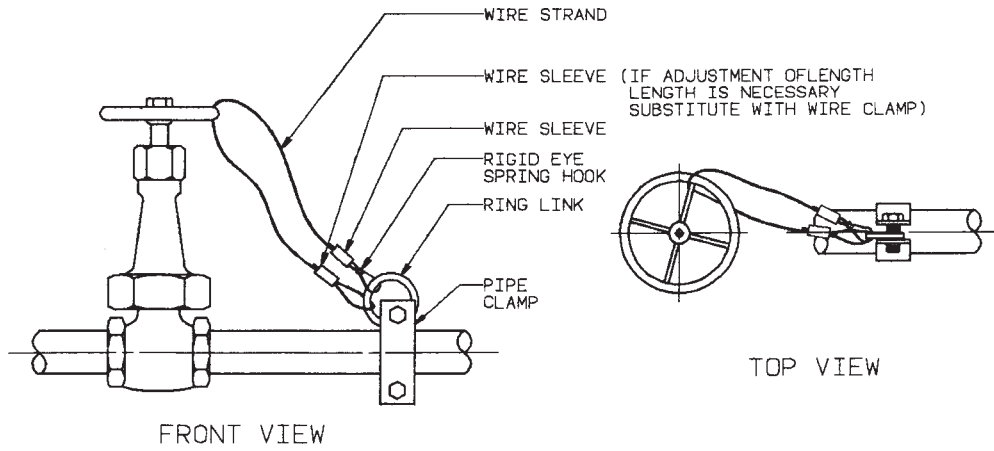
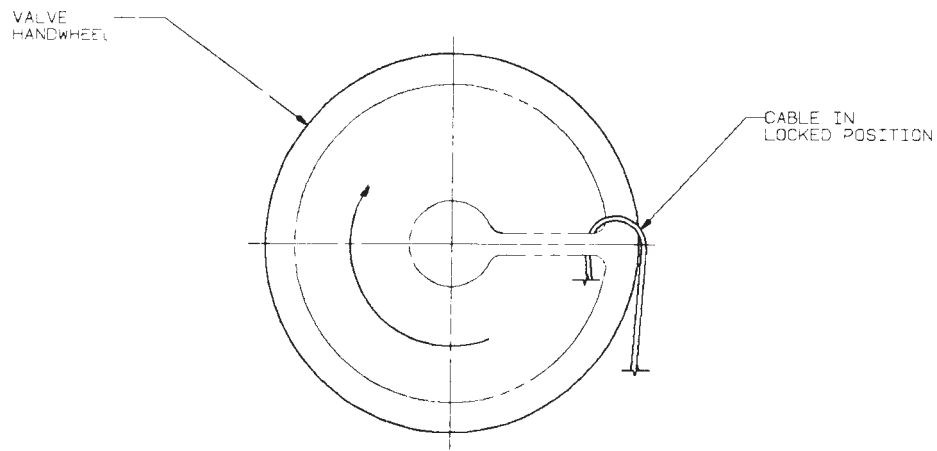
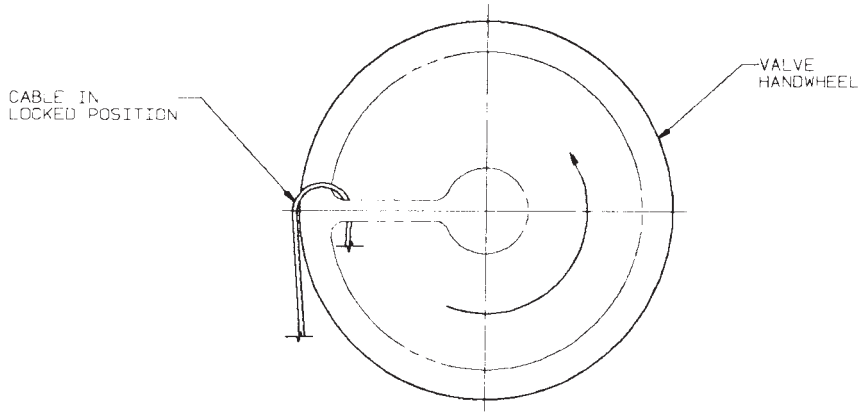

FIG. 1 Type I—Wire Rope Assembly



(a) Handwheel locked in maximum position clockwise rotation



(b) Handwheel locked in maximum position counterclockwise rotation

FIG. 2 Miscellaneous Type I Details

4.7.3 Type III:  
 4.7.3.1 Depth.  
 4.7.3.2 Height.  
 4.7.3.3 Width.

4.7.3.4 Outside diameter (OD) of pipe.

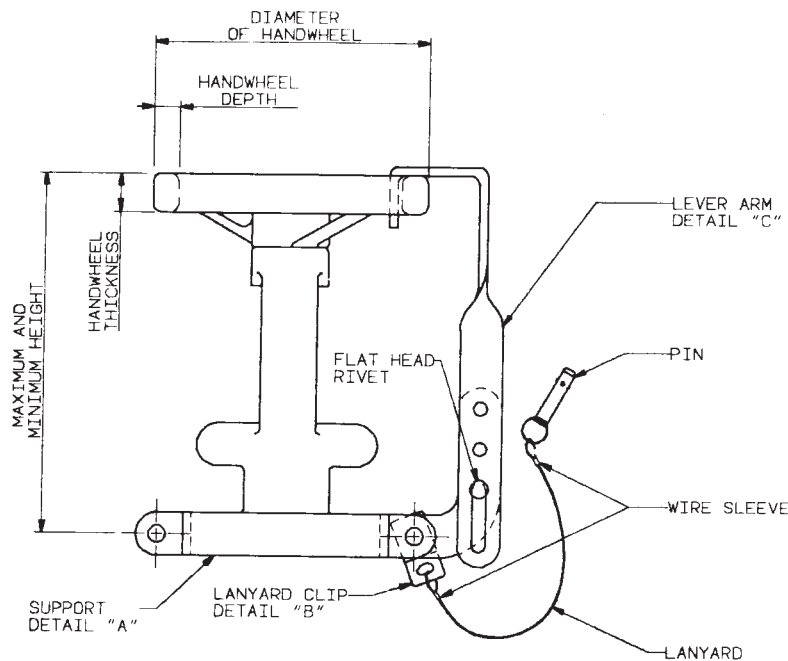

FIG. 3 Type II—Handwheel Latch

## 5. Materials and Manufacture

### 5.1 Materials:

#### 5.1.1 Type I Materials:

5.1.1.1 *Pipe Clamp*—Indicate diameter, similar to Practice F 708, Fig. 1, material specified by grade.

5.1.1.2 *Ring Link*—Size to be not less than clearance shown in Practice F 708, Table 3, Column F, material specified by grade.

5.1.1.3 *Common Wire Strand*— $\frac{3}{16}$ -in. diameter, seven strands of seven wires each, stainless steel, Specification A 492, Alloy 316.

5.1.1.4 *Tiller Rope Clamp*— $\frac{3}{16}$ -in. cable size, manufacturer, stainless steel (optional).

5.1.1.5 *Rigid Eye Spring Hook*— $\frac{5}{8}$ -in. eye diameter,  $\frac{1}{2}$ -in. snap opening, plated forged steel, Specification A 668/A 668M, Class D.

5.1.1.6 *Sleeve*—Swaging, oval, for  $\frac{3}{16}$ -in. diameter wire rope, copper.

#### 5.1.2 Type II Materials:

5.1.2.1 *Modified Pipe Clamp*—Indicate diameter, similar to Practice F 708, Fig. 1, material specified by grade.

5.1.2.2 *Flat Head Rivet*— $\frac{1}{4}$ -in. nominal size, ANSI B18.1, material specified by grade.

5.1.2.3 *Single Acting Quick Release Pin*— $\frac{1}{4}$ -in. nominal size by  $\frac{5}{10}$ -in. grip, stainless steel, Specification A 167, Type 316.

5.1.2.4 *Lanyard*—Wire rope,  $\frac{1}{8}$ -in. diameter, seven strands of seven wires each, 12 in. long, stainless steel Specification A 492, Alloy 316.

5.1.2.5 *Sleeve*—Swaging, oval, for  $\frac{1}{8}$ -in. diameter wire rope, copper.

5.1.2.6 *Lanyard Clip*—Flatbar,  $\frac{1}{16}$  in. thick by 1 in. wide by  $1\frac{1}{2}$  in. long, stainless steel, Specification A 167, Alloy 316.

5.1.2.7 *Lever Arm*—Size to suit, 16-gage material specified by grade.

#### 5.1.3 Type III Materials:

5.1.3.1 *Plate*—Indicate size, 16 gage, material specified by grade.

5.1.3.2 *Single-Acting Quick Release Pin*— $\frac{1}{4}$ -in. nominal size by  $\frac{1}{2}$ -in. grip, stainless steel, Specification A 167, Type 316.

5.1.3.3 *Lanyard*—Wire rope,  $\frac{1}{8}$ -in. diameter, seven strands of seven wires each, 12 in. long, stainless steel, Specification A 492, Alloy 316.

5.1.3.4 *Sleeve*—Swaging, oval, for  $\frac{1}{8}$ -in. diameter wire rope, copper.

5.1.3.5 *Lanyard Clip*—Flatbar,  $\frac{1}{16}$  in. thick by 1 in. wide by  $1\frac{1}{2}$  in. long, stainless steel, Specification A 167, Alloy 316.

5.1.3.6 *Lockbar*— $\frac{7}{8}$  in. wide by length to suit by  $\frac{1}{16}$  in. thick, material specified by grade.

#### 5.2 Manufacture:

5.2.1 Edges of the locking device shall be smooth. The devices shall also be free of defects and burrs.

5.2.2 Welds shall be done in accordance with American Welding Society D1.1.

## 6. General Requirements

6.1 A label plate shall be installed on or near the locking device to instruct the operator on usage.

6.2 When noise reduction is necessary, the contacting parts of the locking device shall have a rubber coating or lining.

6.3 The locking device must be able to lock the valve in both the fully opened and completely closed positions.

6.4 When using Type I, the cable shall be installed sufficiently tight to prevent more than slight movement of the handwheel in a direction opposite of the designed position but not so tight as to place the cable in tension.

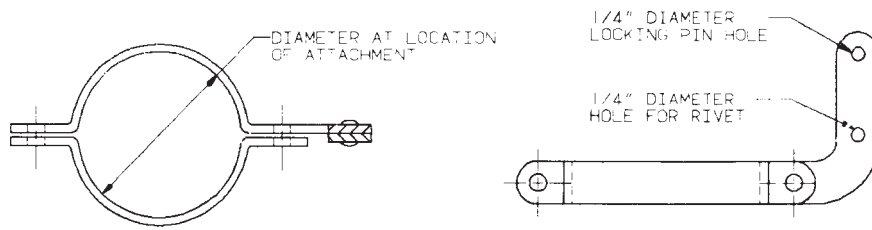

Support Detail "A"

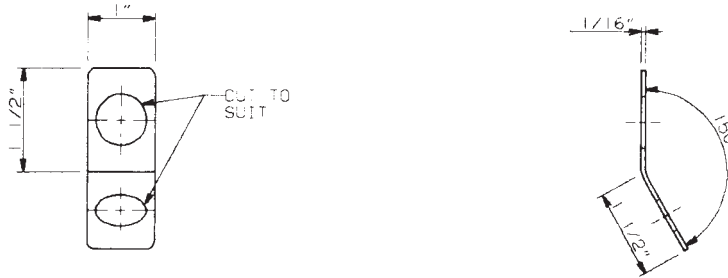

Lanyard Clip Detail "B"

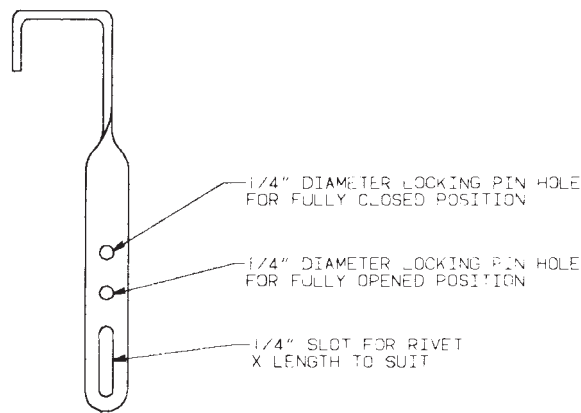

Lever Arm Detail "C"

**FIG. 4 Miscellaneous Type II Details**

6.5 The position of the locking device on the handwheel shall be as to resist movement of the valve stem.

6.6 Type II dimensions shall be used to determine the size of the lever arm, extension on pipe hanger, and the position of the locking holes and slot.

6.7 When specified by the purchaser, a padlock can be used instead of the quick release pin or spring hook.

**7. Dimensions and Tolerances**

7.1 Dimensions shall be as specified in the figures shown.

7.2 Tolerances are  $\pm 1/16$  in. except for drilled hole diameter for pin which shall be  $+1/32$  in.,  $-0$  in.

**8. Keywords**

8.1 locking device; marine technology; ship; valve; valve locking device

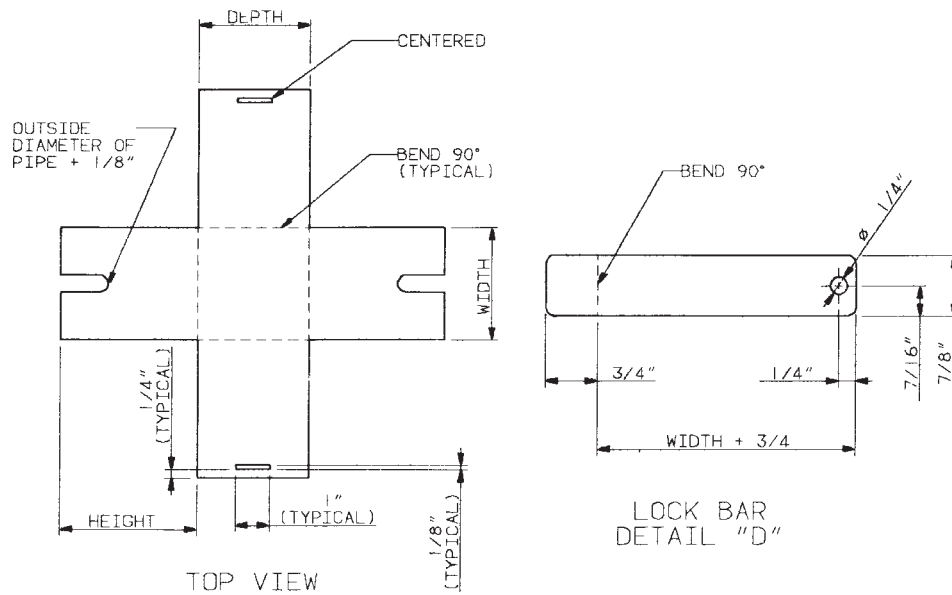
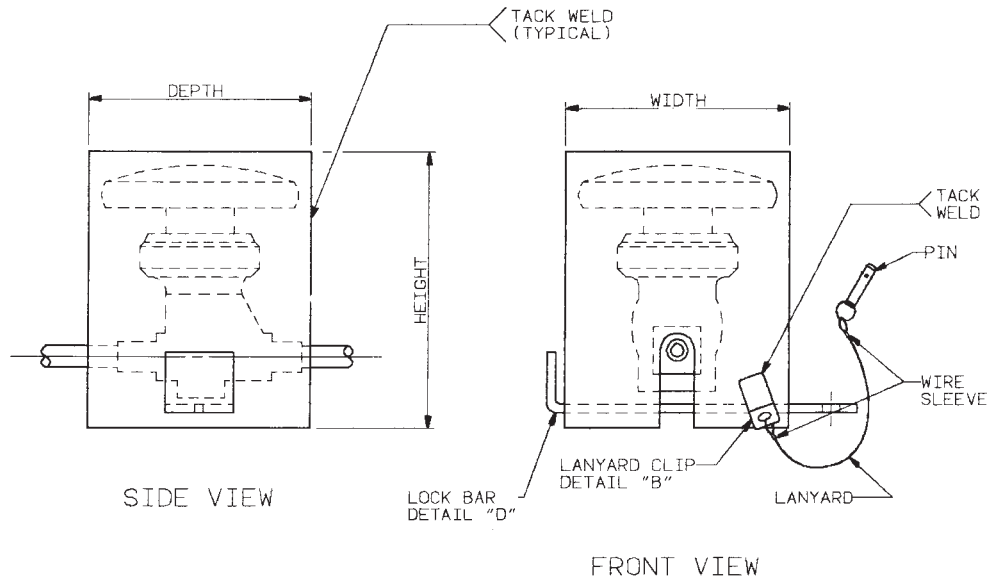

FIG. 5 Type III—Valve Cover Box



## **F 993 – 86 (2001)**

*ASTM International takes no position respecting the validity of any patent rights asserted in connection with any item mentioned in this standard. Users of this standard are expressly advised that determination of the validity of any such patent rights, and the risk of infringement of such rights, are entirely their own responsibility.*

*This standard is subject to revision at any time by the responsible technical committee and must be reviewed every five years and if not revised, either reapproved or withdrawn. Your comments are invited either for revision of this standard or for additional standards and should be addressed to ASTM International Headquarters. Your comments will receive careful consideration at a meeting of the responsible technical committee, which you may attend. If you feel that your comments have not received a fair hearing you should make your views known to the ASTM Committee on Standards, at the address shown below.*

*This standard is copyrighted by ASTM International, 100 Barr Harbor Drive, PO Box C700, West Conshohocken, PA 19428-2959, United States. Individual reprints (single or multiple copies) of this standard may be obtained by contacting ASTM at the above address or at 610-832-9585 (phone), 610-832-9555 (fax), or [service@astm.org](mailto:service@astm.org) (e-mail); or through the ASTM website ([www.astm.org](http://www.astm.org)).*