



Standard Specification for Driven Fasteners: Nails, Spikes, and Staples¹

This standard is issued under the fixed designation F 1667; the number immediately following the designation indicates the year of original adoption or, in the case of revision, the year of last revision. A number in parentheses indicates the year of last reapproval. A superscript epsilon (ϵ) indicates an editorial change since the last revision or reapproval.

This standard has been approved for use by agencies of the Department of Defense. The Commercial and Government Entity (Cage) Code for ASTM: 81346.

1. Scope

1.1 This specification covers nails, spikes, staples, and other driven fasteners, as listed in Table 1.

NOTE 1—Fastener ductility information is presented in Table 2 and dimensional information in Tables 3-64.

1.2 Fasteners described in this specification are driven by hand tool, power tool, or mechanical device in single or multiple strikes and may be positioned for striking by hand, tool, or machine.

1.3 The values stated in inch-pound units are to be regarded as the standard.

1.4 *This standard does not purport to address all of the safety concerns, if any, associated with its use. It is the responsibility of the user of this standard to establish appropriate safety and health practices and determine the applicability of regulatory limitations prior to use.*

2. Referenced Documents

2.1 ASTM Standards:

- A 153/A 153M Specification for Zinc Coating (Hot-Dip) on Iron and Steel Hardware²
- A 510 Specification for General Requirements for Wire Rods and Coarse Round Wire, Carbon Steel³
- A 641/A 641M Specification for Zinc-Coated (Galvanized) Carbon Steel Wire²
- B 695 Specification for Coatings of Zinc Mechanically Deposited on Iron and Steel⁴
- F 547 Terminology of Nails for Use with Wood and Wood-Base Materials⁵
- F 592 Terminology of Collated and Cohered Fasteners and Their Application Tools⁵
- F 680 Test Methods for Nails⁵
- F 1575 Test Method for Determining Bending Yield Moment of Nails⁵

¹ This specification is under the jurisdiction of ASTM Committee F16 on Fasteners and is the direct responsibility of Subcommittee F16.05 on Driven and Other Fasteners.

Current edition approved July 10, 2000. Published September 2000. Originally published as F 1667-95. Last previous edition F 1667-97.

² Annual Book of ASTM Standards, Vol 01.06.

³ Annual Book of ASTM Standards, Vol 01.03.

⁴ Annual Book of ASTM Standards, Vol 02.05.

⁵ Annual Book of ASTM Standards, Vol 01.08.

3. Terminology

3.1 *Definitions*—The definitions used in this specification are those of common commercial acceptance and usage and also appear in Terminologies F 547 and F 592.

4. Classification

4.1 The fasteners and their Table 1 classification are identified as follows:

NOTE 2—The identification of fasteners, classified by style and type (alpha indicators) followed by a dash number (numerical code) based on Tables 3-64, identifies dimensions specifically and establishes a PIN (part identifying number) system when preceded by the F 1667 ASTM designator of this specification. For example:

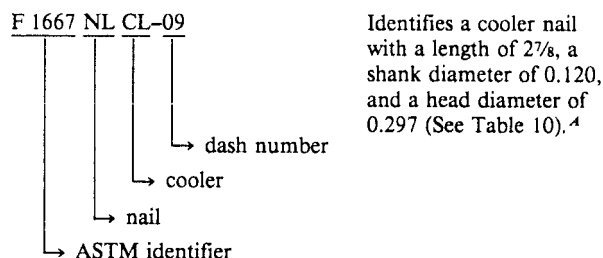

⁴ All dimensions are given in inches.

4.2 The trade designation, S, pennyweight, used in commercial practice is referenced in Tables 3-64 wherever it applies.

5. Ordering Information

5.1 Orders for driven fasteners under this specification shall include the following information:

- 5.1.1 Quantity or weight;
- 5.1.2 Part identifying number (PIN) or product description (see 4.1 and appropriate table);
- 5.1.3 Special material requirements, if specified, including coatings or finishes;
- 5.1.4 ASTM designation;
- 5.1.5 Packaging requirements;
- 5.1.6 A producer's or supplier's certification that the material and the finished fastener are in compliance with this specification, furnished only when specified in the purchase order;
- 5.1.7 Supplementary requirements, if any; and

TABLE 1 Classification and Identification Index

| Type | Style | Style Identification | Table | |
|-------------------|-------------------------|----------------------|-------|----|
| I—Nails (NL) | 1. Brads | BR | 3 | |
| | 2. Barrel | BL | 4 | |
| | 3. Boat | BTH/BTL | 5 | |
| | 4. Box A | BXA | 6 | |
| | | Box B | BXB | 7 |
| | 5. Broom | BM | 8 | |
| | 6. Casing | CN | 9 | |
| | 7. Cooler | CL | 10 | |
| | 8. Sinkers | SK | 11 | |
| | 9. Corker | CK | 12 | |
| | 10. Common | CMA | 13 | |
| | | Common | CMC | 14 |
| | | Common | CMS | 15 |
| | | Common | CMM | 16 |
| | 11. Concrete | CTS/CTM | 17 | |
| | 12. Double-headed | DH | 18 | |
| | 13. Fine | FN | 19 | |
| | 14. Finishing | FH | 20 | |
| | 15. Flooring | FL | 21 | |
| | 16. Lath | LHF | 22 | |
| | | Lath | LHH | 23 |
| | 17. Masonry | MR/MRH | 24 | |
| | 18. Pallet | PL | 25 | |
| | 19. Gypsum wallboard | GWS | 26 | |
| | | Gypsum wallboard | GWM | 27 |
| | 20. Roofing | RFA | 28 | |
| | | Roofing | RFS | 29 |
| | | Roofing | RFC | 30 |
| | | Roofing | RFL | 31 |
| | Roofing | RFR | 32 | |
| | Roofing | RFD | 33 | |
| | Roofing | RFZB/RFZR | 34 | |
| | Roofing | RFNS/RFND | 35 | |
| 21. Shingle | SHAD/SHAS | 36 | | |
| | Shingle | SHSS/SHNSB | 37 | |
| 22. Siding | SDF/SDC/SDK | 38 | | |
| 23. Slating | SLA/SLC/SLS | 39 | | |
| 24. Rubber heel | RH | 40 | | |
| 25. Underlayment | UL | 41 | | |
| 26. Square-barbed | SB | 42 | | |
| 27. Masonry drive | MD | 43 | | |
| 28. Escutcheon | ES | 44 | | |
| 29. Glulam rivet | GR | 45 | | |
| II—Cut nails (CN) | 1. Common | CM | 46 | |
| | 2. Basket | BK | 47 | |
| | 3. Clout | CL | 48 | |
| | 4. Trunk | TR | 49 | |
| | 5. Cobblers | CB | 50 | |
| | 6. Extra-iron clinching | EC | 51 | |
| | 7. Hob | HB | 52 | |
| III—Spikes (SP) | 1. Common | CM | 53 | |
| | 2. Gutter | GRF/GRO | 54 | |
| | 3. Round | RDC/RDF | 55 | |
| | 4. Barge and boat | BB | 56 | |
| IV—Staples (ST) | 1. Fence | FN | 57 | |
| | 2. Poultry netting | PN | 58 | |
| | 3. Flat top crown | FC | 59 | |
| | | Flat top crown | FCC | 60 |
| | 4. Round or V crown | RC | 61 | |
| | 5. Preformed | PC | 62 | |
| | 6. Electrical | RE | 63 | |
| | Preformed hoop | PH | 64 | |

5.1.8 Any additions agreed upon between the purchaser and the supplier.

6. Material Requirements

6.1 Steel wire used in the manufacture of driven fasteners shall be of low-carbon, medium-low carbon, or medium-high carbon.

TABLE 2 Bend Angles for Fasteners Using the Test Methods F 680 Bend Test

| Fastener Material | Bend Angle, ° |
|--|---------------|
| 1. Steel wire: (low-carbon, medium-low carbon, medium-carbon) (unhardened) | 180 |
| 2. Stainless steel wire | 180 |
| 3. Hardened steel fasteners | 20 |
| 4. Sheet steel for cut nails, Type II, and cut spikes, Type III | 90 |
| 5. Copper (min 98 %) | 180 |
| 6. Copper clad wire (min 20 %) | 180 |
| 7. Aluminum alloy wire | 90 |
| 8. Brass wire | 180 |

6.2 Stainless steel wire used in the manufacture of driven fasteners shall be of Types 302, 304, 305, or 316.

6.3 Carbon steel wire for the manufacture of hardened steel nails shall be suitable for heat treatment to a minimum hardness of 37 HRC.

6.4 Sheet steel used in the manufacture of cut nails (Type II) and cut spikes (Type III) shall be a medium-carbon sheet steel.

6.5 Copper used in the manufacture of driven fasteners shall contain a minimum of 98 % pure copper.

6.6 Copper-clad steel wire used in the manufacture of driven fasteners shall contain not less than 20 % copper by weight. The average thickness of copper on the steel wire shall be not less than 10 % of the radius of the clad wire; the minimum thickness of copper on the steel wire shall be not less than 8 % of the radius of the clad wire.

6.7 Aluminum alloy wire used in the manufacture of fasteners shall conform to Alloy 2024, 5056, 6061, or 6110 and have a minimum ultimate tensile strength of 60 000 psi. Smooth shank nails may be chemically treated to remove all grease, oil, and foreign matter and to roughen the surface microscopically. Mechanically deformed nails may be cleaned to remove all grease and foreign matter.

6.8 Brass wire used in the manufacture of fasteners shall be of good commercial quality suitable for the purpose.

7. Physical Properties

7.1 *Ductility*—The fasteners shall be sufficiently ductile to withstand cold bending without fracture, as specified in Table 2 for various materials used in the manufacture of fasteners utilizing the conventional bend test described in Test Methods F 680. The cold bend test shall not apply to unhardened nails with deformed shanks.

7.2 *Tensile Strength*—Finished driven fasteners are not normally subject to tension testing. However, the wire or sheet used to manufacture the fastener is tested as required for control in the production process during manufacture.

8. Dimensions and Tolerances

8.1 Nominal dimensions of nails and spikes shall be as shown in Tables 3-56. The following dimensional designations shall apply:

TABLE 3 Type I, Style 1—Brads^A

NOTE—Steel wire, brad head, diamond point, round smooth shank, bright finish. When specified, brads shall have a modified brad head with a blunt or chiseled point for use with mechanical drivers.

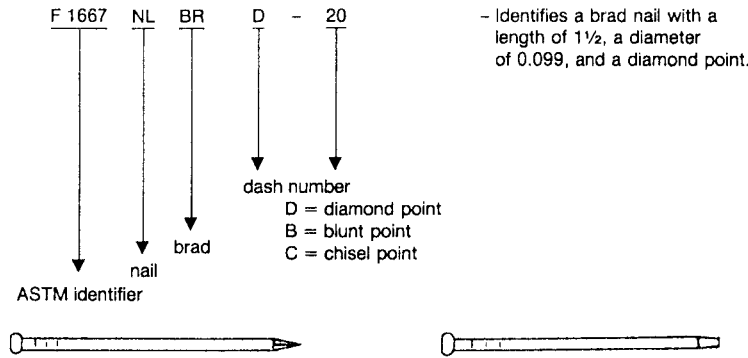

| Dash No. | L | D | S | No./lb | Dash No. | L | D | S | No./lb |
|----------|-------|-------|-----|--------|----------|-------|-------|-----|--------|
| 01 | 3/8 | 0.035 | ... | 9520 | 21 | 1 3/4 | 0.062 | ... | 670 |
| 02 | 1/2 | 0.035 | ... | 7060 | 22 | 1 3/4 | 0.080 | ... | 400 |
| 03 | 1/2 | 0.048 | ... | 3990 | 23 | 1 3/4 | 0.099 | 5d | 270 |
| 04 | 5/8 | 0.035 | ... | 5680 | 24 | 2 | 0.062 | ... | 580 |
| 05 | 5/8 | 0.048 | ... | 3200 | 25 | 2 | 0.080 | ... | 350 |
| 06 | 3/4 | 0.035 | ... | 4800 | 26 | 2 | 0.113 | 6d | 180 |
| 07 | 3/4 | 0.048 | ... | 2620 | 27 | 2 1/4 | 0.080 | ... | 320 |
| 08 | 3/4 | 0.062 | ... | 1550 | 28 | 2 1/4 | 0.113 | 7d | 160 |
| 09 | 7/8 | 0.035 | ... | 4220 | 29 | 2 1/2 | 0.080 | ... | 290 |
| 10 | 7/8 | 0.048 | ... | 2220 | 30 | 2 1/2 | 0.131 | 8d | 110 |
| 11 | 7/8 | 0.062 | ... | 1280 | 31 | 2 3/4 | 0.131 | 9d | 97 |
| 12 | 1 | 0.054 | ... | 1500 | 32 | 3 | 0.148 | 10d | 70 |
| 13 | 1 | 0.062 | ... | 1120 | 33 | 3 1/4 | 0.148 | 12d | 65 |
| 14 | 1 | 0.072 | ... | 904 | 34 | 3 1/2 | 0.162 | 16d | 50 |
| 15 | 1 1/4 | 0.054 | ... | 1210 | 35 | 4 | 0.192 | 20d | 31 |
| 16 | 1 1/4 | 0.062 | ... | 940 | 36 | 4 1/2 | 0.207 | 30d | 24 |
| 17 | 1 1/4 | 0.080 | 3d | 560 | 37 | 5 | 0.225 | 40d | 18 |
| 18 | 1 1/2 | 0.054 | ... | 1040 | 38 | 5 1/2 | 0.244 | 50d | 14 |
| 19 | 1 1/2 | 0.080 | ... | 470 | 39 | 6 | 0.262 | 60d | 11 |
| 20 | 1 1/2 | 0.099 | 4d | 320 | ... | ... | ... | ... | ... |

^A All dimensions are given in inches.

- S = trade designation (reference in penny weight),
- L = length, in.,
- H = head diameter or width, in.,
- D = shank diameter, in.,
- B = head separation, in. (Table 18), and
- No./lb = approximate count per pound.

8.1.1 The lengths, *L*, of nails and spikes with flat heads or parallel shoulders under the head shall be measured from under the head or shoulder to the tip of the point. All other nails and spikes shall be measured overall.

8.1.2 The diameter, *D*, of smooth shank nails and spikes shall be measured away from the gripper marks. The diameter, *D*, of formed or deformed shanks shall be measured before deformation, or, if specified, the thread crest diameter after deformation, or both. All diameter dimensions shall be taken prior to the application of or after the removal of any coatings or finish.

8.2 Tolerances on Nominal Dimensions for Nails and Spikes:

8.2.1 Length tolerances shall be ±1/32 in. for lengths up to and including 1 in.; ±1/16 in. for lengths over 1 in., up to and including 2 1/2 in.; ±3/32 for lengths over 2 1/2 in., up to and including 7 in.; and ±1/8 in. for all lengths over 7 in.

8.2.2 Shank diameter tolerances shall be ±0.002 in. for diameters smaller than 0.076 in. and ±0.004 in. for diameters 0.076 in. and larger.

8.2.3 Head Diameter Tolerances:

8.2.3.1 Hand Driven—Tolerances on head diameters of roofing nails shall be +0, -10 % of the nominal head diameter (the mean of two readings 90° apart). For other brads, nails, and spikes, the tolerance shall be ±10 % of the nominal head diameter (individual measurement). The difference in diameter across the long axis of a roofing nail shall not exceed that across the short axis by more than 20 %. For other brads, nails, and spikes, the difference in diameter across the long axis shall not exceed that across the short axis by more than 10 %. A fillet shall be provided under the head if not otherwise specified.

8.2.3.2 Power Driven—Tolerances on head diameters of power-driven nails shall comply with the manufacturer's specifications and shall be suitable for use in the make and model of the tool specified.

8.3 Nominal dimensions of staples shall be as shown in Tables 57-64, and the following dimensional designations shall apply:

8.3.1 Hand Tool-Driven Nominal Dimensions:

ASTM F 1667

TABLE 4 Type I, Style 2—Barrel Nails^A

NOTE—Steel wire, flat head, diamond point, round smooth shank, bright, zinc or cement coated as specified.

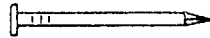
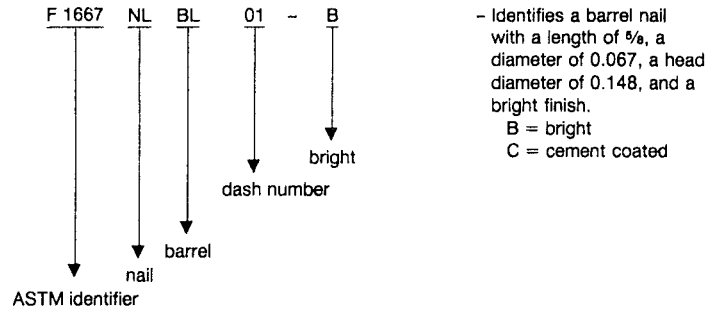

| Dash No. | L | D | H | No./lb | Dash No. | L | D | H | No./lb |
|----------|---------------|-------|-------|--------|----------|----------------|-------|-------|--------|
| 01 | $\frac{5}{8}$ | 0.067 | 0.148 | 1.550 | 05 | $1\frac{1}{8}$ | 0.076 | 0.177 | 670 |
| 02 | $\frac{3}{4}$ | 0.067 | 0.148 | 1.300 | 06 | $1\frac{1}{4}$ | 0.080 | 0.188 | 540 |
| 03 | $\frac{7}{8}$ | 0.076 | 0.177 | 850 | 07 | $1\frac{3}{8}$ | 0.092 | 0.219 | 380 |
| 04 | 1 | 0.076 | 0.177 | 750 | 08 | $1\frac{1}{2}$ | 0.092 | 0.219 | 350 |

^A All dimensions are given in inches.

TABLE 5 Type I, Style 3—Boat nails^A

NOTE—Steel wire, oval countersunk head, chisel point, round smooth shank, bright or zinc coated as specified.

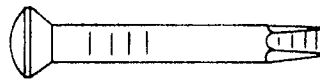
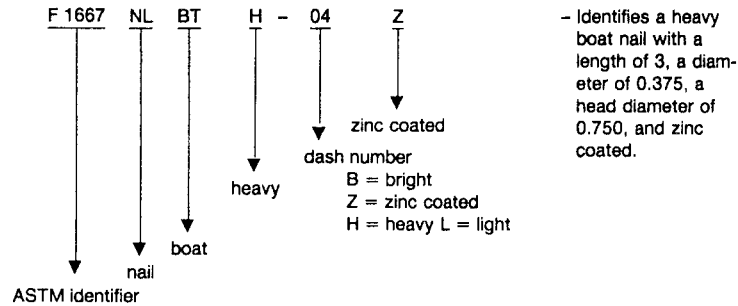

| F 1667 NLBTL | | | | | | F 1667 NLBTH | | | | | |
|--------------|-----|----------------|-------|-------|--------|--------------|-----|----------------|-------|-------|--------|
| Dash No. | S | L | D | H | No./lb | Dash No. | S | L | D | H | No./lb |
| 01 | 4d | $1\frac{1}{2}$ | 0.188 | 0.406 | 82 | 01 | 4d | $1\frac{1}{2}$ | 0.250 | 0.500 | 47 |
| 02 | 6d | 2 | 0.188 | 0.406 | 62 | 02 | 6d | 2 | 0.250 | 0.500 | 36 |
| 03 | 8d | $2\frac{1}{2}$ | 0.188 | 0.406 | 50 | 03 | 8d | $2\frac{1}{2}$ | 0.250 | 0.500 | 29 |
| 04 | 10d | 3 | 0.250 | 0.500 | 24 | 04 | 10d | 3 | 0.375 | 0.750 | 11 |
| 05 | 12d | $3\frac{1}{4}$ | 0.250 | 0.500 | 22 | 05 | 12d | $3\frac{1}{4}$ | 0.375 | 0.750 | 10 |
| 06 | 16d | $3\frac{1}{2}$ | 0.250 | 0.500 | 20 | 06 | 16d | $3\frac{1}{2}$ | 0.375 | 0.750 | 9 |
| 07 | 20d | 4 | 0.250 | 0.500 | 18 | 07 | 20d | 4 | 0.375 | 0.750 | 8 |

^A All dimensions are given in inches.

- L = leg length, inside, in.,
- D = round leg diameter, in.,
- C = crown width, inside, in., and
- No./lb = approximate count per pound.

8.3.2 Power Tool-Driven Nominal Dimensions:

F 1667

TABLE 6 Type I, Style 4A—Box Nails^A

NOTE—Steel wire, flat head, diamond point, round, barbed or smooth shank, bright or cement coated as specified. When specified, box nails shall have an altered or T-head with a diamond, blunt, or chisel point for use with mechanical drivers.

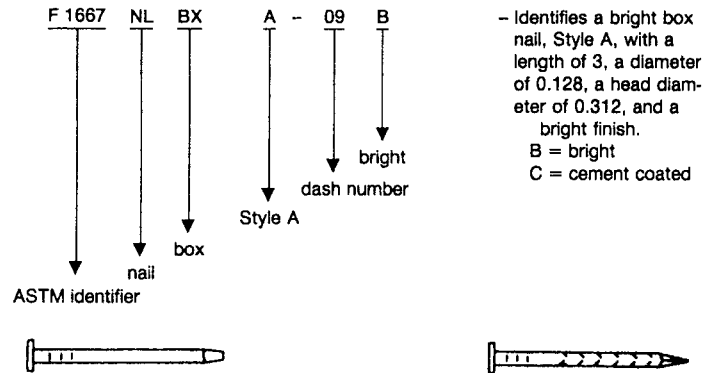

| F 1667 NLBXA | | | | | | | | | | | |
|--------------|----|-------------------------------|-------|-------|--------|----------|-----|-------------------------------|-------|-------|--------|
| Dash No. | S | L | D | H | No./lb | Dash No. | S | L | D | H | No./lb |
| 01 | 2d | 1 | 0.067 | 0.188 | 940 | 08 | 9d | 2 ³ / ₄ | 0.113 | 0.297 | 120 |
| 02 | 3d | 1 ¹ / ₄ | 0.076 | 0.219 | 590 | 09 | 10d | 3 | 0.128 | 0.312 | 90 |
| 03 | 4d | 1 ¹ / ₂ | 0.080 | 0.219 | 450 | 10 | 12d | 3 ¹ / ₄ | 0.128 | 0.312 | 83 |
| 04 | 5d | 1 ³ / ₄ | 0.080 | 0.219 | 390 | 11 | 16d | 3 ¹ / ₂ | 0.135 | 0.344 | 69 |
| 05 | 6d | 2 | 0.099 | 0.266 | 220 | 12 | 20d | 4 | 0.148 | 0.375 | 50 |
| 06 | 7d | 2 ¹ / ₄ | 0.099 | 0.266 | 200 | 13 | 30d | 4 ¹ / ₂ | 0.148 | 0.375 | 45 |
| 07 | 8d | 2 ¹ / ₂ | 0.113 | 0.297 | 140 | 14 | 40d | 5 | 0.162 | 0.406 | 34 |

^A All dimensions are given in inches.

TABLE 7 Type I, Style 4B—Box Nails^A

NOTE—Steel wire, flat head, diamond point, round smooth shank, cement coated.

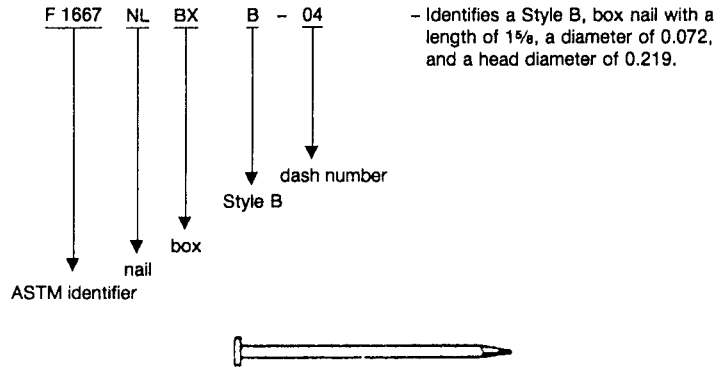

| F 1667 NLBXB | | | | | | | | | | | |
|--------------|----|-------------------------------|-------|-------|--------|----------|-----|-------------------------------|-------|-------|--------|
| Dash No. | S | L | D | H | No./lb | Dash No. | S | L | D | H | No./lb |
| 01 | 2d | 1 | 0.058 | 0.172 | 1250 | 06 | 7d | 2 ¹ / ₈ | 0.086 | 0.250 | 280 |
| 02 | 3d | 1 ¹ / ₈ | 0.062 | 0.188 | 980 | 07 | 8d | 2 ³ / ₈ | 0.099 | 0.266 | 190 |
| 03 | 4d | 1 ³ / ₈ | 0.067 | 0.203 | 680 | 08 | 9d | 2 ⁵ / ₈ | 0.099 | 0.266 | 170 |
| 04 | 5d | 1 ⁵ / ₈ | 0.072 | 0.219 | 510 | 09 | 10d | 2 ⁷ / ₈ | 0.113 | 0.297 | 120 |
| 05 | 6d | 1 ⁷ / ₈ | 0.086 | 0.250 | 315 | ... | ... | ... | ... | ... | ... |

^A All dimensions are given in inches.

- D* = round leg diameter, in.,
- L* = leg length, outside, in.,
- T* = leg thickness, in. (see Table 58),
- W* = leg width, in. (see Table 58),
- C* = crown width, outside, in., and
- G* = steel wire gage.

- 8.4 Tolerances on Nominal Dimensions for Staples:
- 8.4.1 Leg length, *L*, tolerances shall be +¹/₃₂, -¹/₆₄in. for both hand tool-driven and power tool-driven staples.
 - 8.4.2 Diameter tolerances for hand tool-driven round staples shall be ±0.002 in. for diameters smaller than 0.076 in. and ±0.004 in. for diameters 0.076 in. and larger.
 - 8.4.3 Thickness and width tolerances on power-driven

ASTM F 1667

TABLE 8 Type I, Style 5—Broom Nails^A

NOTE—Steel wire, flat or star head, diamond point, round smooth shank, bright finish, as specified.

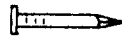
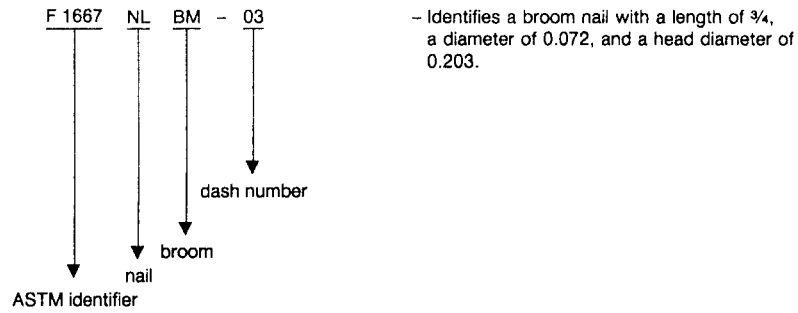

| Dash No. | L | D | H | No./lb |
|----------|-----|-------|-------|--------|
| 01 | 5/8 | 0.072 | 0.203 | 1480 |
| 02 | 5/8 | 0.080 | 0.219 | 990 |
| 03 | 3/4 | 0.072 | 0.203 | 1170 |
| 04 | 3/4 | 0.080 | 0.219 | 840 |

^A All dimensions are given in inches.

TABLE 9 Type I, Style 6—Casing Nails^A

NOTE—Steel wire, flat countersunk cupped head, diamond point, round smooth shank, bright finish.

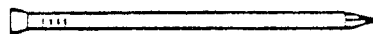
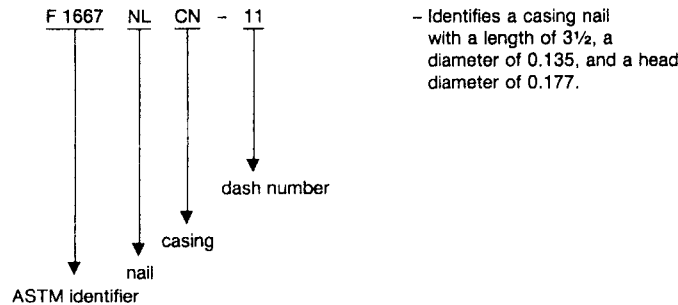

| Dash No. | S | L | D | H | No./lb | Dash No. | S | L | D | H | No./lb |
|----------|----|-------|-------|-------|--------|----------|-----|-------|-------|-------|--------|
| 01 | 2d | 1 | 0.067 | 0.099 | 1090 | 07 | 8d | 2 1/2 | 0.113 | 0.155 | 150 |
| 02 | 3d | 1 1/4 | 0.076 | 0.113 | 650 | 08 | 9d | 2 3/4 | 0.113 | 0.155 | 135 |
| 03 | 4d | 1 1/2 | 0.080 | 0.120 | 490 | 09 | 10d | 3 | 0.128 | 0.170 | 95 |
| 04 | 5d | 1 3/4 | 0.080 | 0.120 | 415 | 10 | 12d | 3 1/4 | 0.128 | 0.170 | 90 |
| 05 | 6d | 2 | 0.099 | 0.142 | 245 | 11 | 16d | 3 1/2 | 0.135 | 0.177 | 75 |
| 06 | 7d | 2 1/4 | 0.099 | 0.142 | 215 | ... | ... | ... | ... | ... | ... |

^A All dimensions are given in inches.

staples shall comply with the manufacturer's specification and shall be suitable for use in the make and model tool specified (see Tables 56-63).

8.4.4 Crown width tolerances are $\pm 1/32$ in. unless otherwise specified.

8.5 *Nominal Dimensions for Cut Nails, Type II*—Unless otherwise specified, cut nails shall be sheared from medium carbon sheet steel and shall have a wedge-shaped shank with a sheared square point end narrower than the upset head end. The designation *T* in Tables 46-51 refers to sheet thickness in finished product. Other designations shall be the same as those for nails in 8.1.

8.6 When gage is used for a nominal diameter dimension in the application of this specification, it shall be in accordance with the decimal equivalents as shown in Specification A 510, unless otherwise specified.

9. Workmanship

9.1 Fasteners covered by this specification shall be true to shape, well-finished, free from imperfections, clean, and free of corrosion. Mechanically driven collated items shall be uniform and aligned properly in their assembled form for use in power tools.

F 1667

TABLE 10 Type I, Style 7—Cooler Nails^A

NOTE—Steel wire, flat head, diamond point, round smooth shank, cement coated. When specified, coolers shall have an altered or T-head for use with mechanical drivers.

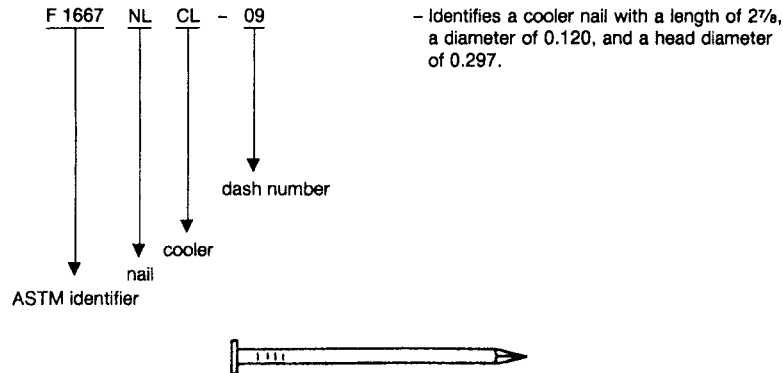

| Dash No. | S | L | D | H | No./lb | Dash No. | S | L | D | H | No./lb |
|----------|----|-------------------------------|-------|-------|--------|----------|-----|-------------------------------|-------|-------|--------|
| 01 | 2d | 1 | 0.062 | 0.172 | 1110 | 06 | 7d | 2 ¹ / ₈ | 0.099 | 0.266 | 210 |
| 02 | 3d | 1 ¹ / ₈ | 0.067 | 0.188 | 840 | 07 | 8d | 2 ³ / ₈ | 0.113 | 0.281 | 140 |
| 03 | 4d | 1 ³ / ₈ | 0.080 | 0.219 | 490 | 08 | 9d | 2 ⁵ / ₈ | 0.113 | 0.281 | 130 |
| 04 | 5d | 1 ⁵ / ₈ | 0.086 | 0.234 | 370 | 09 | 10d | 2 ⁷ / ₈ | 0.120 | 0.297 | 100 |
| 05 | 6d | 1 ⁷ / ₈ | 0.092 | 0.250 | 280 | ... | ... | ... | ... | ... | ... |

^A All dimensions are given in inches.

TABLE 11 Type I, Style 8—Sinker Nails^A

NOTE—Steel wire, flat countersunk head, diamond point, round smooth shank, bright or cement coated. When specified, sinkers shall have an altered or T-head for use with mechanical drivers.

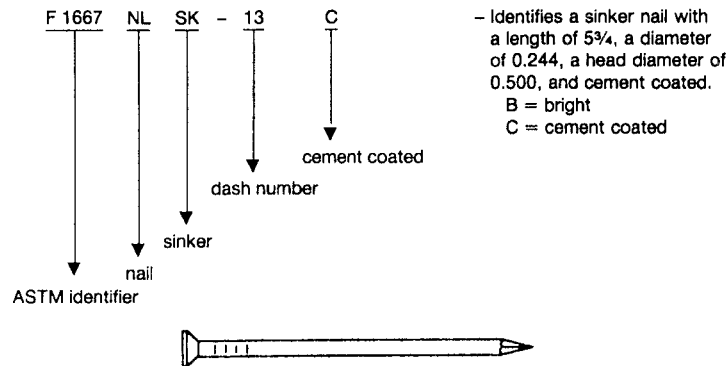

| Dash No. | S | L | D | H | No./lb | Dash No. | S | L | D | H | No./lb |
|----------|-----|-------------------------------|-------|-------|--------|----------|-----|-------------------------------|-------|-------|--------|
| 01 | 3d | 1 ¹ / ₈ | 0.067 | 0.172 | 940 | 08 | 12d | 3 ¹ / ₈ | 0.135 | 0.312 | 81 |
| 02 | 4d | 1 ³ / ₈ | 0.080 | 0.203 | 530 | 09 | 16d | 3 ¹ / ₄ | 0.148 | 0.344 | 64 |
| 03 | 5d | 1 ⁵ / ₈ | 0.086 | 0.219 | 390 | 10 | 20d | 3 ³ / ₄ | 0.177 | 0.375 | 40 |
| 04 | 6d | 1 ⁷ / ₈ | 0.092 | 0.234 | 290 | 11 | 30d | 4 ¹ / ₄ | 0.192 | 0.406 | 30 |
| 05 | 7d | 2 ¹ / ₈ | 0.099 | 0.250 | 220 | 12 | 40d | 4 ³ / ₄ | 0.207 | 0.438 | 23 |
| 06 | 8d | 2 ³ / ₈ | 0.113 | 0.266 | 150 | 13 | 60d | 5 ³ / ₄ | 0.244 | 0.500 | 14 |
| 07 | 10d | 2 ⁷ / ₈ | 0.120 | 0.281 | 110 | ... | ... | ... | ... | ... | ... |

^A All dimensions are given in inches.

10. Protective Coatings and Finishes

10.1 Zinc Coating:

10.1.1 Driven fasteners required to be zinc coated shall be cut and formed from hot-dip, hard-wiped, galvanized steel wire, electrogalvanized steel wire, or zinc flake/chromate dispersion-coated steel wire; or they shall be cut from uncoated (bright) steel wire and shall be hot-dip galvanized, electrode-

posited zinc coated, mechanically deposited zinc coated, or zinc flake/chromate dispersion coated after forming. Power-driven staples are not normally zinc coated after forming.

10.1.2 Hot-dip galvanized or electrogalvanized steel wire for the manufacture of fasteners shall have a coating weight in accordance with Specification A 641, Supplementary Requirements, Class 1.

TABLE 12 Type I, Style 9—Corker Nails^A

NOTE—Steel wire, flat countersunk head, diamond point, round smooth shank, cement coated. When specified, corkers shall have an altered or T-head for use with mechanical drivers.

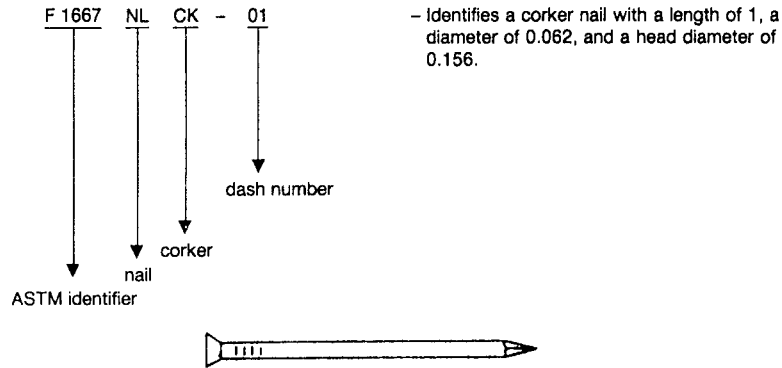

| Dash No. | S | L | D | H | No./lb | Dash No. | S | L | D | H | No./lb |
|----------|----|-------------------------------|-------|-------|--------|----------|-----|-------------------------------|-------|-------|--------|
| 01 | 2d | 1 | 0.062 | 0.156 | 1220 | 09 | 10d | 2 ⁷ / ₈ | 0.135 | 0.312 | 89 |
| 02 | 3d | 1 ¹ / ₄ | 0.072 | 0.188 | 720 | 10 | 12d | 3 ¹ / ₈ | 0.135 | 0.312 | 81 |
| 03 | 4d | 1 ¹ / ₂ | 0.086 | 0.219 | 420 | 11 | 16d | 3 ³ / ₈ | 0.148 | 0.344 | 62 |
| 04 | 5d | 1 ⁵ / ₈ | 0.086 | 0.219 | 320 | 12 | 20d | 3 ⁷ / ₈ | 0.177 | 0.375 | 38 |
| 05 | 6d | 1 ⁷ / ₈ | 0.099 | 0.250 | 250 | 13 | 30d | 4 ³ / ₈ | 0.192 | 0.406 | 29 |
| 06 | 7d | 2 ¹ / ₈ | 0.099 | 0.250 | 220 | 14 | 40d | 4 ⁷ / ₈ | 0.207 | 0.438 | 22 |
| 07 | 8d | 2 ³ / ₈ | 0.120 | 0.281 | 130 | 15 | 50d | 5 ³ / ₈ | 0.226 | 0.469 | 17 |
| 08 | 9d | 2 ⁵ / ₈ | 0.120 | 0.281 | 120 | 16 | 60d | 5 ⁷ / ₈ | 0.244 | 0.500 | 13 |

^A All dimensions are given in inches.

TABLE 13 Type I, Style 10—Common Nails^A

NOTE—Aluminum alloy wire, flat head, diamond point, round smooth shank, or, when specified, square barbed shank.

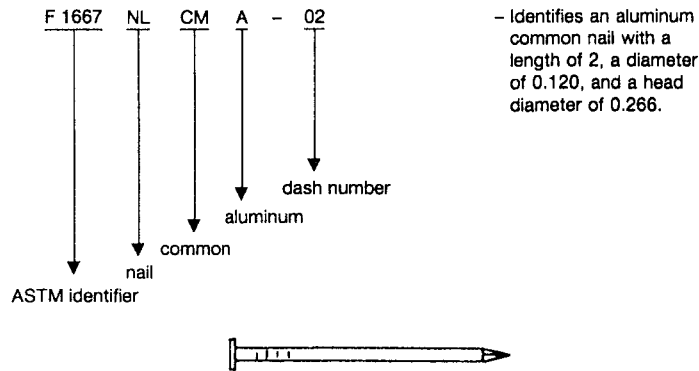

| F 1667 NLCMA | | | | | | | | | | | |
|--------------|----|-------------------------------|-------|-------|--------|----------|-----|-------------------------------|-------|-------|--------|
| Dash No. | S | L | D | H | No./lb | Dash No. | S | L | D | H | No./lb |
| 01 | 4d | 1 ¹ / ₂ | 0.099 | 0.250 | 830 | 04 | 10d | 3 | 0.162 | 0.312 | 170 |
| 02 | 6d | 2 | 0.120 | 0.266 | 430 | 05 | 16d | 3 ¹ / ₂ | 0.177 | 0.344 | 120 |
| 03 | 8d | 2 ¹ / ₂ | 0.148 | 0.281 | 220 | 06 | 20d | 4 | 0.199 | 0.406 | 78 |

^A All dimensions are given in inches.

10.1.3 Hot-dip galvanized steel fasteners coated after forming shall have a coating weight in accordance with Specification A 153, Class D, when a heavier coating for exterior use is specified. If not otherwise specified, the coating weight shall be in accordance with Specification A 641, Supplementary Requirements, Class 1.

10.1.4 Mechanically deposited zinc coatings applied to fasteners after forming shall have a thickness in accordance with Specification B 695, Class 40, unless otherwise specified.

10.2 Other Coatings and Finishes (When Specified):

10.2.1 Cement coating shall be applied by tumbling, mechanical dispensing device, or immersion in resin or other similar material and shall not be tacky or gummy. Cement coatings on power-driven fasteners shall be uniform and may be applied before, during, or after the fasteners are cohered into strips, clips, or coils.

NOTE 3—Cement coatings increase the holding strength in withdrawal

F 1667

TABLE 14 Type I, Style 10—Common Nails^A

NOTE—Copper wire, flat head, diamond point, round smooth shank.

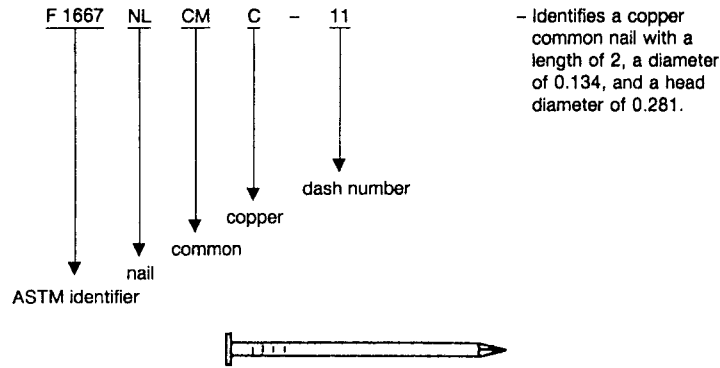

| F 1667 NLCMC | | | | | | | | | |
|--------------|-------|-------|-------|--------|----------|-------|-------|-------|--------|
| Dash No. | L | D | H | No./lb | Dash No. | L | D | H | No./lb |
| 01 | 5/8 | 0.065 | 0.156 | 1380 | 10 | 2 | 0.120 | 0.266 | 130 |
| 02 | 3/4 | 0.065 | 0.156 | 1160 | 11 | 2 | 0.134 | 0.281 | ... |
| 03 | 3/4 | 0.072 | 0.172 | 960 | 12 | 2 1/2 | 0.134 | 0.281 | 86 |
| 04 | 7/8 | 0.072 | 0.172 | 810 | 13 | 3 | 0.148 | 0.312 | 56 |
| 05 | 1 | 0.072 | 0.172 | 700 | 14 | 3 1/2 | 0.165 | 0.344 | 40 |
| 06 | 1 1/4 | 0.083 | 0.203 | 420 | 15 | 4 | 0.203 | 0.406 | 23 |
| 07 | 1 1/2 | 0.109 | 0.250 | 210 | 16 | 4 1/2 | 0.220 | 0.438 | 18 |
| 08 | 1 3/4 | 0.109 | 0.250 | 180 | 17 | 5 | 0.238 | 0.469 | 14 |
| 09 | 1 3/4 | 0.120 | 0.266 | 140 | 18 | 6 | 0.284 | 0.531 | 8 |

^A All dimensions are given in inches.

TABLE 15 Type I, Style 10—Common Nails^A

NOTE—Steel wire, flat head, diamond point, round smooth shank, bright, zinc or cement coated as specified.

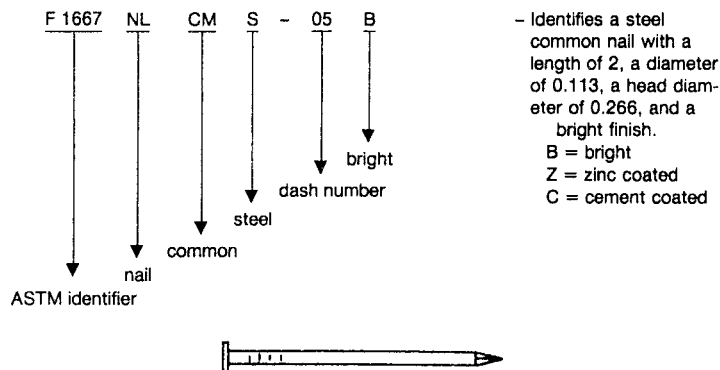

| F 1667 NLCMS | | | | | | | | | | | |
|--------------|----|-------|-------|-------|--------|----------|-----|-------|-------|--------|----|
| Dash No. | S | L | D | H | No./lb | Dash No. | S | L | D | No./lb | |
| 01 | 2d | 1 | 0.072 | 0.172 | 850 | 09 | 10d | 3 | 0.148 | 0.312 | 66 |
| 02 | 3d | 1 1/4 | 0.080 | 0.203 | 540 | 10 | 12d | 3 1/4 | 0.148 | 0.312 | 61 |
| 03 | 4d | 1 1/2 | 0.099 | 0.250 | 290 | 11 | 16d | 3 1/2 | 0.162 | 0.344 | 47 |
| 04 | 5d | 1 3/4 | 0.099 | 0.250 | 250 | 12 | 20d | 4 | 0.192 | 0.406 | 30 |
| 05 | 6d | 2 | 0.113 | 0.266 | 170 | 13 | 30d | 4 1/2 | 0.207 | 0.438 | 23 |
| 06 | 7d | 2 1/4 | 0.113 | 0.266 | 150 | 14 | 40d | 5 | 0.226 | 0.469 | 17 |
| 07 | 8d | 2 1/2 | 0.131 | 0.281 | 100 | 15 | 50d | 5 1/2 | 0.244 | 0.500 | 14 |
| 08 | 9d | 2 3/4 | 0.131 | 0.281 | 92 | 16 | 60d | 6 | 0.262 | 0.531 | 11 |

^A All dimensions are given in inches.

of a driven fastener, depending on the fastener size, amount of cement coating applied, and method of driving.

10.2.2 Chemical etching shall remove the polish of fabrication and roughen the surface microscopically.

10.2.3 Blued nails shall be heated to form a thin, colored oxide on the surface.

10.2.4 Miscellaneous finishes, such as tin plating, liquor,

TABLE 16 Type I, Style 10—Common Nails^A

NOTE—Aluminum alloy wire, or steel wire, (bright, zinc coated or cement coated), altered or T-head, diamond or chisel point, round smooth shank, as specified. For use with mechanical drivers.

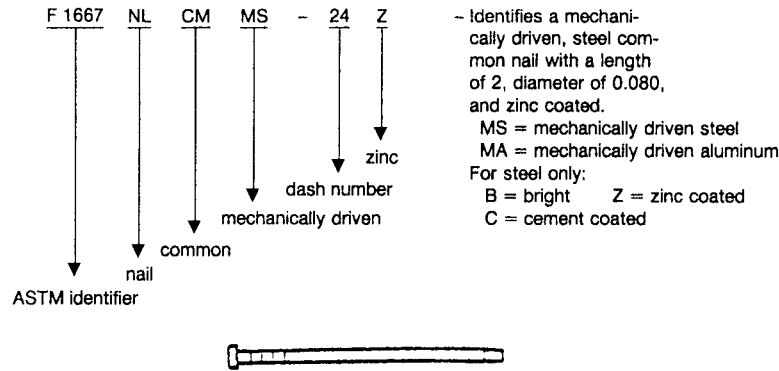

F 1667 NLCMM

| Dash No. | L | D | Dash No. | L | D | Dash No. | L | D |
|----------|----|-------|----------|----|-------|----------|-----|-------|
| 01 | 1¼ | 0.080 | 14 | 1¾ | 0.080 | 27 | 2 | 0.099 |
| 02 | 1¼ | 0.086 | 15 | 1¾ | 0.086 | 28 | 2 | 0.113 |
| 03 | 1¼ | 0.092 | 16 | 1¾ | 0.092 | 29 | 2 | 0.148 |
| 04 | 1¼ | 0.099 | 17 | 1¾ | 0.099 | 30 | 2¼ | 0.092 |
| 05 | 1½ | 0.080 | 18 | 1¾ | 0.113 | 31 | 2¼ | 0.099 |
| 06 | 1½ | 0.086 | 19 | 1¾ | 0.080 | 32 | 2¼ | 0.113 |
| 07 | 1½ | 0.092 | 20 | 1¾ | 0.086 | 33 | 2½ | 0.092 |
| 08 | 1½ | 0.099 | 21 | 1¾ | 0.092 | 34 | 2½ | 0.099 |
| 09 | 1½ | 0.113 | 22 | 1¾ | 0.099 | 35 | 2½ | 0.113 |
| 10 | 1⅝ | 0.080 | 23 | 1¾ | 0.113 | 36 | 2½ | 0.131 |
| 11 | 1⅝ | 0.086 | 24 | 2 | 0.080 | 37 | 3½ | 0.131 |
| 12 | 1⅝ | 0.092 | 25 | 2 | 0.086 | ... | ... | ... |
| 13 | 1⅝ | 0.099 | 26 | 2 | 0.092 | ... | ... | ... |

^A All dimensions are given in inches.

brass plating, copper plating, phosphate coating, or oil coating, shall be applied.

10.3 Altered Shapes and Deformations:

10.3.1 Mechanically formed or deformed nail shanks shall have barbs, flutes, threads, or angular serrations formed onto the wire from which the nail is manufactured. Mechanically deformed shanks shall have vertical or helical flutes or screw-type or annular (ring)-type deformations rolled onto the shank. Symmetrical helical shank deformations shall be obtained by twisting square wire. The deformations shall pass entirely around the shank body, resulting in expanded ridges and depressions. Nails with formed or deformed shanks may be fabricated from round or square wire.

10.3.2 Mechanically formed or deformed nail heads shall be round or T-headed; or they shall be altered round for suitable use in a given make and model of a power-driving fastening system.

10.3.3 Staples manufactured for intended use in power tools shall comply with the tool manufacturer's specification or Type IV, Style 3 (Table 59 or Table 60).

11. Certification

11.1 When specified in the purchase order, a producer's or supplier's certification shall be furnished to the purchaser, indicating that the fasteners are in compliance with this

specification and the purchase order.

12. Packaging and Package Marking

12.1 Unless otherwise specified, fasteners shall be in substantial commercial containers of the type, size, and kind commonly used for the purpose, so constructed as to preserve the contents in good condition and to ensure acceptance and safe delivery by common or other carriers to the point of delivery. In addition, the containers shall be so made that the contents can be removed partially without destroying the container's ability to serve as a receptacle for the remainder of the contents.

12.2 When specified, individual packages and shipping containers shall be marked with the part identifying number and type; length; diameter (or gage, as applicable) of the fastener; the name of the manufacturer or distributor; and the quantity or net weight. Individual packages shall also be marked with the name of the manufacturer or distributor and the quantity or weight of the contents.

13. Keywords

13.1 diameter; driven fasteners; head; length; nails; point; spikes; staples

ASTM F 1667

TABLE 17 Type I, Style 11—Concrete Nails^A

NOTE—Hardened steel, flat countersunk head, diamond point, smooth or mechanically deformed shank formed from round or square stock, as specified, bright finish.

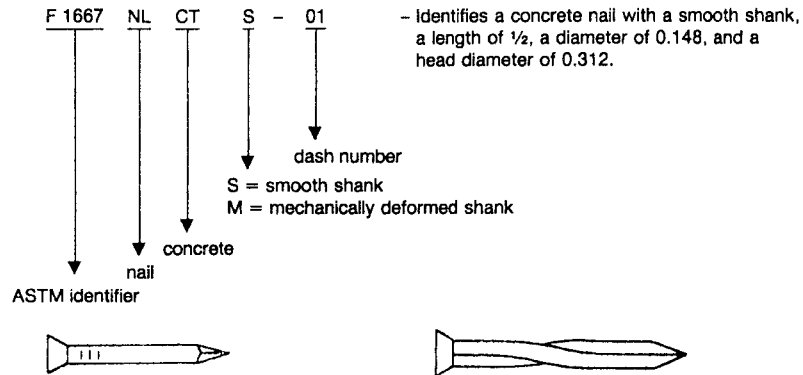

F 1667 NLCTS

| Dash No. | L | D | H | No./lb |
|----------|-----|-------|-------|--------|
| 01 | 1/2 | 0.148 | 0.312 | 450 |
| 02 | 5/8 | 0.148 | 0.312 | 350 |
| 03 | 3/4 | 0.148 | 0.312 | 290 |
| 04 | 7/8 | 0.148 | 0.312 | 250 |
| 05 | 1 | 0.148 | 0.312 | 210 |

F 1667 NLCTM

| Dash No. | L | D | H | No./lb | Dash No. | L | D | H | No./lb |
|----------|-------|-------|-------|--------|----------|-------|-------|-------|--------|
| 01 | 3/4 | 0.181 | 0.284 | 240 | 05 | 2 | 0.181 | 0.284 | 93 |
| 02 | 1 | 0.181 | 0.284 | 204 | 06 | 2 1/2 | 0.181 | 0.284 | 68 |
| 03 | 1 1/2 | 0.181 | 0.284 | 116 | 07 | 2 3/4 | 0.181 | 0.284 | 60 |
| 04 | 1 3/4 | 0.181 | 0.284 | 112 | 08 | 3 | 0.181 | 0.284 | 52 |

^A All dimensions are given in inches.

TABLE 18 Type I, Style 12—Double-Headed Nails^A

NOTE—Steel wire, flat heads, diamond point, round smooth shank, bright finish or cement coated.

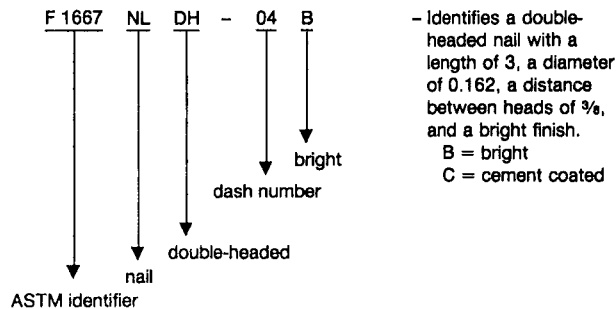

| Dash No. | S | L | D | B | No./lb | Dash No. | S | L | D | B | No./lb |
|----------|-----|-------|-------|------|--------|----------|-----|-------|-------|------|--------|
| 01 | 6d | 1 3/4 | 0.113 | 1/4 | 160 | 04 | 16d | 3 | 0.162 | 3/8 | 45 |
| 02 | 8d | 2 1/4 | 0.131 | 1/4 | 90 | 05 | 20d | 3 1/2 | 0.192 | 3/8 | 28 |
| 03 | 10d | 2 3/4 | 0.148 | 5/16 | 59 | 06 | 30d | 4 | 0.207 | 7/16 | 22 |

^A All dimensions are given in inches.

ASTM F 1667

TABLE 19 Type I, Style 13—Fine Nails^A

NOTE—Steel or copper wire, flat head, diamond point, round smooth shank, bright finish.

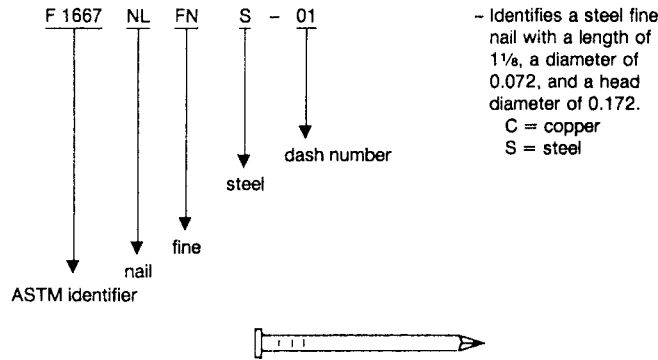

| Dash No. | S | L | D | H | No./lb |
|----------|----|-------|-------|-------|--------|
| 01 | 3d | 1 1/8 | 0.072 | 0.172 | 760 |

^A All dimensions are given in inches.

TABLE 20 Type I, Style 14—Finish Nails^A

NOTE—Steel wire, brad head, altered or clipped T-head for use with mechanical drivers, diamond or chisel point, smooth or barbed shank formed from round or square stock, as specified, bright finished.

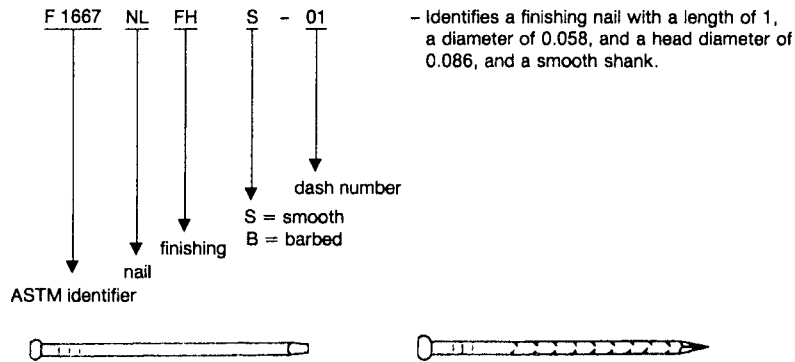

| Dash No. | S | L | D | H | No./lb | Dash No. | S | L | D | H | No./lb |
|----------|----|-------|-------|-------|--------|----------|-----|-------|-------|-------|--------|
| 01 | 2d | 1 | 0.058 | 0.086 | 1,470 | 07 | 8d | 2 1/2 | 0.099 | 0.142 | 190 |
| 02 | 3d | 1 1/4 | 0.067 | 0.099 | 880 | 08 | 9d | 2 3/4 | 0.099 | 0.142 | 180 |
| 03 | 4d | 1 1/2 | 0.072 | 0.106 | 630 | 09 | 10d | 3 | 0.113 | 0.155 | 120 |
| 04 | 5d | 1 3/4 | 0.072 | 0.106 | 530 | 10 | 12d | 3 1/4 | 0.113 | 0.155 | 110 |
| 05 | 6d | 2 | 0.092 | 0.135 | 290 | 11 | 16d | 3 1/2 | 0.120 | 0.162 | 93 |
| 06 | 7d | 2 1/4 | 0.092 | 0.135 | 250 | 12 | 20d | 4 | 0.135 | 0.177 | 65 |

^A All dimensions are given in inches.

ASTM F 1667

TABLE 21 Type I, Style 15—Flooring Nails^A

NOTE—Hardened steel or steel wire, casing head or flat-cupped countersunk head, diamond or blunt point, round, smooth or mechanically deformed shank, dark (hardened), bright (steel wire) or cement coated, as specified.

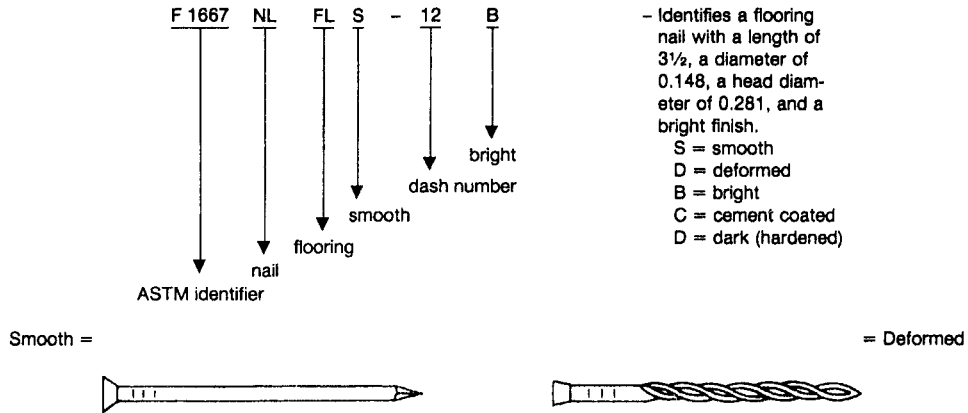

| Dash No. | S | L | D | H | No./lb | Dash No. | S | L | D | H | No./lb |
|----------|----|----|-------|-------|--------|----------|-----|----|-------|-------|--------|
| 01 | 2d | 1 | 0.072 | 0.141 | 840 | 07 | 7d | 2¼ | 0.113 | 0.203 | 160 |
| 02 | 3d | 1¼ | 0.072 | 0.141 | 700 | 08 | 8d | 2½ | 0.135 | 0.177 | 100 |
| 03 | 4d | 1½ | 0.080 | 0.156 | 430 | 09 | 8d | 2½ | 0.113 | 0.203 | 110 |
| 04 | 4d | 1½ | 0.092 | 0.156 | 370 | 10 | 10d | 3 | 0.135 | 0.250 | 82 |
| 05 | 5d | 1¾ | 0.092 | 0.156 | 310 | 11 | 12d | 3¼ | 0.135 | 0.250 | 75 |
| 06 | 6d | 2 | 0.113 | 0.203 | 180 | 12 | 16d | 3½ | 0.148 | 0.281 | 58 |

^A All dimensions are given in inches.

TABLE 22 Type I, Style 16—Lath Nails^A

NOTE—Steel wire, flat head, diamond point, round smooth shank, blued finish.

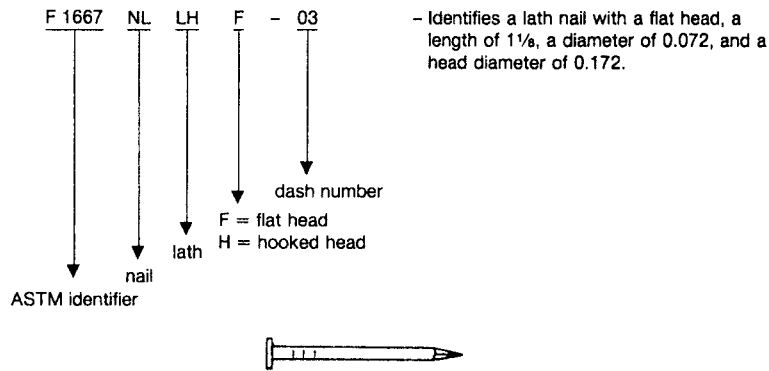

| Dash No. | S | L | D | H | No./lb |
|----------|----|----|-------|-------|--------|
| 01 | 2d | 1 | 0.058 | 0.141 | 1.280 |
| 02 | 3d | 1⅝ | 0.062 | 0.156 | 980 |
| 03 | 3d | 1⅞ | 0.072 | 0.172 | 760 |

^A All dimensions are given in inches.

ASTM F 1667

TABLE 23 Type I, Style 16—Lath Nails^A

NOTE—Steel wire, flat hook-head, diamond point, round smooth shank, bright, blued, or zinc coated as specified.

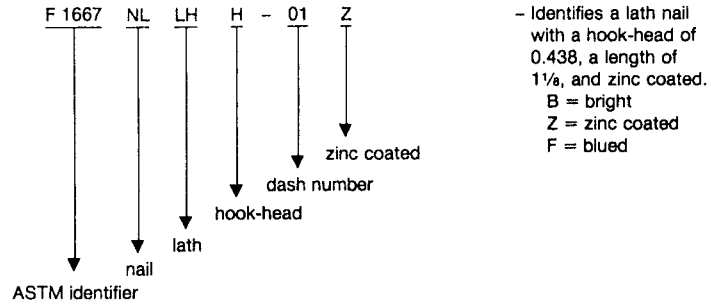

| F 1667 NLLHH | | | | |
|--------------|----------|----------|----------|--------|
| Dash No. | <i>L</i> | <i>D</i> | <i>H</i> | No./lb |
| 01 | 1 1/8 | 0.106 | 0.438 | 280 |

^A All dimensions are given in inches.

ASTM F 1667

TABLE 24 Type I, Style 17—Masonry Nails^A

NOTE—Hardened steel, flat or flat countersunk head, diamond point, mechanically deformed shank, bright finish.

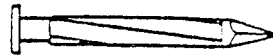
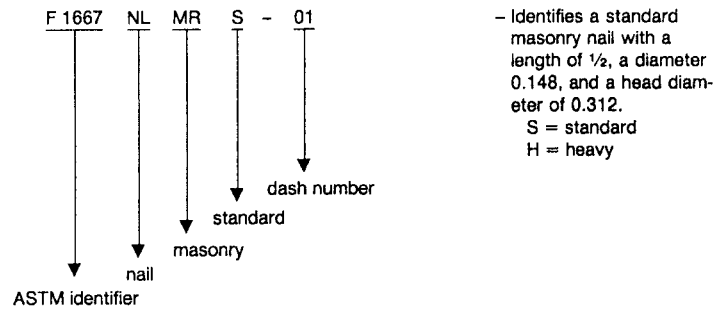

| F 1667 NLMR | | | | | | | | | |
|-------------|-------|-------|-------|--------|----------|-------|-------|-------|--------|
| Dash No. | L | D | H | No./lb | Dash No. | L | D | H | No./lb |
| 01 | 1/2 | 0.148 | 0.312 | 340 | 09 | 2 1/2 | 0.148 | 0.312 | 76 |
| 02 | 3/4 | 0.148 | 0.312 | 280 | 10 | 2 3/4 | 0.148 | 0.312 | 70 |
| 03 | 1 | 0.148 | 0.312 | 170 | 11 | 3 | 0.148 | 0.312 | 67 |
| 04 | 1 1/4 | 0.148 | 0.312 | 140 | 12 | 3 1/4 | 0.148 | 0.312 | 60 |
| 05 | 1 1/2 | 0.148 | 0.312 | 130 | 13 | 3 1/2 | 0.162 | 0.344 | 48 |
| 06 | 1 3/4 | 0.148 | 0.312 | 110 | 14 | 3 3/4 | 0.162 | 0.344 | 45 |
| 07 | 2 | 0.148 | 0.312 | 98 | 15 | 4 | 0.177 | 0.375 | 35 |
| 08 | 2 1/4 | 0.148 | 0.312 | 84 | ... | ... | ... | ... | ... |

| F 1667 NLMRH | | | | | | | | | |
|--------------|-------|-------|-------|--------|----------|-------|-------|-------|--------|
| Dash No. | L | D | H | No./lb | Dash No. | L | D | H | No./lb |
| 01 | 1 | 0.250 | 0.562 | 63 | 05 | 2 | 0.250 | 0.562 | 34 |
| 02 | 1 1/4 | 0.250 | 0.562 | 47 | 06 | 2 1/2 | 0.250 | 0.562 | 27 |
| 03 | 1 1/2 | 0.250 | 0.562 | 43 | 07 | 3 1/2 | 0.250 | 0.562 | 19 |
| 04 | 1 3/4 | 0.250 | 0.562 | 39 | 08 | 3 | 0.250 | 0.562 | 24 |

^A All dimensions are given in inches.

F 1667

TABLE 25 Type I, Style 18—Pallet Nails^A

NOTE—Hardened steel or steel wire (for mechanical drivers), flat head, altered or T-Head (for mechanical drivers), diamond point, round, mechanically deformed shank, bright finish (steel wire), or dark (hardened), as specified.

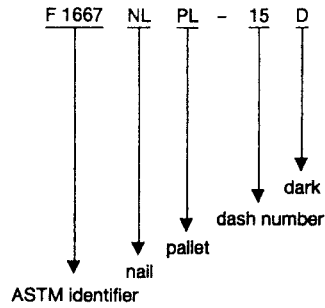

- Identifies a pallet nail with a length of 4, a diameter of 0.177, a head diameter of 0.438, and dark (hardened).
 B = bright
 D = dark (hardened)



| Dash No. | L | D | H | No./lb | Dash No. | L | D | H | No./lb |
|----------|----|-------|-------|--------|----------|---|-------|-------|--------|
| 01 | 1½ | 0.120 | 0.281 | 190 | 11 | ¾ | 0.148 | 0.312 | 61 |
| 02 | 1⅝ | 0.120 | 0.281 | 170 | 12 | ¾ | 0.148 | 0.312 | 57 |
| 03 | 2 | 0.120 | 0.281 | 140 | 13 | ¾ | 0.162 | 0.375 | 47 |
| 04 | 2¼ | 0.120 | 0.281 | 130 | 14 | ¾ | 0.177 | 0.438 | 38 |
| 05 | 2½ | 0.120 | 0.281 | 120 | 15 | 4 | 0.177 | 0.438 | 35 |
| 06 | 2½ | 0.135 | 0.312 | 93 | 16 | 4 | 0.177 | 0.375 | 35 |
| 07 | 3 | 0.120 | 0.281 | 98 | 17 | 5 | 0.177 | 0.375 | 27 |
| 08 | 3 | 0.135 | 0.312 | 79 | 18 | 6 | 0.177 | 0.375 | 23 |
| 09 | 3 | 0.148 | 0.312 | 66 | 19 | 7 | 0.207 | 0.500 | 15 |
| 10 | ¾ | 0.135 | 0.312 | 73 | 20 | 8 | 0.207 | 0.500 | 13 |

^A All dimensions are given in inches.

TABLE 26 Type I, Style 19—Gypsum-Wallboard Nails^A

NOTE—Steel wire, flat head, diamond point, round smooth or deformed shank, bright or blued finish.

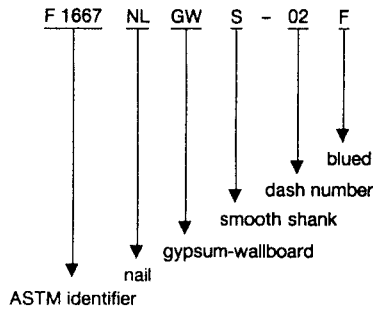

- Identifies a gypsum-wallboard nail with a smooth shank, a length of 1⅝, a diameter of 0.092, a head diameter of 0.375, and blued.
 S = smooth shank
 M = deformed shank
 B = bright
 F = blued

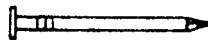

| F 1667 NLGWS | | | | |
|--------------|----|-------|-------|--------|
| Dash No. | L | D | H | No./lb |
| 01 | 1⅝ | 0.092 | 0.297 | 470 |
| 02 | 1⅝ | 0.092 | 0.375 | 450 |
| 03 | 1¼ | 0.092 | 0.297 | 420 |
| 04 | 1¼ | 0.106 | 0.375 | 310 |
| 05 | 1¾ | 0.092 | 0.375 | 290 |

^A All dimensions are given in inches.

F 1667

TABLE 27 Type I, Style 19—Gypsum-Wallboard Nails^A

NOTE—Steel wire, flat slightly countersunk head, long diamond point, round mechanically deformed shank, bright or blued finish.

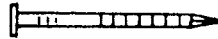

| F 1667 NLGWM | | | | |
|--------------|-------------------------------|-------|-------|--------|
| Dash No. | L | D | H | No./lb |
| 01 | 1 ¹ / ₈ | 0.099 | 0.250 | 380 |
| 02 | 1 ¹ / ₄ | 0.099 | 0.250 | 340 |
| 03 | 1 ³ / ₈ | 0.099 | 0.250 | 320 |
| 04 | 1 ¹ / ₂ | 0.099 | 0.250 | 290 |
| 05 | 1 ⁵ / ₈ | 0.099 | 0.250 | 270 |

^A All dimensions are given in inches.

TABLE 28 Type I, Style 20—Roofing Nails^A

NOTE—Aluminum alloy wire, flat head, diamond point, round smooth shank, or, when specified, square-barbed shank.

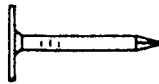
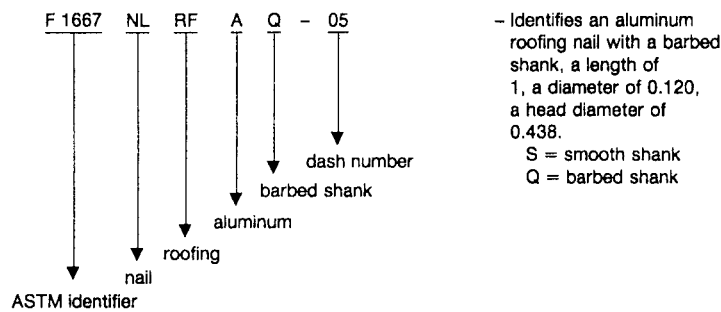

| F 1667 NLRFA | | | | | | | | | |
|--------------|-----|-------|-------|--------|----------|-------------------------------|-------|-------|--------|
| Dash No. | L | D | H | No./lb | Dash No. | L | D | H | No./lb |
| 01 | 3/4 | 0.120 | 0.438 | 940 | 08 | 1 ¹ / ₄ | 0.120 | 0.438 | 620 |
| 02 | 3/4 | 0.135 | 0.438 | 750 | 09 | 1 ¹ / ₄ | 0.135 | 0.438 | 490 |
| 03 | 7/8 | 0.120 | 0.438 | 830 | 10 | 1 ¹ / ₂ | 0.120 | 0.438 | 520 |
| 04 | 7/8 | 0.135 | 0.438 | 660 | 11 | 1 ¹ / ₂ | 0.135 | 0.438 | 420 |
| 05 | 1 | 0.120 | 0.438 | 700 | 12 | 1 ³ / ₄ | 0.135 | 0.438 | 370 |
| 06 | 1 | 0.135 | 0.438 | 600 | 13 | 2 | 0.135 | 0.438 | 340 |
| 07 | 1 | 0.135 | 0.438 | 580 | 14 | 2 ¹ / ₂ | 0.145 | 0.438 | 230 |

^A All dimensions are given in inches.

ASTM F 1667

TABLE 29 Type I, Style 20—Roofing Nails^A

NOTE—Steel wire, flat head, diamond point, round, smooth or barbed shank, bright or zinc coated, as specified, for hand driving or for use with mechanical drivers.

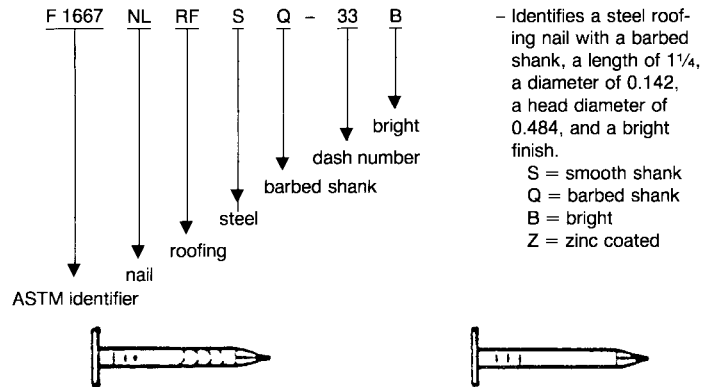

| F 1667 NLRFS | | | | | | | | | |
|--------------|----|-------|-------|--------|----------|-----|-------|-------|--------|
| Dash No. | L | D | H | No./lb | Dash No. | L | D | H | No./lb |
| 01 | ¾ | 0.106 | 0.375 | 460 | 29 | 1¼ | 0.120 | 0.312 | 240 |
| 02 | ¾ | 0.120 | 0.438 | 340 | 30 | 1¼ | 0.120 | 0.438 | 220 |
| 03 | ¾ | 0.135 | 0.469 | 270 | 31 | 1¼ | 0.120 | 0.500 | ... |
| 04 | ¾ | 0.142 | 0.484 | 240 | 32 | 1¼ | 0.135 | 0.469 | 180 |
| 05 | ¾ | 0.148 | 0.500 | 220 | 33 | 1¼ | 0.142 | 0.484 | 160 |
| 06 | ¾ | 0.162 | 0.500 | 200 | 34 | 1¼ | 0.148 | 0.500 | 140 |
| 07 | ⅞ | 0.106 | 0.375 | ... | 35 | 1¼ | 0.162 | 0.500 | 120 |
| 08 | ⅞ | 0.120 | 0.438 | 300 | 36 | 1½ | 0.106 | 0.375 | ... |
| 09 | ⅞ | 0.120 | 0.500 | 250 | 37 | 1½ | 0.120 | 0.438 | 180 |
| 10 | ⅞ | 0.135 | 0.469 | 240 | 38 | 1½ | 0.120 | 0.500 | 160 |
| 11 | ⅞ | 0.142 | 0.484 | 210 | 39 | 1½ | 0.135 | 0.469 | 150 |
| 12 | ⅞ | 0.148 | 0.500 | 190 | 40 | 1½ | 0.142 | 0.484 | 130 |
| 13 | ⅞ | 0.162 | 0.500 | 170 | 41 | 1½ | 0.148 | 0.500 | 120 |
| 14 | 1 | 0.106 | 0.281 | 380 | 42 | 1½ | 0.162 | 0.500 | 110 |
| 15 | 1 | 0.106 | 0.375 | 360 | 43 | 1¾ | 0.106 | 0.375 | 220 |
| 16 | 1 | 0.120 | 0.438 | 270 | 44 | 1¾ | 0.120 | 0.438 | 160 |
| 17 | 1 | 0.120 | 0.500 | 220 | 45 | 1¾ | 0.120 | 0.500 | 140 |
| 18 | 1 | 0.135 | 0.469 | 210 | 46 | 1¾ | 0.135 | 0.469 | 130 |
| 19 | 1 | 0.142 | 0.484 | 190 | 47 | 1¾ | 0.142 | 0.484 | 120 |
| 20 | 1 | 0.148 | 0.500 | 170 | 48 | 1¾ | 0.148 | 0.500 | 110 |
| 21 | 1 | 0.162 | 0.500 | 150 | 49 | 1¾ | 0.162 | 0.500 | 92 |
| 22 | 1⅛ | 0.106 | 0.375 | 320 | 50 | ¾ | 0.120 | 0.375 | 290 |
| 23 | 1⅛ | 0.120 | 0.438 | 240 | 51 | ⅞ | 0.120 | 0.375 | 259 |
| 24 | 1⅛ | 0.135 | 0.469 | 190 | 52 | 1 | 0.120 | 0.375 | 232 |
| 25 | 1⅛ | 0.142 | 0.484 | 170 | 53 | 1¼ | 0.120 | 0.375 | 209 |
| 26 | 1⅛ | 0.148 | 0.500 | 160 | 54 | 1½ | 0.120 | 0.375 | 179 |
| 27 | 1⅛ | 0.162 | 0.500 | 140 | 55 | 1¾ | 0.120 | 0.375 | 157 |
| 28 | 1¼ | 0.106 | 0.375 | 300 | ... | ... | ... | ... | ... |

^A All dimensions are given in inches.

ASTM F 1667

TABLE 30 Type I, Style 20—Roofing Nails^A

NOTE—Copper-clad wire, flat head, diamond point, round smooth shank.

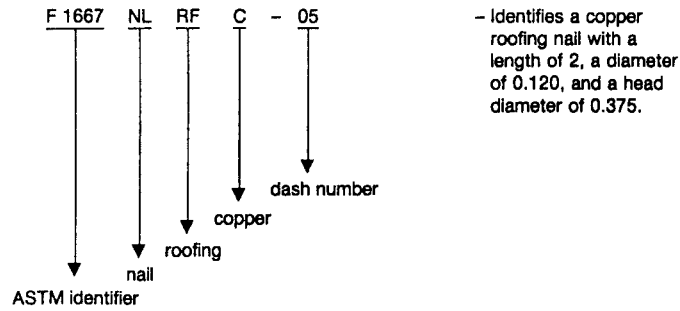

| F 1667 NLRFC | | | | | | | | | | | |
|--------------|----|----|-------|-------|--------|----------|----|----|-------|-------|--------|
| Dash No. | S | L | D | H | No./lb | Dash No. | S | L | D | H | No./lb |
| 01 | 2d | 1 | 0.120 | 0.375 | 280 | 04 | 5d | 1¾ | 0.120 | 0.375 | 160 |
| 02 | 3d | 1¼ | 0.120 | 0.375 | 220 | 05 | 6d | 2 | 0.120 | 0.375 | 140 |
| 03 | 4d | 1½ | 0.120 | 0.375 | 190 | 06 | 7d | 2¼ | 0.120 | 0.375 | 130 |

^A All dimensions are given in inches.

TABLE 31 Type I, Style 20—Roofing Nails^A

NOTE—Steel wire, leak-resistant convex head, diamond point, round smooth shank, zinc coated.

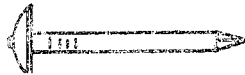
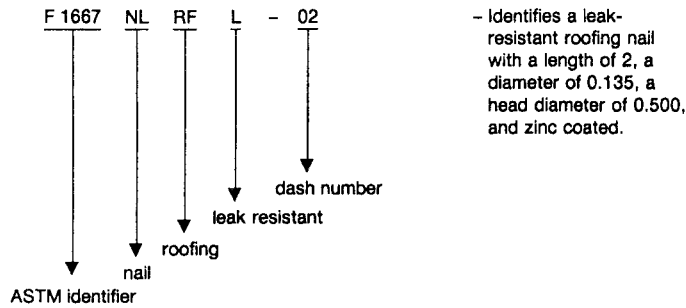

| F 1667 NLRFL | | | | |
|--------------|----|-------|-------|--------|
| Dash No. | L | D | H | No./lb |
| 01 | 1¾ | 0.135 | 0.500 | 110 |
| 02 | 2 | 0.135 | 0.500 | 98 |

^A All dimensions are given in inches.

ASTM F 1667

TABLE 32 Type I, Style 20—Roofing Nails^A

NOTE—Steel wire, flat reinforced head, needle or diamond point, round smooth shank, bright or zinc coated, as specified. (For prepared felt roofing.)

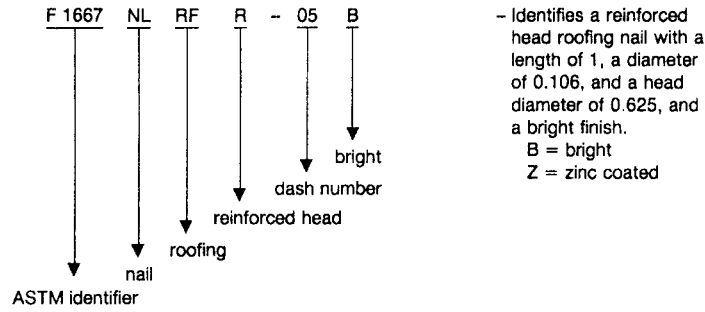

F 1667 NLRFR

| Dash No. | L | D | H | No./lb | Dash No. | L | D | H | No./lb |
|----------|-----|-------|-------|--------|----------|-------|-------|-------|--------|
| 01 | 3/4 | 0.106 | 0.625 | 190 | 06 | 1 | 0.120 | 0.625 | 150 |
| 02 | 3/4 | 0.120 | 0.625 | 170 | 07 | 1 1/8 | 0.106 | 0.625 | 170 |
| 03 | 7/8 | 0.106 | 0.625 | 180 | 08 | 1 1/8 | 0.120 | 0.625 | 140 |
| 04 | 7/8 | 0.120 | 0.625 | 160 | 09 | 1 1/4 | 0.106 | 0.625 | 160 |
| 05 | 1 | 0.106 | 0.625 | 170 | 10 | 1 1/4 | 0.106 | 0.625 | 140 |

^A All dimensions are given in inches.

TABLE 33 Type I, Style 20—Roofing Nails^A

NOTE—Steel wire, 1-in. flat integral steel cap, diamond point, round mechanically deformed shank, bright finish for roofing felts.

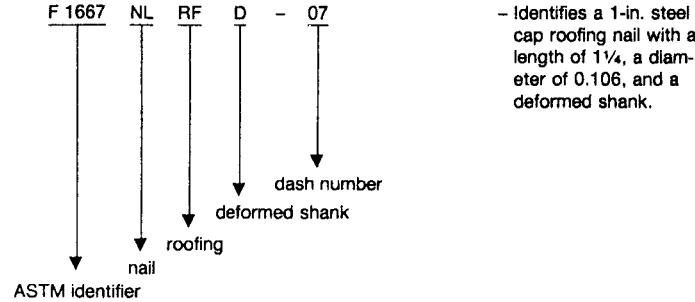

F 1667 NLRFD

| Dash No. | L | D | No./lb | Dash No. | L | D | No./lb |
|----------|-------|-------|--------|----------|-------|---------|--------|
| 01 | 1/2 | 0.106 | 130 | 07 | 1 1/4 | 106 | 100 |
| 02 | 5/8 | 0.106 | 120 | 08 | 1 1/2 | 106-120 | 96-84 |
| 03 | 3/4 | 0.106 | 115 | 09 | 1 3/4 | 106-120 | 94-85 |
| 04 | 7/8 | 0.106 | 110 | 10 | 2 | 106-120 | 90-74 |
| 05 | 1 | 0.106 | 110 | 11 | 2 1/2 | 106-120 | 80-61 |
| 06 | 1 1/8 | 0.106 | 110 | 12 | 3 | 106 | 70 |

^A All dimensions are given in inches.

F 1667

TABLE 34 Type I, Style 20—Roofing Nails^{A,B}

NOTE—Steel wire, cast lead head, diamond point, round, barbed or ringed shank, bright finish.

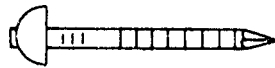
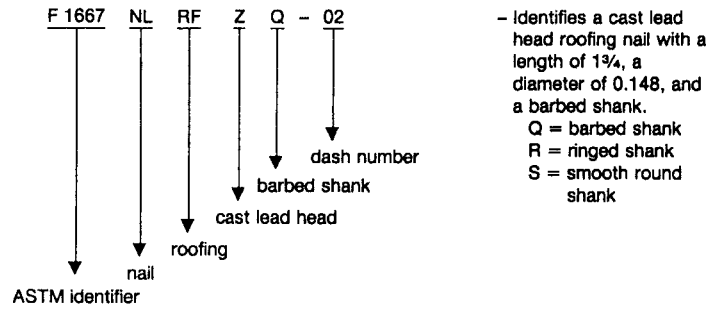

| F 1667 NLRFBZ | | | | F 1667 NLRFBZ | | | |
|---------------|----|-------|--------|---------------|----|-------|--------|
| Dash No. | L | D | No./lb | Dash No. | L | D | No./lb |
| 01 | 1½ | 0.148 | 98 | 01 | 1½ | 0.135 | 110 |
| 02 | 1¾ | 0.148 | 87 | 02 | 1¾ | 0.135 | 110 |
| 03 | 2 | 0.148 | 79 | 03 | 2 | 0.135 | 93 |

^A All dimensions are given in inches.

^B This table is included for historical reference only and is scheduled for deletion in the year 2001.

TABLE 35 Type I, Style 20—Roofing Nails^A

NOTE—Aluminum alloy wire, flat head with neoprene washer (for aluminum roofing sheet), diamond point, round, smooth, or mechanically deformed shank, as specified.

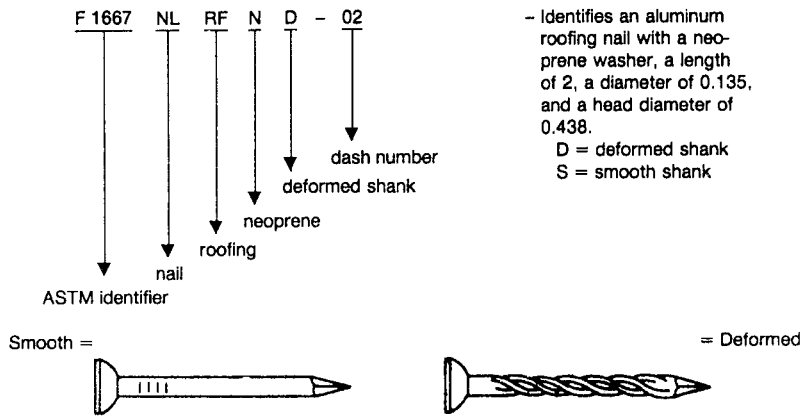

| F 1667 NLRFNS | | | | | F 1667 NLRFND | | | | |
|---------------|----|-------|-------|--------|---------------|----|-------|-------|--------|
| Dash No. | L | D | H | No./lb | Dash No. | L | D | H | No./lb |
| 01 | 1¾ | 0.135 | 0.438 | 320 | 01 | 1¾ | 0.145 | 0.438 | 290 |
| 02 | 2 | 0.135 | 0.438 | 280 | 02 | 2 | 0.145 | 0.438 | 260 |
| 03 | 2¼ | 0.135 | 0.438 | 240 | 03 | 2¼ | 0.145 | 0.438 | 230 |
| 04 | 2½ | 0.135 | 0.438 | 210 | 04 | 2½ | 0.145 | 0.438 | 210 |

^A All dimensions are given in inches.

ASTM F 1667

TABLE 36 Type I, Style 21—Shingle Nails^A

NOTE—Aluminum Alloy wire, flat head, diamond point, round, smooth or mechanically deformed shank, as specified.

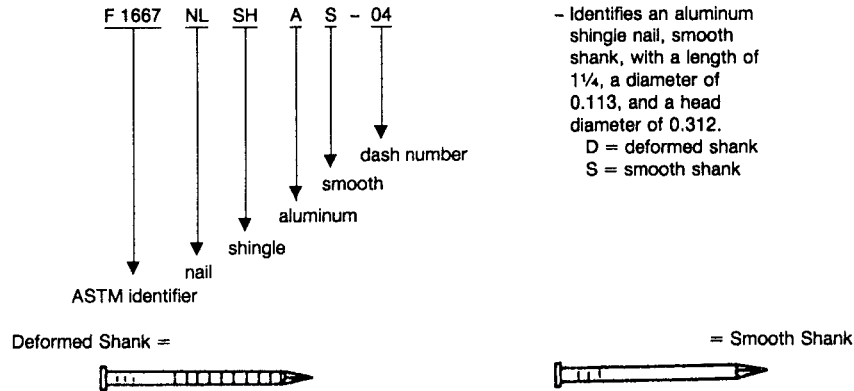

| F 1667 NLSHAD | | | | | F 1667 NLSHAS | | | | |
|---------------|-------|-------|-------|--------|---------------|-------|-------|-------|--------|
| Dash No. | L | D | H | No./lb | Dash No. | L | D | H | No./lb |
| 01 | 1 1/4 | 0.101 | 0.191 | 1060 | 01 | 7/8 | 0.099 | 0.281 | 1310 |
| 02 | 1 1/2 | 0.101 | 0.191 | 860 | 02 | 1 1/4 | 0.080 | 0.219 | 1480 |
| 03 | 1 3/4 | 0.105 | 0.191 | 720 | 03 | 1 1/4 | 0.099 | 0.281 | 1010 |
| 04 | 2 | 0.105 | 0.191 | 610 | 04 | 1 1/4 | 0.113 | 0.312 | 780 |
| 05 | 2 1/4 | 0.113 | 0.200 | 180 | 05 | 1 1/2 | 0.113 | 0.312 | 660 |
| 06 | 2 1/2 | 0.113 | 0.200 | 130 | 06 | 1 3/4 | 0.113 | 0.312 | 610 |

^A All dimensions are given in inches.

TABLE 37 Type I, Style 21—Shingle Nails^A

NOTE—Steel wire, flat head, diamond point, round, smooth (standard) or barbed (for special shingles) shank, bright or zinc coated, as specified.

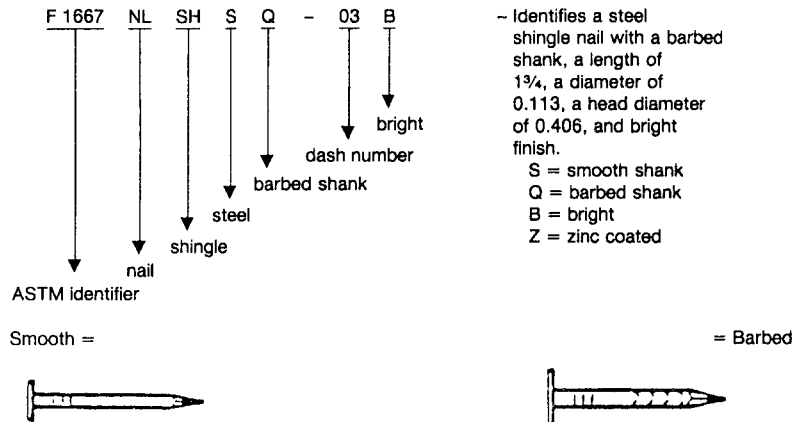

| F 1667 NLSHSS | | | | | | F 1667 NLSHNSB | | | | |
|---------------|------|-------|-------|-------|--------|----------------|-------|-------|-------|--------|
| Dash No. | S | L | D | H | No./lb | Dash No. | L | D | H | No./lb |
| 01 | 3d | 1 1/4 | 0.092 | 0.250 | 410 | 01 | 1 1/4 | 0.113 | 0.406 | 250 |
| 02 | 3.5d | 1 3/8 | 0.099 | 0.281 | 310 | 02 | 1 1/2 | 0.113 | 0.406 | 210 |
| 03 | 4d | 1 1/2 | 0.106 | 0.281 | 260 | 03 | 1 3/4 | 0.113 | 0.406 | 180 |
| ... | ... | ... | ... | ... | ... | 04 | 2 | 0.113 | 0.406 | 162 |

^A All dimensions are given in inches.

ASTM F 1667

TABLE 38 Type I, Style 22—Siding Nails^A

NOTE—Aluminum alloy wire, flat head (insulated), casing or countersunk head (wood), as specified, diamond point, round smooth shank or, when specified, square-barbed shank.

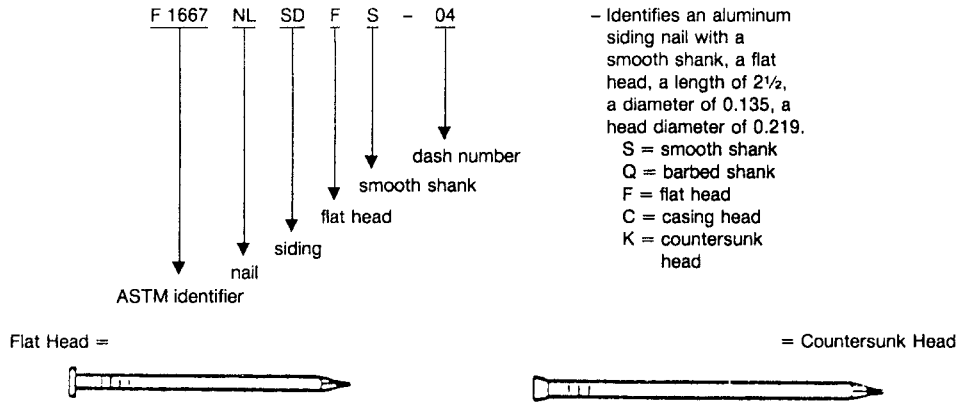

| F 1667 NLSDF | | | | |
|--------------|----|-------|-------|--------|
| Dash No. | L | D | H | No./lb |
| 01 | 1½ | 0.113 | 0.219 | 700 |
| 02 | 1½ | 0.113 | 0.312 | 660 |
| 03 | 2 | 0.113 | 0.219 | 490 |
| 04 | 2½ | 0.135 | 0.219 | 290 |

| F 1667 NLSDC | | | | | | F 1667 NLSDK | | | | | |
|--------------|----|----|-------|-------|--------|--------------|----|----|-------|-------|--------|
| Dash No. | S | L | D | H | No./lb | Dash No. | S | L | D | H | No./lb |
| 01 | 6d | 1⅞ | 0.106 | 0.141 | 600 | 01 | 6d | 1⅞ | 0.106 | 0.266 | 600 |
| 02 | 7d | 2⅞ | 0.113 | 0.141 | 470 | 02 | 7d | 2⅞ | 0.113 | 0.266 | 470 |
| 03 | 8d | 2⅞ | 0.128 | 0.156 | 320 | 03 | 8d | 2⅞ | 0.128 | 0.297 | 320 |
| 04 | 9d | 2⅞ | 0.148 | 0.189 | 200 | 04 | 9d | 2⅞ | 0.148 | 0.312 | 200 |

^A All dimensions are given in inches.

ASTM F 1667

TABLE 39 Type I, Style 23—Slating Nails^A

NOTE—Aluminum alloy, copper or steel wire as specified. Aluminum and copper nails shall have a flat head (0.312 to 0.375-in. diameter), diamond point, and round smooth shank or, when specified, square-barbed shank. Steel nails shall have a flat, slightly countersunk head, diamond point, round smooth shank, zinc coated.

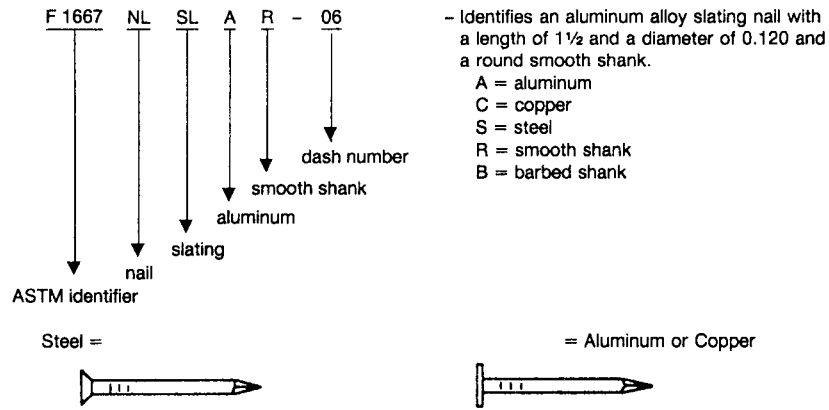

| F 1667 NLSLA | | | | | |
|--------------|-----|-------|-------|-------|--------|
| Dash No. | L | D | | | |
| 01 | 7/8 | 0.106 | | | |
| 02 | 1 | 0.106 | | | |
| 03 | 1¼ | 0.106 | | | |
| 04 | 1¼ | 0.120 | | | |
| 05 | 1¼ | 0.135 | | | |
| 06 | 1½ | 0.120 | | | |
| 07 | 1½ | 0.135 | | | |
| F 1667 NLSLC | | | | | |
| 01 | 1 | 0.109 | | | |
| 02 | 1¼ | 0.109 | | | |
| 03 | 1¼ | 0.120 | | | |
| 04 | 1¼ | 0.135 | | | |
| 05 | 1½ | 0.109 | | | |
| 06 | 1½ | 0.120 | | | |
| 07 | 1½ | 0.135 | | | |
| 08 | 1¾ | 0.135 | | | |
| 09 | 2 | 0.135 | | | |
| F 1667 NLSLS | | | | | |
| Dash No. | S | L | D | H | No./lb |
| 01 | 2d | 1 | 0.106 | 0.312 | 420 |
| 02 | 3d | 1¼ | 0.128 | 0.375 | 220 |
| 03 | 4d | 1½ | 0.128 | 0.375 | 190 |
| 04 | 5d | 1¾ | 0.135 | 0.406 | 140 |
| 05 | 6d | 2 | 0.148 | 0.438 | 100 |

^A All dimensions are given in inches.

ASTM F 1667

TABLE 40 Type I, Style 24—Rubber Heel Nails^A

NOTE—Steel wire, flat or countersunk head, as specified, needle point, round smooth shank, bright finish.

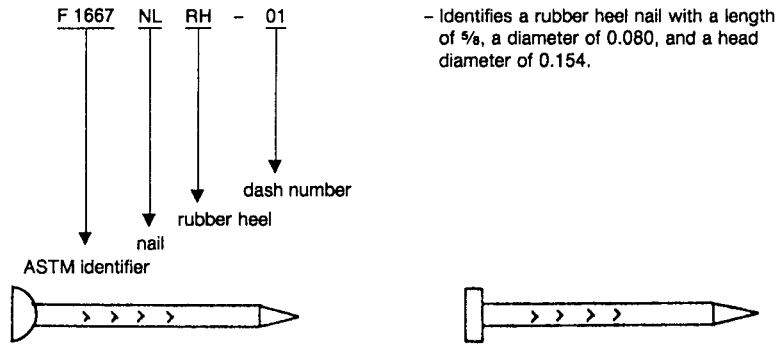

| Dash No. | L | D | H | Dash No. | L | D | H |
|----------|-----|-------|-------|----------|-------|-------|-------|
| 01 | 5/8 | 0.080 | 0.154 | 04 | 1 | 0.080 | 0.154 |
| 02 | 3/4 | 0.080 | 0.154 | 05 | 1 1/8 | 0.080 | 0.154 |
| 03 | 7/8 | 0.080 | 0.154 | 06 | 1 1/4 | 0.080 | 0.154 |

^A All dimensions are given in inches.

TABLE 41 Type I, Style 25—Underlayment Nails^A

NOTE—Steel wire, flat or flat, slightly countersunk head, diamond point, round, mechanically deformed shank, bright finish.

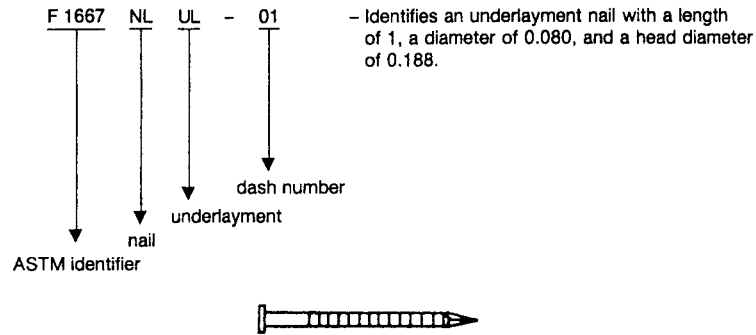

| Dash No. | L | D | H | No./lb | Dash No. | L | D | H | S | No./lb |
|----------|-------|-------|-------|--------|----------|-------|-------|-------|-----|--------|
| 01 | 1 | 0.080 | 0.188 | ... | 07 | 1 1/2 | 0.099 | 0.250 | ... | 330 |
| 02 | 1 1/4 | 0.080 | 0.188 | 600 | 08 | 1 5/8 | 0.099 | 0.250 | ... | 300 |
| 03 | 1 1/4 | 0.099 | 0.250 | 400 | 09 | 1 3/4 | 0.099 | 0.250 | ... | 280 |
| 04 | 1 3/8 | 0.080 | 0.188 | 540 | 10 | 1 7/8 | 0.106 | 0.266 | 6d | 170 |
| 05 | 1 3/8 | 0.099 | 0.250 | 360 | 11 | 2 1/8 | 0.109 | 0.266 | 7d | 170 |
| 06 | 1 1/2 | 0.080 | 0.188 | 500 | 12 | 2 3/8 | 0.113 | 0.297 | 8d | 140 |

^A All dimensions are given in inches.

ASTM F 1667

TABLE 42 Type I, Style 26—Barbed Nails^A

NOTE—Steel wire, flat head, diamond point, square barbed shank, bright finish.

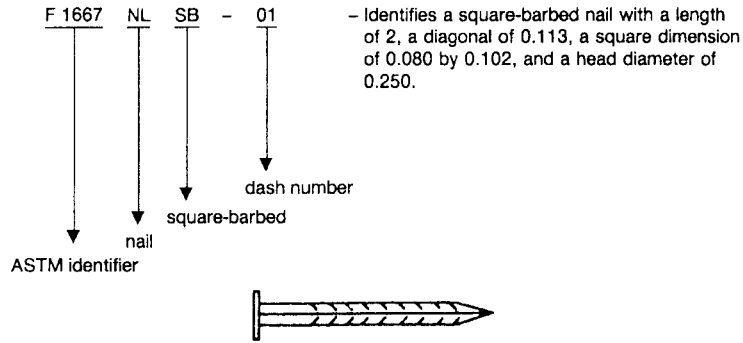

| Dash No. | S | Style | L | Diagonal | Square Dimension | H | No./lb |
|----------|-----|--------|----|----------|------------------|-------|--------|
| 01 | 6d | common | 2 | 0.113 | 0.080 × 0.102 | 0.250 | 200 |
| 02 | 8d | common | 2½ | 0.131 | 0.092 × 0.120 | 0.266 | 120 |
| 03 | 10d | common | 3 | 0.148 | 0.105 × 0.135 | 0.281 | 84 |
| 04 | 16d | common | 3½ | 0.162 | 0.113 × 0.149 | 0.312 | 59 |
| 05 | 20d | common | 4 | 0.192 | 0.135 × 0.170 | 0.375 | 39 |
| 06 | 6d | box | 2 | 0.099 | 0.072 × 0.089 | 0.250 | 260 |
| 07 | 8d | box | 2½ | 0.113 | 0.080 × 0.102 | 0.266 | 150 |
| 08 | 6d | finish | 2 | 0.092 | 0.062 × 0.083 | 0.124 | 320 |
| 09 | 8d | finish | 2½ | 0.099 | 0.072 × 0.089 | 0.131 | 230 |
| 10 | ... | truss | 1½ | 0.131 | 0.092 × 0.120 | 0.281 | 190 |

^A All dimensions are given in inches.

TABLE 43 Type I, Style 27—Masonry Drive Nails^A

NOTE—Hardened steel, flat head, cone pilot point, round, high pitch, multiple-start threaded shank, bright finish. When specified, masonry drive nails shall be proof lead tested.

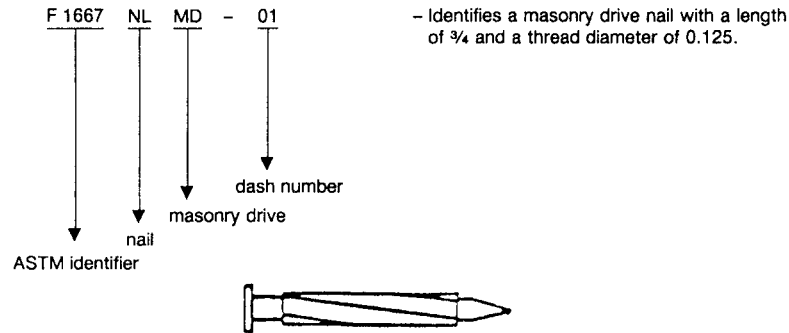

| Dash No. | S | L | Thread Diameter | Dash No. | S | L | Thread Diameter |
|----------|------|---|-----------------|----------|------|----|-----------------|
| 01 | 3/32 | ¾ | 0.125 | 4 | 3/16 | 1¼ | 0.215 |
| 02 | 1/8 | ¾ | 0.156 | 5 | ¼ | 1½ | 0.258 |
| 03 | 5/32 | 1 | 0.188 | 6 | 5/16 | 2 | 0.330 |

^A All dimensions are given in inches.

ASTM F 1667

TABLE 44 Type I, Style 28—Escutcheon Nails^A

NOTE—Steel or brass wire, as specified, oval head, diamond point, round smooth shank.

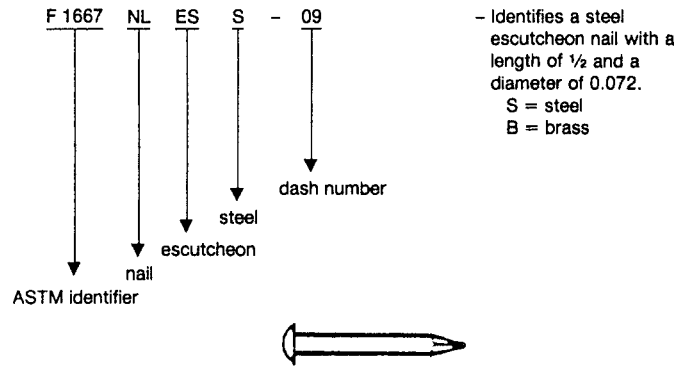

| Dash No. | L | D | Dash No. | L | D | Dash No. | L | D |
|----------|-----|-------|----------|-------|-------|----------|-----|-------|
| 01 | 1/4 | 0.035 | 14 | 3/4 | 0.072 | 27 | 2 | 0.080 |
| 02 | 1/4 | 0.048 | 15 | 3/4 | 0.080 | 28 | 2 | 0.092 |
| 03 | 1/4 | 0.062 | 16 | 3/4 | 0.092 | ... | ... | ... |
| 04 | 1/4 | 0.072 | 17 | 1 | 0.048 | ... | ... | ... |
| 05 | 1/4 | 0.080 | 18 | 1 | 0.062 | ... | ... | ... |
| 06 | 1/2 | 0.035 | 19 | 1 | 0.072 | ... | ... | ... |
| 07 | 1/2 | 0.048 | 20 | 1 | 0.080 | ... | ... | ... |
| 08 | 1/2 | 0.062 | 21 | 1 | 0.092 | ... | ... | ... |
| 09 | 1/2 | 0.072 | 22 | 1 1/4 | 0.062 | ... | ... | ... |
| 10 | 1/2 | 0.080 | 23 | 1 1/4 | 0.080 | ... | ... | ... |
| 11 | 1/2 | 0.092 | 24 | 1 1/4 | 0.092 | ... | ... | ... |
| 12 | 3/4 | 0.048 | 25 | 1 1/2 | 0.080 | ... | ... | ... |
| 13 | 3/4 | 0.062 | 26 | 1 1/2 | 0.092 | ... | ... | ... |

^A All dimensions are given in inches.

TABLE 45 Type I, Style 29—Glulam Rivet^A

NOTE—Hardened steel, flat countersunk head, diamond point, smooth shank, zinc coated, as specified.

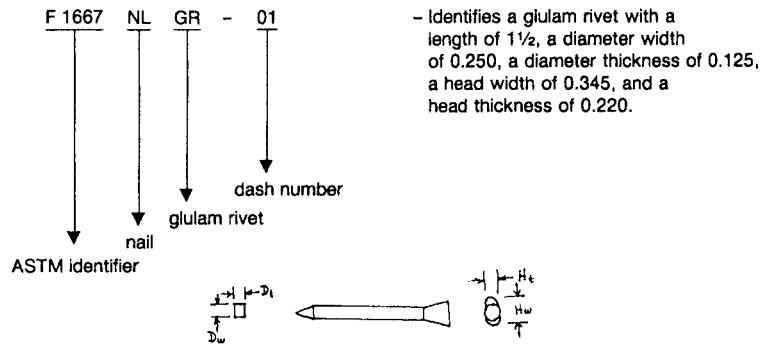

| Dash No. | L | D _{width} ^B | D _{thickness} ^B | H _{width} ^B | H _{thickness} ^B | No./lb |
|----------|-------|---------------------------------|-------------------------------------|---------------------------------|-------------------------------------|--------|
| 01 | 1 1/2 | 0.250 | 0.125 | 0.345 | 0.220 | 59 |
| 02 | 2 1/2 | 0.250 | 0.125 | 0.345 | 0.220 | 34 |
| 03 | 3 1/2 | 0.250 | 0.125 | 0.345 | 0.220 | 24 |

^A All dimensions are given in inches.

^B Tolerances: D_w - ±0.010, D_t - ±0.005, H_w - ±0.010, and H_t - ±0.010.

ASTM F 1667

TABLE 48 Type II, Style 3—Clout Cut Nails^A

NOTE—Steel, flat head, bright finish, blued or zinc coated, as specified (see 5.1).

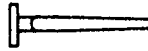
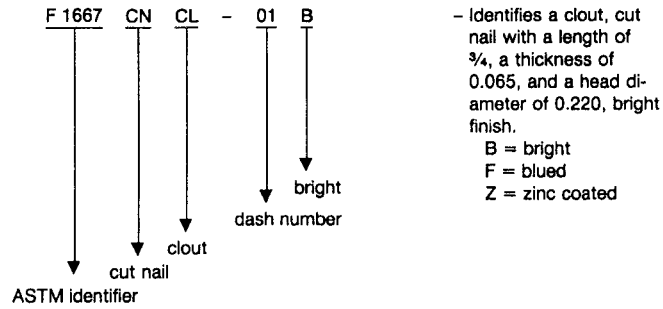

| Dash No. | L | T | H | No./lb |
|----------|-------|--------|-------|--------|
| 01 | 3/4 | 0.065 | 0.220 | 960 |
| 02 | 7/8 | 0.0685 | 0.238 | 770 |
| 03 | 1 | 0.072 | 0.259 | 580 |
| 04 | 1 1/4 | 0.0775 | 0.284 | 380 |

^A All dimensions are given in inches.

TABLE 49 Type II, Style 4—Common Cut Nails^A

NOTE—Steel, oval head, bright finish, blued, brass or copper plated, as specified.

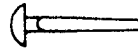
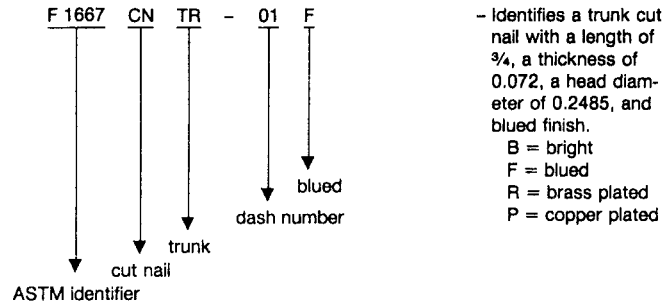

| Dash No. | L | T | H | No./lb |
|----------|-------|-------|--------|--------|
| 01 | 3/4 | 0.072 | 0.2485 | 670 |
| 02 | 7/8 | 0.072 | 0.2485 | 610 |
| 03 | 1 | 0.083 | 0.2715 | 450 |
| 04 | 1 1/4 | 0.083 | 0.2715 | 350 |

^A All dimensions are given in inches.

ASTM F 1667

TABLE 50 Type II, Style 5—Cobblers Cut Nails^A

NOTE—Steel casing head, clinch point, bright finish or brass plated, as specified.

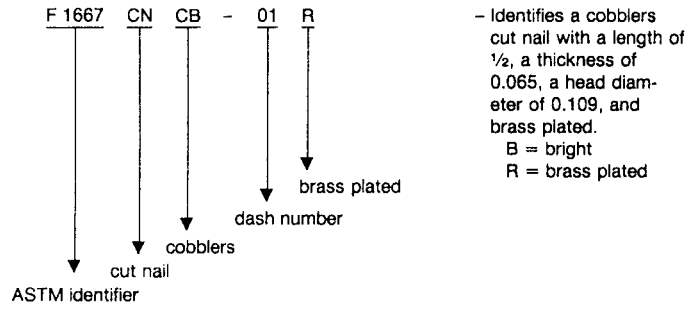

| Dash No. | L | T | H | No./lb |
|----------|-----|-------|-------|--------|
| 01 | 1/2 | 0.065 | 0.109 | 1950 |
| 02 | 5/8 | 0.065 | 0.109 | 1500 |
| 03 | 3/4 | 0.065 | 0.109 | 1340 |

^A All dimensions are given in inches.

TABLE 51 Type II, Style 6—Extra-Iron Clinching Cut Nails^A

NOTE—Steel, casing head, clinch point, bright finish or blued, as specified.

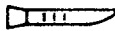
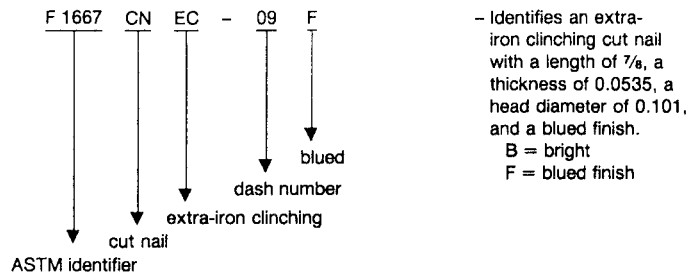

| Dash No. | L | T | H | No./lb | Dash No. | L | T | H | No./lb |
|----------|------|-------|-------|--------|----------|--------|--------|-------|--------|
| 01 | 3/8 | 0.049 | 0.093 | 4.130 | 06 | 1 1/16 | 0.049 | 0.093 | 2000 |
| 02 | 7/16 | 0.049 | 0.093 | 3.400 | 07 | 3/4 | 0.0535 | 0.101 | 1640 |
| 03 | 1/2 | 0.049 | 0.093 | 3.040 | 08 | 13/16 | 0.0535 | 0.101 | 1600 |
| 04 | 9/16 | 0.049 | 0.093 | 2.864 | 09 | 7/8 | 0.0535 | 0.101 | 1520 |
| 05 | 5/8 | 0.049 | 0.093 | 2.260 | ... | ... | ... | ... | ... |

^A All dimensions are given in inches.

ASTM F 1667

TABLE 52 Type II, Style 7—Hob Cut Nails^A

NOTE—Steel, square grooved head, clinch point, bright finish, or blued, as specified.

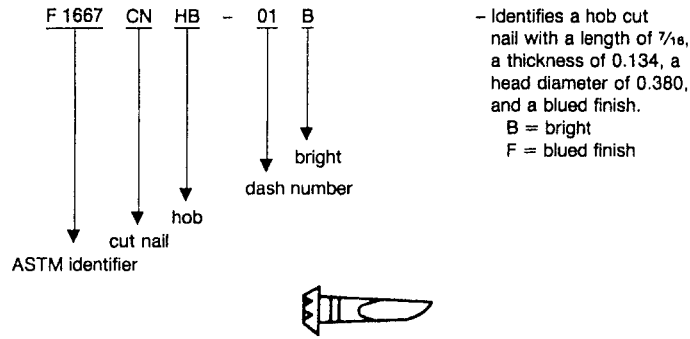

| Dash No. | L | T | H | No./lb |
|----------|------|-------|-------|--------|
| 01 | 7/16 | 0.134 | 0.380 | 270 |
| 02 | 1/2 | 0.134 | 0.380 | 260 |

^A All dimensions are given in inches.

TABLE 53 Type III, Style 1—Common Spikes^A

NOTE—These spikes shall be sheared from medium carbon sheet steel and shall have a wedged-shaped shank with a square point end narrower than the upset head end. They shall have a flat head, bright finish, or zinc coated, as specified.

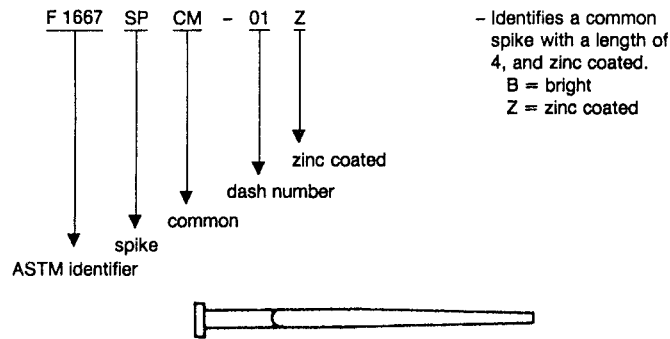

| Dash No. | S | L | Dash No. | S | L |
|----------|-----|-------|----------|------|-----|
| 01 | 20d | 4 | 05 | 60d | 6 |
| 02 | 30d | 4 1/2 | 06 | 80d | 7 |
| 03 | 40d | 5 | 07 | 100d | 8 |
| 04 | 50d | 5 1/2 | ... | ... | ... |

^A All dimensions are given in inches.

ASTM F 1667

TABLE 54 Type III, Style 2—Gutter Spikes^A

NOTE—Steel wire, oval head, chisel point, flat head, diamond point, bright finish or zinc coated, as specified.

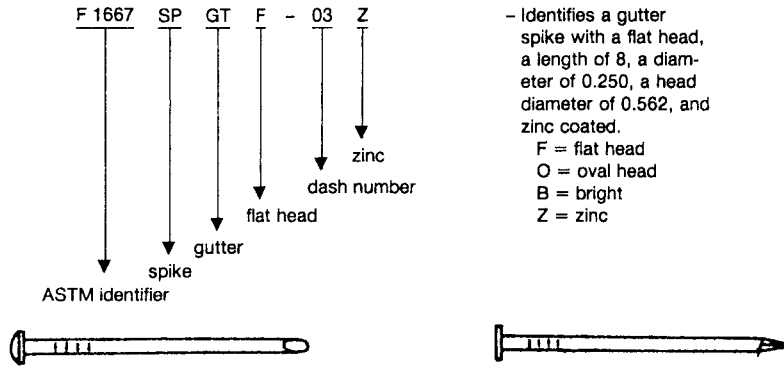

| F 1667 SPGTF | | | |
|--------------|-----|-------|-------|
| Dash No. | L | D | H |
| 01 | 6½ | 0.250 | 0.562 |
| 02 | 7 | 0.250 | 0.562 |
| 03 | 8 | 0.250 | 0.562 |
| 04 | 8½ | 0.250 | 0.562 |
| 05 | 9 | 0.250 | 0.562 |
| 06 | 10 | 0.250 | 0.562 |
| 07 | 10½ | 0.250 | 0.562 |
| F 1667 SPGTO | | | |
| Dash No. | L | D | H |
| 01 | 6½ | 0.250 | 0.531 |
| 02 | 7 | 0.250 | 0.531 |
| 03 | 8 | 0.250 | 0.531 |
| 04 | 8½ | 0.250 | 0.531 |
| 05 | 9 | 0.250 | 0.531 |
| 06 | 10 | 0.250 | 0.531 |
| 07 | 10½ | 0.250 | 0.531 |

^A All dimensions are given in inches.

ASTM F 1667

TABLE 55 Type III, Style 3—Round Spikes^A

NOTE—Steel wire, oval countersunk head, chisel point, flat head, diamond point, bright finish or zinc coated, as specified.

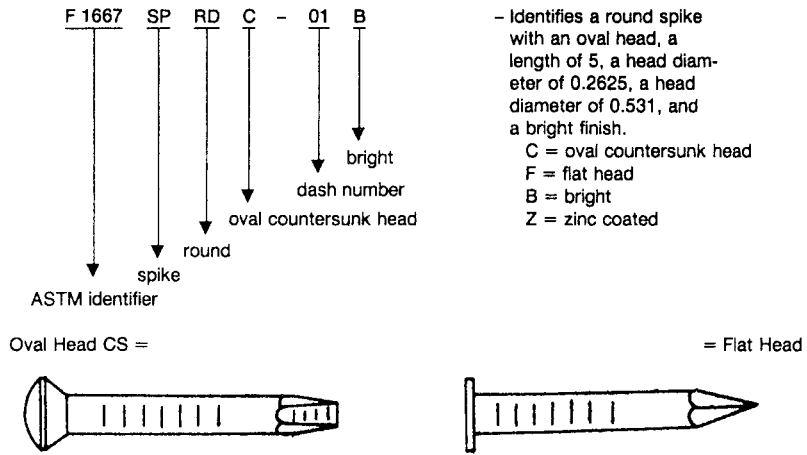

| F 1667 SPRDC | | | | | F 1667 SPRDF | | | |
|--------------|-----|----|--------|-------|--------------|----|-------|-------|
| Dash No. | S | L | D | H | Dash No. | L | D | H |
| 01 | 40d | 5 | 0.2625 | 0.531 | 01 | 8 | 0.312 | 0.625 |
| 02 | 50d | 5½ | 0.283 | 0.562 | 02 | 8 | 0.312 | 0.750 |
| 03 | 60d | 6 | 0.283 | 0.562 | 03 | 9 | 0.312 | 0.750 |
| 04 | ... | 7 | 0.312 | 0.625 | 04 | 10 | 0.312 | 0.750 |

^A All dimensions are given in inches.

ASTM F 1667

TABLE 56 Type III, Style 4—Barge and Boat Spikes^A

NOTE—Wrought iron, hot rolled steel rod or steel wire, square, diamond or oval head, chisel point, bright finish or zinc coated, as specified.

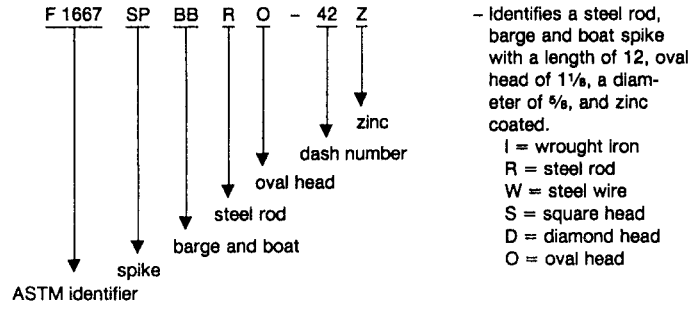

- Identifies a steel rod, barge and boat spike with a length of 12, oval head of 1 1/8, a diameter of 5/8, and zinc coated.
 I = wrought iron
 R = steel rod
 W = steel wire
 S = square head
 D = diamond head
 O = oval head

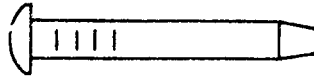

F 1667 SPBB

| Dash No. | D-Square | H | L | Dash No. | D-Square | H | L |
|----------|----------|--------|-------|----------|----------|-------|-----|
| 01 | 1/4 | 17/32 | 3 | 26 | 7/16 | 13/16 | 8 |
| 02 | 1/4 | 17/32 | 3 1/2 | 27 | 7/16 | 13/16 | 9 |
| 03 | 1/4 | 17/32 | 4 | 28 | 7/16 | 13/16 | 10 |
| 04 | 1/4 | 17/32 | 5 | 29 | 7/16 | 13/16 | 11 |
| 05 | 1/4 | 17/32 | 6 | 30 | 7/16 | 13/16 | 12 |
| 06 | 1/4 | 17/32 | 7 | 31 | 1/2 | 1 | 6 |
| 07 | 1/4 | 17/32 | 8 | 32 | 1/2 | 1 | 7 |
| 08 | 5/16 | 19/32 | 3 1/2 | 33 | 1/2 | 1 | 8 |
| 09 | 5/16 | 19/32 | 4 | 34 | 1/2 | 1 | 9 |
| 10 | 5/16 | 19/32 | 5 | 35 | 1/2 | 1 | 10 |
| 11 | 5/16 | 19/32 | 6 | 36 | 1/2 | 1 | 11 |
| 12 | 5/16 | 19/32 | 7 | 37 | 1/2 | 1 | 12 |
| 13 | 5/16 | 19/32 | 8 | 38 | 5/8 | 1 1/8 | 8 |
| 14 | 3/8 | 1 1/16 | 3 | 39 | 5/8 | 1 1/8 | 9 |
| 15 | 3/8 | 1 1/16 | 3 1/2 | 40 | 5/8 | 1 1/8 | 10 |
| 16 | 3/8 | 1 1/16 | 4 | 41 | 5/8 | 1 1/8 | 11 |
| 17 | 3/8 | 1 1/16 | 5 | 42 | 5/8 | 1 1/8 | 12 |
| 18 | 3/8 | 1 1/16 | 6 | ... | ... | ... | ... |
| 19 | 3/8 | 1 1/16 | 7 | ... | ... | ... | ... |
| 20 | 3/8 | 1 1/16 | 8 | ... | ... | ... | ... |
| 21 | 3/8 | 1 1/16 | 9 | ... | ... | ... | ... |
| 22 | 3/8 | 1 1/16 | 10 | ... | ... | ... | ... |
| 23 | 3/8 | 1 1/16 | 11 | ... | ... | ... | ... |
| 24 | 7/16 | 13/16 | 6 | ... | ... | ... | ... |
| 25 | 7/16 | 13/16 | 7 | ... | ... | ... | ... |

^A All dimensions are given in inches.

ASTM F 1667

TABLE 57 Type IV, Style 1—Fence Staples^A

NOTE—Steel wire, bright finish or zinc coated, as specified.

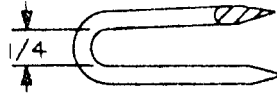
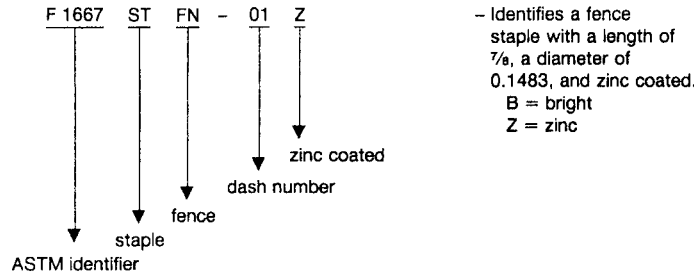

| Dash No. | L | D | No./lb |
|----------|----------------|--------|--------|
| 01 | $\frac{7}{8}$ | 0.1483 | 120 |
| 02 | 1 | 0.1483 | 110 |
| 03 | $1\frac{1}{8}$ | 0.1483 | 97 |
| 04 | $1\frac{1}{4}$ | 0.1483 | 87 |
| 05 | $1\frac{1}{2}$ | 0.1483 | 72 |
| 06 | $1\frac{3}{4}$ | 0.1483 | 61 |

^A All dimensions are given in inches.

TABLE 58 Type IV, Style 2—Poultry Netting Staples^A

NOTE—Steel wire, zinc coated.

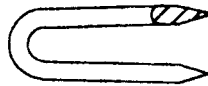
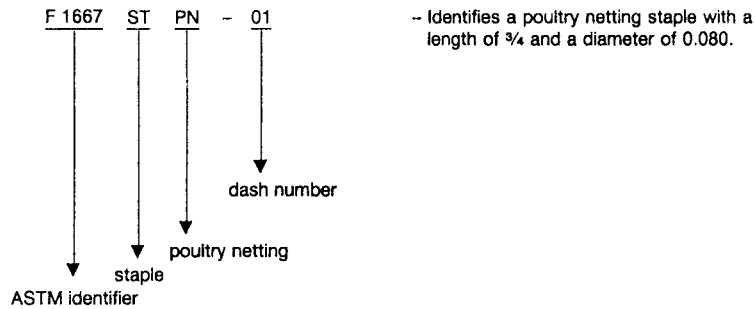

| Dash No. | L | D | No./lb |
|----------|---------------|-------|--------|
| 01 | $\frac{3}{4}$ | 0.080 | 500 |

^A All dimensions are given in inches.

ASTM F 1667

TABLE 59 Type IV, Style 3—Flat Top Crown Staples^A

NOTE—Steel wire, aluminum alloy wire, bright finish, zinc coated, cement coated or chemically etched, as specified. (For use in power tools for fastening wood and other materials to wood.)

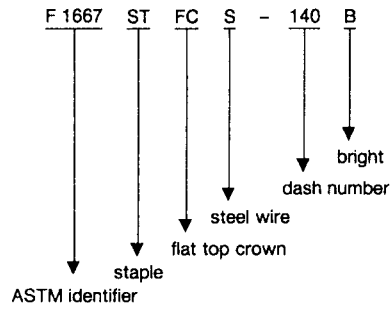

- Identifies a steel wire, flat top crown staple with a crown width of 3/4, a wire gage of 14, a length of 1 1/8, and a bright finish.
- A = aluminum wire
- L = copper-clad wire
- S = steel wire
- B = bright
- Z = zinc coated
- C = cement coated
- E = chemically etched

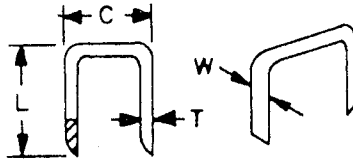

F 1667 STFC

| Dash No. | C | G ^B | L | Dash No. | C | G ^B | L |
|----------|------|----------------|-------|----------|------|----------------|-------|
| 01 | 3/16 | 18 | 3/8 | 51 | 7/16 | 14 | 1 1/2 |
| 02 | 3/16 | 18 | 1/2 | 52 | 7/16 | 14 | 1 5/8 |
| 03 | 3/16 | 18 | 5/8 | 53 | 7/16 | 14 | 1 3/4 |
| 04 | 3/16 | 18 | 3/4 | 54 | 7/16 | 14 | 1 7/8 |
| 05 | 3/16 | 18 | 7/8 | 55 | 7/16 | 14 | 2 |
| 06 | 3/16 | 18 | 1 | 56 | 7/16 | 14 | 2 1/4 |
| 07 | 3/16 | 18 | 1 1/8 | 57 | 7/16 | 14 | 2 1/2 |
| 08 | 3/16 | 18 | 1 1/4 | 58 | 7/16 | 15 | 3/8 |
| 09 | 3/8 | 14 | 3/8 | 59 | 7/16 | 15 | 1/2 |
| 10 | 3/8 | 14 | 1/2 | 60 | 7/16 | 15 | 5/8 |
| 11 | 3/8 | 14 | 5/8 | 61 | 7/16 | 15 | 3/4 |
| 12 | 3/8 | 14 | 3/4 | 62 | 7/16 | 15 | 7/8 |
| 13 | 3/8 | 14 | 7/8 | 63 | 7/16 | 15 | 1 |
| 14 | 3/8 | 14 | 1 1/8 | 64 | 7/16 | 15 | 1 1/8 |
| 15 | 3/8 | 14 | 1 1/4 | 65 | 7/16 | 15 | 1 1/4 |
| 16 | 3/8 | 14 | 1 3/8 | 66 | 7/16 | 15 | 1 3/8 |
| 17 | 3/8 | 14 | 1 1/2 | 67 | 7/16 | 15 | 1 1/2 |
| 18 | 3/8 | 14 | 1 5/8 | 68 | 7/16 | 15 | 1 5/8 |
| 19 | 3/8 | 14 | 1 9/8 | 69 | 7/16 | 15 | 1 3/4 |
| 20 | 3/8 | 16 | 1 3/4 | 70 | 7/16 | 15 | 1 7/8 |
| 21 | 3/8 | 16 | 1/2 | 71 | 7/16 | 15 | 2 |
| 22 | 3/8 | 16 | 5/8 | 72 | 7/16 | 15 | 2 1/4 |
| 23 | 3/8 | 16 | 3/4 | 73 | 7/16 | 15 | 2 1/2 |
| 24 | 3/8 | 16 | 7/8 | 74 | 7/16 | 16 | 3/8 |
| 25 | 3/8 | 16 | 1 1/8 | 75 | 7/16 | 16 | 1/2 |
| 26 | 3/8 | 16 | 1 1/4 | 76 | 7/16 | 16 | 5/8 |
| 27 | 3/8 | 16 | 1 3/8 | 77 | 7/16 | 16 | 3/4 |
| 28 | 3/8 | 16 | 1 1/2 | 78 | 7/16 | 16 | 7/8 |
| 29 | 3/8 | 16 | 1 5/8 | 79 | 7/16 | 16 | 1 |
| 30 | 3/8 | 16 | 1 3/4 | 80 | 7/16 | 16 | 1 1/8 |
| 31 | 3/8 | 18 | 3/8 | 81 | 7/16 | 16 | 1 1/4 |
| 32 | 3/8 | 18 | 1/2 | 82 | 7/16 | 16 | 1 3/8 |
| 33 | 3/8 | 18 | 5/8 | 83 | 7/16 | 16 | 1 1/2 |
| 34 | 3/8 | 18 | 3/4 | 84 | 7/16 | 16 | 1 5/8 |
| 35 | 3/8 | 18 | 7/8 | 85 | 7/16 | 16 | 1 3/4 |
| 36 | 3/8 | 18 | 1 1/8 | 86 | 7/16 | 16 | 1 7/8 |
| 37 | 3/8 | 18 | 1 1/4 | 87 | 7/16 | 16 | 2 |
| 38 | 3/8 | 18 | 1 1/4 | 88 | 7/16 | 16 | 2 1/4 |
| 39 | 3/8 | 18 | 1 1/2 | 89 | 7/16 | 16 | 2 1/2 |
| 40 | 3/8 | 18 | 1 5/8 | 90 | 1/2 | 14 | 1/2 |
| 41 | 3/8 | 18 | 1 3/4 | 91 | 1/2 | 14 | 5/8 |
| 42 | 7/16 | 14 | 3/8 | 92 | 1/2 | 14 | 3/4 |
| 43 | 7/16 | 14 | 1/2 | 93 | 1/2 | 14 | 7/8 |
| 44 | 7/16 | 14 | 5/8 | 94 | 1/2 | 14 | 1 |
| 45 | 7/16 | 14 | 3/4 | 95 | 1/2 | 14 | 1 1/8 |
| 46 | 7/16 | 14 | 7/8 | 96 | 1/2 | 14 | 1 1/4 |
| 47 | 7/16 | 14 | 1 | 97 | 1/2 | 14 | 1 3/8 |
| 48 | 7/16 | 14 | 1 1/8 | 98 | 1/2 | 14 | 1 1/2 |
| 49 | 7/16 | 14 | 1 1/4 | 99 | 1/2 | 14 | 1 5/8 |
| 50 | 7/16 | 14 | 1 3/8 | 100 | 1/2 | 14 | 1 3/4 |

F 1667 STFC

| Dash No. | C | G [#] | L | Dash No. | C | G [#] | L |
|----------|-----|----------------|-------|----------|---------|----------------|-------|
| 101 | 1/2 | 14 | 17/8 | 164 | 7/8 | 14 | 7/8 |
| 102 | 1/2 | 14 | 2 | 165 | 7/8 | 14 | 1 |
| 103 | 1/2 | 14 | 2 1/4 | 166 | 7/8 | 14 | 1 1/8 |
| 104 | 1/2 | 14 | 2 1/2 | 167 | 7/8 | 14 | 1 1/4 |
| 105 | 1/2 | 15 | 1/2 | 168 | 7/8 | 14 | 1 3/8 |
| 106 | 1/2 | 15 | 5/8 | 169 | 7/8 | 14 | 1 1/2 |
| 107 | 1/2 | 15 | 3/4 | 170 | 7/8 | 14 | 1 5/8 |
| 108 | 1/2 | 15 | 7/8 | 171 | 7/8 | 14 | 1 3/4 |
| 109 | 1/2 | 15 | 1 | 172 | 7/8 | 14 | 1 7/8 |
| 110 | 1/2 | 15 | 1 1/8 | 173 | 7/8 | 14 | 2 |
| 111 | 1/2 | 15 | 1 1/4 | 174 | 7/8 | 16 | 1/2 |
| 112 | 1/2 | 15 | 1 3/8 | 175 | 7/8 | 16 | 5/8 |
| 113 | 1/2 | 15 | 1 1/2 | 176 | 7/8 | 16 | 3/4 |
| 114 | 1/2 | 15 | 1 5/8 | 177 | 7/8 | 16 | 7/8 |
| 115 | 1/2 | 15 | 1 3/4 | 178 | 7/8 | 16 | 1 |
| 116 | 1/2 | 15 | 1 7/8 | 179 | 7/8 | 16 | 1 1/8 |
| 117 | 1/2 | 15 | 2 | 180 | 7/8 | 16 | 1 1/4 |
| 118 | 1/2 | 15 | 2 1/4 | 181 | 7/8 | 16 | 1 3/8 |
| 119 | 1/2 | 15 | 2 1/2 | 182 | 7/8 | 16 | 1 1/2 |
| 120 | 1/2 | 16 | 1/2 | 183 | 7/8 | 16 | 1 5/8 |
| 121 | 1/2 | 16 | 5/8 | 184 | 7/8 | 16 | 1 3/4 |
| 122 | 1/2 | 16 | 3/4 | 185 | 7/8 | 16 | 1 7/8 |
| 123 | 1/2 | 16 | 7/8 | 186 | 7/8 | 16 | 2 |
| 124 | 1/2 | 16 | 1 | 187 | 1 1/16 | 14 | 1/2 |
| 125 | 1/2 | 16 | 1 1/8 | 188 | 1 1/16 | 14 | 5/8 |
| 126 | 1/2 | 16 | 1 1/4 | 189 | 1 1/16 | 14 | 3/4 |
| 127 | 1/2 | 16 | 1 3/8 | 190 | 1 1/16 | 14 | 7/8 |
| 128 | 1/2 | 16 | 1 1/2 | 191 | 1 1/16 | 14 | 1 |
| 129 | 1/2 | 16 | 1 5/8 | 192 | 1 1/16 | 14 | 1 1/8 |
| 130 | 1/2 | 16 | 1 3/4 | 193 | 1 1/16 | 14 | 1 1/4 |
| 131 | 1/2 | 16 | 1 7/8 | 194 | 1 1/16 | 14 | 1 3/8 |
| 132 | 1/2 | 16 | 2 | 195 | 1 1/16 | 14 | 1 1/2 |
| 133 | 1/2 | 16 | 2 1/4 | 196 | 1 1/16 | 16 | 1/2 |
| 134 | 1/2 | 16 | 2 1/2 | 197 | 1 1/16 | 16 | 5/8 |
| 135 | 3/4 | 14 | 1/2 | 198 | 1 1/16 | 16 | 3/4 |
| 136 | 3/4 | 14 | 5/8 | 199 | 1 1/16 | 16 | 7/8 |
| 137 | 3/4 | 14 | 3/4 | 200 | 1 1/16 | 16 | 1 |
| 138 | 3/4 | 14 | 7/8 | 201 | 1 1/16 | 16 | 1 1/8 |
| 139 | 3/4 | 14 | 1 | 202 | 1 1/16 | 16 | 1 1/4 |
| 140 | 3/4 | 14 | 1 1/8 | 203 | 1 1/16 | 16 | 1 3/8 |
| 141 | 3/4 | 14 | 1 1/4 | 204 | 1 1/16 | 16 | 1 1/2 |
| 142 | 3/4 | 14 | 1 3/8 | 205 | 1 | 14 | 1/2 |
| 143 | 3/4 | 14 | 1 1/2 | 206 | 1 | 14 | 5/8 |
| 144 | 3/4 | 14 | 1 5/8 | 207 | 1 | 14 | 3/4 |
| 145 | 3/4 | 14 | 1 3/4 | 208 | 1 | 14 | 7/8 |
| 146 | 3/4 | 14 | 1 7/8 | 209 | 1 | 14 | 1 |
| 147 | 3/4 | 14 | 2 | 210 | 1 | 14 | 1 1/8 |
| 148 | 3/4 | 16 | 1/2 | 211 | 1 | 14 | 1 1/4 |
| 149 | 3/4 | 16 | 5/8 | 212 | 1 | 14 | 1 3/8 |
| 150 | 3/4 | 16 | 3/4 | 213 | 1 | 14 | 1 1/2 |
| 151 | 3/4 | 16 | 7/8 | 214 | 1 | 16 | 1/2 |
| 152 | 3/4 | 16 | 1 | 215 | 1 | 16 | 5/8 |
| 153 | 3/4 | 16 | 1 1/8 | 216 | 1 | 16 | 3/4 |
| 154 | 3/4 | 16 | 1 1/4 | 217 | 1 | 16 | 7/8 |
| 155 | 3/4 | 16 | 1 3/8 | 218 | 1 | 16 | 1 |
| 156 | 3/4 | 16 | 1 1/2 | 219 | 1 | 16 | 1 1/8 |
| 157 | 3/4 | 16 | 1 5/8 | 220 | 1 | 16 | 1 1/4 |
| 158 | 3/4 | 16 | 1 3/4 | 221 | 1 | 16 | 1 3/8 |
| 159 | 3/4 | 16 | 1 7/8 | 222 | 1 | 16 | 1 1/2 |
| 160 | 3/4 | 16 | 2 | 223 | 1 3/8 | 12 | 3/4 |
| 161 | 7/8 | 14 | 1/2 | 224 | 1 17/32 | 12 | 3/4 |
| 162 | 7/8 | 14 | 5/8 | 225 | 2 1/8 | 10 | 1 |
| 163 | 7/8 | 14 | 3/4 | ... | ... | ... | ... |

^A All dimensions are given in inches.

^B Dimensions and tolerances for gages of flat top crown staples:

$$18 \text{ Gage (0.0475)} \left[0.0435 \begin{matrix} +0.0040 \\ -0.0060 \end{matrix} T \right] \times \left[0.0475 \begin{matrix} +0.0060 \\ -0.0020 \end{matrix} W \right]$$

$$16 \text{ Gage (0.0625)} \left[0.0570 \begin{matrix} +0.0055 \\ -0.011 \end{matrix} T \right] \times \left[0.0625 \begin{matrix} +0.0075 \\ -0.0025 \end{matrix} W \right]$$

$$15 \text{ Gage (0.0720)} \left[0.0690 \begin{matrix} +0.0030 \\ -0.0086 \end{matrix} T \right] \times \left[0.0720 \begin{matrix} +0.0086 \\ -0.0030 \end{matrix} W \right]$$

$$14 \text{ Gage (0.0800)} \left[0.0775 \begin{matrix} +0.0025 \\ -0.0096 \end{matrix} T \right] \times \left[0.0800 \begin{matrix} +0.0096 \\ -0.0025 \end{matrix} W \right]$$

$$12 \text{ Gage (0.1055)} \left[0.1015 \begin{matrix} +0.0040 \\ -0.0126 \end{matrix} T \right] \times \left[0.1055 \begin{matrix} +0.0126 \\ -0.0040 \end{matrix} W \right]$$

$$10 \text{ Gage (0.1350)} \left[0.1300 \begin{matrix} +0.0050 \\ -0.0162 \end{matrix} T \right] \times \left[0.1350 \begin{matrix} +0.0162 \\ -0.0050 \end{matrix} W \right]$$

ASTM F 1667

TABLE 60 Type IV, Style 3—Flat Top Crown Staples^A

NOTE—Steel wire, chisel point, tin plated, zinc coated or lacquer finish, as specified, cohered together in strips. (For use in staple tackers or machines.) The number per strip shall be as specified and shall be suitable for use in the make and model of tool specified.

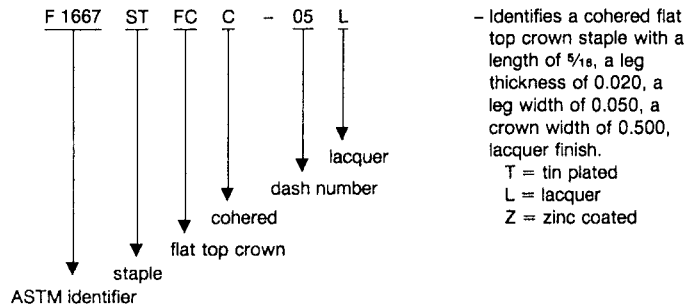

— Identifies a cohered flat top crown staple with a length of $\frac{9}{16}$, a leg thickness of 0.020, a leg width of 0.050, a crown width of 0.500, lacquer finish.
 T = tin plated
 L = lacquer
 Z = zinc coated

| F 1667 STFCC | | | | | | | |
|--------------|----------------|---------------|----------------|----------|----------------|---------------|----------------|
| Dash No. | L | T × W | C ^B | Dash No. | L | T × W | C ^B |
| 01 | $\frac{3}{16}$ | 0.020 × 0.030 | 0.500 | 10 | $\frac{9}{16}$ | 0.020 × 0.050 | 0.437 |
| 02 | $\frac{1}{4}$ | 0.020 × 0.030 | 0.500 | 11 | $\frac{3}{8}$ | 0.030 × 0.050 | 0.164 |
| 03 | $\frac{5}{16}$ | 0.020 × 0.030 | 0.500 | 12 | $\frac{1}{2}$ | 0.030 × 0.050 | 0.164 |
| 04 | $\frac{1}{4}$ | 0.020 × 0.050 | 0.500 | 13 | $\frac{5}{8}$ | 0.030 × 0.050 | 0.164 |
| 05 | $\frac{5}{16}$ | 0.020 × 0.050 | 0.500 | 14 | $\frac{3}{4}$ | 0.030 × 0.050 | 0.164 |
| 06 | $\frac{3}{8}$ | 0.020 × 0.050 | 0.500 | 15 | $\frac{7}{8}$ | 0.030 × 0.050 | 0.164 |
| 07 | $\frac{1}{2}$ | 0.020 × 0.050 | 0.500 | 16 | 1 | 0.030 × 0.050 | 0.164 |
| 08 | $\frac{3}{8}$ | 0.020 × 0.050 | 0.437 | 17 | $1\frac{1}{8}$ | 0.030 × 0.050 | 0.164 |
| 09 | $\frac{1}{2}$ | 0.020 × 0.050 | 0.437 | 18 | $1\frac{1}{4}$ | 0.030 × 0.050 | 0.164 |

^A All dimensions are given in inches.
^B Crown width, C, tolerances: 0.500 ± 0.015, 0.437 ± 0.010, and 0.164 ± 0.015.

TABLE 61 Type IV, Style 4—Round or “V” Crown Staple^A

NOTE—Steel wire or copper-clad wire, bright finish, zinc coated, cement coated or chemically etched, as specified. (For use in power tools for fastening wood and other materials to wood.)

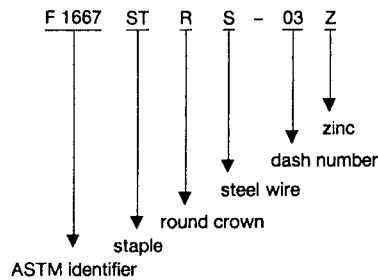

— Identifies a steel round crown staple with a crown width of 0.346, a wire gage of 16, a leg length of $\frac{5}{8}$, zinc coated.
 R = round crown
 V = V-shaped crown
 S = steel wire
 L = copper-clad wire
 B = bright
 C = cement coated
 E = chemical etch
 Z = zinc coated

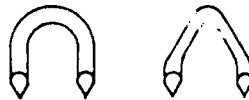

| Dash No. | C ^B | G | L | Dash No. | C ^B | G | L |
|----------|----------------|----|----------------|----------|----------------|----|----------------|
| 01 | 0.346 | 16 | $\frac{1}{2}$ | 07 | 0.435 | 16 | $\frac{1}{2}$ |
| 02 | 0.346 | 16 | $\frac{9}{16}$ | 08 | 0.435 | 16 | $\frac{5}{16}$ |
| 03 | 0.346 | 16 | $\frac{5}{8}$ | 09 | 0.435 | 16 | $\frac{3}{8}$ |
| 04 | 0.346 | 16 | $\frac{3}{4}$ | 10 | 0.435 | 16 | $\frac{1}{2}$ |
| 05 | 0.346 | 16 | $\frac{7}{8}$ | 11 | 0.435 | 16 | $\frac{1}{2}$ |
| 06 | 0.346 | 16 | 1 | 12 | 0.435 | 16 | 1 |

^A All dimensions are given in inches.
^B Crown width tolerances: +0.015 and -0.000.

ASTM F 1667

TABLE 62 Type IV, Style 5—Preformed Staples^A

NOTE—Steel wire, chisel point, zinc or cement coated, as specified. Copper-clad wire, chisel point, tinned or other plated finish, as specified. (Hand driven.)

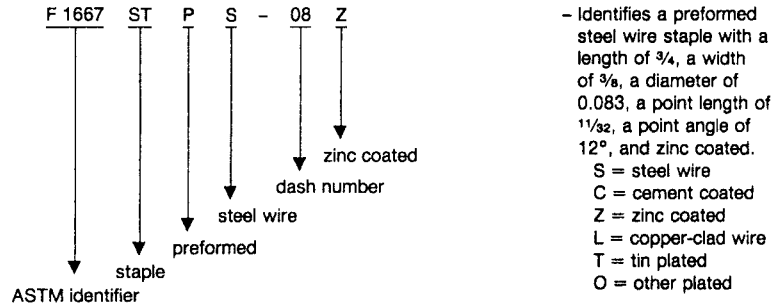

- Identifies a preformed steel wire staple with a length of 3/4, a width of 3/8, a diameter of 0.083, a point length of 11/32, a point angle of 12°, and zinc coated.
 S = steel wire
 C = cement coated
 Z = zinc coated
 L = copper-clad wire
 T = tin plated
 O = other plated



| Dash No. | L | C | D | Flatten | Point Length | Point Angle, ° | No./lb |
|----------|-------|------|-------|---------|--------------|----------------|--------|
| 01 | 3/8 | 7/32 | 0.054 | 0.040 | 3/16 | 13 | 1920 |
| 02 | 13/32 | 3/16 | 0.067 | 0.048 | 3/16 | 12 | 1380 |
| 03 | 7/16 | 7/32 | 0.067 | 0.048 | 1/4 | 12 | 1250 |
| 04 | 1/2 | 1/4 | 0.072 | 0.057 | 1/4 | 12 | 860 |
| 05 | 9/16 | 9/32 | 0.072 | 0.057 | 5/16 | 12 | 800 |
| 06 | 5/8 | 5/16 | 0.072 | 0.057 | 5/16 | 12 | 670 |
| 07 | 11/16 | 3/4 | 0.083 | 0.060 | 11/32 | 12 | 540 |
| 08 | 3/4 | 3/8 | 0.083 | 0.060 | 11/32 | 12 | 410 |

^A All dimensions are given in inches.

TABLE 63 Type IV, Style 6—Electrical Staples^A

NOTE—Insulated or uninsulated, as specified.

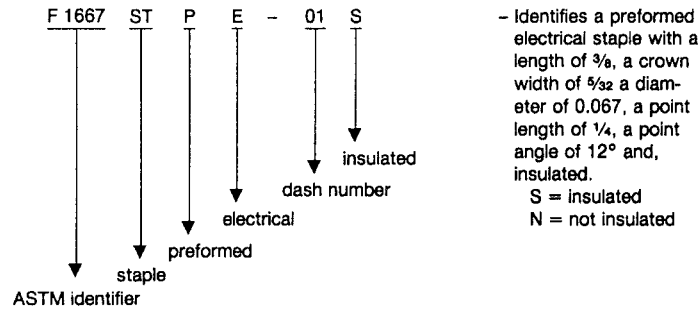

- Identifies a preformed electrical staple with a length of 3/8, a crown width of 5/32, a diameter of 0.067, a point length of 1/4, a point angle of 12° and, insulated.
 S = insulated
 N = not insulated

| Dash No. | L | C | D | Flatten | Point Length | Point Angle | No./lb |
|----------|-------|------|-------|---------------|--------------|-------------|--------|
| 01 | 3/8 | 5/32 | 0.067 | 0.048 | 1/4 | 12 | 1440 |
| 02 | 1/2 | 3/16 | 0.072 | 0.057 | 1/4 | 12 | 990 |
| 03 | 5/8 | 1/4 | 0.072 | 0.057 | 5/16 | 12 | 740 |
| 04 | 3/4 | 3/16 | 0.083 | 0.060 | 11/32 | 12 | 480 |
| 05 | 3/4 | 1/4 | 0.083 | 0.060 | 11/32 | 12 | 450 |
| 06 | 7/8 | 1/4 | 0.083 | 0.060 | 11/32 | 12 | 400 |
| 07 | 7/8 | 7/16 | 0.083 | 0.060 | 11/32 | 12 | 370 |
| 08 | 1 | 1/2 | 0.120 | 0.050 × 0.215 | 3/8 | 18 | ... |
| 09 | 1 1/4 | 5/8 | 0.120 | 0.050 × 0.215 | 3/8 | 18 | ... |

^A All dimensions are given in inches.

TABLE 64 Type IV, Style 7—Preformed Hooped Staple^A

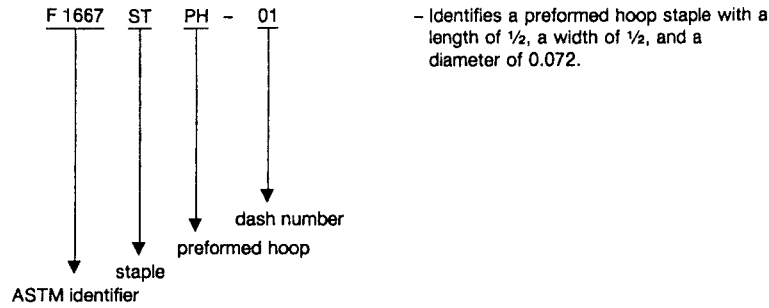

| Dash No. | L | C | D | Flatten | No./lb |
|----------|-----|-------|-------|---------|--------|
| 01 | 1/2 | 1/2 | 0.072 | 0.057 | 720 |
| 02 | 1/2 | 1/2 | 0.083 | 0.060 | 470 |
| 03 | 5/8 | 1/2 | 0.072 | 0.057 | 580 |
| 04 | 5/8 | 1/2 | 0.083 | 0.060 | 430 |
| 05 | 3/4 | 1/2 | 0.072 | 0.057 | 490 |
| 06 | 3/4 | 1/2 | 0.083 | 0.060 | 370 |
| 07 | 1/2 | 5/8 | 0.072 | 0.057 | 670 |
| 08 | 1/2 | 5/8 | 0.083 | 0.060 | 470 |
| 09 | 5/8 | 5/8 | 0.072 | 0.057 | 530 |
| 10 | 5/8 | 5/8 | 0.083 | 0.060 | 400 |
| 11 | 3/4 | 5/8 | 0.072 | 0.057 | 460 |
| 12 | 3/4 | 5/8 | 0.083 | 0.060 | 340 |
| 13 | 1/2 | 3/4 | 0.072 | 0.057 | 580 |
| 14 | 1/2 | 3/4 | 0.083 | 0.060 | 430 |
| 15 | 1/2 | 3/4 | 0.109 | 0.083 | 260 |
| 16 | 5/8 | 3/4 | 0.072 | 0.057 | 490 |
| 17 | 5/8 | 3/4 | 0.083 | 0.060 | 370 |
| 18 | 5/8 | 3/4 | 0.109 | 0.083 | 220 |
| 19 | 3/4 | 3/4 | 0.072 | 0.057 | 430 |
| 20 | 3/4 | 3/4 | 0.083 | 0.060 | 320 |
| 21 | 3/4 | 3/4 | 0.109 | 0.083 | 190 |
| 22 | 1 | 3/4 | 0.072 | 0.057 | 350 |
| 23 | 1 | 3/4 | 0.083 | 0.060 | 260 |
| 24 | 1 | 3/4 | 0.109 | 0.083 | 150 |
| 25 | 1/2 | 7/8 | 0.072 | 0.057 | 530 |
| 26 | 1/2 | 7/8 | 0.083 | 0.060 | 400 |
| 27 | 5/8 | 7/8 | 0.072 | 0.057 | 460 |
| 28 | 5/8 | 7/8 | 0.083 | 0.060 | 340 |
| 29 | 3/4 | 7/8 | 0.072 | 0.057 | 410 |
| 30 | 3/4 | 7/8 | 0.083 | 0.060 | 300 |
| 31 | 7/8 | 7/8 | 0.072 | 0.057 | 360 |
| 32 | 7/8 | 7/8 | 0.083 | 0.060 | 270 |
| 33 | 5/8 | 1 | 0.083 | 0.060 | 320 |
| 34 | 5/8 | 1 | 0.109 | 0.083 | 200 |
| 35 | 3/4 | 1 | 0.083 | 0.060 | 290 |
| 36 | 3/4 | 1 | 0.109 | 0.083 | 180 |
| 37 | 7/8 | 1 | 0.083 | 0.060 | 260 |
| 38 | 7/8 | 1 | 0.109 | 0.083 | 160 |
| 39 | 1 | 1 | 0.083 | 0.060 | 240 |
| 40 | 1 | 1 | 0.109 | 0.083 | 140 |
| 41 | 3/4 | 1 1/4 | 0.083 | 0.060 | 220 |
| 42 | 3/4 | 1 1/4 | 0.109 | 0.083 | 130 |
| 43 | ... | 1 1/4 | 0.083 | 0.060 | 180 |
| 44 | 1 | 1 1/4 | 0.109 | 0.083 | 140 |

^A All dimensions are given in inches.

SUPPLEMENTARY REQUIREMENTS

The following supplementary requirements shall apply only when specified in the order or contract (5.1.7). Details of these supplementary requirements shall be agreed upon in writing between the manufacturer and the purchaser.

S1. Nail Bending Yield Strength

S1.1 When specified as a supplementary requirement for nails used for engineered construction, the nail's average bending yield strengths shall meet, as a minimum, the yield

strengths used in determining the lateral design loads tabulated in the AF&PA National Design Specification⁶ for Wood Construction, NDS,⁶ Part XII: Nails and Spikes.

S1.2 The minimum average bending yield strengths used by the NDS⁶ as a function of the material and diameter of the nail are given in Table S1.1 and Table S1.2.

S1.3 *Test Method for Yield Strength*—In order to conform with the supplementary requirements of S1, the procedure of Test Method F 1575 shall be conducted on nail samples.

S1.4 At least five nails from each lot of 100 individual containers shall be examined and tested to determine conformance with this supplementary requirement.

S1.5 Nails that meet the requirements of this supplementary section, in addition to all other requirements of this specification, shall be labeled on individual packages and shipping

TABLE S1.1 Low to Medium Carbon Steel Nails and Spikes

| Nominal Diameter, in. | Bending Yield, psi |
|-----------------------|--------------------|
| 0.099 ≤ 0.142 | 100 000 |
| >0.142 ≤ 0.177 | 90 000 |
| >0.177 ≤ 0.254 | 80 000 |
| >0.254 ≤ 0.273 | 70 000 |
| >0.273 ≤ 0.344 | 60 000 |
| >0.344 ≤ 0.375 | 45 000 |

TABLE S1.2 Medium Carbon Steel Nails—Hardened

| Nominal Diameter, in. | Bending Yield, psi |
|-----------------------|--------------------|
| 0.120 ≤ 0.142 | 130 000 |
| >0.142 ≤ 0.192 | 115 000 |
| >0.192 ≤ 0.207 | 100 000 |

⁶ Available from American Forest and Paper Association (AF&PA), 1111 19th Street, NW, Suite 800, Washington, DC 20036, *National Design Specification*[®], (NDS[®]), for Wood Construction.

containers as follows: “Engineered Construction Nails, ASTM F 1667.”

The American Society for Testing and Materials takes no position respecting the validity of any patent rights asserted in connection with any item mentioned in this standard. Users of this standard are expressly advised that determination of the validity of any such patent rights, and the risk of infringement of such rights, are entirely their own responsibility.

This standard is subject to revision at any time by the responsible technical committee and must be reviewed every five years and if not revised, either reapproved or withdrawn. Your comments are invited either for revision of this standard or for additional standards and should be addressed to ASTM Headquarters. Your comments will receive careful consideration at a meeting of the responsible technical committee, which you may attend. If you feel that your comments have not received a fair hearing you should make your views known to the ASTM Committee on Standards, at the address shown below.

This standard is copyrighted by ASTM, 100 Barr Harbor Drive, PO Box C700, West Conshohocken, PA 19428-2959, United States. Individual reprints (single or multiple copies) of this standard may be obtained by contacting ASTM at the above address or at 610-832-9585 (phone), 610-832-9555 (fax), or service@astm.org (e-mail); or through the ASTM website (www.astm.org).