



Designation: F 2162 – 01^{ε1}

Standard Specification for Bearing, Roller, Needle: Drawn Outer Ring, Full Complement, Without Inner Ring, Open and Closed End, Standard Type¹

This standard is issued under the fixed designation F 2162; the number immediately following the designation indicates the year of original adoption or, in the case of revision, the year of last revision. A number in parentheses indicates the year of last reapproval. A superscript epsilon (ϵ) indicates an editorial change since the last revision or reapproval.

^{ε1} NOTE—Note 1 was changed editorially in June 2002.

1. Scope

1.1 This specification covers standard-type needle roller bearings having drawn outer rings, full complement, without inner rings, with either open or closed ends.

1.2 The use of recycled materials that meet the requirements of the applicable material specification without jeopardizing the intended use of the item is encouraged.

1.3 The inner rings specified in this specification are not intended for use in flight critical systems of aircraft.

1.4 The values stated in inch-pound units are to be regarded as the standard. The values given in parentheses are provided for information only.

NOTE 1—This specification contains many of the requirements of MS17131, which was originally developed by the Department of Defense and is currently maintained by the Defense Supply Center Richmond.

2. Referenced Documents

2.1 ASTM Standards:

E 18 Test Methods for Rockwell Hardness and Rockwell Superficial Hardness of Metallic Materials²

E 140 Standard Hardness Conversion Tables for Metals (Relationship Among Brinell Hardness, Vickers Hardness, Rockwell Hardness, Rockwell Superficial Hardness, Knoop Hardness, and Scleroscope Hardness)²

E 384 Test Method for Microindentation Hardness²

F 2163 Specification for Ring, Bearing, Inner: for Needle Roller Bearing With Drawn Outer Ring²

2.2 ASME Standard:

ASME B 46.1 Surface Texture Surface Roughness, Waviness, and Lay³

2.3 SAE Standard:

SAE J-404 Chemical Composition of SAE Alloy Steels⁴

2.4 Military Standard:

MIL-STD-130 Identification Marking of US Military Property⁵

2.5 American Bearing Manufacturer's Association (ABMA) Standard:

STD 4 Tolerance Definitions and Gauging Practices For Ball and Roller Bearings⁶

2.6 ISO Standards:

ISO 5593 Rolling Bearings—Vocabulary⁷

ISO 1132 Rolling Bearings—Tolerances—Definitions⁷

3. Terminology

3.1 *Definitions*—For definitions of terms used in this specification, refer to ABMA STD 4 Tolerance Definitions and Gauging Practices for Ball and Roller Bearings, ISO 1132 Roller Bearings—Tolerances—Definitions, and to ISO 5593 Rolling Bearings—Vocabulary

3.2 Definitions of Terms Specific to This Standard:

3.2.1 *average life (L_{50})*, n —for a radial roller bearing, the number of revolutions that 50 % of a group of bearings will complete or exceed before the first evidence of fatigue develops.

3.2.1.1 *Discussion*—The average life maybe as much as five times the rating life.

3.2.2 *basic dynamic load rating (C_r)*, n —for a radial roller bearing, that calculated, constant radial load that a group of apparently identical bearings with stationary outer rings can theoretically endure for a rating life of one million revolutions of the inner ring.

¹ This specification is under the jurisdiction of ASTM Committee F34 on Rolling Element Bearings and is the direct responsibility of Subcommittee F34.01 on Rolling Element.

Current edition approved Dec. 12, 2001. Published March 2002.

² *Annual Book of ASTM Standards*, Vol 03.01.

³ Available from Global Engineering Documents, 15 Inverness Way, East Englewood, CO 80112.

⁴ Available from SAI International, 400 Commonwealth Dr., Warrendale, PA 15096-0001.

⁵ Available from USA Information Systems, 1092 Laskin Rd., Ste. 208, Virginia Beach, VA 23451.

⁶ Available from the American Bearing Manufacturer's Association, 1200 19th St. NW, Ste. 300, Washington, DC 20036-2401.

⁷ Available from ANSI, 1819 L St. NW, Ste. 600, Washington, DC 20036.

3.2.2.1 *Discussion*—Since applied loading as great as the basic dynamic load rating tends to cause local plastic deformation of the rolling surfaces, it is not anticipated that such heavy loading would normally be applied.

3.2.3 *basic static load rating* (C_{or}), n —for a radial roller bearing, that uniformly distributed static radial load which produces a maximum contact stress of 580 000 psi (4000 Mpa) at the center of the contact of the most heavily loaded rolling element.

3.2.3.1 *Discussion*—For this contact stress, total permanent deformation of rolling element and raceway occurs which is approximately 0.0001 or the roller diameter.

3.2.4 *rating life* (L_{10}), n —for a radial roller bearing, the number of revolutions that 90 % of a group of bearings will complete or exceed before the first evidence of fatigue develops.

4. Classification

4.1 This specification covers the following types of roller bearings:

- 4.1.1 *Type B*—Open end roller bearings, and
- 4.1.2 *Type M*—Closed end roller bearings.

5. Ordering Information

5.1 When ordering parts in accordance with this specification, specify the following:

- 5.1.1 ASTM designation number, including year of issue,
- 5.1.2 Type, whether Type B or Type M roller bearings (see Section 4) are to be furnished,
- 5.1.3 Dash number (see Table 1),
- 5.1.4 Dimensions of roller bearings, including:
 - 5.1.4.1 Bore diameter, in;
 - 5.1.4.2 Ring gage diameter, in;
 - 5.1.4.3 Width, in; and
 - 5.1.4.4 Shaft diameter, in;

5.1.5 Load rating, including basic static load rating, lb and basic dynamic load rating, lb;

5.1.6 Approximate limiting speed, rpm; and

5.1.7 Maximum end thickness.

6. Materials and Manufacture

6.1 *Needle Rollers*—Needle rollers shall be manufactured of steel, alloy or carbon, of grades E50100 or E52100 in accordance with SAE AHS STD-66, or 1090 or 1095 in accordance with SAE J-404.

6.2 *Rings*—Rings shall be manufactured of steel, alloy, or carbon, carburizing grade 4620, 4720, 8620, 8720, or 1010-1020 in accordance with SAE AHS STD-66.

7. Other Requirements

7.1 *Heat Treatment*:

7.1.1 *Needle Rollers*—Needle rollers shall be through-hardened to Rockwell HRC58 or equivalent, in accordance with Test Methods E 18.

7.1.2 *Rings*—Rings shall be case hardened to surface hardness of Rockwell HRC58-65 or equivalent, in accordance with Test Methods E 18 with a 0.003 in. minimum case depth.

7.1.2.1 This case depth will not support Rockwell HR15N. Use of a standard file test in accordance with SAE J-864 or microsection and microhardness test in accordance with Test Method E 18 is required to determine the surface hardness.

7.1.3 *Shafts*—Bearings are intended to be used with shafts hardened to Rockwell HRC58-65 in accordance with Test Methods E 18.

7.1.3.1 When an open end bearing is used with an unhardened shaft, the bearing shall be used in conjunction with an inner bearing ring (F 2163).

7.2 *Protective Coating*:

7.2.1 Needle rollers and rings shall be furnished without plating.

7.2.2 Manufacturer shall coat bearings with rust preventive film.

7.3 *Lubrication*—Bearings shall be furnished without lubrication.

7.4 Rollers shall be retained by the outer ring.

7.5 Bearings shall not be furnished with roller separators.

7.6 Oil holes shall be furnished in accordance with the manufacturer's standard practice.

8. Dimensions, Mass, and Permissible Variations

8.1 Products manufactured in accordance with this specification shall meet the requirements shown in Table 1.

8.2 *Plug Gages*—The “go” plug gage is the same size as the minimum diameter under the needle rollers column in Table 1, and the “no go” plug gage size is 0.0001 in. larger than the maximum diameter under the needle rollers column in Table 1. Inspection of the bearing bore shall be made with the bearing pressed into a ring gage of the size shown in the ring gage diameter column of Table 1.

8.3 Bearings are intended to be installed on shafts where maximum deflection does not exceed 0.0010 in. per inch of bearing width.

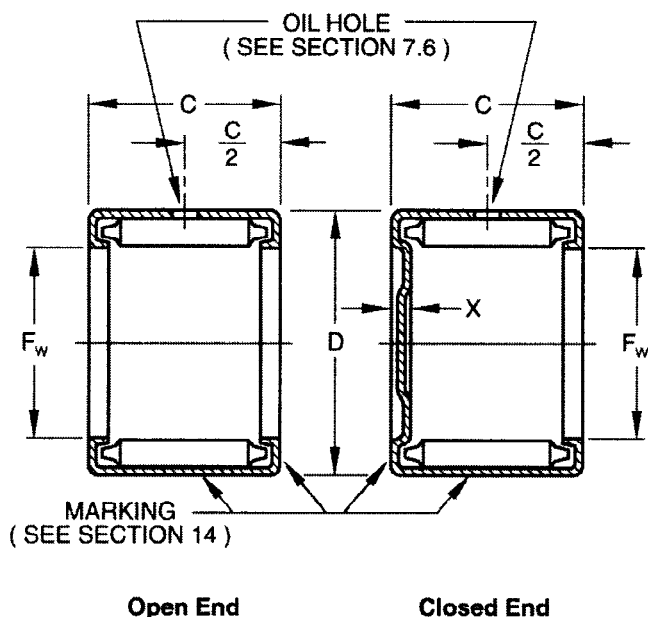

FIG. 1 Schematic Drawing of Type B and Type M Roller Bearings

NOTICE: This standard has either been superseded and replaced by a new version or discontinued. Contact ASTM International (www.astm.org) for the latest information.



TABLE 1 Roller Bearing Dimensions and Tolerances

Dash Number		F _w Bore Diameter, in.			D Diameter, in.		C Width, in.		Shaft Diameter, in.		Basic Static Load Rating, lb	Basic Dynamic Load Rating, lb	Approximate Limiting Speed, rpm	X End Thickness, in., max
Type B	Type M	Nom.	Min.	Max.	Ring Gage	Outside Nom.	+0.000 -0.010	Min.	Max.					
-1	-1M	1/8	0.1258	0.1267	0.2505	1/4	0.250	0.1247	0.1250	221	236	12 500	0.05	
-2	-2M	5/32	0.1571	0.1580	0.2817	9/32	0.312	0.1560	0.1563	387	374	10 700	0.05	
-3	-3M	3/16	0.1883	0.1892	0.3437	11/32	0.250	0.1872	0.1875	283	309	10 700	0.07	
-4	-4M	3/16	0.1883	0.1892	0.3437	11/32	0.375	0.1872	0.1875	575	537	10 700	0.07	
-5	-5M	1/4	0.2515	0.2524	0.4380	7/16	0.312	0.2495	0.2500	482	498	10 000	0.08	
-6	-6M	1/4	0.2515	0.2524	0.4380	7/16	0.438	0.2495	0.2500	865	786	10 000	0.08	
-7	-7M	5/16	0.3140	0.3149	0.5005	1/2	0.312	0.3120	0.3125	578	573	8300	0.08	
-8	-8M	5/16	0.3140	0.3149	0.5005	1/2	0.438	0.3120	0.3125	1040	903	8300	0.08	
-9	-9M	3/8	0.3765	0.3774	0.5630	9/16	0.375	0.3745	0.3750	941	826	7100	0.08	
-10	-10M	3/8	0.3765	0.3774	0.5630	9/16	0.500	0.3745	0.3750	1480	1180	7100	0.08	
-11	-11M	7/16	0.4390	0.4399	0.6255	5/8	0.500	0.4370	0.4375	1690	1280	6300	0.08	
-12	-12M	1/2	0.5015	0.5024	0.6880	11/16	0.375	0.4995	0.5000	1210	968	5500	0.08	
-13	-13M	1/2	0.5015	0.5024	0.6880	11/16	0.500	0.4995	0.5000	1900	1380	5500	0.08	
-14	-14M	1/2	0.5015	0.5024	0.6880	11/16	0.750	0.4995	0.5000	3280	2100	5500	0.08	
-64	-64M	1/2	0.5015	0.5024	0.6880	11/16	0.312	0.4995	0.5000	867	748	5500	0.08	
-65	-65M	1/2	0.5015	0.5024	0.6880	11/16	0.625	0.4995	0.5000	2590	1750	5500	0.08	
-15	-15M	9/16	0.5640	0.5649	0.7505	3/4	0.375	0.5620	0.5625	1340	1030	5000	0.08	
-16	-16M	9/16	0.5640	0.5649	0.7505	3/4	0.500	0.5620	0.5625	2110	1470	5000	0.08	
-17	-17M	9/16	0.5640	0.5649	0.7505	3/4	0.750	0.5620	0.5625	3640	2240	5000	0.08	
-18	-18M	5/8	0.6265	0.6274	0.8130	13/16	0.500	0.6245	0.6250	2320	1560	4500	0.08	
-19	-19M	5/8	0.6265	0.6274	0.8130	13/16	0.750	0.6245	0.6250	4010	2380	4500	0.08	
-66	-66M	5/8	0.6265	0.6274	0.8130	13/16	0.312	0.6245	0.6250	1060	846	4500	0.08	
-67	-67M	5/8	0.6265	0.6274	0.8130	13/16	0.438	0.6245	0.6250	1900	1330	4500	0.08	
-20	-20M	11/16	0.6890	0.6899	0.8755	7/8	0.500	0.6870	0.6875	2530	1640	4200	0.08	
-21	-21M	11/16	0.6890	0.6899	0.8755	7/8	0.750	0.6870	0.6875	4370	2510	4200	0.08	
-22	-22M	3/4	0.7505	0.7514	0.9995	1	0.500	0.7495	0.7500	2630	2000	5300	0.09	
-23	-23M	3/4	0.7505	0.7514	0.9995	1	0.750	0.7495	0.7500	4700	3140	5300	0.09	
-68	-68M	13/16	0.8130	0.8139	1.0620	11/16	0.375	0.8120	0.8125	1710	1410	5200	0.09	
-24	-24M	13/16	0.8130	0.8139	1.0620	11/16	0.500	0.8120	0.8125	2820	2090	5000	0.09	
-25	-25M	13/16	0.8130	0.8139	1.0620	11/16	1.000	0.8120	0.8125	7280	4360	5000	0.09	
-69	-69M	7/8	0.8755	0.8764	1.1245	11/8	0.500	0.8745	0.8750	3020	2170	4800	0.09	
-26	-26M	7/8	0.8755	0.8764	1.1245	11/8	0.750	0.8745	0.8750	5400	3420	4500	0.09	
-27	-27M	7/8	0.8755	0.8764	1.1245	11/8	1.000	0.8745	0.8750	7780	4540	4500	0.09	
-28	-28M	15/16	0.9380	0.9389	1.1870	13/16	1.000	0.9370	0.9375	8280	4720	4400	0.09	
-70	-70M	1	1.0005	1.0014	1.2495	11/4	0.438	0.9995	1.0000	2730	1980	4300	0.09	
-71	-71M	1	1.0005	1.0014	1.2495	11/4	0.500	0.9995	1.0000	3410	2350	4300	0.09	
-29	-29M	1	1.0005	1.0014	1.2495	11/4	0.750	0.9995	1.0000	6100	3690	4100	0.09	
-30	-30M	1	1.0005	1.0014	1.2495	11/4	1.000	0.9995	1.0000	8780	4900	4100	0.09	
-31	-31M	11/16	1.0630	1.0639	1.3120	15/16	0.625	1.0620	1.0625	5020	3140	3800	0.09	
-32	-32M	11/8	1.1255	1.1264	1.3745	13/8	0.750	1.1245	1.1250	6790	3930	3600	0.09	
-33	-33M	11/8	1.1255	1.1264	1.3745	13/8	1.000	1.1245	1.1250	9790	5220	3600	0.09	
-34	-34M	13/16	1.1880	1.1889	1.4995	11/2	0.625	1.1870	1.1875	5100	3430	4400	0.11	
-35	-35M	11/4	1.2505	1.2514	1.4995	11/2	1.000	1.2495	1.2500	10 800	5530	3300	0.09	
-36	-36M	11/4	1.2505	1.2514	1.4995	11/2	1.250	1.2495	1.2500	14 100	6800	3300	0.09	
-37	-37M	15/16	1.3130	1.3140	1.6245	15/8	0.500	1.3120	1.3125	3840	2710	4000	0.11	
-38	-38M	15/16	1.3130	1.3140	1.6245	15/8	0.625	1.3120	1.3125	5590	3630	4000	0.11	
-39	-39M	13/8	1.3755	1.3765	1.6245	15/8	0.750	1.3745	1.3750	8190	4370	3000	0.09	
-40	-40M	13/8	1.3755	1.3765	1.6245	15/8	1.250	1.3745	1.3750	15 400	7140	3000	0.09	
-41	-41M	11/2	1.5005	1.5016	1.8745	17/8	0.625	1.4995	1.5000	6200	4220	4300	0.12	
-42	-42M	11/2	1.5005	1.5016	1.8745	17/8	1.000	1.4995	1.5000	12 300	7170	4300	0.12	
-43	-43M	11/2	1.5005	1.5016	1.8745	17/8	1.250	1.4995	1.5000	16 300	8940	4300	0.12	
-44	-44M	15/8	1.6255	1.6266	1.9995	2	0.625	1.6245	1.6250	6620	4350	3900	0.12	
-44	-44M	15/8	1.6255	1.6266	1.9995	2	0.625	1.6245	1.6250	6620	4350	3900	0.12	
-45	-45M	15/8	1.6255	1.6266	1.9995	2	1.250	1.6245	1.6250	17 500	9260	3900	0.12	
-46	-46M	13/4	1.7505	1.7517	2.1245	21/8	0.750	1.7495	1.7500	9400	5620	3600	0.12	
-47	-47M	13/4	1.7505	1.7517	2.1245	21/8	1.000	1.7495	1.7500	14 000	7880	3600	0.12	
-48	-48M	13/4	1.7505	1.7517	2.1245	21/8	1.500	1.7495	1.7500	23 300	11 400	3600	0.12	
-49	-49M	17/8	1.8755	1.8767	2.2495	21/4	0.500	1.8745	1.8750	5140	3500	3500	0.12	
-50	-50M	17/8	1.8755	1.8767	2.2495	21/4	1.000	1.8745	1.8750	15 000	6080	3500	0.12	
-51	-51M	2	2.0006	2.0018	2.3745	23/8	1.000	1.9994	2.0000	15 900	6300	3300	0.12	
-52	-52M	2	2.0006	2.0018	2.3745	23/8	1.750	1.9994	2.0000	31 700	14 200	3300	0.12	
-72	-72M	21/16	2.0635	2.0649	2.5307	213/32	1.500	2.0619	2.0625	267 000	14 000	4000	0.14	
-53	-53M	21/8	2.1256	2.1270	2.4995	21/2	1.000	2.1244	2.1250	16 800	8510	3000	0.12	
-54	-54M	21/8	2.1256	2.1270	2.4995	21/2	1.500	2.1244	2.1250	28 000	12 600	3000	0.12	
-55	-55M	21/4	2.2506	2.2520	2.6245	25/8	0.750	2.2494	2.2500	12 000	6570	3000	0.13	
-56	-56M	21/4	2.2506	2.2520	2.6245	25/8	1.500	2.2494	2.2500	29 600	13 300	3000	0.13	
-57	-57M	21/2	2.5006	2.5020	2.8795	27/8	1.500	2.4994	2.5000	32 700	13 900	2700	...	
-58	-58M	25/8	2.6260	2.6274	2.9995	3	1.000	2.6244	2.6250	20 600	9570	2500	0.13	
-59	-59M	23/4	2.7510	2.7524	3.1245	31/8	1.000	2.7494	2.7500	21 600	9870	2500	0.13	
-60	-60M	23/4	2.7510	2.7524	3.1245	31/8	1.250	2.7494	2.7500	28 700	12 300	2500	0.13	
-61	-61M	31/2	3.5010	3.5024	3.9995	4	0.750	3.4994	3.5000	16 900	9270	2700	0.15	
-62	-62M	51/2	5.5010	5.5029	5.9990	6	0.750	5.4993	5.5000	25 100	10 800	1600	...	
-63	-63M	71/4	7.2510	7.2530	7.7490	73/4	0.750	7.2490	7.2500	32 700	12 500	1200	...	

8.4 Applications involving oscillating motion often require reduced radial clearances. This reduction is accomplished by increasing the shaft raceway diameters, in inches, as follows:

Increase in Shaft Raceway Diameter	For Bearings with Bore Diameters of
0.0003	$\frac{3}{32}$ – $\frac{3}{16}$
0.0005	$\frac{1}{4}$ – $1\frac{1}{8}$
0.0006	2– $5\frac{1}{2}$

8.5 Steel housing bore diameter dimensions, in inches, are as follows:

Tolerance Applied to Ring Gage Diameter, to Obtain Steel Housing Bore Diameter	For Bearings with Outside Diameters of
+0.0000/–0.0005	$\leq \frac{1}{32}$
+0.0000/–0.0010	$\frac{7}{16}$ – $\frac{7}{8}$
+0.0010/–0.0000	1–5
+0.0020/–0.0000	$\geq 5\frac{1}{16}$

8.6 Mounting in conformance with the shaft diameters and housing bore diameters, in inches, results in the following clearances:

Radial Clearances	For Bearings with Bore Diameters of
0.0003–0.0020	$\leq \frac{3}{16}$
0.0005–0.0029	$\frac{1}{4}$ – $1\frac{1}{4}$
0.0005–0.0030	$1\frac{5}{16}$ – $1\frac{3}{8}$
0.0005–0.0031	$1\frac{1}{2}$ – $1\frac{5}{8}$
0.0005–0.0032	$1\frac{3}{4}$ – $1\frac{7}{8}$
0.0006–0.0034	2
0.0006–0.0036	$2\frac{1}{8}$ – $2\frac{1}{2}$
0.0010–0.0040	$2\frac{3}{8}$ – $3\frac{1}{2}$
0.0010–0.0056	$5\frac{1}{2}$
0.0010–0.0059	$7\frac{1}{4}$

9. Workmanship, Finish and Appearance

9.1 Surface Finish:

9.1.1 *Needle Rollers*—Needle rollers shall have a maximum surface roughness in accordance with ASME B46.1 of 8 μ in. R_a .

9.1.2 *Rings*—The raceway surface (bore) of the outer ring shall have a maximum surface roughness, in accordance with ANSI B46.1, of 20 μ in. R_a .

10. Rating Life of Roller Bearing

10.1 Use the following equation to calculate rating life of roller bearing, L , in millions of revolutions, at loads other than the basic dynamic load ratings:

$$L_{10} = [C_r/P]^{10/3} \quad (1)$$

where:

L_{10} = Rating life, 10^6 revolutions;

C_r = basic dynamic load rating, lb; and
 P = equivalent radial load to which bearing is subjected, lb.

10.1.1 The rating life of roller bearings as calculated in Eq 1 are assumed to be operating under the following conditions:

- 10.1.1.1 The inner ring is rotating,
- 10.1.1.2 The outer ring is stationary,
- 10.1.1.3 The load is steady,
- 10.1.1.4 The revolutions per minute are uniform,
- 10.1.1.5 The roller bearing is thoroughly lubricated,
- 10.1.1.6 The maximum bearing temperature does not exceed 300°F, and

10.1.1.7 Any shaft misalignment does not exceed 0.0010 in. per inch of bearing width.

10.1.2 Eq 1 is not valid for an applied load greater than one-half the basic dynamic load rating.

11. Inspection

11.1 Inspection of the product shall be agreed upon between the purchaser and the supplier as part of the purchase contract.

12. Rejection and Rehearing

12.1 Products that fail to conform to the requirements of this specification may be rejected. Rejection should be reported to the producer or supplier promptly and in writing. In case of dissatisfaction with the results of the test, the producer or supplier may make claim for rehearing.

13. Certification

13.1 When specified in the purchase order or contract, the purchaser shall be furnished certification that samples representing each lot have been either tested or inspected as directed in this specification and the requirements have been met. When specified in the purchase order or contract, a report of the test results shall be furnished.

14. Product Marking

14.1 Marking shall consist of the part number and the manufacturer's identification in accordance with MIL-STD 130.

14.1.1 The part number shall consist of the MS17131 designation number plus the dash number (see Table 1).

15. Keywords

15.1 drawn outer ring; full complement bearing; needle bearing; MS17131; roller bearing

ASTM International takes no position respecting the validity of any patent rights asserted in connection with any item mentioned in this standard. Users of this standard are expressly advised that determination of the validity of any such patent rights, and the risk of infringement of such rights, are entirely their own responsibility.

This standard is subject to revision at any time by the responsible technical committee and must be reviewed every five years and if not revised, either reapproved or withdrawn. Your comments are invited either for revision of this standard or for additional standards and should be addressed to ASTM International Headquarters. Your comments will receive careful consideration at a meeting of the responsible technical committee, which you may attend. If you feel that your comments have not received a fair hearing you should make your views known to the ASTM Committee on Standards, at the address shown below.

This standard is copyrighted by ASTM International, 100 Barr Harbor Drive, PO Box C700, West Conshohocken, PA 19428-2959, United States. Individual reprints (single or multiple copies) of this standard may be obtained by contacting ASTM at the above address or at 610-832-9585 (phone), 610-832-9555 (fax), or service@astm.org (e-mail); or through the ASTM website (www.astm.org).