



## Standard Specification for Stainless Steel Metric Bolts, Screws, and Studs<sup>1</sup>

This standard is issued under the fixed designation F 738M; the number immediately following the designation indicates the year of original adoption or, in the case of revision, the year of last revision. A number in parentheses indicates the year of last reapproval. A superscript epsilon (ε) indicates an editorial change since the last revision or reapproval.

*This standard has been approved for use by agencies of the Department of Defense.*

### 1. Scope

1.1 This specification covers the chemical and mechanical requirements for stainless steel metric bolts, screws, and studs with nominal thread diameters M1.6 through M36, and intended for use in engineering applications requiring general corrosion resistance.

1.2 Eight groups of stainless steel alloys are covered, including three austenitic (Grades A1, A2, and A4), one ferritic (Grade F1), three martensitic (Grades C1, C3, and C4), and one precipitation hardening (Grade P1).

1.3 Twenty property classes are covered, including nine austenitic, two ferritic, eight martensitic, and one precipitation hardening. The property classes with the permissible alloys for each are listed in Table 1.

1.4 This specification is based in concept and content on ISO 3506. The chemical and mechanical requirements specified for all property classes, except as given in 1.4.1, are essentially identical with classes of the same designation in ISO 3506.

1.4.1 This specification includes all of the property classes covered in ISO 3506. Additionally, it includes property classes A1-70, A2-70, A4-70, A1-80, A2-80, and A4-80 for products with nominal thread diameters larger than M20; and four non-ISO property classes, C1-110, C4-110, C3-120; and P1-90.

1.5 Supplementary requirements of an optional nature are provided, applicable only when agreed upon between the manufacturer and the purchaser at the time of the inquiry and order.

1.6 Suitable nuts for use with bolts, screws, and studs included in this specification are covered by Specification F 836M.

1.7 The following safety hazards caveat pertains only to the test method described in this specification. *This standard does not purport to address the safety problems associated with its use. It is the responsibility of the user of this standard to establish appropriate safety and health practices and determine the applicability of regulatory limitations prior to use.*

<sup>1</sup> This specification is under the jurisdiction of ASTM Committee F16 on Fasteners and is the direct responsibility of Subcommittee F16.04 on Nonferrous Fasteners.

Current edition approved Oct. 10, 2000. Published December 2000. Originally published as F 738 – 81. Last previous edition F 738M – 97a.

### 2. Referenced Documents

#### 2.1 ASTM Standards:

- A 276 Specification for Stainless Steel Bars and Shapes<sup>2</sup>
- A 342 Test Methods for Permeability of Feebly Magnetic Materials<sup>3</sup>
- A 380 Practice for Cleaning and Descaling Stainless Steel Parts, Equipment, and Systems<sup>2</sup>
- A 484/A 484M Specification for General Requirements for Stainless Steel Bars, Billets, and Forgings<sup>2</sup>
- A 493 Specification for Stainless and Heat-Resisting Steel Wire and Wire Rods for Cold Heading and Cold Forging<sup>2</sup>
- A 555/A 555M Specification for General Requirements for Stainless and Heat-Resisting Steel Wire and Wire Rods<sup>2</sup>
- A 564/A 564M Specification for Hot-Rolled and Cold-Finished Age-Hardening Stainless and Heat-Resisting Steel Bars and Shapes<sup>4</sup>
- A 582 Specification for Free-Machining Stainless and Heat-Resisting Steel Bars, Hot-Rolled or Cold-Finished<sup>4</sup>
- A 751 Test Methods, Practices, and Terminology for Chemical Analysis of Steel Products<sup>2</sup>
- D 3951 Practice for Commercial Packaging<sup>5</sup>
- E 29 Practice for Using Significant Digits in Test Data to Determine Conformance with Specifications<sup>6</sup>
- E 353 Test Methods for Chemical Analysis of Stainless, Heat-Resisting, Maraging, and Other Similar Chromium-Nickel-Iron Alloys<sup>7</sup>
- F 606M Test Methods for Determining the Mechanical Properties of Externally and Internally Threaded Fasteners, Washers, and Rivets [Metric]<sup>8</sup>
- F 836M Specification for Stainless Steel Metric Nuts<sup>8</sup>
- F 1470 Guide for Fastener Sampling for Specified Mechanical Properties and Performance Inspection<sup>8</sup>

#### 2.2 ISO Standard:

- ISO 3506 Corrosion-Resistant Stainless Steel Fasteners<sup>9</sup>

<sup>2</sup> Annual Book of ASTM Standards, Vol 01.03.

<sup>3</sup> Annual Book of ASTM Standards, Vol 03.04.

<sup>4</sup> Annual Book of ASTM Standards, Vol 01.05.

<sup>5</sup> Annual Book of ASTM Standards, Vol 15.09.

<sup>6</sup> Annual Book of ASTM Standards, Vol 14.02.

<sup>7</sup> Annual Book of ASTM Standards, Vol 03.05.

<sup>8</sup> Annual Book of ASTM Standards, Vol 01.08.

<sup>9</sup> Available from American National Standards Institute, 11 West 42nd Street, 13th Floor, New York, NY 10036.

**TABLE 1 Property Classes of Stainless Steel Bolts, Screws, and Studs**

Property Class	Permissible Alloys
A1-50 A1-70 A1-80	304, 304L, 305 <sup>A</sup> 384, XM7
A2-50 A2-70 A2-80	321, 347
A4-50 A4-70 A4-80	316, 316L
F1-45 F1-60	430 <sup>B</sup>
C1-50 C1-70 C1-110	410
C3-80 C3-120	431
C4-50 C4-70 C4-110	416, 416Se
P1-90	630

<sup>A</sup>When approved by the purchaser, Alloys 303, 303Se, or XM1 may be furnished.

<sup>B</sup>When approved by the purchaser, Alloy 430F may be furnished.

### 3. Classification

3.1 The designation of each property class is comprised of three parts, a letter followed by a single digit, followed by either two or three digits.

3.1.1 The letter indicates the general composition type of stainless steel as follows:

- 3.1.1.1 A for austenitic steels,
- 3.1.1.2 F for ferritic steels,
- 3.1.1.3 C for martensitic steels, and
- 3.1.1.4 P for precipitation-hardening steel.

3.1.2 The first digit (1, 2, 3, or 4) indicates the alloy group. The permissible alloys within each group are given in Table 1.

3.1.3 The last two or three digits (50, 70, 110, etc.) indicate 10 % of the specified minimum tensile strength of the property class.

3.1.4 For example, Class A1-50 is an austenitic steel of any one of seven permitted alloys, and the manufactured fastener has a minimum tensile strength of 500 MPa.

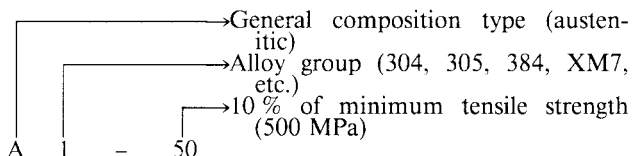

### 4. Ordering Information

4.1 Orders for bolts, screws and studs under this specification shall include the following :

- 4.1.1 Quantity (number of pieces of each item).
- 4.1.2 Name of item (bolt, screw, stud, etc., specific type and style, and reference to dimensional standard when appropriate).

4.1.3 Size (nominal diameter, thread pitch, length).

4.1.4 Property class.

4.1.5 ASTM designation and date of issue. When date of issue is not specified, fasteners shall be furnished to the latest issue.

4.1.6 Supplementary requirements, if any (S1 through S5).

4.1.7 Additional requirements, if any, to be specified on the purchase order:

4.1.7.1 Forming (5.2.1).

4.1.7.2 Threading (5.2.2).

4.1.7.3 Alloy condition (5.2.3).

4.1.7.4 Protective finish (5.2.5).

4.1.7.5 Alloy selection (7.2).

4.1.7.6 Test report (9.2).

4.1.7.7 Heat number (9.1.1).

4.1.7.8 Additional testing (9.3).

4.1.7.9 Inspection (11.1).

4.1.7.10 Rejection (12.1).

4.1.7.11 Certification (13.1).

4.1.7.12 Marking (14.1.3 and 14.1.4).

NOTE 1—*Examples:*

10 000 hex-cap screws, ANSI B18.2.3.1M, M12 × 1.75 × 50, Class A2-70, furnish test report, ASTM F 738, dated \_\_\_\_.

15 000 oval-head machine screws, Type 1 recess, ANSI B18.6.7M, M3 × 0.5 × 25, Class C4-70, 416Se, Supplementary Requirement S2, ASTM F 738, dated \_\_\_\_.

### 5. Materials and Manufacture

5.1 *Materials:*

5.1.1 Specifications A 276, A 493, A 564/A 564M, and A 582/A 582M are noted for information only as suitable sources of material for the manufacture of bolts, hex cap screws, and studs to this specification.

5.2 *Manufacture:*

5.2.1 *Forming*—Unless otherwise specified, fasteners shall be cold-formed, hot-formed, or machined, at the option of the manufacturer.

5.2.2 *Threads*—Unless otherwise specified, threads shall be rolled or cut at the option of the manufacturer.

5.2.3 *Condition*—Fasteners shall be furnished in the condition specified for the property class in Table 2. If other conditions are required, the condition and resultant mechanical properties shall be as agreed upon between the manufacturer and the purchaser.

5.2.4 *Surface Finish*—Fasteners shall have a surface finish produced in accordance with Practice A 380.

5.2.5 *Protective Finishes*—Unless otherwise specified, fasteners shall be furnished without an additive chemical or metallic finish.

### 6. Heat Treatment

6.1 *Austenitic Alloys, Grades A1, A2, and A4*

6.1.1 When Condition AF is specified, the fasteners, following manufacture, shall be annealed by heating to 1040 ± 30°C, at which time the chromium carbide will go into solution. The fasteners shall be held for a sufficient time and then cooled at a rate sufficient to prevent precipitation of the carbide and to provide the properties specified in Table 2.

6.1.2 When Condition CW is specified, the austenitic alloy

**TABLE 2 Mechanical Property Requirements**

Property Class	Condition <sup>A</sup>	Alloy/ Mechanical Property Marking	Nominal Thread Diameter	Product Length <sup>B</sup>	Full Size Product Tests				Machined Specimen Tests			Hardness			
					Tensile Strength, MPa <sup>C</sup>	Yield Strength, MPa <sup>C,D</sup>	Exten- sion <sup>E</sup>	Torsional Strength, N·m <sup>F</sup>	Tensile Strength, MPa	Yield Strength, MPa	Elonga- tion, %	Vickers		Rockwell	
					min	min	min	min	min	min	min	min	max	min	max
A1-50		F 738A	M1.6–M5	all	500	...	...	Table 6	...	...	...	...	165	...	B85
A2-50 A4-50	AF	F 738B F 738C	M6–M36	all	500	210	0.6D	...	500	210	30	...	165	...	B85
A1-70 A2-70 A4-70	CW	F 738D F 738E F 738F	M1.6–M5 M6–M20 over M20–M36	8D 8D 8D	700 700 550	... 450 300	... 0.4D 0.2D x	Table 6 ...	... 650 520	... 400 270	... 20 25	220 220 160	330 330 310	B96 B96 B83	C33 C33 C31
A1-80 A2-80	SH	F 738G F 738H	M1.6–M5 M6–M20 over	8D 8D	800 800 700	... 600 500	... 0.3D 0.2D	Table 6 ...	... 780 680	... 600 480	... 12 15	240 240 220	350 350 330	C23 C23 B96	C36 C36 C33
A4-80		F 738J	M20–M24 over M24–M30 over M30–M36	8D 8D 8D	650 600	400 300	0.2D ...	...	620 570	370 270	20 28	200 180	310 285	B93 B89	C30 C28
F1-45	AF	F 738K	M1.6–M5 M6–M36	all all	450 450	... 250	... 0.2D	...	... 450	... 250	... 25	... ...	165 165	... ...	B85 B85
F1-60	CW	F 738L	M1.6–M5 M6–M36	8D 8D	600 600	... 410	... 0.2D	...	... 550	... 360	... 20	180 180	285 285	B89 B89	C28 C28
C1-50 C4-50	A	F 738M F 738N	M1.6–M5 M6–M36	all all	500 500	... 250	... 0.2D	...	... 500	... 250	... 20	... ...	165 165	... ...	B85 B85
C1-70 C4-70	H	F 738P F 738R	M1.6–M5 M6–M36	all all	700 700	... 410	... 0.2D	...	... 700	... 410	... 18	220 220	330 330	B96 B96	C34 C34
C1-110 C4-110	HT	F 738S F 738T	M1.6–M5 M6–M36	all all	1100 1100	... 820	... 0.2D	...	... 1100	... 820	... 12	350 350	440 440	C36 C36	C45 C45
C3-80	H	F 738U	M1.6–M5 M6–M36	all all	800 800	... 640	... 0.2D	...	... 800	... 640	... 15	240 240	340 340	C23 C23	C35 C35
C3-120	HT	F 738V	M1.6–M5 M6–M36	all all	1200 1200	... 950	... 0.2D	...	... 1200	... 950	... 10	380 380	480 480	C39 C39	C48 C48
P1-90	AH	F 738W	M1.6–M5 M6–M36	all all	900 900	... .700	... 0.2D	...	... 900	... 700	... 16	285 285	370 370	C28 C28	C38 C38

<sup>A</sup> Legend of conditions:

AF — headed and rolled from annealed stock and then reannealed.

CW — headed and rolled from annealed stock, thus acquiring a degree of cold work; products with nominal thread diameters larger than M20 may be hot-worked and solution annealed.

SH — machined from strain-hardened stock or cold worked to develop the specified properties.

A — machined from annealed or solution-annealed stock, thus retaining the properties of the original material.

H — hardened and tempered at 565°C minimum.

HT — hardened and tempered at 275°C minimum.

AH — solution-annealed and age-hardened after forming.

<sup>B</sup> For product lengths:

"all" means all lengths

"8D" means 8 times nominal diameter maximum.

<sup>C</sup> Tensile strength and yield strength values for full-size products of each property class are given in table on yield and tensile strength.

<sup>D</sup> Yield strength is the stress at which an offset of 0.2 % gage length occurs.

<sup>E</sup> Extension measurement is determined in accordance with the test procedure specified in 10.2.3.

<sup>F</sup> Torsional strength requirements apply only to austenitic steel fasteners with nominal thread diameters M5 and smaller. Values are given in table on torsional strength.

shall be annealed as specified in 6.1.1, generally by the raw material manufacturer, and then cold-worked to develop the properties specified in Table 2.

## 6.2 Ferritic Alloys, Grade F1

6.2.1 When Condition AF is specified, the ferritic alloy shall be heated to a temperature of 790 ± 30°C, held for an

appropriate time, and then air-cooled to provide the properties specified in Table 2.

6.2.2 When Condition CW is specified, the ferritic alloy shall be annealed as specified in 6.2.1, generally by the raw material manufacturer and then cold-worked to develop the properties specified in Table 2.

### 6.3 Martensitic Alloys, Grades C1, C3, and C4

6.3.1 When Condition A is specified, the fasteners, following manufacture, shall be annealed to provide the properties specified in Table 2.

6.3.2 When Condition H is specified, the fasteners shall be hardened and tempered by heating to  $1010 \pm 30^\circ\text{C}$  sufficient for austenitization, holding for at least  $\frac{1}{2}$ h, rapid air- or oil-quenching, reheating to  $565^\circ\text{C}$  minimum, and holding for at least 1 h and then air-cooling to provide the properties specified in Table 2.

6.3.3 When Condition HT is specified, the fasteners shall be hardened and tempered by heating to  $1010 \pm 30^\circ\text{C}$  sufficient for austenitization, holding for at least  $\frac{1}{2}$ h, rapid air- or oil-quenching, reheating to  $275^\circ\text{C}$  minimum, and holding for at least 1 h and then air-cooling to provide the properties specified in Table 2.

6.4 *Precipitation-Hardening Alloy, Grade P1*—When Condition AH is specified, the fasteners shall be solution-annealed and aged by heating to  $1040 \pm 15^\circ\text{C}$ , holding for at least  $\frac{1}{2}$ h, rapid air- or oil-quenching to  $27^\circ\text{C}$  maximum, reheating to  $620 \pm 10^\circ\text{C}$  minimum, holding for 4 h, and then air-cooling to provide the properties specified in Table 2.

## 7. Chemical Composition

7.1 It is the intent of this specification that fasteners shall be ordered by property class.

7.2 Unless otherwise specified in the inquiry and purchase order (see Supplementary Requirement S2), when two or more

alloys are permitted for fasteners of a specified property class, the choice of alloy to be used shall be that of the fastener manufacturer as determined by his fastener fabrication methods and material availability. The specific alloy used by the manufacturer shall be clearly identified on any certification required in the purchase order and shall have a chemical composition conforming to the limits specified in Table 3.

7.2.1 When the purchaser specifies that a specific alloy be used, the alloy shall have a chemical composition conforming to the limits specified in Table 3.

7.3 Product analysis may be made by the purchaser from finished fasteners representing each lot. The chemical composition thus determined shall conform to the limits specified in Table 3 for the specific alloy within the product analysis tolerances specified in Specification A 555/A 555M.

7.3.1 In the event of discrepancy, a referee analysis of samples for each lot shall be made in accordance with 9.3.1.

## 8. Mechanical Properties

8.1 Bolts, screws, and studs shall be tested in accordance with the mechanical testing requirements for the applicable product type, property class, nominal thread diameter, length, and specified minimum tensile strength as specified in Table 4, and shall meet the mechanical requirements specified for that product in Tables 2-6.

8.2 For products on which both hardness and tension tests are performed, acceptance based on tensile requirements shall take precedence over low hardness readings.

**TABLE 3 Chemical Requirements**

Alloy Group	Alloy	UNS Designation	Composition, % maximum except as shown									
			Carbon	Manganese	Phosphorus	Sulfur	Silicon	Chromium	Nickel	Copper	Molybdenum	Others
Austenitic Alloys												
A1	303	S30300	0.15	2.00	0.20	0.15 min	1.00	17.0–19.0	8.0–10.0		0.60 max <sup>A</sup>	Se 0.15 min
A1	303Se	S30323	0.15	2.00	0.20	0.060	1.00	17.0–19.0	8.0–10.0			
A1	304	S30400	0.08	2.00	0.045	0.030	1.00	18.0–20.0	8.0–10.5	1.00		
A1	304L	S30403	0.03	2.00	0.045	0.030	1.00	18.0–20.0	8.0–12.0	1.00		
A1	305	S30500	0.12	2.00	0.045	0.030	1.00	17.0–19.0	10.5–13.0	1.00		
A1	384	S38400	0.08	2.00	0.045	0.030	1.00	15.0–17.0	17.0–19.0			
A1	XM1	S20300	0.08	5.0 to 6.5	0.040	0.18 to 0.35	1.00	16.0–18.0	5.0–6.5	1.75–2.25	0.50 max <sup>A</sup>	
A1	XM7	S30430	0.10	2.00	0.045	0.030	1.00	17.0–19.0	8.0–10.0	3.0–4.0		
A4	316	S31600	0.08	2.00	0.045	0.030	1.00	16.0–18.0	10.0–14.0		2.00–3.00	
A4	316L	S31603	0.03	2.00	0.045	0.030	1.00	16.0–18.0	10.0–14.0		2.00–3.00	
A2	321	S32100	0.08	2.00	0.045	0.030	1.00	17.0–19.0	9.0–12.0			Ti 5 × C min
A2	347	S34700	0.08	2.00	0.045	0.030	1.00	17.0–19.0	9.0–13.0			Cb + Ta 10 × C min
Ferritic Alloys												
F1	430	S43000	0.12	1.00	0.040	0.030	1.00	16.0–18.0				
F1	430F	S43020	0.12	1.25	0.060	0.015 min	1.00	16.0–18.0			0.60 max <sup>A</sup>	
Martensitic Alloys												
C1	410	S41000	0.15	1.00	0.040	0.030	1.00	11.5–13.5				
C4	416	S41600	0.15	1.25	0.060	0.15 min	1.00	12.0–14.0			0.60 max <sup>A</sup>	
C4	416Se	S41623	0.15	1.25	0.060	0.060	1.00	12.0–14.0				Se 0.15 min
C3	431	S43100	0.20	1.00	0.040	0.030	1.00	15.0–17.0	1.25–2.50			
Precipitation Hardening Alloy												
P1	630	S17400	0.07	1.00	0.040	0.030	1.00	15.0–17.5	3.0–5.0	3.0–5.0		Cb + Ta 0.15–0.45

<sup>A</sup> At manufacturer's option, determined only when intentionally added.

TABLE 4 Mechanical Testing Requirements for Bolts, Screws, and Studs <sup>A</sup>

Item	Product	Nominal Thread Diameter	Property Class	Specified Tensile Strength of Product, min, kn	Length <sup>B</sup> of Product	Product Hardness		Tests Conducted Using Full-Size Products <sup>C</sup>					Tests Conducted Using Machined Test Specimens			
						max	min	Wedge Tensile Strength	Axial Tensile Strength	Yield Strength	Extension	Torsional Strength	Tensile Strength	Yield Strength	Elongation	
1	Short-length bolts, screws, studs	all	all	all	less than X	M	M	...	...	...	...	...	...	...	...	...
2	Special-head <sup>D</sup> bolts and screws	all	all	all	all	M	M	...	...	...	...	...	...	...	...	...
3	Screws and studs, except Items 1, 2	M1.6–M5	A1, A2, A4	all	X and longer	M	...	...	M	...	...	M	...	...	...	...
4	Screws and studs, except Items 1, 2, 3	M1.6–M5	all	all	X and longer	M	...	...	M	...	...	...	...	...	...	...
5	Bolts and screws with hex or hex flange heads, except Items 1, 2	M6–M36	all	450 and less	X to 8D or 200 mm, whichever is greater	M	...	M	...	M	M	...	...	...	...	...
					over 8D or 200 mm, whichever is greater	M	...	FS	...	FS	FS	...	MS	MS	MS	
6	All other bolts and screws, except Items 1 through 5	M6–M36	all	450 and less	X and longer	M	...	FS	...	FS	FS	...	MS	MS	MS	MS
					X to 8D or 200 mm, whichever is greater	M	...	...	M	M	...	...	...	...	...	
					over 8D or 200 mm, whichever is greater	M	...	...	FS	FS	FS	...	MS	MS	MS	
7	All studs, except Items 1, 3, 4	M6–M36	all	450 and less	X and longer	M	...	...	FS	FS	FS	...	MS	MS	MS	MS
					X to 8D or 200 mm, whichever is greater	M	...	M	...	M	M	...	...	...	...	
					over 8D or 200 mm, whichever is greater	M	...	FS	...	FS	FS	...	MS	MS	MS	
				over 450	X and longer	M	...	FS	...	FS	FS	...	MS	MS	MS	

<sup>A</sup>"M" denotes a mandatory test. For each product, all mandatory tests shall be performed. In addition, either all tests denoted "FS" (which apply to full-size products) or all tests denoted "MS" (which apply to machined test specimens) shall be performed. In case arbitration is necessary, "FS" tests shall be performed. Leaders (. . .) denote tests that are not required.

<sup>B</sup>For values of length X, see Table 6.

<sup>C</sup>Acceptance values for these tests are contained in Table 5.

<sup>D</sup>Special-head bolts and screws are those with special configuration or drilled heads which are weaker than the threaded section.

9. Number of Tests and Retests

9.1 The requirements of this specification shall be met in continuous mass production for stock and the manufacturer shall make sample inspections to ensure that the product conforms to the specified requirements. Additional tests of individual shipments of material are not ordinarily necessary.

9.1.1 Individual heats of steel are not identified in the finished product. When specified in the purchase order that the heat number shall be identified for the products in an individual shipment, the manufacturer shall control the product by heat analysis and additionally shall conduct the testing program specified in 9.3.1.

9.2 When specified in the purchase order, the manufacturer shall furnish a test report certified to be the last complete set of

chemical analysis and mechanical tests for each stock size in each shipment.

9.3 When the purchaser requires that additional tests be performed by the manufacturer to determine that the properties of products in an individual shipment are within specified limits, the purchaser shall specify the testing requirements, including the sampling plan and basis of acceptance, in the inquiry and purchase order.

9.3.1 When the purchaser does not specify the sampling plan and basis of acceptance the following shall apply:

9.3.1.1 The lot, for purposes of selecting samples, shall consist of all products offered for inspection and testing, at one time, that are the same type, style, nominal diameter, thread

TABLE 5 Yield and Tensile Strength Values for Full-Size Fasteners, kN

Nominal Size and Thread Pitch	Stress Area, <sup>A</sup> mm <sup>2</sup>	Yield or Tensile Stress, MPa									
		210	250	300	400	410	450	500	550	600	
M1.6 × 0.35	1.27	...	...	...	...	...	0.57	0.64	...	0.76	
M2 × 0.4	2.07	...	...	...	...	...	0.93	1.04	...	1.24	
M2.5 × 0.45	3.39	...	...	...	...	...	1.52	1.70	...	2.03	
M3 × 0.5	5.03	...	...	...	...	...	2.26	2.52	...	3.02	
M4 × 0.7	8.78	...	...	...	...	...	3.95	4.39	...	5.27	
M5 × 0.8	14.2	...	...	...	...	...	6.39	7.10	...	8.52	
M6 × 1	20.1	4.22	5.03	6.03	8.04	8.24	9.05	10.1	11.1	12.1	
M8 × 1.25	36.6	7.69	9.15	11.0	14.6	15.0	16.5	18.3	20.1	22.0	
M10 × 1.5	58.0	12.2	14.5	17.4	23.2	23.8	26.1	29.0	31.9	34.8	
M12 × 1.75	84.3	17.7	21.1	25.3	33.7	34.6	37.9	42.2	46.4	50.6	
M16 × 2	157	33.0	39.3	47.1	62.8	64.4	70.7	78.5	86.4	94.2	
M20 × 2.5	245	51.5	61.3	73.5	98.0	100	110	123	135	147	
M24 × 3	353	74.1	88.3	106	141	145	159	177	194	212	
M30 × 3.5	561	118	140	168	224	230	252	281	309	337	
M36 × 4	817	172	204	245	327	335	368	409	449	490	

Nominal Size and Thread Pitch	Stress Area, mm <sup>2</sup>	Yield or Tensile Stress, MPa									
		640	650	700	800	820	900	950	1100	1200	
M1.6 × 0.35	1.27	...	...	0.89	1.02	...	...	...	1.40	1.52	
M2 × 0.4	2.07	...	...	1.45	1.66	...	...	...	2.28	2.48	
M2.5 × 0.45	3.39	...	...	2.37	2.71	...	...	...	3.73	4.07	
M3 × 0.5	5.03	...	...	3.52	4.02	...	...	...	5.53	6.04	
M4 × 0.7	8.78	...	...	6.15	7.02	...	...	...	9.66	10.5	
M5 × 0.8	14.2	...	...	9.94	11.4	...	...	...	15.6	17.0	
M6 × 1	20.1	12.9	13.1	14.1	16.1	16.5	18.1	19.1	22.1	24.1	
M8 × 1.25	36.6	23.4	23.8	25.6	29.3	30.0	32.9	34.8	40.3	43.9	
M10 × 1.5	58.0	37.1	37.7	40.6	46.4	47.6	52.2	55.1	63.8	69.6	
M12 × 1.75	84.3	54.0	54.8	59.0	67.4	69.1	75.9	80.1	92.7	101	
M16 × 2	157	100	102	110	126	129	141	149	173	188	
M20 × 2.5	245	157	159	172	196	201	221	233	270	294	
M24 × 3	353	226	229	247	282	289	318	335	388	424	
M30 × 3.5	561	359	365	393	449	460	505	533	617	673	
M36 × 4	817	523	531	572	654	670	735	776	899	980	

<sup>A</sup> Stress area = 0.7854 ( D – 0.9382 P)<sup>2</sup>

where:  
D = nominal size, mm, and  
P = thread pitch, mm.

TABLE 6 Values for Length x<sup>A</sup>

Nominal Thread Diameter	x, mm
M1.6	4
M2	5
M2.5	6
M3	8
M4	10
M5	12
M6	14
M8	20
M10	25
M12	30
M16	40
M20	45
M24 and larger	3D

<sup>A</sup> x equals the minimum length of product subject to tension testing.

pitch, nominal length, material (alloy), property class, and surface finish.

9.3.1.2 From each lot, samples shall be selected at random and tested for each requirement in accordance with the following plan:

Number of Pieces in Lot	Number of Tests	Acceptance Criteria	
		Acceptance Number	Rejection Number

800 and less	1	0	1
801 to 8000	2	0	1
8001 to 22 000	3	0	1
Over 22 000	5	0	1

9.3.1.3 If the failure of a test specimen is due to improper preparation of the specimen or to incorrect testing technique, the specimen shall be discarded and another test specimen substituted.

10. Test Methods

10.1 Chemical Analysis—The chemical composition shall be determined by any recognized commercial test method. In the event of discrepancy, Test Methods E 353 shall be used for referee purposes.

10.2 Mechanical Tests:

10.2.1 Bolts, screws, and studs are to be tested full size as determined by Table 4 for wedge tensile strength, axial tensile strength, yield strength at 0.2 % offset, and hardness in accordance with the methods described in Test Methods F 606M.

10.2.1.1 Test bolts, screws, and studs subject to wedge tension testing using hardened wedges based on the design described in Test Methods F 606M. The wedge shall be 10°

when testing hex bolts and screws of nominal thread diameters M20 and smaller and 6° for sizes larger than M20; 6° when testing studs and hex flange screws of nominal thread diameters M20 and smaller and 4° for sizes larger than M20.

10.2.2 Test machined test specimens tested for tensile strength, yield strength, and elongation in accordance with the methods described in Test Methods F 606M.

10.2.3 *Extension Test*—The extension test is applicable only to full-size products. Measure the overall length of the test specimen ( $L_1$ ). Assemble the specimen into a threaded adapter to a depth of one nominal diameter and then tension-test to failure. Fit the two broken pieces closely together and measure the overall length ( $L_2$ ) again. Compute the total extension by subtracting the original overall length from the length following fracture (Fig. 1). The product is acceptable when the extension equals or exceeds the minimum value for extension specified in Table 2.

10.2.4 *Torsional Strength Test:*

10.2.4.1 Clamp the sample screw or stud securely by suitable means (Fig. 2) such that the threads in the clamped length are not damaged, and that at least two full threads project above the clamping device, and that a length equal to one nominal diameter, exclusive of point is held within the clamping device. A blind hole may be used in place of a threaded-clamping device, provided the hole depth is such as to ensure that breakage will occur beyond the point. By means of a suitably calibrated torque-measuring device, apply torque to the product until failure occurs. The product is acceptable when the torque required to cause failure equals or exceeds the

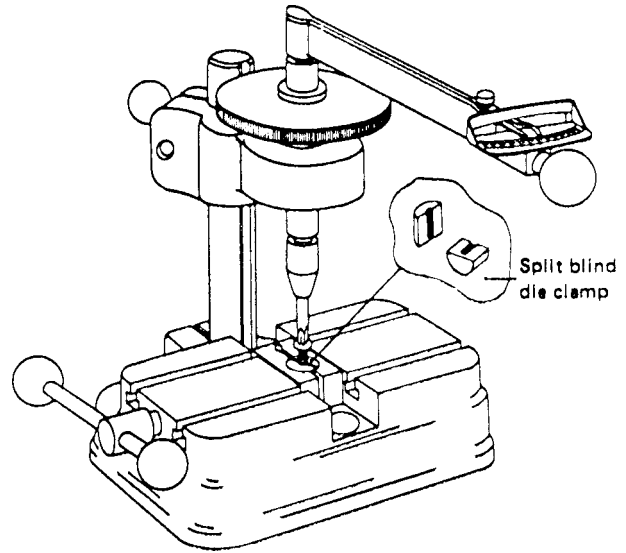

FIG. 2 Torque-Measuring Device

minimum torsional strength specified in Table 7.

10.2.4.2 The calibrated-torque measuring device shall have a measuring range not exceeding five times and an accuracy of  $\pm 7\%$  of the specified minimum torque value (Table 7) of the product being tested.

10.2.5 For the purposes of determining compliance with the specified limits for properties listed in this specification, an observed value or calculated value shall be rounded in accordance with Practice E 29.

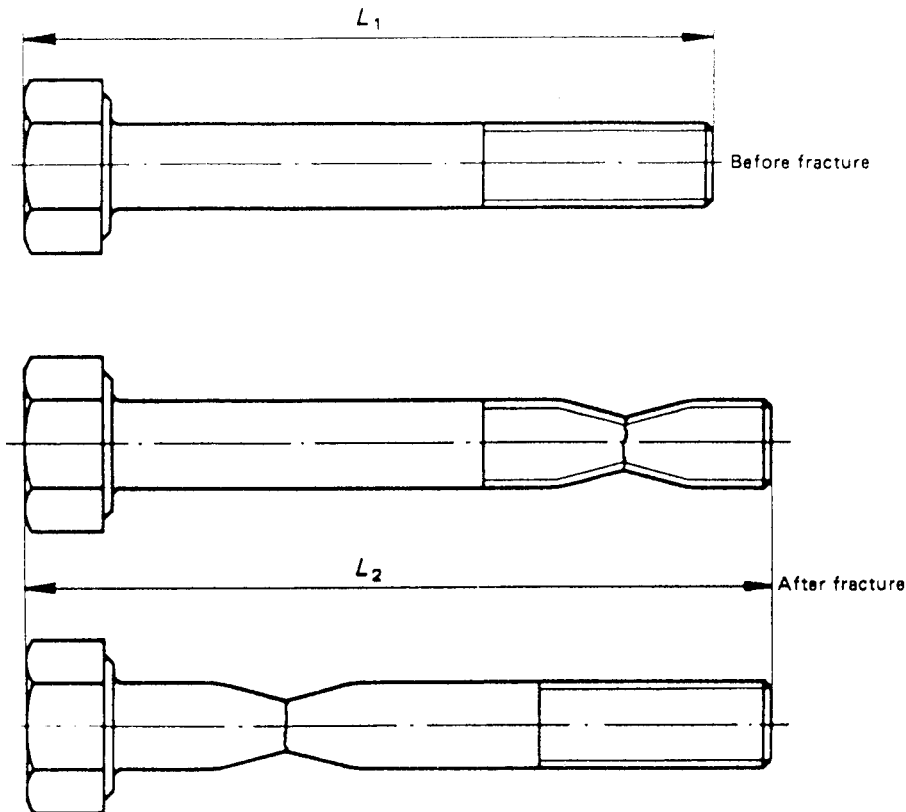

FIG. 1 Test Specimen-Extension Test

**TABLE 7 Torsional Strength<sup>A</sup> of Screws**

0.63 Nominal Size and Thread Pitch	Torsional Strength, min – Grades A1, A2, A4		
	Class 50 N·m	Class 70 N·m	Class 80 N·m
M1.6 × 0.35	0.15	0.20	0.27
M2 × 0.4	0.30	0.40	0.56
M2.5 × 0.45	0.60	0.90	1.20
M3 × 0.5	1.10	1.60	2.10
M3.5 × 0.6	1.80	2.50	3.20
M4 × 0.7	2.70	3.80	4.90
M5 × 0.8	5.50	7.80	10.00

<sup>A</sup> Torsional strength requirements apply only to austenitic steel screws and studs with nominal thread diameters M5 and smaller.

## 11. Inspection

11.1 If the inspection described in 11.2 is required by the purchaser, it shall be specified in the inquiry, order, or contract.

11.2 The inspector representing the purchaser shall have free entry to all parts of the manufacturer's works that concern the manufacture of the material ordered. The manufacturer shall afford the inspector all reasonable facilities to satisfy him that the material is being furnished in accordance with this specification. All tests and inspection required by the specification that are requested by the purchaser's representative shall be made prior to shipment, and shall be so conducted as not to interfere unnecessarily with the operation of the work.

## 12. Rejection and Rehearing

12.1 Unless otherwise specified, any rejection based on tests specified herein and made by the purchaser shall be reported to the manufacturer within 30 working days from the receipt of the product by the purchaser.

## 13. Certification and Test Reports

13.1 *Certificate of Compliance*—Unless otherwise specified in the purchase order, the manufacturer shall furnish certification that the product was manufactured and tested in accordance with the specification and the customer's order, and conforms to all specified requirements.

13.2 *Test Reports*—When specified on the order, the manufacturer shall furnish a test report showing the chemical analysis of the fasteners and the results of the last completed set of mechanical tests for each lot of fasteners in the shipment.

## 14. Product Marking

14.1 *Bolts, Screws, and Studs* :

14.1.1 Unless otherwise specified, bolts and screws of nominal thread diameters smaller than M5, and studs M10 and smaller need not be marked. Additionally, slotted and recessed screws of nominal thread diameters M5 and larger need not be marked.

14.1.2 Bolts and screws of nominal thread diameters M5 and larger, and studs larger than M10 shall be marked with a symbol identifying the manufacturer. In addition, they shall be marked with the alloy/mechanical property marking specified in Table 2. The markings shall be raised or depressed at the option of the manufacturer.

14.1.3 When specified on the purchase order, other studs, bolts, and screws shall be marked. Markings shall be in accordance with 14.1.2 or as otherwise ordered by the purchaser.

14.1.4 Markings shall be located on the top of the head and either be raised or depressed at the option of the manufacturer.

## 15. Packaging and Package Marking

15.1 *Packaging*:

15.1.1 Unless otherwise specified packaging shall be in accordance with Practice D 3951.

15.1.2 When special packaging requirements are required by the purchaser, they shall be defined at the time of inquiry and order.

15.2 *Package Marking*—Each shipping unit shall include or be plainly marked with the following:

15.2.1 ASTM specification,

15.2.2 Alloy number,

15.2.3 Alloy/mechanical property marking,

15.2.4 Size,

15.2.5 Name and brand or trademark of the manufacturer,

15.2.6 Number of pieces,

15.2.7 Country of origin,

15.2.8 Purchase order number, and

15.2.9 Lot number, if applicable.

## 16. Keywords

16.1 bolts; general use; screws; stainless; studs

## SUPPLEMENTARY REQUIREMENTS

One or more of the following supplementary requirements shall apply only when specified by the purchaser in the inquiry and order (4.1.6). Supplementary requirements shall in no way negate any requirement of the specification itself.

### S1. Additional Tests

S1.1 When tests for additional mechanical properties, corrosion resistance, etc., are desired by the purchaser, the test(s) shall be made as agreed upon between the manufacturer and the purchaser at the time of the inquiry or order.

### S2. Alloy Control

S2.1 When Supplementary Requirement S2 is specified on

the inquiry and order, the manufacturer shall supply that alloy specified by the customer on his order with no group substitutions permitted without the written permission of the purchaser.

### S3. Permeability

S3.1 When Supplementary Requirement S3 is specified on the inquiry and order, the permeability of bolts, screws, and



studs of Grades A1, A2, and A4 in Conditions A or AF shall not exceed 1.5 at 100 oersteds when determined by Test Methods A 342.

#### **S4. Passivation**

S4.1 When Supplementary Requirement S4 is specified on the inquiry or order, the finished product shall be passivated in accordance with Specification A 380.

#### **S5. Shipment Lot Testing**

S5.1 When Supplementary Requirement S5 is specified on the order, the manufacturer shall make sample tests on the individual lots for shipment to ensure that the product conforms to the specified requirements.

S5.2 The manufacturer shall make an analysis of a randomly selected finished fastener from each lot of product to be shipped. Heat or lot control shall be maintained. The analysis of the starting material from which the fasteners have been manufactured may be reported in place of the product analysis.

S5.3 The manufacturer shall perform mechanical property tests in accordance with this specification and Guide F 1470 on the individual lots for shipment.

S5.4 The manufacturer shall furnish a test report for each lot in the shipment showing the actual results of the chemical analysis and mechanical property tests performed in accordance with Supplementary Requirement S5.

#### **S6. Heat Control**

S6.1 When Supplementary Requirement S6 is specified on the inquiry or order, the manufacturer shall control the product by heat analysis and identify the finished product in each shipment by the actual heat number or lot number that is heat lot traceable.

S6.2 When Supplementary Requirement S6 is specified on the inquiry and order, Supplementary Requirements S2 and S5 shall be considered automatically invoked with the addition that the heat analysis shall be reported to the purchaser on the test reports.

*The American Society for Testing and Materials takes no position respecting the validity of any patent rights asserted in connection with any item mentioned in this standard. Users of this standard are expressly advised that determination of the validity of any such patent rights, and the risk of infringement of such rights, are entirely their own responsibility.*

*This standard is subject to revision at any time by the responsible technical committee and must be reviewed every five years and if not revised, either reapproved or withdrawn. Your comments are invited either for revision of this standard or for additional standards and should be addressed to ASTM Headquarters. Your comments will receive careful consideration at a meeting of the responsible technical committee, which you may attend. If you feel that your comments have not received a fair hearing you should make your views known to the ASTM Committee on Standards, at the address shown below.*

*This standard is copyrighted by ASTM, 100 Barr Harbor Drive, PO Box C700, West Conshohocken, PA 19428-2959, United States. Individual reprints (single or multiple copies) of this standard may be obtained by contacting ASTM at the above address or at 610-832-9585 (phone), 610-832-9555 (fax), or [service@astm.org](mailto:service@astm.org) (e-mail); or through the ASTM website ([www.astm.org](http://www.astm.org)).*