



Standard Specification for Surface Discontinuities of Bolts, Screws, and Studs, Inch and Metric Series¹

This standard is issued under the fixed designation F 788/F 788M; the number immediately following the designation indicates the year of original adoption or, in the case of revision, the year of last revision. A number in parentheses indicates the year of last reappraisal. A superscript epsilon (ε) indicates an editorial change since the last revision or reappraisal.

This standard has been approved for use by agencies of the Department of Defense.

1. Scope*

1.1 This specification establishes allowable limits for the various types of surface discontinuities that may occur during the manufacture and processing of bolts, screws, and studs, including heat-treated machine screws, tapping screws, and sems (the washers of screw-washer assemblies are excluded). This specification covers metric series products with nominal diameters of 4 mm and larger and with specified minimum tensile strengths of 800 MPa and greater; and inch series products with nominal diameters of No. 5 (0.1250 in.) and larger and with specified minimum tensile strengths of 90 000 psi and greater.

1.2 The values stated in either SI (metric) or inch-pound units are to be regarded separately as standard. The values stated in each system are not exact equivalents, therefore, each system must be used independently of the other. Combining values from the two systems may result in nonconformance with the specification.

1.3 When the engineering requirements of the application necessitate control of surface discontinuities on bolts, screws, or studs, the purchaser shall specify conformance to ASTM Specification F 788/F 788M, in the original inquiry and purchase order.

1.3.1 When the engineering requirements of the application necessitate that surface discontinuities on bolts, screws, and studs be controlled within limits closer than those specified in this specification, the purchaser shall specify the applicable limits in the original inquiry and purchase order.

1.4 The allowable limits established in this specification for metric bolts, screws, and studs with nominal diameters from 4 to 24 mm inclusive, are essentially identical with requirements given in ISO 6157/I. There are no ISO standards for surface discontinuities on any inch-series products.

2. Referenced Documents

2.1 ASTM Standards:

- E 340 Test Method for Macroetching Metals and Alloys²
- F 1470 Standard Guide for Fastener Sampling for Specified Mechanical Properties and Performance Inspection³
- F 1789 Standard Terminology for F16 Mechanical Fasteners³

2.2 ISO Standard:⁴

- ISO 6157/I Fasteners, Surface Discontinuities on Bolts, Screws and Studs

3. Ordering Information

3.1 Orders for bolts, screws, and studs requiring discontinuity control shall include the following:

3.1.1 ASTM designation and date of issue of this specification.

3.1.2 Special requirements, for example, closer discontinuity limits (1.3.1) and inspection sampling plan (6.2).

4. Types of Surface Discontinuities (see Terminology F 1789 for definitions not provided)

4.1 Crack

4.1.1 *Quench Cracks*—Typical quench cracks are shown in Fig. 1. Limits are specified in 5.2.

4.1.2 *Forging Cracks*—Typical forging cracks are shown in Fig. 2. Limits are specified in 5.3.

4.2 *Burst*—Typical bursts are shown in Fig. 3. Limits are specified in 5.4.

4.2.1 *Shear Burst*—A shear burst is an open break in the metal located at approximately a 45° angle to the product axis. Shear bursts occur most frequently at the periphery of products having flanged or circular heads. Shear bursts may also occur on the sides of hex-head products. Typical shear bursts are shown in Fig. 3. Limits are specified in 5.4.

¹ This specification is under the jurisdiction of ASTM Committee F16 on Fasteners and is the direct responsibility of Subcommittee F16.93 on Quality Assurance Provisions for Fasteners.

Current edition approved July 10, 2002. Published August 2002. Originally published as F 788/F 788M – 82. Last previous edition F 788/F 788M – 97.

² *Annual Book of ASTM Standards*, Vol 03.01.

³ *Annual Book of ASTM Standards*, Vol 01.08.

⁴ Available from American National Standards Institute, 11 West 42nd Street, 13th Floor, New York, NY 10036.

*A Summary of Changes section appears at the end of this standard.

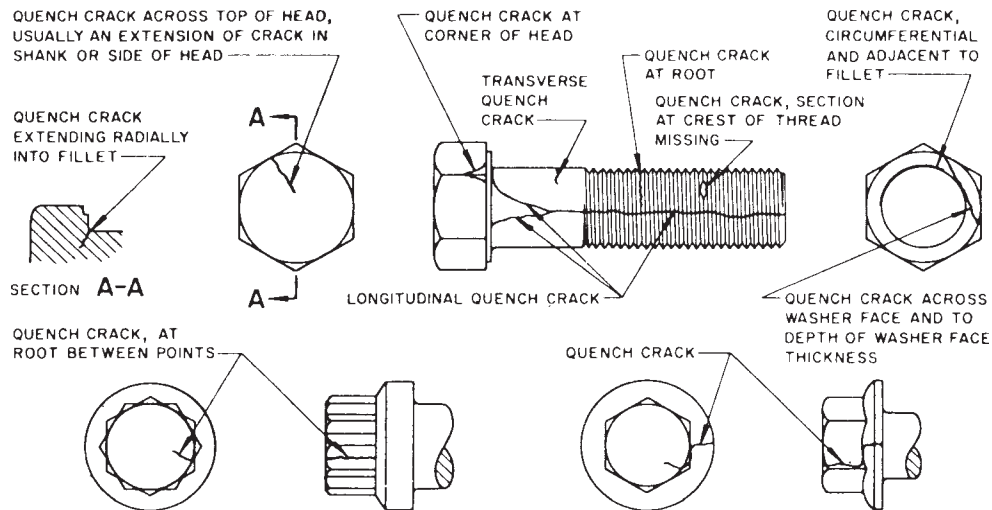

FIG. 1 Typical Quench Cracks

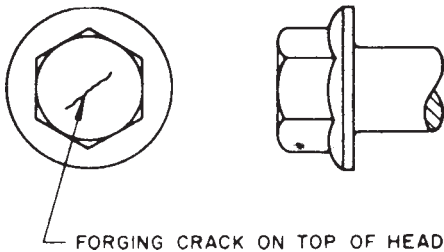

FIG. 2 Typical Forging Cracks

4.3 *Seam*—Typical seams are shown in Fig. 4. Limits are specified in 5.5.

4.4 *Fold*—Typical folds are shown in Fig. 5 *a*, *b*, and *c*. Limits are specified in 5.6.

4.5 *Thread Lap*—Limits are specified in Supplementary Requirement S.1.1.

4.6 *Void*—A void is a shallow pocket or hollow on the surface of a bolt or screw due to nonfilling of metal during forging. Voids are produced by marks or impressions of chips (shear burrs) or by rust formation on the raw material. They are not planished during forging. Typical voids are shown in Fig. 6. Limits are specified in 5.7.

4.7 *Tool Marks*—Tool marks are longitudinal or circumferential grooves of shallow depth produced by the movement of manufacturing tools over the surface of the bolt or screw. Typical tool marks are shown in Fig. 7. Limits are specified in 5.8.

4.8 *Gouge*—A gouge is an indentation on the surface of a bolt, screw, or stud produced by the forceful abrasion or the impact of a product coming into contact with another product or manufacturing equipment during manufacture, handling, or transport. Limits are specified in 5.9.

5. Allowable Limits

5.1 *Letter Definitions*—Throughout the following requirements, *D* designates the nominal size (basic major diameter of thread) of bolts, screws, and studs, except for products with shoulders, in which case *D* designates the largest shoulder diameter; and *D_c* designates flange diameter (specified maxi-

mum) or head diameter (specified maximum) of circular head products. For metric series products, *D* and *D_c* are in millimetres; for inch-series products, *D* and *D_c* are in inches.

5.2 *Quench Cracks*—Quench cracks of any depth, any length, or in any location are not permitted.

5.3 *Forging Cracks*—Forging cracks on the top of the head of bolts and screws are permitted, provided that (a) no crack shall have a length exceeding $1.0 D$, and (b) no crack shall have a width or depth exceeding $0.04 D$.

5.4 Bursts and Shear Bursts:

5.4.1 For hex-head bolts and screws, bursts and shear bursts are permitted, provided that (a) no burst or shear burst in the flats extends into the crown (chamfer) circle on the top of the head or into the underhead bearing circle, (b) no burst or shear burst located at the intersection of two wrenching flats reduces the width across corners below its specified minimum, and (c) no burst or shear burst has a width or depth greater than $.06D$ but not to exceed $.062$ in. (1.6 mm).

5.4.2 For flange bolts and screws and products with circular heads, bursts and shear bursts at the periphery of the flange or head are permitted, provided that (a) not more than one burst or shear burst has a width greater than $0.04 D_c$ and (b) the width of the one burst or shear burst that exceeds a width of $0.04 D_c$ does not have a width greater than $0.08 D_c$.

5.4.3 For indented head bolts and screws, bursts and shear bursts in the raised periphery of the indented head are permitted, provided that (a) no burst or shear burst has a width greater than $0.06 D$ and (b) no burst or shear burst has a depth extending below the indented portion.

5.5 Seams:

5.5.1 Seams in the shanks of bolts, screws, and studs are permitted provided that no seam has a depth greater than $0.03 D$.

5.5.2 Seams extending into the heads and flanges of bolts and screws are permitted, provided that they do not open beyond the limits specified for bursts and shear bursts in 5.4.

5.6 Folds:

5.6.1 Folds located at interior corners that are at or below the underhead bearing surface, for example, at the junction of head to shank, are not permitted, except for cloverleaf folds

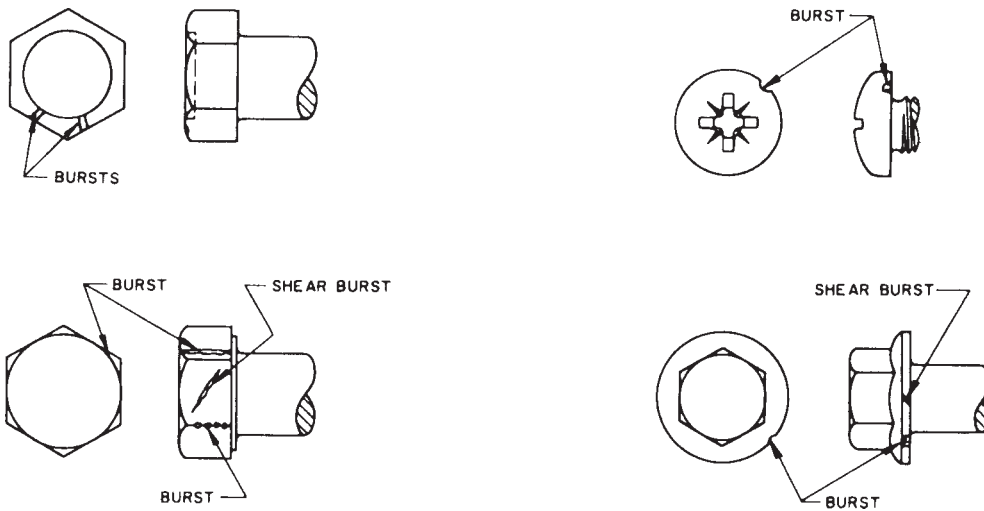

FIG. 3 Typical Bursts and Shear Bursts

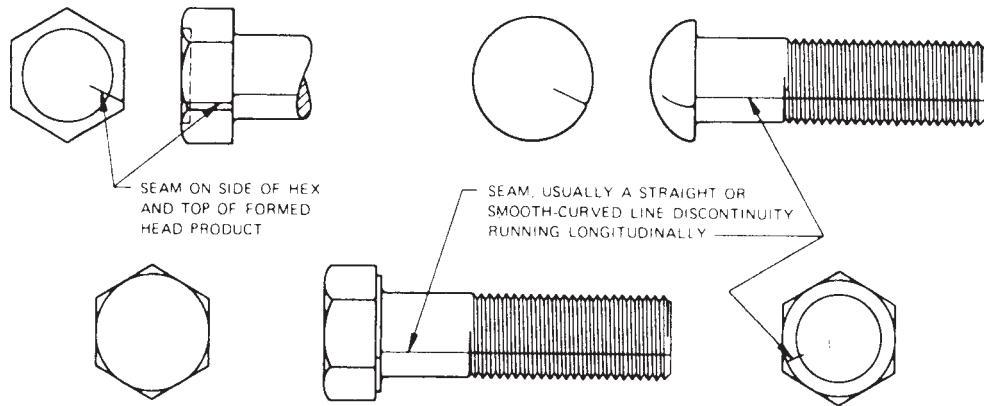

FIG. 4 Typical Seams

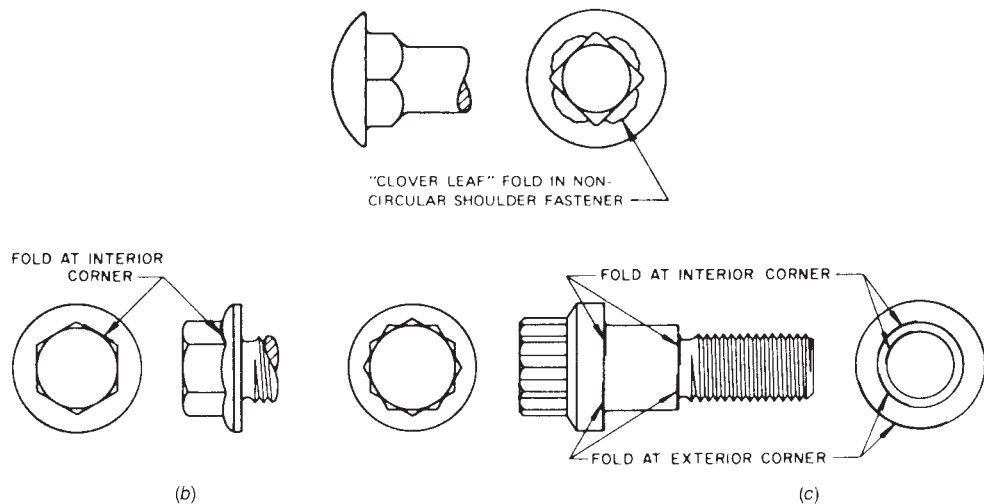

FIG. 5 Typical Folds

occurring at the intersection of non-circular shoulders with head bearing face (see Fig. 5a).

5.6.2 Folds located at interior corners that are above the underhead bearing surface, for example, at the junction of the hex head with the top of flange of flange bolts and screws, are permitted (see Fig. 5b).

5.6.3 Folds located at exterior corners are permitted (see Fig. 5c).

5.7 Voids:

5.7.1 Voids on the surfaces of bolts, screws, and studs are permitted, provided that (a) depth of voids does not exceed 0.25 mm or 0.010 in. or 0.02 D, whichever is greater, and (b)

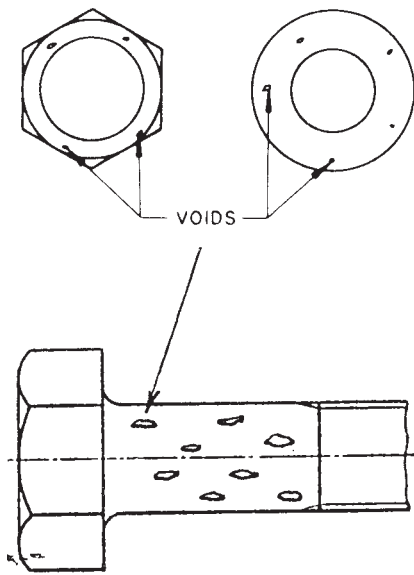

FIG. 6 Typical Voids

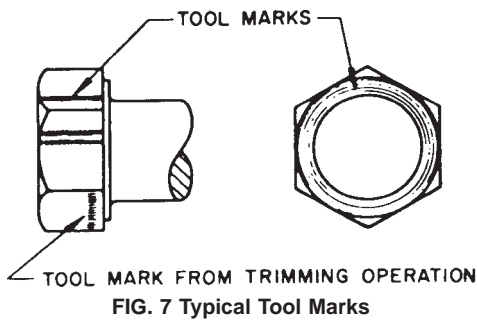

FIG. 7 Typical Tool Marks

the combined area of all voids on the underhead bearing surface of bolts and screws does not exceed 10 % of the specified minimum bearing surface area.

5.7.2 The method for determining the area of voids on the bearing surface shall be as agreed upon between the purchaser and the producer.

5.8 Tool Marks:

5.8.1 Tool marks on the underhead bearing surface are permitted, provided the surface roughness measurement does

not exceed 3.2 μm or 125 $\mu\text{in.}$, determined as the arithmetic average deviation from the mean surface.

5.8.2 Tool marks on other surfaces of the product are permitted.

5.9 Nicks and Gouges—Nicks, gouges, dents, and scrapes are permitted, provided that the functionality of the product is not impaired.

6. Inspection and Evaluation

6.1 Bolts, screws, and studs shall be inspected for surface discontinuities in accordance with the procedure in 6.2, 6.3, and 6.4.

6.2 The purchaser shall specify in the original inquiry and purchase order the inspection sampling requirements that the producer must satisfy to demonstrate the acceptability of bolts, screws, and studs with respect to surface discontinuities.

6.3 In the absence of purchaser instructions (6.2), inspection and evaluation shall be in accordance with 6.5.

6.4 For referee purposes, unless other procedures have been specified by the purchaser (6.2), inspection and evaluation shall be in accordance with 6.5.

6.5 Inspection Procedure:

6.5.1 Visual Inspection:

6.5.1.1 A random sample shall be taken from the lot in accordance with F 1470 and examined visually (magnetic particle or fluid penetrant are recommended) for the presence of quench cracks, forging cracks, bursts, shear bursts, seams, folds, voids, tool marks, and nicks and gouges. Visual inspection can include the use of devices that provide up to, and including, 10-power magnification.

6.5.1.2 If, during this inspection, any products are found with quench cracks in any location or with folds at interior corners that are at or below the underhead bearing surface, the lot may be rejected by the purchaser.

6.5.1.3 If, during this inspection, any products are found with any other surface discontinuity, each discontinuity shall be measured, and if any is found that exceeds the allowable dimensional limits for that discontinuity as specified in Section 5, the lot may be rejected by the purchaser.

7. Keywords

7.1 bolts; crack; discontinuities (surface); fold; screw (machine, sems, tapping); seam; studs; thread lap; void

SUPPLEMENTARY REQUIREMENTS

One or more of the following supplementary requirements shall apply only when specified by the purchaser in the inquiry and order. Supplementary Requirements shall in no way negate any requirement of the specification itself.

S1. Assemblies Subject to Severe Dynamic Stresses

S1.1 Laps in Screw Threads:

S1.1.1 Laps of any depth and any length which originate below (or originating above and extending below) a point located at a distance equal to or less than 20 % of the thread height, measured from the minor diameter, are not permitted. See 4.5 and the Fig. S1.1 and Fig. S1.2.

S1.1.2 Surface discontinuities of threads caused by the thread rolling process, as in Fig. S1.2, shall be excluded from these requirements provided the discontinuities do not exceed the depth of 0.5 % \times nominal diameter and are essentially parallel to the adjacent thread contour and are not directed toward the screw or bolt axis.

S1.2 Thread Lap Inspection:

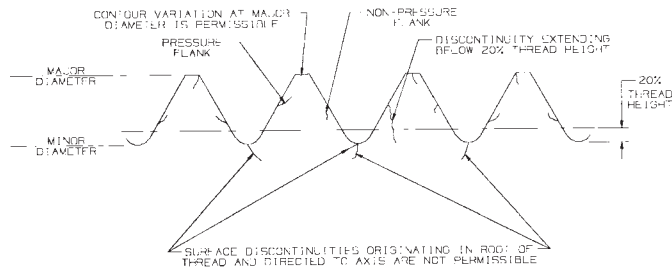
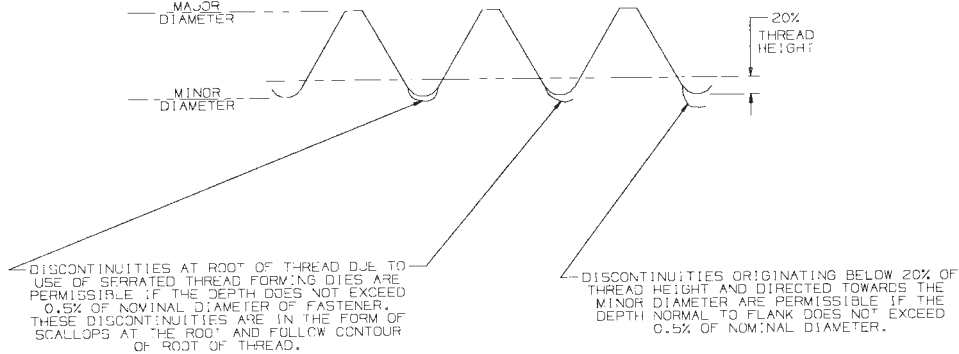

FIG. S1.1 Typical Thread Laps



NOTE 1—Laps which originate below (or originate above and extend below) 20 % thread height are not permissible discontinuities except as shown in Fig. S1.2.

FIG. S1.2 Typical Starting Serrations

S1.2.1 *Visual Inspection*—A random sample shall be selected from the lot in accordance with F 1470. The sample selected shall be surface etched in a 50 % solution of HCl and H₂O at approximately 180°F (no more than 5 min of etch time should be employed as excessive etching may remove shallow thread laps). After etch, the samples shall be examined under a 10 × magnification for the presence of laps.

S1.2.2 *Microscopic Examination*—If laps are present, one of the samples shall be sectioned longitudinally on the center line of the bolt/screw and on a plane passing through the point at which any lap extends closest to the minor diameter of the thread. The section shall be etched for microscopic examination in accordance with Test Method E 340. Acceptance shall be based on the requirements of S1.1.

SUMMARY OF CHANGES

This section identifies the location of selected changes to this specification that have been incorporated since the -97 issue. For the convenience of the user, Committee F16 has highlighted those changes that may impact the use of this specification. This section may also include descriptions of those changes or reasons for the changes, or both.

- (1) In 2.1, added Guide F 1470 and Terminology F 1789.
- (2) In 4, added reference to Terminology F 1789.
- (3) Revised 4.1, 4.1.1, 4.1.2, 4.1.3, 4.2, 4.3, 4.4, 4.5, and 4.8.
- (4) In 6.5.1.1, removed reference to Table 1 and added reference to Guide F 1470.
- (5) Deleted Table 1.



F 788/F 788M – 02

ASTM International takes no position respecting the validity of any patent rights asserted in connection with any item mentioned in this standard. Users of this standard are expressly advised that determination of the validity of any such patent rights, and the risk of infringement of such rights, are entirely their own responsibility.

This standard is subject to revision at any time by the responsible technical committee and must be reviewed every five years and if not revised, either reapproved or withdrawn. Your comments are invited either for revision of this standard or for additional standards and should be addressed to ASTM International Headquarters. Your comments will receive careful consideration at a meeting of the responsible technical committee, which you may attend. If you feel that your comments have not received a fair hearing you should make your views known to the ASTM Committee on Standards, at the address shown below.

This standard is copyrighted by ASTM International, 100 Barr Harbor Drive, PO Box C700, West Conshohocken, PA 19428-2959, United States. Individual reprints (single or multiple copies) of this standard may be obtained by contacting ASTM at the above address or at 610-832-9585 (phone), 610-832-9555 (fax), or service@astm.org (e-mail); or through the ASTM website (www.astm.org).