



Standard Specification for Alloy Steel Socket Button and Flat Countersunk Head Cap Screws¹

This standard is issued under the fixed designation F 835; the number immediately following the designation indicates the year of original adoption or, in the case of revision, the year of last revision. A number in parentheses indicates the year of last reapproval. A superscript epsilon (ϵ) indicates an editorial change since the last revision or reapproval.

This standard has been approved for use by agencies of the Department of Defense.

1. Scope *

1.1 This specification covers the requirements for quenched and tempered alloy steel hexagon socket button (SBHCS) 0.060 through 0.625 thread sizes and flat countersunk (SFHCS) 0.060 through 1.5 thread sizes head cap screws having material properties for high-strength requirements.

1.2 Fasteners meeting this specification are intended for shear-type applications and have tensile requirements ranging from 122 to 150 ksi.

1.3 The hazard statement applies only to the test method section, Section 11, of this specification. *This standard does not purport to address all of the safety concerns, if any, associated with its use. It is the responsibility of the user of this standard to establish appropriate safety and health practices and determine the applicability of regulatory limitations prior to use.*

2. Referenced Documents

2.1 ASTM Standards:

- A 751 Test Methods, Practices, and Terminology for Chemical Analysis of Steel Products²
- D 3951 Practice for Commercial Packaging³
- E 3 Practice for Preparation of Metallographic Specimens⁴
- E 18 Test Methods for Rockwell Hardness and Rockwell Superficial Hardness of Metallic Materials⁴
- E 112 Test Methods for Determining Average Grain Size⁴
- E 384 Test Method for Microindentation Hardness of Materials⁴
- F 606 Test Methods for Determining the Mechanical Properties of Externally and Internally Threaded Fasteners, Washers, and Rivets⁵

F 788/F 788M Specification for Surface Discontinuities of Bolts, Screws, and Studs, Inch and Metric Series⁵

2.2 ANSI/ASME Standards:

- B18.3 Socket Cap, Shoulder and Set Screws—Inch Series⁶
- B18.24.1 Part Identifying Number (PIN) Code System⁷

3. Ordering Information

3.1 Orders for material under this specification shall include the following:

- 3.1.1 Quantity (number of screws).
 - 3.1.2 Dimensions, including nominal thread designation, thread pitch, and nominal screw length (inches). A standard part number may be used for this definition.
 - 3.1.3 Name of the screw: SBHCS or SFHCS.
 - 3.1.4 Coating, if required. If a protective finish other than black oxide is required, it must be specified on the order or product standard.
 - 3.1.5 Lot testing, if required (see 10.3).
 - 3.1.6 Certification, if required (see 14.1).
 - 3.1.7 ASTM designation and year of issue.
 - 3.1.8 Any special requirements.
 - 3.1.9 For establishment of a part identifying system, see ASME B18.24.1.
- 3.2 *Example*—1000 pieces 0.250 – 20 × 0.375 SBHCS lot tensile test. ASTM F 835–XX.

4. Materials and Manufacture

- 4.1 The screws shall be fabricated from alloy steel made to fine grain practice. In the event of controversy over grain size, referee tests on finished screws conducted in accordance with Test Methods E 112 shall prevail.
- 4.2 Screws shall be hot or cold upset or extruded, or both.

¹ This specification is under the jurisdiction of ASTM Committee F16 on Fasteners and is the direct responsibility of Subcommittee F16.02 on Steel Bolts, Nuts, Rivets, and Washers.

Current edition approved May 10, 2003. Published June 2003. Originally approved in 1986. Last previous edition approved in 2000 as F 835 – 00.

² *Annual Book of ASTM Standards*, Vol 01.03.

³ *Annual Book of ASTM Standards*, Vol 15.09.

⁴ *Annual Book of ASTM Standards*, Vol 03.01.

⁵ *Annual Book of ASTM Standards*, Vol 01.08.

⁶ Available from American National Standards Institute (ANSI), 25 W. 43rd St., 4th Floor, New York, NY 10036.

⁷ Available from American Society of Mechanical Engineers (ASME), ASME International Headquarters, Three Park Ave., New York, NY 10016-5990.

*A Summary of Changes section appears at the end of this standard.

4.3 Unless otherwise specified, threads shall be rolled for diameters through 0.625 in. and for screw lengths through 4 in. For diameters and lengths other than this, threads may be rolled, cut or ground.

4.4 Screws shall be heat treated by quenching in oil from above the transformation temperature and then tempering by reheating to at least 650°F to be within the hardness range specified in Table 1.

4.4.1 The minimum tempering temperature may be verified by submitting screws to 635°F for 30 min at temperature. The average cross-section hardness of three readings on the screw before and after retempering shall not differ by more than 20 DPH.

4.5 When protective or decorative coatings are applied to the screws, precautions as required by the coatings shall be taken to prevent embrittlement.

5. Chemical Composition

5.1 The chemical composition of the screw material shall conform to the heat analysis specified in Table 2.

5.2 One or more of the following alloying elements, chromium, nickel, molybdenum, or vanadium, shall be present in the steel in sufficient quantity to ensure the specific strength properties are met after oil quenching and tempering. The steel shall meet the AISI definition of alloy steel, that is, maximum and minimum element content requirement or minimum element limits specified.

5.3 Steel to which bismuth, selenium, tellurium, or lead has been added intentionally shall not be permitted.

5.4 Material analysis may be made by the purchaser from finished products and the chemical composition thus determined shall conform to the requirements specified for the product analysis in Table 2.

6. Mechanical Properties

6.1 The finished screws shall conform to the mechanical requirements specified in Table 1.

6.2 Screws having a nominal length equal to or greater than 3 diameters shall be tested full size and shall conform to the full-size tensile requirements specified in Table 3. Tensile failures through the head are acceptable provided the load requirements are satisfied.

6.3 Screws having a nominal thread diameter-length combination as specified in 6.2 and a breaking load exceeding

TABLE 1 Mechanical Requirements

	Nominal Thread Size, in.	
	0.500 and smaller	Over 0.500
<i>Full-size Screws:</i>		
Tensile, min, ksi	145	135
<i>Machined Test Specimen:</i>		
Yield strength at 0.2 % offset, min, ksi	^A	153
Tensile strength, min, ksi	^A	170
Elongation in 4D, min, %	^A	8
Reduction of area, min, %	^A	35
<i>Product Hardness:</i>		
Rockwell C	39–44	37–44
Vickers DPH	382–434	363–434

^A Not applicable.

TABLE 2 Chemical Requirements

Element	Composition, %	
	Heat Analysis	Product Analysis
Carbon	0.30 to 0.48	0.28 to 0.50
Phosphorus, max	0.035	0.040
Sulfur, max	0.040	0.045
Alloying elements	see 5.2	see 5.2

TABLE 3 Minimum Ultimate Tensile Loads

Thread Size		Stress Area, in. ²		Button and Countersunk Heads, Tensile Load, min lb ^A
Coarse	Fine	Coarse	Fine	
...	0.060-80	...	0.00180	260
0.073-64	0.073-72	0.00263	0.00278	380
0.086-56	0.086-64	0.00370	0.00394	540
0.099-48	0.099-56	0.00487	0.00523	710
0.112-40	0.112-48	0.00604	0.00661	880
0.125-40	0.125-44	0.00796	0.00830	1150
0.138-32	0.138-40	0.00909	0.01015	1320
0.164-32	0.164-36	0.0140	0.010474	2030
0.190-24	0.190-32	0.0175	0.0200	2540
0.250-20	0.250-28	0.0318	0.0384	4610
0.3125-18	0.3125-24	0.0524	0.0580	7600
0.375-16	0.375-24	0.0775	0.0878	11 200
0.4375-14	0.4375-20	0.1063	0.1187	15 400
0.500-13	0.500-20	0.1419	0.1599	20 600
0.625-11	0.625-18	0.226	0.258	30 500
0.750-10	0.750-16	0.334	0.373	45 100
0.875-9	0.875-14	0.462	0.509	62 400
1.000-8	1.000-12	0.606	0.663	81 800
1.125-7	1.125-12	0.763	0.858	103 000
1.250-7	1.250-12	0.969	1.073	131 000
1.375-6	1.375-12	1.155	1.315	156 000
1.500-6	1.500-12	1.405	1.581	190 000

^A Because of the head critical configuration of these parts, the full size tensile loads are based on 80 % of the minimum heat treated material strength (180 ksi for sizes 0.500 in. and smaller and 170 ksi for sizes larger than 0.500 in.) and the stress areas for coarse thread screws.

200 000 lb preferably shall be tested full size and shall meet the full-size tensile properties in Table 3. When equipment of sufficient capacity for such tests is not available or if excessive length of the screws makes full-size testing impractical, standard round machined specimens may be used that shall meet the machined test specimen tensile properties in Table 1. If discrepancy between full-size and machined specimen results, full-size tests shall be used as the referee method to determine acceptance.

6.4 Screws that are too short (lengths less than 3 times nominal size) or that have insufficient threads for tension testing shall not be subject to tension tests but shall conform to the hardness (minimum and maximum) requirements of Table 1.

6.5 All screws, regardless of size, shall conform to the hardness specified in Table 1. Hardness shall be met anywhere on the cross section through the threaded portion one diameter from the screw point.

7. Other Requirements

7.1 Decarburization:

7.1.1 There shall be no evidence of carburization or gross decarburization on the surfaces of the heat-treated screws when measured in accordance with 11.5.

7.1.2 The depth of partial decarburization shall be limited to the values in Table 4 when measured as shown in Fig. 1, and in accordance with 11.5.

7.2 *Embrittlement*—Coated screws shall withstand the embrittlement test in accordance with 11.4 without showing indications of discontinuities. The loading shall be calculated with minimum screw tensile requirements.

8. Dimensions

8.1 Unless otherwise specified, the dimensions shall conform to the requirements of ANSI/ASME B 18.3.

9. Workmanship, Finish, and Appearance

9.1 *Surface Finish*—The screws shall have a black (thermal or chemical) oxide finish, unless otherwise specified.

9.2 Surface Discontinuities:

9.2.1 The surface discontinuities for these products shall conform to Specification F 788/F 788M and the additional limitations specified herein.

9.2.2 Forging defects that connect the socket to the periphery of the head are not permissible. Defects originating on the periphery and with a traverse indicating a potential to intersect are not permissible. Other forging defects are permissible, provided those located in the bearing area, fillet and top surfaces shall not have a depth exceeding 0.03 D or 0.005 in., whichever is greater. For peripheral discontinuities, the maximum depth may be 0.06 D not to exceed 0.040 in. (see Fig. 2).

9.2.3 Forging defects located in the socket wall within 0.1 times the actual key engagement, T , from the bottom of the socket are not permissible. Discontinuities located elsewhere in the socket shall not have a length exceeding 0.25 T or a maximum depth of 0.03 D not to exceed 0.005 in. (see Fig. 3).

9.2.4 Seams in the shank shall not exceed a depth of 0.03 D or 0.008 in., whichever is greater.

9.2.5 No transverse discontinuities shall be permitted in the head-to-shank fillet area.

9.2.6 Threads shall have no laps at the root or on the flanks, as shown in Fig. 4. Laps are permitted at the crest (Fig. 4c) that do not exceed 25 % of the basic thread depth and on the flanks outside the pitch cylinder. Longitudinal seams rolled beneath the root of the thread and across the crests of cut threads are acceptable within the limits of 9.2.4.

9.2.7 Quench cracks of any depth, any length, or in any location are not permitted.

10. Number of Tests

10.1 The requirements of this specification shall be met in continuous mass production for stock, and the manufacturer shall make sample inspections to ensure that the product conforms to the specified requirements. Additional tests of individual shipments of material are not ordinarily contemplated. A record of individual heats of steel in each test lot shall be maintained. The container shall be coded to permit identification of the lot.

10.2 When specified in the order, the manufacturer shall furnish a test report certified to be the last complete set of mechanical tests for each stock size in each shipment.

10.3 When additional tests are specified on the purchase order, a lot, for purposes of selecting test samples, shall consist of all screws offered for inspection at one time of one diameter and length. From each lot, the number of samples for each requirement shall be as follows:

Number of Pieces in Lot	Number of Samples
800 and less	1
Over 800 to 8000, incl	2
Over 8000 to 22 000, incl	3
Over 22 000	5

10.4 Should any sample fail to meet the requirements of a specified test, double the number of samples from the same lot shall be retested for the requirement(s) in which it failed. All of the additional samples shall conform to the specification or the lot shall be rejected.

11. Test Methods

11.1 Chemical analysis shall be conducted in accordance with Test Methods, Practices, and Terminology A 751.

11.2 Tensile properties shall be determined in accordance with Test Methods F 606.

11.3 Hardness shall be determined in accordance with Test Methods E 18.

11.4 Embrittlement tests shall be conducted in accordance with Test Methods F 606. The countersunk washer for the flat countersunk head cap screw shall be placed with the axis of the conical recess at the required wedge angle with the fastener axial load.

11.5 Decarburization and carburization tests shall be conducted as follows:

11.5.1 Section the thread area of the bolt longitudinally through the axis, mount, and polish it in accordance with Guide E 3. Take measurements (1) at the minor diameter in the center of the thread ridge and (2) 0.75 h toward the thread crest on the

TABLE 4 Decarburization Limits

Threads/in.	Thread Height, h_s	0.75 h_s from Root to Crest, min	0.1 h_s at Root, max
48	0.013	0.010	0.001
44	0.014	0.011	0.001
40	0.015	0.011	0.002
36	0.017	0.013	0.002
32	0.019	0.014	0.002
28	0.022	0.017	0.002
24	0.026	0.020	0.003
20	0.031	0.023	0.003
18	0.034	0.026	0.003
16	0.038	0.029	0.004
14	0.044	0.033	0.004
13	0.047	0.035	0.005
12	0.051	0.038	0.005
11	0.056	0.042	0.006
10	0.061	0.046	0.006
9	0.068	0.051	0.007
8	0.077	0.058	0.008
7	0.088	0.066	0.009
6	0.102	0.077	0.010

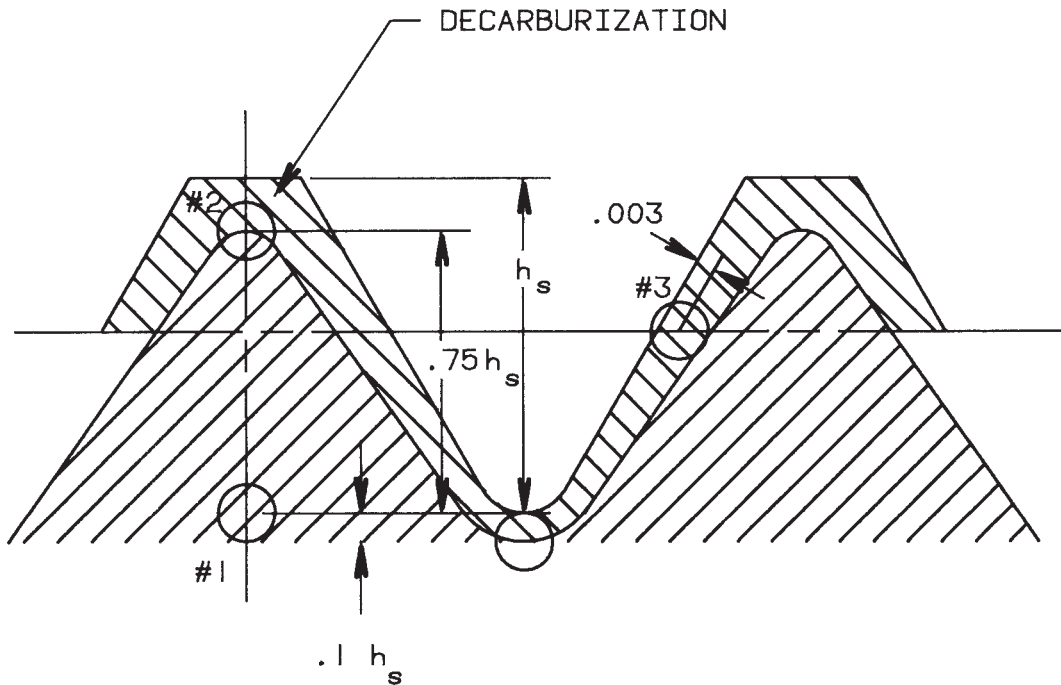

FIG. 1 Decarburization Limits

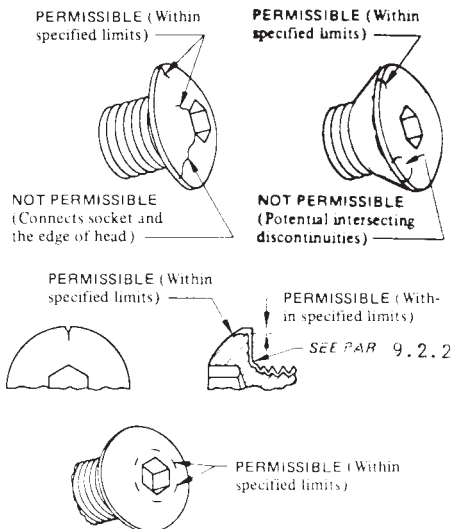

FIG. 2 Head and Body Discontinuity Limitations

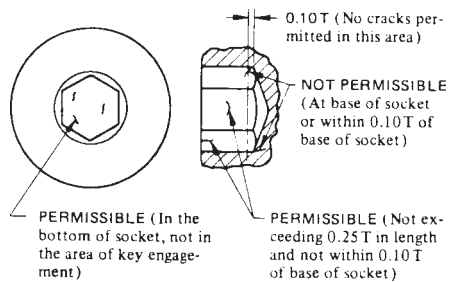

FIG. 3 Socket Discontinuity Limitations

decarburization evaluation either optical or microhardness measurements. The microhardness measurement shall constitute a referee method in case of dispute.

11.5.2 For optical measurement, etch the section in 2 – 4 % nital. Examine the surface of the etched samples under a microscope at 100 × using a measuring eyepiece graduated in 0.001-in. increments. The width of any light etching band normally defines the decarburization depth. A dark etching band indicates the possibility of carburization.

11.5.3 Measure microhardness in accordance with Test Method E 384 on unetched specimens using a DPH 136° indenter or a Knoop indenter using the following load application:

Number of Threads per Inch	Load
Less than 40	500 gf
40, 44, and 48	200 gf
Over 48	Use optical evaluation in 11.5.2.

11.5.3.1 Take measurements at the minor diameter (Reading Number 1) on the thread crest bisector to determine base metal hardness. Take measurements (Reading Number 2) on the bisector 0.75 h from the minor measurement toward the crest. Also take measurements (Reading Number 3) on the thread flank at the pitch line at a depth within 0.003 from the surface. Reading Number 3 may be taken on the same or an adjacent thread.

11.5.4 Interpret microhardness readings as follows:

11.5.4.1 A decrease of more than 30 hardness points from Reading Number 1 to Reading Number 2 shall be regarded as decarburization and indicates the screw does not conform to specification requirements.

11.5.4.2 An increase of more than 30 hardness points from Reading Number 1 to Reading Number 3 shall be regarded as

perpendicular bisector of the thread ridge. Take a measurement (3) on the thread flank approximately at the pitch line at a depth of 0.003 in. Use one of the two methods for carburization/

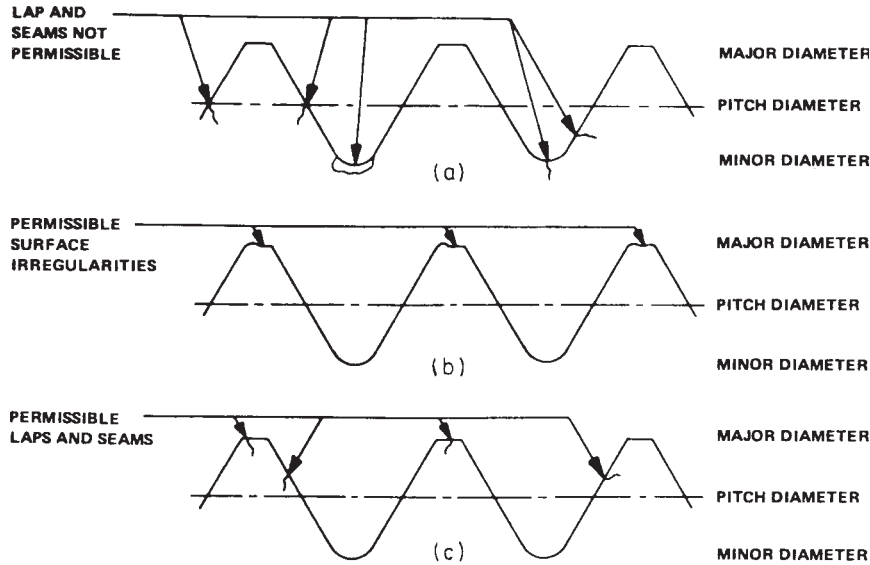

FIG. 4 Thread Discontinuities

carburization and indicates that the screw does not conform to specification requirements.

12. Inspection

12.1 The inspector representing the purchaser, upon reasonable notice, shall have free entry to all parts of the manufacturer's works that concern the manufacture of the material ordered. The manufacturer shall afford the inspector all reasonable facilities to satisfy him that the material is being furnished in accordance with this specification. All tests and inspections required by the specification that are requested by the purchaser's representative shall be made before shipment and shall be so conducted as not to interfere unnecessarily with the operation of the works.

13. Rejection and Rehearing

13.1 Material that fails to conform to the requirements of this specification may be rejected. Rejection should be reported to the producer or supplier promptly and in writing. In case of dissatisfaction with the results of the test, the producer or supplier may make claim for a rehearing.

14. Certification

14.1 Upon request of the purchaser in the contract or order, a manufacturer's certification that the material was manufactured and tested in accordance with this specification together with a report of the latest mechanical tests of each stock size in each shipment shall be furnished at the time of shipment.

15. Responsibility

15.1 The party responsible for the fastener shall be the organization that supplies the fastener to the purchaser and certifies that the fastener was manufactured, sampled, tested and inspected in accordance with this specification and meets all of its requirements.

16. Packaging and Package Marking

16.1 *Packaging:*

16.1.1 Unless otherwise specified, the packaging shall be in accordance with Practice D 3951.

16.1.2 When special packaging requirements are required, they shall be defined at the time of the inquiry and order.

16.2 *Package Marking:*

16.2.1 Each shipping unit shall include or be plainly marked with the following information:

- 16.2.1.1 ASTM designation,
- 16.2.1.2 Brand name or trademark of the manufacturer,
- 16.2.1.3 Number of pieces,
- 16.2.1.4 Purchase order number, and
- 16.2.1.5 Country of origin.

17. Keywords

17.1 alloy steel; cap screws; socket button head; socket flat countersunk head; steel

SUMMARY OF CHANGES

This section identifies the location of selected changes to this standard that have been incorporated since the F 835 - 00 issue. For the convenience of the user, Committee F16 has highlighted those changes that impact the use of this standard. This section may also include descriptions of the changes or reasons for the changes, or both.

(1) Deleted the 24 hour test time and deferred to the Test Methods F 606 48 hour test time in 7.2

ASTM International takes no position respecting the validity of any patent rights asserted in connection with any item mentioned in this standard. Users of this standard are expressly advised that determination of the validity of any such patent rights, and the risk of infringement of such rights, are entirely their own responsibility.

This standard is subject to revision at any time by the responsible technical committee and must be reviewed every five years and if not revised, either reapproved or withdrawn. Your comments are invited either for revision of this standard or for additional standards and should be addressed to ASTM International Headquarters. Your comments will receive careful consideration at a meeting of the responsible technical committee, which you may attend. If you feel that your comments have not received a fair hearing you should make your views known to the ASTM Committee on Standards, at the address shown below.

This standard is copyrighted by ASTM International, 100 Barr Harbor Drive, PO Box C700, West Conshohocken, PA 19428-2959, United States. Individual reprints (single or multiple copies) of this standard may be obtained by contacting ASTM at the above address or at 610-832-9585 (phone), 610-832-9555 (fax), or service@astm.org (e-mail); or through the ASTM website (www.astm.org).