



Standard Specification for Stainless Steel Socket Head Cap Screws¹

This standard is issued under the fixed designation F 837; the number immediately following the designation indicates the year of original adoption or, in the case of revision, the year of last revision. A number in parentheses indicates the year of last reapproval. A superscript epsilon (ϵ) indicates an editorial change since the last revision or reapproval.

This standard has been approved for use by agencies of the Department of Defense.

1. Scope

1.1 This specification covers the chemical and mechanical requirements for stainless steel inch socket head cap screw (SHCS) with nominal thread 0.060 through 1.500 in. and intended for use in applications requiring general corrosion resistance.

1.2 Two groups of stainless steel alloys are covered, austenitic Group 1 and martensitic Group 5.

1.3 Four property conditions are covered: austenitic Alloy Group 1 in an annealed condition (AF) at 85 ksi maximum, in two cold worked conditions (CW) at 80 ksi minimum, (CW1) at 102 ksi minimum, and martensitic Alloy Group 5 in a heat treated condition (HT) at 160 ksi minimum.

1.4 The following precautionary caveat pertains only to the test method portion, Section 13, of this specification: *This standard does not purport to address all of the safety concerns, if any, associated with its use. It is the responsibility of the user of this standard to establish appropriate safety and health practices and determine the applicability of regulatory limitations prior to use.*

2. Referenced Documents

2.1 ASTM Standards:

A 262 Practices for Detecting Susceptibility to Intergranular Attack in Austenitic Stainless Steels²

A 342 Test Methods for Permeability of Feebly Magnetic Materials³

A 380 Practice for Cleaning, Descaling, and Passivation of Stainless Steel Parts, Equipment, and Systems²

A 555/A 555M Specification for General Requirements for Stainless Steel Wire and Wire Rods²

A 751 Test Methods, Practices, and Terminology for Chemical Analysis of Steel Products²

A 967 Specification for Chemical Passivation Treatments for Stainless Steel Parts²

¹ This specification is under the jurisdiction of ASTM Committee F16 on Fasteners and is the direct responsibility of Subcommittee F16.04 on Nonferrous Fasteners.

Current edition approved July 10, 2002. Published September 2002. Originally published as F 837 – 88. Last previous edition F 837 – 02.

² Annual Book of ASTM Standards, Vol 01.03.

³ Annual Book of ASTM Standards, Vol 03.04.

D 3951 Practice for Commercial Packaging⁴

E 18 Test Methods for Rockwell Hardness and Rockwell Superficial Hardness of Metallic Materials⁵

E 92 Test Method for Vickers Hardness of Metallic Materials⁵

E 384 Test Method for Microhardness of Materials⁵

F 593 Specification for Stainless Steel Bolts, Hex Cap Screws, and Studs⁶

F 606 Test Methods for Determining the Mechanical Properties of Externally and Internally Threaded Fasteners, Washers, and Rivets⁶

F 788/F 788M Specification for Surface Discontinuities on Bolts, Screws, and Studs, Inch and Metric Series⁶

F 1470 Guide for Fastener Sampling for Specified Mechanical Properties and Performance Inspection⁶

2.2 ASME Standard:

ASME B18.3 Socket Cap, Shoulder, and Set Screws—Inch Series⁷

3. Classification

3.1 The designation of the alloy group and condition for the two materials and conditions of this specification shall be consistent with the stainless steel designations in Specification F 593.

3.2 The austenitic stainless steel socket head cap screw shall be designated F 837 Group 1 Condition AF, F 837 Group 1 Condition CW, or F837 Group 1 Condition CW1.

3.3 The martensitic stainless steel socket head cap screw shall be designated F 837 Group 5 Condition HT.

4. Ordering Information

4.1 Orders for socket head cap screws under this specification shall include:

4.1.1 Quantity (number of pieces of each item).

4.1.2 Name of the item (socket head cap screws, SHCS).

4.1.3 Size (nominal diameter, thread pitch, thread class, screw length) or part number.

4.1.4 Alloy Group and Condition (Group 1 AF, Group 1

⁴ Annual Book of ASTM Standards, Vol 15.09.

⁵ Annual Book of ASTM Standards, Vol 03.01.

⁶ Annual Book of ASTM Standards, Vol 01.08.

⁷ Available from Global Engineering Documents, 15 Inverness Way East, Englewood, CO 80112.

CW, Group 1 CW1, or Group 5 HT).

4.1.5 ASTM specification and year of issue. When year of issue is not specified, fasteners shall be furnished to the latest issue.

4.1.6 Supplementary requirements, if any, (see S1 through S7).

4.1.7 Additional special requirements, if any, to be specified on the purchase order:

4.1.7.1 Forming (see 5.1).

4.1.7.2 Threading (see 5.2).

4.1.7.3 Surface finish (see 11.1).

4.1.7.4 Alloy selection (see 7.2).

4.1.7.5 Test report (see 12.2).

4.1.7.6 Additional testing (see 12.3).

4.1.7.7 Inspection (see 14.1).

4.1.7.8 Rejection (see 15.1).

4.1.7.9 Certification (see 16.1).

4.1.7.10 Special packaging requirements (see 17.2).

4.1.7.11 Supplementary requirements as needed.

5. Materials and Manufacture

5.1 *Heads*—Unless otherwise specified the head and socket recess of the screw may be hot forged, cold forged, or machined at the option of the manufacturer. Users requiring cold forged heads should specify Supplementary Requirements S1.

5.2 *Threads*—Unless otherwise specified, screws in sizes up to 1.00 in. inclusive and product lengths up to 6 in. inclusive, shall have threads formed by rolling, except by special agreement with the purchaser. Larger products may be rolled, cut, or ground at the option of the manufacturer.

6. Heat Treatment

6.1 Austenitic alloys Group 1 Condition AF screws, following manufacture, shall be annealed by heating to $1900 \pm 50^\circ\text{F}$ to obtain maximum corrosion resistance and minimum permeability. The screws shall be held for a sufficient time at temperature and then cooled at a rate sufficient to prevent precipitation of the carbide and to provide the properties specified in Table 1.

6.2 When Condition CW or CW1 is specified, the austenitic alloys shall be annealed as specified in 6.1 generally by the raw material manufacturer, then cold worked to develop specific properties.

6.3 Martensitic alloy Group 5 Condition HT screws shall be hardened and tempered by heating to $1800 \pm 50^\circ\text{F}$ sufficient for austenitization, holding for at least $\frac{1}{2}$ h, rapid air or oil quenching, reheating to 525°F minimum and holding for at least 1 h and then air cooling to provide the properties specified in Table 1.

7. Chemical Properties

7.1 It is the intent of this specification that screws shall be ordered by alloy group and condition. The chemical composition of the screw material shall conform to the requirements of Table 2.

7.2 Unless otherwise specified in the inquiry and purchase order (see Supplementary Requirements S2) when Alloy Group 1 is specified, the choice of alloy used by the manufacturer shall be clearly identified on all certification required in the purchase order and shall have chemical composition conforming to the limits specified in Table 2.

7.3 When chemical analysis is performed by the purchaser using finished fasteners representing each lot, the chemical contents obtained shall conform to the limits specified in Table 2 for the specific alloy. Chemical contents shall conform to the tolerances specified in Specification A 555/A 555M.

7.3.1 In the event of discrepancy, a referee analysis as specified in 13.1 of samples for each lot shall be made in accordance with 12.3.1.

8. Mechanical Properties

8.1 Screws shall be tested in accordance with the mechanical testing requirements for the alloy group and condition nominal thread diameter, length, and specified minimum tensile strength as specified in Table 3 and shall meet the mechanical requirements specified for that product in Table 1.

8.2 For products on which both hardness and tension tests are performed, acceptance based on tensile requirements shall take precedence over low hardness readings (see Table 4).

9. Corrosion Resistance

9.1 Carbide Precipitation:

9.1.1 Rod, bar, and wire in the austenitic alloy group 1 (not including the free-machining grade 303) used to make fasteners in accordance with this specification shall be capable of passing the test for susceptibility to intergranular corrosion as specified in Practice E of Practice A 262.

TABLE 1 Mechanical Property Requirements

Alloy Group	Condition	Nominal Thread Diameter ^A	Full-Size Product		Machine Specimen			Core Hardness ^B	
			Tensile Strength, ksi	Minimum Extension ^C	Tensile Strength, ksi	Yield Strength, ksi	Minimum Elongation, %	Vickers	Rockwell
1	AF	0.060–1.500	85 max	0.6D	85 max	55 max	40	210 max	95 HRB max
1	CW	0.060–0.750	80 min	0.4D	80 min	40 min	25	150 min	50 HRA min
1	CW1	0.060–0.750	102 min	0.4D	87 min	65 min	20	220 min	59 HRA min
5	HT	0.060–0.190	180 min	350–423	36–43 HRC
5	HT	0.250–1.500	180 min	0.2D	160 min	120 min	12	350–423	36–43 HRC

^A For CW and CW1 condition fasteners with normal thread diameter larger than 0.750 in., the mechanical properties shall be agreed upon between the user and manufacturer.

^B Core hardness is only required when full-size product tensile testing cannot be accomplished.

^C D denotes normal thread size.

TABLE 2 Chemical Requirements

Alloy Group	UNS Designation	Alloy	Composition, % maximum except as shown								
			Carbon	Manganese	Phosphorus	Sulfur	Silicon	Chromium	Nickel	Copper	Molybdenum
Austenitic Alloys											
1	S30300	303 ^A	0.15	2.00	0.20	0.15 min	1.00	17.0 to 19.0	8.0 to 10.0	...	0.60 max ^B
1	S30400	304	0.08	2.00	0.045	0.030	1.00	18.0 to 20.0	8.0 to 10.5	1.00	...
1	S30403	304L	0.030	2.00	0.045	0.030	1.00	18.0 to 20.0	8.0 to 12.0	1.00	...
1	S30500	305	0.12	2.00	0.045	0.030	1.00	17.0 to 19.0	10.5 to 13.0	1.00	...
1	S38400	384	0.08	2.00	0.045	0.030	1.00	15.0 to 17.0	17.0 to 19.0
1	S20300	XM1 ^A	0.08	5.0 to 6.5	0.040	0.18 to 0.35	1.00	16.0 to 18.0	5.0 to 6.5	1.75 to 2.25	0.50 max ^B
1	S30430	18-9LW	0.10	2.00	0.045	0.030	1.00	17.0 to 19.0	8.0 to 10.0	3.00 to 4.00	...
1	S30433	302HQ	0.03	2.00	0.045	0.030	4.00	17.0 to 19.0	8.0 to 10.0	3.0 to 4.0	...
1	S31600	316	0.08	2.00	0.045	0.030	1.00	16.0 to 18.0	10.0 to 14.0	...	2.0 to 3.0
1	S31603	316L	0.03	2.00	0.045	0.030	1.00	16.0 to 18.0	10.0 to 14.0	...	2.0 to 3.0
Martensitic Alloys											
5	UNS41000	410	0.15	1.00	0.040	0.030	1.00	11.5 to 13.5		...	

^A Free machining grades are not recommended for forged product. These grades may be furnished only when approved by the purchaser.

^B At manufacturer's option, determined only when intentionally added.

TABLE 3 Mechanical Testing Requirements

Item	Product Length	Hardness		Test Conducted Using Full Size Product		Test Conducted Using Machined Test Specification		
		max	min	Extension	Axial Tensile Strength	Yield Strength 0.2 % offset	Tensile Strength	Elongation
1	≤3 <i>D</i> ^A	<i>B</i>	<i>B</i>	...	<i>B</i>
2	>3 <i>D</i> -12 in.	<i>B</i>	...	<i>B</i>	<i>B</i>
3	Over 12 in.	<i>B</i>	...	A	A	B	B	B

^A *D* denotes nominal diameter of product.

^B Denotes mandatory test. In addition, either all tests denoted by A or all tests denoted by B shall be performed. In case of arbitration full size tests, denoted A, shall be decisive.

9.1.2 As stated in Practices A 262, samples may be subjected to the faster and more severe screening test in accordance with Practice A. Failing Practice A, specimens shall be tested to Practice E and be considered satisfactory if passing Practice E.

10. Dimensions

10.1 Unless otherwise specified, the products shall conform to the requirements of ASME B18.3.

11. Workmanship, Finish, and Appearance

11.1 *Surface Treatment*—Unless otherwise specified, screws shall be cleaned, descaled and passivated in accordance with Practice A 380 or Specification A 967 at the option of the manufacturer.

11.2 The surface discontinuities for these products shall conform to Specification F 788/F 788M and the additional limitations specified herein.

11.2.1 Forging defects that connect the socket to the periphery of the head are not permissible. Defects originating on the periphery and with a traverse indicating a potential to intersect are not permissible. Other forging defects are permissible provided those located in the bearing area, fillet, and top surfaces shall not have a depth exceeding 0.03 *D* or 0.005 in, whichever is greater. For peripheral discontinuities, the maximum depth may be 0.06 *D* (see Fig. 1).

11.2.2 Forging defects located in the socket wall within 0.1 times the actual key engagement, *T*, from the bottom of the socket are not permissible. Discontinuities located elsewhere in

the socket shall not have a length exceeding 0.25 *T*, or a maximum depth of 0.03 *D* not to exceed 0.005 in. (see Fig. 2).

11.2.3 Seams in the shank shall not exceed a depth of 0.03 *D* or 0.008 in., whichever is greater.

11.2.4 No transverse discontinuities shall be permitted in the head-to-shank fillet area.

11.2.5 Threads shall have no laps at the root or on the flanks located below the pitch line. Laps are permitted at the crests (Fig. 3) that do not exceed 25 % of the basic thread depth, and on the flanks outside the pitch cylinder. Longitudinal seams rolled beneath the root of the thread and across the crests of cut threads are acceptable within the limits of 11.2.3.

12. Number of Tests

12.1 The requirements of this specification shall be met in continuous mass production for stock, and the manufacturer shall make sample inspections to ensure that the product conforms to the specified requirements. Additional tests of individual shipments of fasteners are not ordinarily necessary. A record of the individual heat of steel in each lot shall be maintained. The containers shall be coded to permit identification of the lot.

12.2 When specified in the purchase order, the manufacturer shall furnish a test report of the last complete set of chemical analysis and mechanical tests for each stock size in each shipment.

12.3 When tests of individual shipments are required, Supplementary Requirement S1 must be specified in the inquiry and order.

TABLE 4 Tensile Strength Values for Full-Size Fasteners, lbs

Nominal Size	Stress Area	Alloy Group 1			Alloy Group 5
		AF max	CW min	CW1 min	HT min
0.060-80	0.00180	153	144	183	288
0.073-64	0.00263	223	210	267	420
0.073-72	0.00278	236	222	283	444
0.086-56	0.00370	314	296	377	592
0.086-64	0.00394	334	315	401	630
0.099-48	0.00487	414	390	497	779
0.099-56	0.00523	445	418	533	837
0.112-40	0.00604	513	483	615	966
0.112-48	0.00661	562	529	674	1 060
0.125-40	0.00796	676	636	811	1 270
0.125-44	0.00830	706	665	848	1 330
0.138-32	0.00909	772	727	927	1 450
0.138-40	0.01015	862	811	1 035	1 620
0.164-32	0.0140	1 191	1 121	1 429	2 240
0.164-36	0.01474	1 252	1 178	1 502	2 360
0.190-24	0.0175	1 490	1 403	1 788	2 800
0.190-32	0.0200	1 699	1 600	2 039	3 200
0.250-20	0.0318	2 705	2 546	3 246	5 090
0.250-28	0.0364	3 092	2 910	3 710	5 820
0.312-18	0.0524	4 457	4 194	5 348	8 380
0.312-24	0.0580	4 936	4 645	5 923	9 280
0.375-16	0.0775	6 587	6 199	7 904	12 400
0.375-24	0.0878	7 465	7 026	8 958	14 000
0.437-14	0.1063	9 036	8 505	10 843	17 000
0.437-20	0.1187	10 091	9 497	12 109	19 000
0.500-13	0.1419	12 061	11 352	14 474	22 700
0.500-20	0.1599	13 596	12 796	16 315	25 600
0.625-11	0.226	19 210	18 080	23 052	36 200
0.625-18	0.256	21 756	20 477	26 108	41 000
0.750-10	0.334	28 429	26 757	34 115	53 400
0.750-16	0.373	31 702	29 837	38 042	59 700
0.875-9	0.462	39 247	73 900
0.875-14	0.509	43 305	81 400
1.000-8	0.606	51 488	97 000
1.000-12	0.663	56 359	106 000
1.125-7	0.763	64 878	122 000
1.125-12	0.856	72 736	137 000
1.250-7	0.969	82 374	155 000
1.250-12	1.073	91 200	172 000
1.375-6	1.155	98 165	185 000
1.375-12	1.315	111 751	210 000
1.500-6	1.405	119 446	225 000
1.500-12	1.581	134 387	253 000

12.3.1 When the purchaser does not specify the sampling plan and basis of acceptance, the following shall apply:

12.3.1.1 The lot, for purposes of selecting samples, shall consist of all products offered for inspection and testing, at one time, that are the same type, style, nominal diameter, thread pitch, nominal length, material (alloy), condition, and surface finish.

12.3.1.2 From each lot, samples shall be selected at random and tested for each requirement in accordance with the following plan:

Number of Pieces in Lot	Number of Samples
800 and less	1
Over 800 to 8000, incl	2
Over 8000 to 22 000, incl	3
Over 22 000	5

12.3.1.3 Should any sample fail to meet the requirements of a specified test, double the number of samples from the same lot shall be retested for the requirement(s) in which it failed.

All of the additional samples shall conform to the specification or the lot shall be rejected.

12.3.1.4 If the failure of a test specimen is due to improper preparation of the specimen or an incorrect testing technique, the specimen shall be discarded and another test specimen submitted.

12.4 Corrosion Resistance Tests:

12.4.1 Unless otherwise specified, inspection for corrosion resistance shall be in accordance with the manufacturer's standard quality control practices. No specific method of inspection is required, but the screws shall be produced from suitable raw material and manufactured by properly controlled practices to maintain resistance to corrosion. When corrosion tests are required, Supplementary Requirement S8 must be specified in the inquiry and order, except as noted in 12.4.2.

12.4.2 Products that have been hot worked shall be solution annealed and tested to determine freedom from precipitated carbides. Not less than one corrosion test shall be made from each lot. Corrosion test shall be performed in accordance with Practice A 262, Practices A or E as applicable.

13. Test Methods

13.1 *Chemical Analysis*—The chemical composition shall be determined in accordance with Test Method A 751.

13.1.1 The fastener manufacturer may accept the chemical analysis of each heat of raw material purchased and reported on the raw material certification furnished by the raw material producer. The fastener manufacturer is not required to do any further chemical analysis testing, provided that precise heat lot traceability has been maintained throughout the manufacturing process on each lot of fasteners produced and delivered.

13.2 Mechanical Tests:

13.2.1 Screws tested full size for axial strength, screw extension, and hardness shall be tested in accordance with the methods described in Test Methods F 606 and 13.2.3 of this specification. The hardness shall be determined using Test Methods E 18, E 92, or Test Method E 284, as appropriate.

13.2.2 Machined test specimens tested for tensile strength, yield strength at 0.2 % offset, and elongation shall be tested in accordance with the methods described in Test Methods F 606.

13.2.3 Extension Test is applicable only to full size products. The overall length of the test specimen (L_1) shall be measured within ± 0.005 in. The head and reference surface for length measurement may be the bottom of the hex socket for measuring purposes. The specimen shall be assembled into a threaded adapter to a depth of one nominal diameter and then axial tensile tested in accordance with 13.2.1 to failure. The two broken pieces shall be fitted closely together and the overall length (L_2) measured again. The total extension shall be computed by subtracting the original overall length from the length following fracture (Fig. 4). The product is acceptable when the extension equals or exceeds the minimum value for extension specified in Table 1.

13.3 *Corrosion Resistance*—When specified on the purchase order or inquiry, corrosion tests to determine freedom from precipitated carbides shall be performed in accordance with Practices A 262, Practice A or E as applicable.

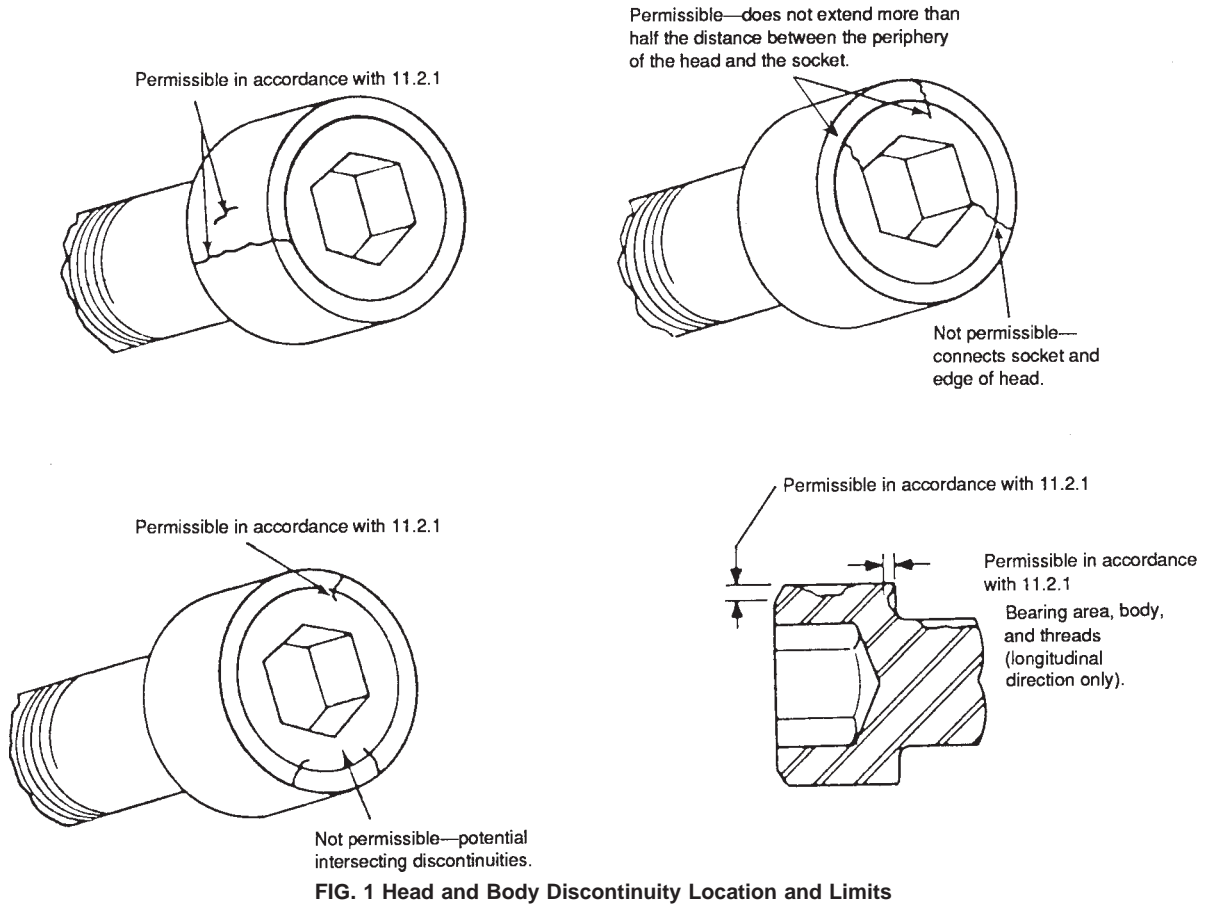

FIG. 1 Head and Body Discontinuity Location and Limits

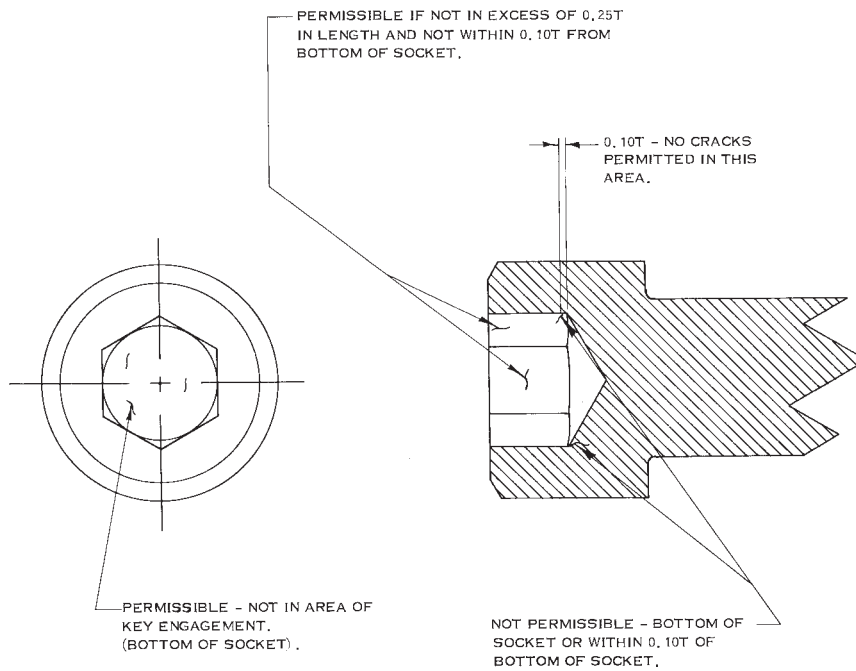

FIG. 2 Socket Discontinuity Location and Limits

14. Inspection

14.1 If the inspection described in 14.1 is required by the purchaser, it shall be specified in the inquiry, order, or contract.

14.2 The inspector representing the purchaser shall have free entry to all parts of the manufacturer's works that concern the manufacture of the material ordered. The manufacturer

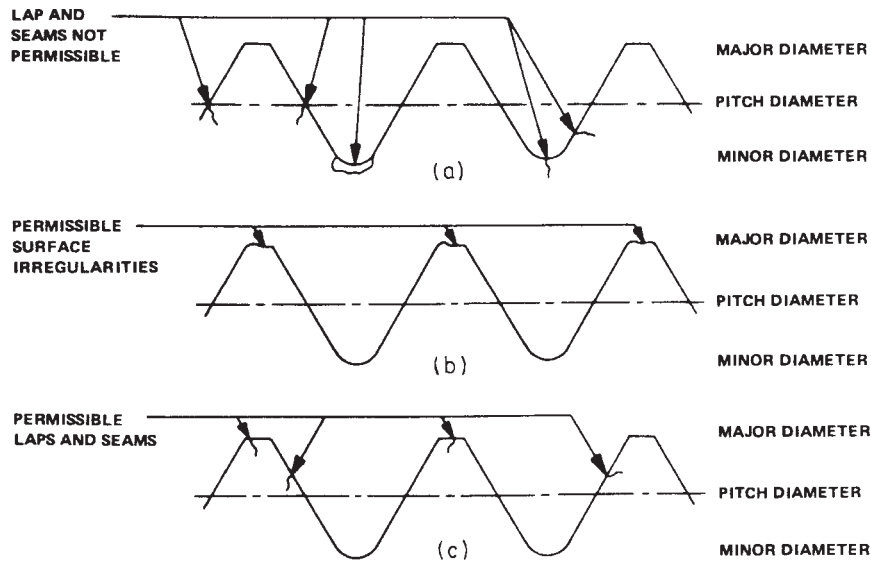

FIG. 3 Thread Discontinuities

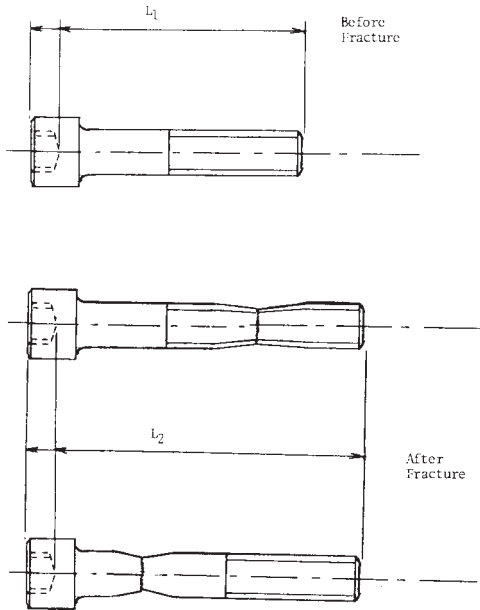

FIG. 4 Comparison of Overall Length Before and After Fracture

shall afford the inspector all reasonable facilities to satisfy that the material is being furnished in accordance with this specification. All tests and inspection required by the specification that are requested by the purchaser's representative and purchase order shall be made prior to shipment, and shall be so conducted as not to interfere unnecessarily with the operation of the work.

15. Rejection and Rehearing

15.1 Screws that fail to conform to the requirements of this specification may be rejected by the purchaser. Rejection shall be reported to the supplier promptly and in writing. In case of dissatisfaction with the results of tests or inspection authorized by the purchaser, the supplier may claim for a rehearing.

16. Certification

16.1 *Test Report*—The manufacturer shall maintain on file for a period of 5 years, the original test report, including a copy of the certified chemical analysis of the heat of material used and the results of the required testing for the lot of fasteners.

16.2 *Manufacturer's Certificate of Conformance*—The manufacturer shall maintain on file for a period of 5 years, a certificate indicating that the lot of fasteners was manufactured and tested in accordance with this specification and conforms to all specified requirements.

16.3 When requested by the purchaser, submission of copies of the test report, manufacturer's certificate, or an extension of the 5-year document retention period shall be performed as agreed between the manufacturer and the purchaser at the time of the inquiry or order.

17. Packaging and Package Marking

17. Unless otherwise specified packaging shall be in accordance with Practice D 3951.

17.1 When special packaging requirements are required by the purchaser, they shall be defined at the time of inquiry and order.

17.2 *Package Marking*—Each shipping unit shall include or be plainly marked with the following:

- 17.2.1 ASTM specification,
- 17.2.2 Alloy group and condition,
- 17.2.3 Alloy number,
- 17.2.4 Size,
- 17.2.5 Name and brand or trademark of the manufacturer,
- 17.2.6 Country of origin,
- 17.2.7 Number of pieces, and
- 17.2.8 Purchase order number.

18. Keywords

18.1 corrosion resistant; stainless steel; socket head cap screws

SUPPLEMENTARY REQUIREMENTS

The following supplementary requirements shall apply only when specified by the purchaser in the contract or order. Details of these supplementary requirements shall be agreed upon in writing between the manufacturer and purchaser. Supplementary requirements shall in no way negate any requirement of the specification itself.

S1. Shipment Lot Testing

S1.1 When Supplementary Requirement S1 is specified on the order, the manufacturer shall make sample tests on the individual lots for shipment to ensure that the product conforms to the specified requirements.

S1.2 The manufacturer shall make an analysis of a randomly selected finished fastener from each lot of product to be shipped. Heat or lot control shall be maintained. The analysis of the starting material from which fasteners have been manufactured may be reported in place of the product analysis.

S1.3 The manufacturer shall perform mechanical property tests in accordance with this specification and Guide F 1470 on the individual lots for shipment.

S1.4 The manufacturer shall furnish a test report for each lot in the shipment showing the actual results of the chemical analysis and mechanical property tests performed in accordance with Supplementary Requirement S1.

S2. Alloy Control

S2.1 When Supplementary Requirement S2 is specified on the inquiry and order, the manufacturer shall supply that alloy specified by the customer on the order with no group substitutions permitted without the written permission of the purchaser.

S3. Permeability

S3.1 When Supplementary Requirement S3 is specified on the inquiry and order, the permeability of Group 1 condition AF screws shall not exceed 1.05 at 100 oersteds when determined by Test Method A 342. Screws in Group 1 condition CW or CW1 may not be capable of meeting permeability and strength requirements simultaneously. Consultation with the raw material manufacturer should be considered for critical permeability requirements.

S4. Material Identification

S4.1 When Supplementary Requirement S4 is specified on

the inquiry and order, the fasteners shall be marked with the specific alloy number to identify the material in accordance with the purchaser's instructions.

S5. Alloy Condition Identification

S5.1 When Supplementary Requirement S5 is specified on the inquiry and order for nominal sizes $\frac{1}{4}$ (0.250) in. and larger, the fasteners shall be marked with the alloy condition letters as shown below:

Alloy Condition	Marking
Group 1 AF	AF
Group 1 CW	CW
Group 1 CW1	CW1
Group 5 HT	HT

S6. Manufacturer Identification

S6.1 When Supplementary Requirement S6 is specified on the inquiry and order for nominal sizes $\frac{1}{4}$ (0.250) in. and larger, the fasteners shall be marked with the manufacturer's insignia. The manufacturer's identification insignia shall be of the design, placed on the side or top of the head and recognizable to the purchaser. The insignia shall be readable with no greater than 10 \times magnification.

S7. Forged Heads

S7.1 When Supplementary Requirement S7 is specified on the inquiry and order, screw heads shall be cold forged by upset, extrusion, or both. The hexagon socket may be forged or machined at the manufacturer's option. This requirement may be inappropriate for large sizes.

S8. Corrosion Resistance Tests

S8.1 When Supplementary Requirement S8 is specified on the inquiry and order, corrosion test(s) shall be performed as agreed between the manufacturer and the purchaser at the time of the inquiry or order.

S9. Passivation

S9.1 When Supplementary Requirement S9 is specified on the inquiry and order, the finished product shall be passivated in accordance with Specification A 380.

ASTM International takes no position respecting the validity of any patent rights asserted in connection with any item mentioned in this standard. Users of this standard are expressly advised that determination of the validity of any such patent rights, and the risk of infringement of such rights, are entirely their own responsibility.

This standard is subject to revision at any time by the responsible technical committee and must be reviewed every five years and if not revised, either reapproved or withdrawn. Your comments are invited either for revision of this standard or for additional standards and should be addressed to ASTM International Headquarters. Your comments will receive careful consideration at a meeting of the responsible technical committee, which you may attend. If you feel that your comments have not received a fair hearing you should make your views known to the ASTM Committee on Standards, at the address shown below.

This standard is copyrighted by ASTM International, 100 Barr Harbor Drive, PO Box C700, West Conshohocken, PA 19428-2959, United States. Individual reprints (single or multiple copies) of this standard may be obtained by contacting ASTM at the above address or at 610-832-9585 (phone), 610-832-9555 (fax), or service@astm.org (e-mail); or through the ASTM website (www.astm.org).