



**METRIC**  
Designation: F 837M – 042a

## Standard Specification for Stainless Steel Socket Head Cap Screws [Metric]<sup>1</sup>

This standard is issued under the fixed designation F 837M; the number immediately following the designation indicates the year of original adoption or, in the case of revision, the year of last revision. A number in parentheses indicates the year of last reapproval. A superscript epsilon (ε) indicates an editorial change since the last revision or reapproval.

*This standard has been approved for use by agencies of the Department of Defense.*

### 1. Scope

1.1 This specification covers the chemical and mechanical requirements for stainless steel metric socket head cap screws (SHCS) with nominal thread M1.6 through M36 and intended for use in applications requiring general corrosion resistance.

1.2 Two groups of stainless steel alloys are covered, austenitic Grade A1 and martensitic Grade C1.

~~1.3 Three~~

1.3 Four property classes are covered: austenitic A1-50 in an annealed condition at ~~500~~ 585 MPa maximum; austenitic A1-55 in a cold worked condition at 550 MPa minimum; austenitic A1-70 in a cold worked condition at 700 MPa minimum, and martensitic C1-110 in a heat treated condition at 1100 MPa minimum.

1.4 This hazard statement pertains only to Section 13, Test Methods: *This standard does not purport to address all of the safety concerns, if any, associated with its use. It is the responsibility of the user of this standard to establish appropriate safety and health practices and determine the applicability of regulatory limitations prior to use.*

### 2. Referenced Documents

2.1 *ASTM Standards:*

A 262 Practices for Detecting Susceptibility to Intergranular Attack in Austenitic Stainless Steels<sup>2</sup>

<sup>1</sup> This specification is under the jurisdiction of ASTM Committee F16 on Fasteners and is the direct responsibility of Subcommittee F16.04 on Nonferrous Fasteners. Current edition approved ~~Oct. July 10, 2004~~<sup>2</sup>. Published ~~November 2001~~<sup>2</sup> September 2002. Originally published as F 837M – 83. Last previous edition F 837M – 002.

A 342 Test Methods for Permeability of Feebly Magnetic Materials<sup>3</sup>

A 380 Practices for Cleaning, Descaling, and Descaling Passivation of Stainless Steel Parts, Equipment, and Systems<sup>2</sup>

A 555/A555M Specification for General Requirements for Stainless and Heat-Resisting Steel Wire and Wire Rods<sup>2</sup>

A 751 Test Methods, Practices, and Terminology for Chemical Analysis of Steel Products<sup>2</sup>

A 967 Specification for Chemical Passivation Treatments for Stainless Steel Parts<sup>2</sup>

D 3951 Practice for Commercial Packaging<sup>4</sup>

~~E 353 Test 18 Test Methods for Chemical Analysis of Stainless, Heat-Resisting, Maraging, Rockwell Hardness and Other Similar Chromium-Nickel-Iron Alloys~~ Rockwell Superficial Hardness of Metallic Materials<sup>5</sup>

E 92 Test Method for Vickers Hardness of Metallic Materials<sup>5</sup>

E 384 Test Method for Microhardness of Materials<sup>5</sup>

F 606M Test Methods for Determining the Mechanical Properties of Externally and Internally Threaded Fasteners, Washers, and Rivets [Metric]<sup>6</sup>

F 738M Specification for Stainless Steel Metric Bolts, Screws, and Studs<sup>6</sup>

F 788/F788M Specification for Surface Discontinuities of Bolts, Screws, and Studs, Inch and Metric Series<sup>6</sup>

F 1470 Guide for Fastener Sampling for Specified Mechanical Properties and Performance Inspection<sup>6</sup>

2.2 *ASME Standard:*

ASME B 18.3.1M Socket Head Cap Screws (Metric Series)<sup>7</sup>

### 3. Classification

3.1 The designation of the property class for the two materials and conditions of this specification shall be consistent with the stainless steel designations in Specification F 738M.

3.2 The austenitic stainless steel socket head cap screw shall be designated F837M A1-50, F837M A1-55, or F 837M A1-70.

3.3 The martensitic stainless steel socket head cap screw shall be designated F837M C1-110.

### 4. Ordering Information

4.1 Orders for socket head cap screws under this specification shall include:

4.1.1 Quantity (number of pieces of each item),

4.1.2 Name of the item (socket head cap screws, SHCS),

4.1.3 Size (nominal diameter, thread pitch, thread class, screw length) or part number,

4.1.4 Property class (A1-50, A1-55, A1-70, or C1-110),

4.1.5 ASTM specification and date of issue. When date of issue is not specified, fasteners shall be furnished to the latest issue,

4.1.6 Supplementary requirements, if any (see S1 through S3),

4.1.7 Additional special requirements, if any, to be specified on the purchase order:

4.1.7.1 Forming (see 5.1),

4.1.7.2 Threading (see 5.2),

4.1.7.3 Surface finish (see 11.1),

4.1.7.4 Alloy selection (see 7.2),

4.1.7.5 Test report (see 11.2),

4.1.7.6 Additional testing (see section 12.3),

4.1.7.7 Inspection (see 13.1),

4.1.7.8 Rejection (see 14.1), and

4.1.7.9 Certification (see 15.1).

4.1.7.10 Special packaging requirements (see section 18.1.2).

### 5. Material and Manufacture

5.1 *Forging*—Unless otherwise specified, screws in sizes M3 through M20 with lengths up to 10 times the nominal product diameter or 150 mm, whichever is shorter, shall be cold headed except that they may be hot headed or machined by agreement with the purchaser. Larger sizes and lengths may be cold or hot headed. Screws smaller and larger than the M3 through M36 range may be machined. Sockets may be forged or machined at the option of the manufacturer.

5.2 *Threads*—Unless otherwise specified, screws in sizes up to M24 inclusive and product lengths up to 150 mm inclusive shall have threads formed by rolling, except by special agreement with the purchaser. Larger products may be rolled, cut, or ground at the option of the manufacturer.

<sup>2</sup> *Annual Book of ASTM Standards*, Vol 01.03.

<sup>3</sup> *Annual Book of ASTM Standards*, Vol 03.04.

<sup>4</sup> *Annual Book of ASTM Standards*, Vol 15.09.

<sup>5</sup> *Annual Book of ASTM Standards*, Vol 03.051.

<sup>6</sup> *Annual Book of ASTM Standards*, Vol 01.08.

<sup>7</sup> Available from Global Engineering Documents, 15 Inverness Way, Englewood, CO 80112.

## 6. Heat Treatment

6.1 Austenitic alloys class A1-50 screws, following manufacture, shall be annealed by heating to  $1040 \pm 30^\circ\text{C}$  to obtain maximum corrosion resistance and minimum permeability. The screws shall be held for a sufficient time at temperature and then cooled at a rate sufficient to prevent precipitation of the carbide and to provide the properties specified in Table 1.

6.2 When Condition A1-55 or A1-70 is specified, the austenitic alloys shall be annealed as specified in 6.1 generally by the raw material manufacturer, then cold worked to develop specific properties.

6.3 Martensitic alloy Class C1 110 screws shall be hardened and tempered by heating to  $1010 \pm 30^\circ\text{C}$  sufficient for austenitization, holding for at least  $\frac{1}{2}$  h, rapid air or oil quenching, reheating to  $275^\circ\text{C}$  minimum and holding for at least 1 h and then air cooling to provide the properties specified in Table 1.

## 7. Chemical Composition

7.1 It is the intent of this specification that screws shall be ordered by property class. The chemical composition of the screw material shall conform to the requirements of Table 2.

7.2 Unless otherwise specified in the inquiry and purchase order (see Supplementary Requirement S2) when A1-50, A1-55, or A1-70 property class is specified, the choice of alloy used by the manufacturer shall be clearly identified on all certification required in the purchase order ~~and shall have~~ The chemical composition conforming shall conform to the limits specified in Table 2.

7.3 When chemical analysis is performed by the purchaser using finished fasteners representing each lot, the chemical contents obtained shall conform to the limits specified in Table 2 for the specific alloy. Chemical contents shall conform to the tolerances specified in Specification A 555/A 555M.

7.3.1 In the event of discrepancy, a referee analysis as specified in 13.1 of samples for each lot shall be made in accordance with 12.3.1.1.

## 8. Mechanical Properties

8.1 Screws shall be tested in accordance with the mechanical testing requirements for the property class, nominal thread diameter, length, and specified minimum tensile strength as specified in Table 3 and shall meet the mechanical requirements specified for that product in Table 1.

8.2 For products on which both hardness and tension tests are performed, acceptance based on tensile requirements shall take precedence over low hardness readings (see Table 4).

## 9. Corrosion Resistance

### 9.1 Carbide Precipitation:

9.1.1 Rod, bar, and wire in the austenitic alloy group A1 (not including the free-machining grade 303) used to make fasteners in accordance with this specification shall be capable of passing the test for susceptibility to intergranular corrosion as specified in Practice E of Practices A 262.

9.1.2 As stated in Practices A 262, samples may be subjected to the faster and more severe screening test in accordance with Practice A. Failing Practice A, specimens shall be tested to Practice E and be considered satisfactory if passing Practice E.

**TABLE 1 Mechanical Property Requirements**

Property Class	Nominal Thread Diameter <sup>A</sup>	Full Size Product Tests		Machined Specimen Tests			Core Hardness <sup>B</sup>			
		Tensile Strength, MPa	Minimum Extension <sup>A,C</sup>	Tensile Strength, MPa	Yield Strength, MPa	Elongation, %	Vickers		Rockwell	
							min	max	min	max
A1-50	M1.6 to M5	500	...	...	...	...	155	220	B70	B95
A1-50	M1.6 to M36	500	...	...	...	...	155	220	B70	B95
A1-50	M6 to M36	500	0.6D	500	250	30	155	0 max		220
A1-50	M6 to M36	500	0.6D	585 max	380 max	40	2155	0 max		220
A1-70	M1.6 to M5	665	...	...	...	...	220	330	B96	G33
A1-70	M1.6 to M20	550 min	...	...	...	...	220	330	B96	G33
A1-70	M6 to M14	665	0.4D	650	400	25	16022 min		50330	B96
A1-70	M6 to M14	665	0.4D	550 min	270 min	25	160 min		50330	B96
A1-70	M16 to M36	550	0.2D	550	270	25	0	160 min		340
A1-70	M1.6 to M20	700 min	0.4D	600 min	450 min	25	0	220 min		340
C-110	M1.6 to M5	1100	...	...	...	...	350-440		440	G36C45
C-110	M1.6 to M5	1100	...	...	...	...	350-440		440	G36-45 HRC
	M6 to M36	1100	0.2D	1100	820	12	350-440		440	G36C45
	M6 to M36	1100	0.2D	1100	820	12	350-440		440	G36-45 HRC

<sup>A</sup> For A1-55 and A1-70 property class fasteners with nominal thread diameter larger than M20, the mechanical properties shall be agreed upon between the user and manufacturer.

<sup>B</sup> Core hardness is only required when full-size product tensile testing cannot be accomplished.

<sup>C</sup> D denotes nominal thread size.

**TABLE 2 Chemical Requirements**

Property Class	UNS Designation	Alloy	Composition, % maximum except as shown								
			Carbon	Manganese	Phosphorus	Sulfur	Silicon	Chromium	Nickel	Copper	Molybdenum
Austenitic Alloys											
—	S30300	303 <sup>A</sup>	0.15	2.00	0.20	0.15 min	1.00	17.0 to 19.0	8.0 to 10.0	—	0.60 max <sup>B</sup>
A1	S30300	303 <sup>A</sup>	0.15	2.00	0.20	0.15 min	1.00	17.0 to 19.0	8.0 to 10.0	...	0.60 max <sup>B</sup>
A1-50	S30400	304	0.08	2.00	0.045	0.030	1.00	18.0 to 20.0	8.0 to 10.5	1.00	—
A1	S30400	304	0.08	2.00	0.045	0.030	1.00	18.0 to 20.0	8.0 to 10.5	1.00	...
A1	S30403	304L	0.030	2.00	0.045	0.030	1.00	18.0 to 20.0	8.0 to 12.0	1.00	...
A1	S30403	304L	0.030	2.00	0.045	0.030	1.00	18.0 to 20.0	8.0 to 12.0	1.00	...
A1-70	S30500	305	0.12	2.00	0.045	0.030	1.00	17.0 to 19.0	10.5 to 13.0	1.00	—
A1	S30500	305	0.12	2.00	0.045	0.030	1.00	17.0 to 19.0	10.5 to 13.0	1.00	...
A1	S38400	384	0.08	2.00	0.045	0.030	1.00	15.0 to 17.0	17.0 to 19.0	...	...
A1	S38400	384	0.08	2.00	0.045	0.030	1.00	15.0 to 17.0	17.0 to 19.0	...	...
A1	S20300	XM1 <sup>A</sup>	0.08	5.0 to 6.5	0.040	0.18 to 0.35	1.00	16.0 to 18.0	5.0 to 6.5	1.75 to 2.25	0.50 max <sup>B</sup>
A1	S20300	XM1 <sup>A</sup>	0.08	5.0 to 6.5	0.040	0.18 to 0.35	1.00	16.0 to 18.0	5.0 to 6.5	1.75 to 2.25	0.50 max <sup>B</sup>
—	S30430	XM7	0.03	2.00	0.045	0.030	1.00	17.0 to 19.0	8.0 to 10.0	3.00 to 4.00	...
A1	S30430	18-9LW	0.10	2.00	0.045	0.030	1.00	17.0 to 19.0	8.0 to 10.0	3.00 to 4.00	...
A1	S30433	302HQ	0.03	2.00	0.045	0.030	1.00	17.0 to 19.0	8.0 to 10.0	3.0 to 4.0	...
A1	S30433	302HQ	0.03	2.00	0.045	0.030	1.00	17.0 to 19.0	8.0 to 10.0	3.0 to 4.0	...
A1	S31600	316	0.08	2.00	0.045	0.030	1.00	16.0 to 18.0	10.0 to 14.0	...	2.0 to 3.0
A1	S31600	316	0.08	2.00	0.045	0.030	1.00	16.0 to 18.0	10.0 to 14.0	...	2.0 to 3.0
—	S31603	316L	0.03	2.00	0.045	0.030	1.00	16.0 to 18.0	10.0 to 14.0	...	2.0 to 3.0
A1	S31603	316L	0.03	2.00	0.045	0.030	1.00	16.0 to 18.0	10.0 to 14.0	...	2.0 to 3.0
Martensitic Alloys											
G1-110	S4100	410	0.15	1.00	0.040	0.030	1.00	11.5 to 13.5	...	...	...
C1	S4100	410	0.15	1.00	0.040	0.030	1.00	11.5 to 13.5	...	...	...

<sup>A</sup> Free machining grades are not recommended for forged product. These grades may be furnished only when approved by the purchaser.

<sup>B</sup> At manufacturer's option, determined only when intentionally added.

**TABLE 3 Mechanical Testing Requirements**

Item	Product Length	Hardness		Test conducted Using Full Size Product		Test Conducted Using Machined Test Specification		
		max	min	Extension	Axial Tensile Strength	Yield Strength 0.2 % offset	Tensile Strength	Elongation
1	≤3 D <sup>A</sup>	B	B	...	B	...	...	...
2	3 D to 300 mm	B	...	B	B	...	...	...
3	Over 300 mm	B	...	A	A	B	B	B

<sup>A</sup> D denotes nominal diameter of product.

<sup>B</sup> Denotes mandatory test. In addition, either all tests denoted by A or all tests denoted by B shall be performed. In case of arbitration, full-size tests, denoted A, shall be decisive.

## 10. Dimensions

10.1 Unless otherwise specified, the products shall conform to the requirements of ASME B18.3.1M Hexagon Socket Head Cap Screws (Metric Series).

## 11. Workmanship, Finish, and Appearance

11.1 *Surface Treatment*—Unless otherwise specified, screws shall be cleaned, descaled and passivated in accordance with Practice A 380 or Specification A 967 at the option of the manufacturer.

11.2 The surface discontinuities for these products shall conform to Specification F 788/F 788M and the additional limitations specified herein.

11.2.1 Forging defects that connect the socket to the periphery of the head are not permissible. Defects originating on the periphery and with a traverse indicating a potential to intersect are not permissible. Other forging defects are permissible provided those located in the bearing area, fillet, and top surfaces shall not have a depth exceeding 0.03 D or 0.13 mm, whichever is greater. For peripheral discontinuities, the maximum depth may be 0.06 D (see Fig. 1).

11.2.2 Forging defects located in the socket wall within 0.1 times the actual key engagement, T, from the bottom of the socket are not permissible. Discontinuities located elsewhere in the socket shall not have a length exceeding 0.25 T, or a maximum depth of 0.03 D not to exceed 0.13 mm (see Fig. 2).

11.2.3 Seams in the shank shall not exceed a depth of 0.03 D or 0.2 mm, whichever is greater.

11.2.4 No transverse discontinuities shall be permitted in the head-to-shank fillet area.

11.2.5 Threads shall have no laps at the root or on the flanks, as shown in Fig. 3. Laps are permitted at the crests (Fig. 3c) that do not exceed 25 % of the basic thread depth, and on the flanks outside the pitch cylinder. Longitudinal seams rolled beneath the root of the thread and across the crests of cut threads are acceptable within the limits of 11.2.3.

**TABLE 4 Tensile Strength Values for Full Size Fasteners, kN**

Nominal Size and Thread Pitch	Stress Area, mm <sup>2</sup> <sup>A</sup>	Property Classes			
		Property Class A1-50	Property Class A1-50	Property Class A1-70	Property Class A1-110
		Tensile Strength, kN <sup>B</sup>	Tensile Strength, kN <sup>C</sup>	Tensile Strength, kN <sup>D</sup>	Tensile Strength, kN <sup>E</sup>
M1.6 × 0.35	4.27	0.64		0.84	1.40
M1.6 × 0.35	1.27	0.74	0.70	0.89	1.40
M2 × 0.4	2.07	1.04		1.38	2.28
M2 × 0.4	2.07	1.21	1.14	1.45	2.28
M2.5 × 0.45	3.39	1.70		2.25	3.73
M2.5 × 0.45	3.39	1.98	1.87	2.37	3.73
M3 × 0.5	5.03	2.52		3.35	5.53
M3 × 0.5	5.03	2.94	2.77	3.52	5.53
M3.5 × 0.6	6.78	3.97	3.73	4.75	7.46
M4 × 0.7	8.78	4.39		5.84	9.66
M4 × 0.7	8.78	5.14	4.83	6.15	9.66
M5 × 0.8	14.2	7.10		9.44	15.6
M5 × 0.8	14.2	8.30	7.80	9.93	15.6
M6 × 1	20.1	10.1		13.4	22.1
M6 × 1	20.1	11.8	11.1	14.1	22.1
M8 × 1.25	36.6	18.3		24.3	40.3
M8 × 1.25	36.6	21.4	20.1	25.6	40.3
M10 × 1.5	58.0	29.0		38.6	63.8
M10 × 1.5	58.0	33.9	31.9	40.6	63.8
M12 × 1.75	84.3	42.2		56.1	92.7
M12 × 1.75	84.3	49.3	46.3	59.0	92.7
M14 × 2	115	67.5	63.5	80.8	126.5
M16 × 2	157	78.5		86.4	173
M16 × 2	157	91.7	86.2	110	173
M20 × 2.5	245	123		135	270
M20 × 2.5	245	143	135	171	270
M24 × 3	353	177		194	388
M24 × 3	353	206	...	...	388
M30 × 3.5	561	281		309	617
M30 × 3.5	561	328	...	...	617
M36 × 4	817	409		449	899
M36 × 4	817	478	...	...	899

<sup>A</sup> Stress Area = 0.7854 ( D - 0.9382P)<sup>2</sup>

where:

D = nominal thread diameter, mm, and

P = thread pitch, mm.

<sup>B</sup> Tensile based on stress area and 500 MPa.

<sup>C</sup> Tensile based on stress area and 665 MPa through M 14 and 550 MPa M 16 and above.

<sup>D</sup> Tensile based on stress area and 700 MPa minimum through M20.

<sup>E</sup> Tensile based on stress area and 1100 MPa.

## 12. Number of Tests

12.1 The requirements of this specification shall be met in continuous mass production for stock and the manufacturer shall make sample inspections to ensure that the product conforms to the specified requirements. Additional tests of individual shipments of fasteners are not ordinarily necessary. A record of the individual heat of steel in each lot shall be maintained. The containers shall be coded to permit identification of the lot.

12.2 When specified in the purchase order, the manufacturer shall furnish a test report of the last complete set of chemical analysis and mechanical tests for each stock size in each shipment.

12.3 When tests of individual shipments are required, Supplementary Requirement S1 must be specified in the inquiry and order.

12.3.1 When the purchaser does not specify the sampling plan and basis of acceptance, the following shall apply:

12.3.1.1 The lot, for purposes of selecting samples, shall consist of all products offered for inspection and testing, at one time, that are the same type, style, nominal diameter, thread pitch, nominal length, material (alloy), property class, and surface finish.

12.3.1.2 From each lot, samples shall be selected at random and tested for each requirement in accordance with the following plan:

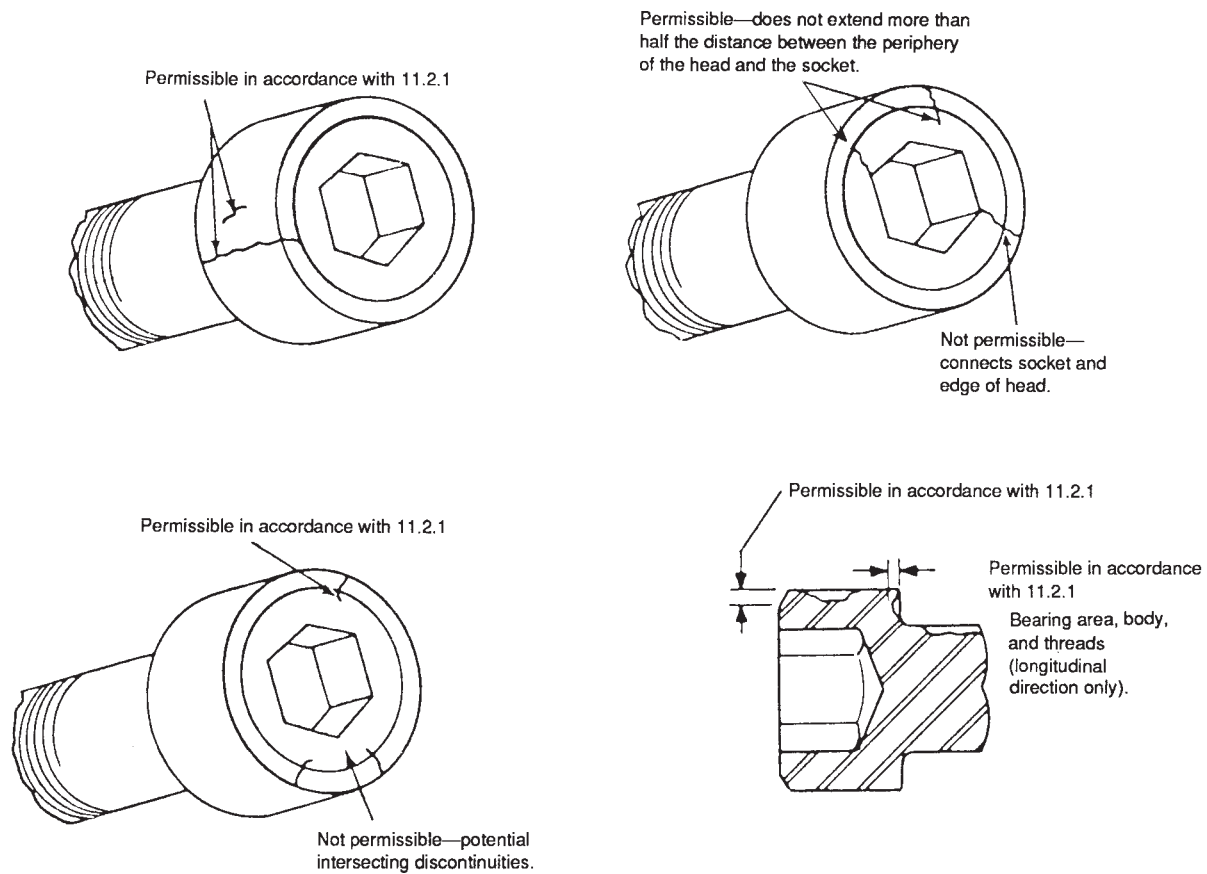

FIG. 1 Head and Body Discontinuity Location and Limits

Number of Pieces in Lot	Number of Samples
800 and less	1
Over 800 to 8000, incl	2
Over 8000 to 22 000, incl	3
Over 22 000	5

12.3.1.3 Should any sample fail to meet the requirements of a specified test, double the number of samples from the same lot shall be retested for the requirement(s) in which it failed. All of the additional samples shall conform to the specification or the lot shall be rejected.

12.3.1.4 If the failure of a test specimen is due to improper preparation of the specimen or an incorrect testing technique, the specimen shall be discarded and another test specimen submitted.

12.4 Corrosion Resistance Tests:

12.4.1 Unless otherwise specified, inspection for corrosion resistance shall be in accordance with the manufacturer’s standard quality control practices. No specific method of inspection is required but the screws shall be produced from suitable raw material and manufactured by properly controlled practices to maintain resistance to corrosion. When corrosion tests are required, Supplementary Requirement S5 must be specified in the inquiry and order, except as noted in 12.4.2.

12.4.2 Products that have been hot worked shall be solution annealed and tested to determine freedom from precipitated carbides. Not less than one corrosion test shall be made from each lot. Corrosion tests shall be performed in accordance with Practices A 262, Practices A or E as applicable.

13. Test Methods

13.1 Chemical Analysis—The chemical composition shall be determined in accordance with Test Method A 751.

13.1.1 The fastener manufacturer may accept the chemical analysis of each heat of raw material purchased and reported on the raw material certification furnished by the raw material producer. The fastener manufacturer is not required to do any further chemical analysis testing provided that precise heat lot traceability has been maintained throughout the manufacturing process on each lot of fasteners produced and delivered.

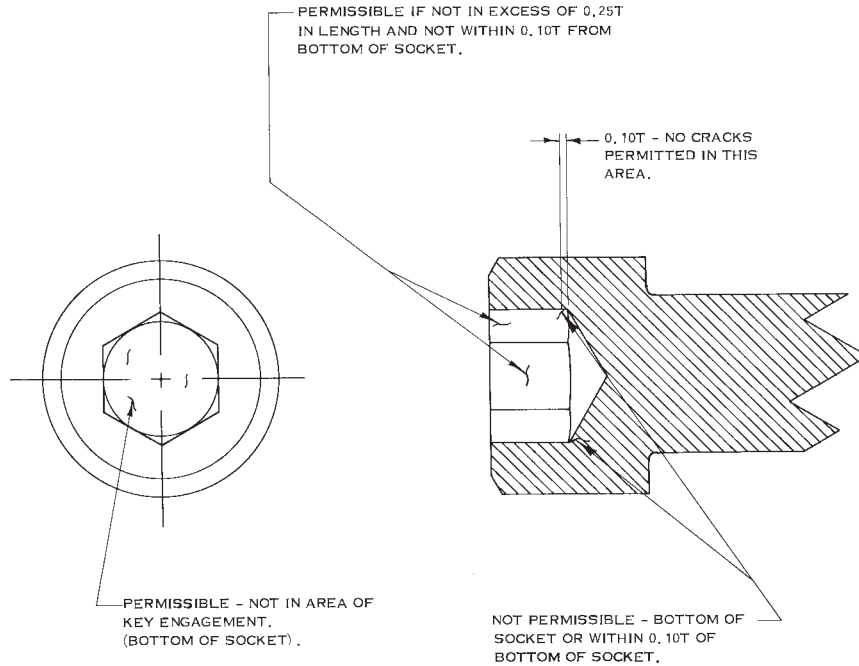

FIG. 2 Socket Discontinuity Location and Limits

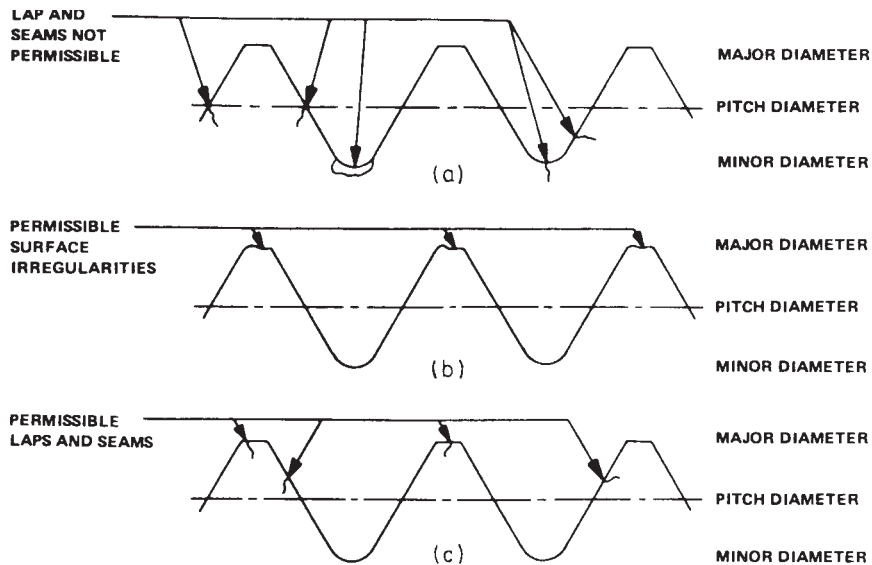

FIG. 3 Thread Discontinuities

13.2 Mechanical Tests:

13.2.1 Screws tested full size for axial strength, screw extension, and hardness shall be tested in accordance with the methods described in Test Methods F 606M and 13.2.3 of this specification. The hardness shall be determined using Test Methods E 18, E 92, or E 384, as appropriate.

13.2.2 Machined test specimens tested for tensile strength, yield strength at 0.2 % offset, and elongation shall be tested in accordance with the methods described in Test Methods F 606M.

13.2.3 Extension Test is applicable only to full size products. The overall length of the test specimen ( $L_1$ ) shall be measured within  $\pm 0.12$  mm. The head end reference surface for length measurement may be the bottom of the hex socket for measuring purposes. The specimen shall be assembled into a threaded adapter to a depth of one nominal diameter and then axial tensile tested in accordance with 13.2.1 to failure. The two broken pieces shall be fitted closely together and the overall length ( $L_2$ ) measured again. The total extension shall be computed by subtracting the original overall length from the length following fracture (Fig. 4). The product is acceptable when the extension equals or exceeds the minimum value for extension specified in Table 1.

13.3 Corrosion Resistance—When specified on the purchase order or inquiry, corrosion tests to determine freedom from precipitated carbides shall be performed in accordance with Practices A 262, Practice A or E as applicable.



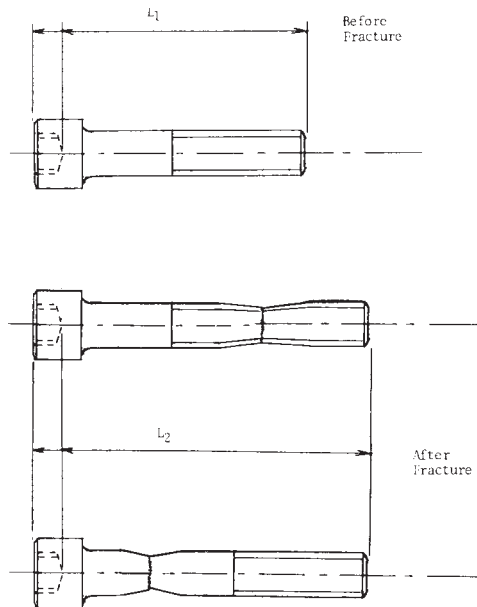

FIG. 4 Comparison of Overall Length Before and After Fracture

#### 14. Inspection

14.1 If the inspection described in 14.2 is required by the purchaser, it shall be specified in the inquiry, order, or contract.

14.2 The inspector representing the purchaser shall have free entry to all parts of the manufacturer's works that concern the manufacture of the material ordered. The manufacturer shall afford the inspector all reasonable facilities to satisfy that the material is being furnished in accordance with this specification. All tests and inspection required by the specification that are requested by the purchaser's representative and purchase order shall be made prior to shipment, and shall be so conducted as not to interfere unnecessarily with the operation of the work.

#### 15. Rejection and Rehearing

15.1 Screws that fail to conform to the requirements of this specification may be rejected by the purchaser. Rejection shall be reported to the supplier promptly and in writing. In case of dissatisfaction with the results of tests or inspection authorized by the purchaser, the supplier may claim for a rehearing.

#### 16. Certification

16.1 *Test Report*— The manufacturer shall maintain on file for a period of 5 years the original test report, including a copy of the certified chemical analysis of the heat of material used and the results of the required testing for the lot of fasteners.

16.2 *Manufacturer's Certificate of Conformance*—The manufacturer shall maintain on file for a period of 5 years, a certificate indicating that the lot of fasteners was manufactured and tested in accordance with this specification and conforms to all specified requirements.

16.3 When requested by the purchaser, submission of copies of the test report, manufacturer's certificate or an extension of the 5-year document retention period shall be performed as agreed between the manufacturer and the purchaser at the time of the inquiry or order.

#### 17. Product Marking

17.1 Screws, of nominal thread diameters M5 and larger, shall be marked to identify the property class and the manufacturer. The property class symbol shall be as given below. The manufacturer's insignia shall be of his design. Markings may be on the side or top of the head and shall be readable with no greater than 10× magnification.

Alloy Grade	Product Identification	Property Class Symbol
A1		A1-50
A1		A1-55
A1		A1-70
C1		C1-110

#### 18. Packaging and Package Marking

18.1 *Packaging:*

18.1.1 Unless otherwise specified, packaging shall be in accordance with Practice D 3951.

18.1.2 When special packaging requirements are required by the purchaser, they shall be defined at the time of inquiry and order.



18.2 *Package Marking*—Each shipping unit shall include or be plainly marked with the following:

- 18.2.1 ASTM specification,
- 18.2.2 Property class symbol,
- 18.2.3 Alloy number,
- 18.2.4 Size,
- 18.2.5 Name and brand or trademark of the manufacturer,
- 18.2.6 Country of origin,
- 18.2.7 Number of pieces, and
- 18.2.8 Purchase order number.

## **19. Keywords**

- 19.1 corrosion resistance; stainless steel; socket head cap screws

## **SUPPLEMENTARY REQUIREMENTS**

One or more of the following supplementary requirements shall apply only when specified by the purchaser in the inquiry and order (see 4.1.6). Supplementary requirements shall in no way negate any requirement of the specification itself.

### **S1. Shipment Lot Testing**

S1.1 When Supplementary Requirement S1 is specified on the order, the manufacturer shall make sample tests on the individual lots for shipment to ensure that the product conforms to the specified requirements.

S1.2 The manufacturer shall make an analysis of a randomly selected finished fastener from each lot of product to be shipped. Heat or lot control shall be maintained. The analysis of the starting material from which the fasteners have been manufactured may be reported in place of the product analysis.

S1.3 The manufacturer shall perform mechanical property tests in accordance with this specification and Guide F 1470 on the individual lots for shipment.

S1.4 The manufacturer shall furnish a test report for each lot in the shipment showing the actual results of the chemical analysis and mechanical property tests performed in accordance with Supplementary Requirement S1.

### **S2. Alloy Control**

S2.1 When Supplementary Requirement S2 is specified on the inquiry and order, the manufacturer shall supply that alloy specified by the customer on his order with no group substitutions permitted without the written permission of the purchaser.

### **S3. Permeability**

S3.1 When Supplementary Requirement S3 is specified on the inquiry and order, the permeability of screws of Property Class A1-50 screws shall not exceed 1.05 at 100 oersteds when determined by Test Method A 342. Screws in ~~product~~ Property Class A1-55 or A1-70 may not be capable of meeting permeability and strength requirements simultaneously. Consultation with the raw material manufacturer should be considered for critical permeability requirements.

### **S4. Material Identification**

S4.1 When Supplementary Requirement S4 is specified on the inquiry and order for nominal sizes M5 (5 mm) and larger, the fasteners shall be marked with the specific alloy number to identify the material in accordance with the purchaser's instructions, and with the manufacturer's insignia. The manufacturer's identification insignia shall be of the design, placed on the side or top of the head and known and recognizable to the purchaser. The insignia shall be readable with no greater than 10× magnification.

### **S5. Corrosion Resistance Tests**

S5.1 When Supplementary Requirement S5 is specified on the inquiry and order, corrosion test(s) shall be performed as agreed between the manufacturer and the purchaser at the time of the inquiry or order.

### **S6. Passivation**

S6.1 When Supplementary Requirement S6 is specified on the inquiry and order, the finished product shall be passivated in accordance with Specification A 380.

 **F 837M – 012a**

*ASTM International takes no position respecting the validity of any patent rights asserted in connection with any item mentioned in this standard. Users of this standard are expressly advised that determination of the validity of any such patent rights, and the risk of infringement of such rights, are entirely their own responsibility.*

*This standard is subject to revision at any time by the responsible technical committee and must be reviewed every five years and if not revised, either reapproved or withdrawn. Your comments are invited either for revision of this standard or for additional standards and should be addressed to ASTM International Headquarters. Your comments will receive careful consideration at a meeting of the responsible technical committee, which you may attend. If you feel that your comments have not received a fair hearing you should make your views known to the ASTM Committee on Standards, at the address shown below.*

*This standard is copyrighted by ASTM International, 100 Barr Harbor Drive, PO Box C700, West Conshohocken, PA 19428-2959, United States. Individual reprints (single or multiple copies) of this standard may be obtained by contacting ASTM at the above address or at 610-832-9585 (phone), 610-832-9555 (fax), or [service@astm.org](mailto:service@astm.org) (e-mail); or through the ASTM website ([www.astm.org](http://www.astm.org)).*