



Designation: F 879 – 02

## Standard Specification for Stainless Steel Socket Button and Flat Countersunk Head Cap Screws<sup>1</sup>

This standard is issued under the fixed designation F 879; the number immediately following the designation indicates the year of original adoption or, in the case of revision, the year of last revision. A number in parentheses indicates the year of last reapproval. A superscript epsilon ( $\epsilon$ ) indicates an editorial change since the last revision or reapproval.

*This standard has been approved for use by agencies of the Department of Defense.*

### 1. Scope

1.1 This specification covers the chemical and mechanical requirements for stainless steel inch hexagon socket button (SBHCS) and flat countersunk (SFHCS) head cap screws with nominal thread 0.060 through 0.625 in. intended for use in applications requiring general corrosion resistance.

1.2 The following two conditions are covered:

1.2.1 Austenitic alloy condition AF in an annealed condition at 85 ksi maximum and

1.2.2 Austenitic alloy condition CW in a cold-worked condition at 95 ksi minimum.

1.3 The following precautionary caveat pertains only to the test method portion, Section 12, of this specification: *This standard does not purport to address all of the safety concerns, if any, associated with its use. It is the responsibility of the user of this standard to establish appropriate safety and health practices and determine the applicability of regulatory limitations prior to use.*

### 2. Referenced Documents

#### 2.1 ASTM Standards:

A 262 Practices for Detecting Susceptibility to Intergranular Attack in Austenitic Stainless Steels<sup>2</sup>

A 342 Test Methods for Permeability of Feebly Magnetic Materials<sup>3</sup>

A 380 Practice for Cleaning, Descaling, and Passivation of Stainless Steel Parts, Equipment, and Systems<sup>2</sup>

A 555/A555M Specification for General Requirements for Stainless Steel Wire and Wire Rods<sup>2</sup>

A 751 Test Methods, Practices, and Terminology for Chemical Analysis of Steel Products<sup>2</sup>

A 967 Specification for Chemical Passivation Treatments

<sup>1</sup> This specification is under the jurisdiction of ASTM Committee F16 on Fasteners and is the direct responsibility of Subcommittee F16.04 on Nonferrous Fasteners.

Current edition approved June 10, 2002. Published June 2002. Originally published as F 879 – 86. Last previous edition F 879 – 01.

<sup>2</sup> Annual Book of ASTM Standards, Vol 01.03.

<sup>3</sup> Annual Book of ASTM Standards, Vol 03.04.

for Stainless Steel Parts<sup>2</sup>

D 3951 Practice for Commercial Packaging<sup>4</sup>

F 593 Specification for Stainless Steel Bolts, Hex Cap Screws, and Studs<sup>5</sup>

F 606 Test Methods for Determining the Mechanical Properties of Externally and Internally Threaded Fasteners, Washers, and Rivets<sup>5</sup>

F 788/F 788M Specification for Surface Discontinuities of Bolts, Screws, and Studs, Inch and Metric Series<sup>5</sup>

F 1470 Guide for Fastener Sampling for Specified Mechanical Properties and Performance Inspection<sup>5</sup>

#### 2.2 ASME Standard:

B 18.3 Socket Cap, Shoulder and Set Screws (Inch Series)<sup>6</sup>

### 3. Classification

3.1 The designation of the alloy group and condition of this specification shall be consistent with the stainless steel designations in Specification F 593.

3.2 The austenitic stainless steel socket screw shall be designated F 879 Group 1 Condition AF or F 879 Group 1 Condition CW.

### 4. Ordering Information

4.1 Orders for material under this specification shall include the following information:

4.1.1 Quantity (number of pieces of each item).

4.1.2 Name of the screw, SBHCS or SFHCS.

4.1.3 Dimensions, including nominal thread designation, thread pitch, and nominal screw length (inches). A standard part number may be used for this definition.

4.1.4 Alloy group, and condition (Group 1 AF or Group 1 CW).

4.1.5 Certification, if required (see Section 15).

4.1.6 ASTM specification and year of issue.

<sup>4</sup> Annual Book of ASTM Standards, Vol 15.09.

<sup>5</sup> Annual Book of ASTM Standards, Vol 01.08.

<sup>6</sup> Available from Global Engineering Documents, 15 Inverness Way East, Englewood, CO 80112.



4.1.7 Any special or supplemental requirements (see Supplementary Requirements S1 through S6).

## 5. Materials and Manufacture

5.1 Screws shall be formed by upsetting or extruding, or both.

5.2 Screws shall be roll threaded.

5.3 *Heat Treatment*—Austenitic alloys Condition AF screws, following manufacture, shall be annealed by heating to  $1900 \pm 50^\circ\text{F}$  to obtain maximum corrosion resistance and minimum permeability. The screws shall be held for a sufficient time at temperature, then cooled at a rate sufficient to prevent precipitation of the carbide and provide the properties specified in Table 1.

5.4 When Condition CW is specified, the austenitic alloys shall be annealed as specified in 5.3, generally by the raw material manufacturer, then cold worked to develop specific properties.

## 6. Chemical Composition

6.1 It is the intent of this specification that screws shall be ordered by alloy condition. The chemical composition of the screws shall conform to the requirements of Table 2.

6.2 Unless otherwise specified in the inquiry and purchase order (see Supplementary Requirement S2) when CW or AF condition property class is specified, the choice of stainless steel used shall be that of the fastener manufacturer as determined by his fabrication methods and material availability. The specific stainless steel used by the manufacturer shall be clearly identified on all certification required in the purchase order and shall have a chemical composition conforming to the limits specified in Table 2.

6.3 When chemical analysis is performed by the purchaser using finished fasteners, the chemical composition obtained shall conform to the limits specified in Table 2 for the specific alloy. Chemical composition shall conform to the tolerances specified in Specification A 555.

6.3.1 In the event of a discrepancy, a referee analysis of the samples for each lot as specified in 12.1 shall be made in accordance with 11.3.1.

## 7. Mechanical Properties

7.1 The finished screws shall conform to the mechanical requirements specified in Table 1.

7.2 Screws having a nominal length equal to or greater than three diameters shall be tensile tested full size and shall meet the full size breaking strength requirements specified in Table 3. Tensile failures through the head are acceptable providing the load requirements are satisfied.

7.3 Screws that are too short (lengths less than specified in 7.2 or that have insufficient threads for tension testing) shall

not be subject to tension tests, but shall conform to the maximum and minimum hardness requirements of Table 1.

## 8. Corrosion Resistance Requirements

### 8.1 Carbide Precipitation:

8.1.1 Rod, bar, and wire in the austenitic alloy group 1 used to make fasteners in accordance with this specification shall be capable of passing the test for susceptibility to intergranular corrosion as specified in Practice E of Practices A 262.

8.1.2 As stated in Practices A 262, samples may be subjected to the faster and more severe screening test in accordance with Practice A. Failing Practice A, specimens shall be tested to Practice E and be considered satisfactory if passing Practice E.

## 9. Dimensions

9.1 Unless otherwise specified, the dimensions shall conform to the requirements of ASME B18.3.

## 10. Workmanship and Finish

10.1 *Surface Treatment*—Unless otherwise specified, screws shall be cleaned, descaled, and passivated in accordance with Practice A 380 or Specification A 967 at the option of the manufacturer.

### 10.2 Surface Discontinuities:

10.2.1 The surface discontinuities for these products shall conform to Specification F 788/F 788M and the additional limitations specified herein.

10.2.1.1 Forging defects that connect the socket to the periphery of the head are not permissible. Defects originating on the periphery and with a traverse indicating a potential to intersect are not permissible. Other forging defects are permissible provided those located in the bearing area, fillet, and top surfaces shall not have a depth exceeding  $0.03 D$  or  $0.005$  in. whichever is greater. For peripheral discontinuities, the maximum depth may be  $0.06 D$  (see Fig. 1).

10.2.1.2 Forging defects located in the socket wall within  $0.1$  times the actual key engagement,  $T$ , from the bottom of the socket are not permissible. Discontinuities located elsewhere in the socket shall not have a length exceeding  $0.25 T$ , or a maximum depth of  $0.03 D$  not to exceed  $0.005$  in. (see Fig. 2).

10.2.1.3 Seams in the shank shall not exceed a depth of  $0.03 D$  or  $0.008$  in. whichever is greater.

10.2.1.4 No transverse discontinuities shall be permitted in the head-to-shank fillet area.

10.2.1.5 Threads shall have no laps at the root or on the flanks, as shown in Fig. 3. Laps are permitted at the crests (Fig. 3(C)) that do not exceed 25 % of the basic thread depth, and on the flanks outside the pitch cylinder. Longitudinal seams rolled beneath the root of the thread and across the crests of the threads are acceptable within the limits of 10.2.1.3.

**TABLE 1 Mechanical Property Requirements**

Alloy Condition	Full Size Product Tests		Machined Specimen Tests			Hardness			
	Tensile Strength ksi	Extension min	Tensile Strength ksi	Yield Strength ksi	Elongation % min	Vickers		Rockwell	
						min	max	min	max
AF	85 max	0.6D	80 max	50 max	40	...	170	...	B85
CW	90 min	0.4D	85 min	58 min	20	220	330	B80	C33

**TABLE 2 Alloy Group 1 Chemical Requirements**

UNS Designation	Alloy	Composition, % maximum except as shown							
		Carbon	Manganese	Phosphorus	Sulfur	Silicon	Chromium	Nickel	Copper
Austenitic Alloys									
S30400	304	0.08	2.00	0.045	0.030	1.00	18.0 to 20.0	8.0 to 10.5	1.00
S30403	304L	0.030	2.00	0.045	0.030	1.00	18.0 to 20.0	8.0 to 12.0	1.00
S30500	305	0.12	2.00	0.045	0.030	1.00	17.0 to 19.0	10.5 to 13.0	1.00
S38400	384	0.08	2.00	0.045	0.030	1.00	15.0 to 17.0	17.0 to 19.0	...
S30430	18-9LW	0.10	2.00	0.045	0.030	1.00	17.0 to 19.0	8.0 to 10.0	3.0 to 4.0
S30433	302HQ	0.03	2.00	0.045	0.030	1.00	17.0 to 19.0	8.0 to 10.0	3.0 to 4.0
S31600	316	0.08	2.00	0.045	0.030	1.00	16.0 to 18.0	10.0 to 14.0	...
S31603	316L	0.03	2.00	0.045	0.030	1.00	16.0 to 18.0	10.0 to 14.0	...

**TABLE 3 Breaking Strength Values for Full Size Fasteners**

NOTE 1—Breaking loads are based on tensile stress area and strengths of 85 ksi max (AF) and 76 ksi min (CW). The minimum loads for CW condition are based on the tensile properties of 95 ksi material strength, reduced by 20 % to allow for the head critical nature of these configurations.

Nominal Size	Tensile Stress Area, in. <sup>2</sup>	Alloy Condition		
		AF, lb, max	CW, lb, min	
0	0.060–80	0.00180	153	137
1	0.073–64	0.00263	224	200
2	0.086–56	0.00370	255	280
3	0.099–48	0.00487	414	370
4	0.112–40	0.00604	513	460
5	0.125–44	0.00796	676	600
6	0.138–32	0.00909	772	690
8	0.164–32	0.0140	1190	1060
10	0.190–24	0.0175	1487	1330
¼	0.250–20	0.0318	2703	2420
⅜	0.312–18	0.0524	4454	3980
½	0.375–16	0.0775	6588	5890
⅝	0.500–13	0.1419	12 061	10 800
¾	0.625–11	0.226	19 210	17 200

**11. Number of Tests**

11.1 The requirements of this specification shall be met in continuous mass production for stock and the manufacturer shall make sample inspections to ensure that the product conforms to the specified requirements. Additional tests of individual shipments of fasteners are not ordinarily necessary. A record of the individual heat of steel in each lot shall be maintained. The containers shall be coded to permit identification of the lot.

11.2 When specified in the purchase order, the manufacturer shall furnish a test report of the last complete set of chemical analysis and mechanical tests for each stock size in each shipment.

11.3 When tests of individual shipments are required, Supplementary Requirement S1 must be specified in the inquiry and order.

11.3.1 When the purchaser does not specify the sampling plan and basis of acceptance, the following shall apply:

11.3.1.1 The lot, for purposes of selecting samples, shall consist of all products offered for inspection and testing at one time that are of the same type, style, nominal diameter, thread pitch, nominal length, material, condition, and surface finish.

11.3.1.2 From each lot, samples shall be selected at random and tested for each requirement in accordance with the following:

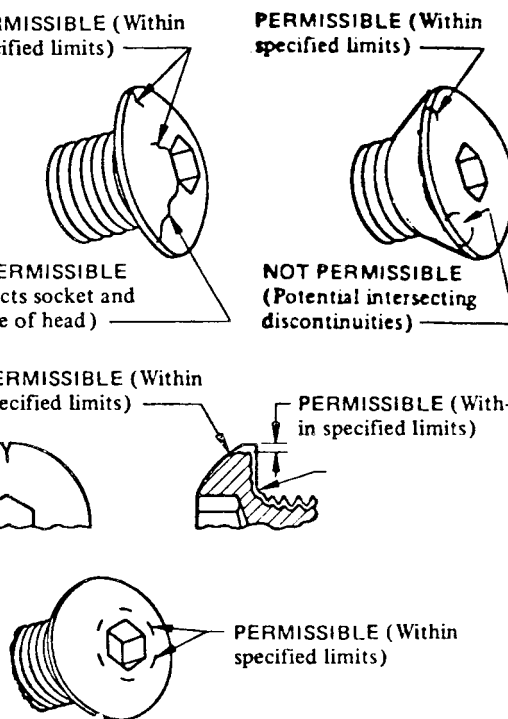

**FIG. 1 Head Discontinuities (See 10.2.1)**

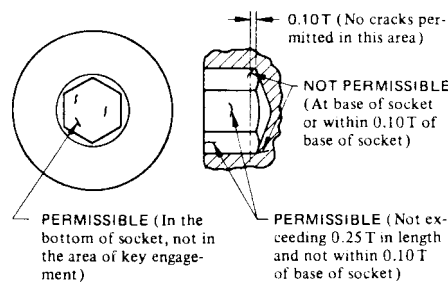

**FIG. 2 Socket Discontinuities (See 10.2.1)**

Number of Pieces in Lot	Number of Samples
800 and less	1
Over 800 to 8000, incl	2
Over 8000 to 22 000, incl	3
Over 22 000	5

11.3.1.3 Should any sample fail to meet the requirements of a specified test, double the number of samples from the same lot shall be retested for the requirement(s) in which it failed. All of the additional samples shall conform to the specification, or the lot shall be rejected.

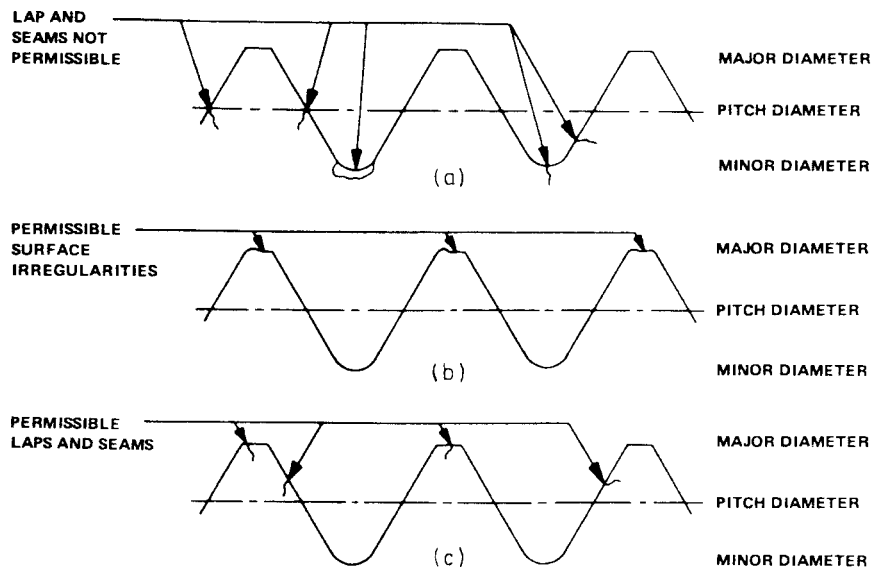

**FIG. 3 Thread Discontinuities**

11.3.1.4 If the failure of a test specimen is due to improper preparation of the specimen or an incorrect testing technique, the specimen shall be discarded and another test specimen submitted.

**11.4 Corrosion Resistance Tests:**

11.4.1 Unless otherwise specified, inspection for corrosion resistance shall be in accordance with the manufacturer's standard quality control practices. No specific method of inspection is required but the screws shall be produced from suitable raw material and manufactured by properly controlled practices to maintain resistance to corrosion. When corrosion tests are required, Supplementary Requirement S5 must be specified in the inquiry and order, except as noted in 11.4.2.

11.4.2 Products that have been hot worked shall be solution annealed and tested to determine freedom from precipitated carbides. Not less than one corrosion test shall be made from each lot. Corrosion tests shall be performed in accordance with Practices A 262, Practices A or E as applicable.

**12. Test Methods**

12.1 *Chemical Analysis*—The chemical composition shall be determined in accordance with Test Method A 751.

12.1.1 The fastener manufacturer may accept the chemical analysis of each heat of raw material purchased and reported on the raw material certification furnished by the raw material producer. The fastener manufacturer is not required to do any further chemical analysis testing provided that precise heat lot traceability has been maintained throughout the manufacturing process on each lot of fasteners produced and delivered.

**12.2 Mechanical Tests:**

12.2.1 Screws tested for axial strength, screw extension, or hardness shall be tested in accordance with the methods described in Test Methods F 606 and of this specification.

12.2.2 Machined test specimens tested for tensile strength, yield strength at 0.2 % offset and elongation, shall be tested in accordance with the methods described in Test Methods F 606.

12.2.3 *Extension Test*—An extension test is applicable only to full-size products. The overall length of the test specimen,

$L_1$ , shall be measured within  $\pm 0.005$  in. The head-end reference surface for length measurement may be the bottom of the hex socket for measuring purposes. The specimen shall be assembled into a threaded adapter to a depth of one nominal diameter, then axial tensile shall be tested in accordance with 12.2.1 to failure. The two broken pieces shall be fitted closely together and the overall length,  $L_2$ , measured again. The total extension shall be computed by subtracting the original overall length from the following fracture (Fig. 4). The product is acceptable when the extension equals or exceeds the minimum value for extension specified in Table 1.

12.3 *Corrosion Resistance*—When specified on the purchase order or inquiry, corrosion tests to determine freedom

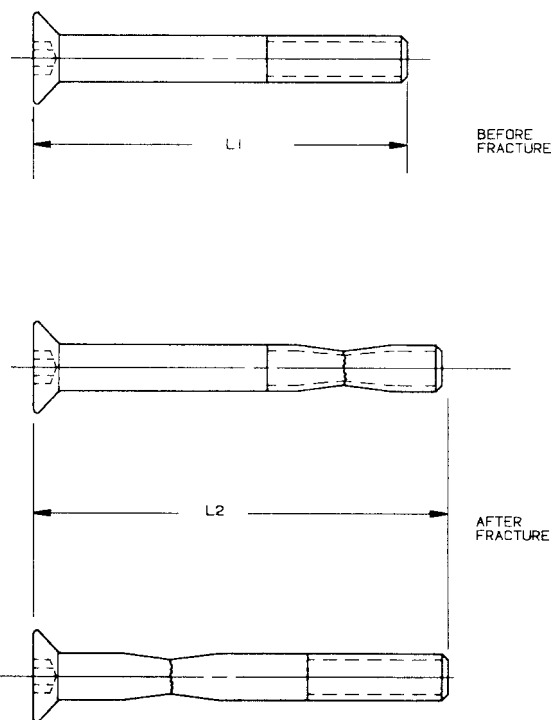

**FIG. 4 Test Specimen-Extension Test**



from precipitated carbides shall be performed in accordance with Practices A 262, Practice A or E as applicable.

### **13. Inspection**

13.1 If the inspection described in 13.2 is required by the purchaser, it shall be specified in the inquiry, order, or contract.

13.2 The inspector representing the purchaser shall have free entry to all parts of the manufacturer's works that concern the manufacture of the material ordered. The manufacturer shall afford the inspector all reasonable facilities to satisfy that the material is being furnished in accordance with this specification. All tests and inspection required by the specification that are requested by the purchaser's representative and purchase order shall be made prior to shipment, and shall be so conducted as not to interfere unnecessarily with the operation of the work.

### **14. Rejection and Rehearing**

14.1 Screws that fail to conform to the requirements of this specification may be rejected by the purchaser. Rejection shall be reported to the supplier promptly and in writing. In case of dissatisfaction with the results of tests or inspection authorized by the purchaser, the supplier may make claim for a rehearing.

### **15. Certification**

15.1 *Test Report*—The manufacturer shall maintain on file for a period of 5 years, the original test report, including a copy of the certified chemical analysis of the heat of material used and the results of the required testing for the lot of fasteners.

15.2 *Manufacturer's Certificate of Conformance*—The manufacturer shall maintain on file for a period of 5 years, a

certificate indicating that the lot of fasteners was manufactured and tested in accordance with this specification and conforms to all specified requirements.

15.3 When requested by the purchaser, submission of copies of the test report, manufacturer's certificate or an extension of the 5-year document retention period shall be performed as agreed between the manufacturer and the purchaser at the time of the inquiry or order.

### **16. Packaging and Package Marking**

#### *16.1 Packaging:*

16.1.1 The manufacturer shall employ such methods of packaging the screws as may be reasonably required to ensure their receipt by the purchaser in a satisfactory condition. Unless otherwise specified, packaging shall be in accordance with Practice D 3951.

16.1.2 When special packaging requirements are required by the purchaser, they shall be defined at the time of inquiry and order.

16.2 *Package Marking*—Each shipping unit shall include or be plainly marked with the following information:

16.2.1 ASTM specification,

16.2.2 Alloy condition,

16.2.3 Alloy number,

16.2.4 Size,

16.2.5 Name and brand or trademark of the manufacturer,

16.2.6 Country of origin,

16.2.7 Number of pieces, and

16.2.8 Purchase order number.

## **SUPPLEMENTARY REQUIREMENTS**

One or more of the following supplementary requirements shall apply only when specified by the purchaser in the inquiry and order (see 4.1.7). Supplementary requirements shall in no way negate any requirement of the specification itself.

### **S1. Shipment Lot Testing**

S1.1 When Supplementary Requirement S1 is specified on the order, the manufacturer shall make sample tests on the individual lots for shipment to ensure that the product conforms to the specified requirements.

S1.2 The manufacturer shall make an analysis of a randomly selected finished fastener from each lot of product to be shipped. Heat or lot control shall be maintained. The analysis of the starting material from which the fasteners have been manufactured may be reported in place of the product analysis.

S1.3 The manufacturer shall perform mechanical property tests in accordance with this specification and Guide F 1470 on the individual lots for shipment.

S1.4 The manufacturer shall furnish a test report for each lot in the shipment showing the actual results of the chemical analysis and mechanical property tests performed in accordance with Supplementary Requirement S1.

### **S2. Alloy Control**

S2.1 When Supplementary Requirement S2 is specified on the inquiry and order, the manufacturer shall supply that stainless steel specified on the customer's order with no substitutions permitted without written permission by the purchaser.

### **S3. Permeability**

S3.1 When Supplementary Requirement S3 is specified on the inquiry and order, the permeability of screws of Condition AF shall not exceed 1.05 at 100 Oe when determined by Test Method A 342. Screws in Condition CW may not be capable of meeting permeability and strength requirements simultaneously.

### **S4. Identification**

S4.1 When Supplementary Requirement S4 is specified on the inquiry and order for nominal sizes  $\frac{1}{4}$  (0.250) in. and larger, the fasteners shall be marked with the manufacturer's





insignia. The manufacturer's identification insignia shall be of the design, placed on the side or top of the head and known and recognizable to the purchaser. The insignia shall be readable at no greater than 10× magnification.

### **S5. Corrosion Resistance Tests**

S5.1 When Supplementary Requirement S5 is specified on the inquiry and order, corrosion test(s) shall be performed as

agreed between the manufacturer and the purchaser at the time of the inquiry or order.

### **S6. Passivation**

S6.1 When Supplementary Requirement S6 is specified on the inquiry and order, the finished product shall be passivated in accordance with Specification A 380.

*ASTM International takes no position respecting the validity of any patent rights asserted in connection with any item mentioned in this standard. Users of this standard are expressly advised that determination of the validity of any such patent rights, and the risk of infringement of such rights, are entirely their own responsibility.*

*This standard is subject to revision at any time by the responsible technical committee and must be reviewed every five years and if not revised, either reapproved or withdrawn. Your comments are invited either for revision of this standard or for additional standards and should be addressed to ASTM International Headquarters. Your comments will receive careful consideration at a meeting of the responsible technical committee, which you may attend. If you feel that your comments have not received a fair hearing you should make your views known to the ASTM Committee on Standards, at the address shown below.*

*This standard is copyrighted by ASTM International, 100 Barr Harbor Drive, PO Box C700, West Conshohocken, PA 19428-2959, United States. Individual reprints (single or multiple copies) of this standard may be obtained by contacting ASTM at the above address or at 610-832-9585 (phone), 610-832-9555 (fax), or service@astm.org (e-mail); or through the ASTM website (www.astm.org).*