



# Standard Specification for Stainless Steel Socket Button and Flat Countersunk Head Cap Screws [Metric]<sup>1</sup>

This standard is issued under the fixed designation F 879M; the number immediately following the designation indicates the year of original adoption or, in the case of revision, the year of last revision. A number in parentheses indicates the year of last reapproval. A superscript epsilon ( $\epsilon$ ) indicates an editorial change since the last revision or reapproval.

*This standard has been approved for use by agencies of the Department of Defense.*

## 1. Scope

1.1 This specification covers the chemical and mechanical requirements for stainless steel metric hexagon socket button (SBHCS) and flat countersunk (SFHCS) head cap screws with nominal thread M 3 through M 20 intended for use in applications requiring general corrosion resistance.

1.2 The following three property classes are covered:

1.2.1 Austenitic Class A 1-50 in an annealed condition at 585 MPa maximum,

1.2.2 Austenitic Class A1–55 in a cold worked condition at 550 MPa minimum, and

1.2.3 Austenitic Class A 1-70 in a cold-worked condition at 700 MPa minimum.

1.3 The following hazard caveat pertains only to Section 12, Test Methods: *This standard does not purport to address all of the safety problems, if any, associated with its use. It is the responsibility of the user of this standard to establish appropriate safety and health practices and determine the applicability of regulatory limitations prior to use.*

## 2. Referenced Documents

### 2.1 ASTM Standards:

A 262 Practices for Detecting Susceptibility to Intergranular Attack in Austenitic Stainless Steels<sup>2</sup>

A 342 Test Methods for Permeability of Feebly Magnetic Materials<sup>3</sup>

A 380 Practice for Cleaning, Descaling, and Passivation of Stainless Steel Parts, Equipment, and Systems<sup>2</sup>

A 555/A555M Specification for General Requirements for Stainless Steel Wire and Wire Rods<sup>2</sup>

A 751 Test Methods, Practices, and Terminology for Chemical Analysis of Steel Products<sup>2</sup>

A 967 Specification for Chemical Passivation Treatments for Stainless Steel Parts<sup>2</sup>

D 3951 Practice for Commercial Packaging<sup>4</sup>

E 18 Test Methods for Rockwell Hardness and Rockwell Superficial Hardness of Metallic Materials<sup>5</sup>

E 92 Test Method for Vickers Hardness of Metallic Materials<sup>5</sup>

E 384 Test Method for Microhardness of Materials<sup>5</sup>

F 606M Test Methods for Determining the Mechanical Properties of Externally and Internally Threaded Fasteners, Washers, and Rivets [Metric]<sup>6</sup>

F 738M Specification for Stainless Steel Metric Bolts, Screws, and Studs<sup>6</sup>

F 788/F788M Specification for Surface Discontinuities of Bolts, Screws, and Studs, Inch and Metric Series<sup>6</sup>

F 1470 Guide for Fastener Sampling for Specified Mechanical Properties and Performance Inspection<sup>6</sup>

### 2.2 ASME Standards:

B 18.3.4M Hexagon Socket Button Head Cap Screws (Metric Series)<sup>7</sup>

B 18.3.5M Hexagon Socket Flat Countersunk Head Cap Screws (Metric Series)<sup>7</sup>

## 3. Classification

3.1 The designation of the property class and conditions of this specification shall be consistent with the stainless steel designations in Specification F 738M.

3.2 The austenitic stainless steel socket screw shall be designated F879M A1-50, F879M A1–55, or F 879M A1-70.

## 4. Ordering Information

4.1 Orders for material under this specification shall include the following information:

4.1.1 Quantity (number of pieces of each item).

<sup>1</sup> This specification is under the jurisdiction of ASTM Committee F16 on Fasteners and is the direct responsibility of Subcommittee F16.04 on Nonferrous Fasteners.

Current edition approved Oct. 10, 2002. Published November 2002. Originally published as F 879 – 84. Last previous edition F 879 – 02.

<sup>2</sup> *Annual Book of ASTM Standards*, Vol 01.03.

<sup>3</sup> *Annual Book of ASTM Standards*, Vol 03.04.

<sup>4</sup> *Annual Book of ASTM Standards*, Vol 15.09.

<sup>5</sup> *Annual Book of ASTM Standards*, Vol 03.01.

<sup>6</sup> *Annual Book of ASTM Standards*, Vol 01.08.

<sup>7</sup> Available from Global Engineering Documents, 15 Inverness Way East, Englewood, CO 80112.

4.1.2 Name of the screw, SBHCS or SFHCS.

4.1.3 Dimensions, including nominal thread designation, thread pitch, and nominal screw length (millimetres). A standard part number may be used for this definition.

4.1.4 Property Class A 1-50, A1-55, or A 1-70.

4.1.5 Certification, if required (see Section 15).

4.1.6 ASTM specification and year of issue.

4.1.7 Any special or supplemental requirements (see Supplementary Requirements S1 through S3).

## 5. Materials and Manufacture

5.1 Screws shall be formed by upsetting or extruding, or both.

5.2 Screws shall be roll threaded.

5.3 *Heat Treatment*—Austenitic alloys Class A 1-50 screws, following manufacture, shall be annealed by heating to  $1040 \pm 30^\circ\text{C}$  to obtain maximum corrosion resistance and minimum permeability. The screws shall be held for a sufficient time at temperature, then cooled at a rate sufficient to prevent precipitation of the carbide and provide the properties specified in Table 1.

5.4 When Property Class A1-55 or A1-70 is specified, the austenitic alloys shall be annealed as specified in 5.3, generally by the raw material manufacturer, then cold worked to develop specific properties.

## 6. Chemical Composition

6.1 It is the intent of this specification that screws shall be ordered by property class. The chemical composition of the screws shall conform to the requirements of Table 2.

6.2 Unless otherwise specified in the inquiry and purchase order (see Supplementary Requirement S2), the choice of stainless steel used shall be that of the fastener manufacturer as determined by his fabrication methods and material availability. The specific stainless steel used by the manufacturer shall be clearly identified on all certification required in the purchase order and shall have a chemical composition conforming to the limits specified in Table 2.

6.3 When chemical analysis is performed by the purchaser using finished fasteners, the chemical composition obtained shall conform to the limits specified in Table 2 for the specific alloy. Chemical composition shall conform to the tolerances specified in Specification A 555/A 555M.

6.3.1 In the event of a discrepancy, a referee analysis of the samples for each lot as specified in 12.1, shall be made in accordance with 11.3.

## 7. Mechanical Properties

7.1 The finished screws shall conform to the mechanical requirements specified in Table 1.

7.2 Screws having a nominal length equal to or greater than three diameters shall be tensile tested full size and shall meet the full size breaking strength requirements specified in Table 3. Tensile failures through the head are acceptable providing the load requirements are satisfied.

7.3 Screws that are too short (lengths less than specified in 7.2 or that have insufficient threads for tension testing) shall not be subject to tension tests, but shall conform to the hardness requirements of Table 1.

## 8. Corrosion Resistance Requirements

### 8.1 Carbide Precipitation:

8.1.1 Austenitic alloy rod, bar, and wire used to make fasteners in accordance with this specification shall be capable of passing the test for susceptibility to intergranular corrosion as specified in Practice E of Practice A 262.

8.1.2 As stated in Practices A 262, samples may be subjected to the faster and more severe screening test in accordance with Practice A. Failing Practice A, specimens shall be tested to Practice E and be considered satisfactory if passing Practice E.

8.1.3 If the fasteners pass the requirements of 8.1.1, they shall be considered acceptable. If they fail, they shall be tested in accordance with Practice C of Practices A 262 and shall show a corrosion rate not exceeding 0.05 mm/month.

## 9. Dimensions

9.1 Unless otherwise specified, the dimensions shall conform to the requirements of ASME B 18.3.4M or ASME B 18.3.5M, as specified.

## 10. Workmanship, Finish, and Appearance

10.1 *Surface Treatment*—Unless otherwise specified, screws shall be cleaned, descaled and passivated in accordance with Practice A380 or Specification A 967 at the option of the manufacturer.

### 10.2 Surface Discontinuities:

10.2.1 The surface discontinuities for these products shall conform to Specification F 788/F 788M and the additional limitations specified herein.

10.2.1.1 Forging defects that connect the socket to the periphery of the head are not permissible. Defects originating on the periphery and with a traverse indicating a potential to

**TABLE 1 Mechanical Property Requirements**

Property Class	Nominal Thread Diameter <sup>A</sup>	Full Size Product Tests		Machined Specimen Tests			Core Hardness <sup>B</sup>	
		Tensile Strength, MPa	Minimum Extension <sup>C</sup>	Tensile Strength, MPa	Yield Strength, MPa	Elongation, %, min	Vickers	Rockwell
A1-50	M3-M20	585 max	0.6D	585 max	380 max	40	210 max	95 HRB max
A1-55	M3-M20	550 min	0.4D	550 min	270 min	25	160 min	50 HRA min
A1-70	M3-M20	700 min	0.4D	600 min	450 min	20	220 min	59 HRA min

<sup>A</sup> Actual full-size testing of Class A1-55 and A1-70 may result in decreased tensile strength because of the head configuration (see Table 3). For fasteners with nominal thread diameters larger than M20, the mechanical properties shall be agreed upon between the user and manufacturer.

<sup>B</sup> Core hardness is only required when full-size product tensile testing cannot be accomplished.

<sup>C</sup> D denotes nominal thread size.

TABLE 2 Chemical Requirements

UNS Designation	Alloy	Composition, % maximum except as shown								
		Carbon	Manganese	Phosphorus	Sulfur	Silicon	Chromium	Nickel	Copper	Molybdenum
S30400	304	0.08	2.00	0.045	0.030	1.00	18.0 to 20.0	8.0 to 10.5	1.00	...
S30403	304L	0.030	2.00	0.045	0.030	1.00	18.0 to 20.0	8.0 to 12.0	1.00	...
S30500	305	0.12	2.00	0.045	0.030	1.00	17.0 to 19.0	10.5 to 13.0	1.00	...
S38400	384	0.08	2.00	0.045	0.030	1.00	15.0 to 17.0	17.0 to 19.0	...	...
S30430	18-9LW	0.10	2.00	0.045	0.030	1.00	17.0 to 19.0	8.0 to 10.0	3.00 to 4.00	...
S30433	302HQ	0.03	2.00	0.045	0.030	1.00	17.0 to 19.0	8.0 to 10.0	3.0 to 4.0	...
S31600	316	0.08	2.00	0.045	0.030	1.00	16.0 to 18.0	10.0 to 14.0	...	2.00 to 3.00
S31603	316L	0.03	2.00	0.045	0.030	1.00	16.0 to 18.0	10.0 to 14.0	...	2.00 to 3.0

TABLE 3 Breaking Strength Values for Full Size Fasteners

NOTE 1—Breaking loads are based on tensile stress area and strengths of 585 MPa max for A1-50, 550 MPa for A1-55, and 700 MPa min A1-70. The minimum loads for property classes A1-55 and A1-70 are reduced by 20 % to allow for the head critical nature of these configurations. See Note A in Table 1. Actual strength of the threaded section, if size permits, may be determined by removing the head and testing the threaded section as a stud.

Nominal Size and Thread Pitch	Stress Area, mm <sup>2</sup>	Property Class		
		A1-50	A1-55	A1-70
		kN, max	kN, min	kN, min
M3 × 0.5	5.03	2.94	2.21	2.82
M4 × 0.7	8.78	5.14	3.86	4.92
M5 × 0.8	14.2	8.30	6.24	7.94
M6 × 1.0	20.1	11.8	8.9	11.3
M8 × 1.25	36.6	21.4	16.1	20.5
M10 × 1.5	58.0	33.9	25.5	32.5
M12 × 1.75	84.3	49.3	37.1	47.2
M14 × 2.0	115.0	67.5	50.8	64.6
M16 × 2.0	157.0	91.7	68.9	87.7
M20 × 2.5	245.0	143	108	137

intersect are not permissible. Other forging defects are permissible provided those located in the bearing area, fillet, and top surfaces shall not have a depth exceeding 0.03 *D* or 0.13 mm, whichever is greater. For peripheral discontinuities, the maximum depth may be 0.06 *D* (see Fig. 1).

10.2.1.2 Forging defects located in the socket wall within 0.1 times the actual key engagement, *T*, from the bottom of the socket are not permissible. Discontinuities located elsewhere in the socket shall not have a length exceeding 0.25 *T*, or a maximum depth of 0.03 *D* not to exceed 0.13 mm (see Fig. 2).

10.2.1.3 Seams in the shank shall not exceed a depth of 0.03 *D* or 0.2 mm, whichever is greater.

10.2.1.4 No transverse discontinuities shall be permitted in the head-to-shank fillet area.

10.2.1.5 Threads shall have no laps at the root or on the flanks, as shown in Fig. 3. Laps are permitted at the crests (Fig. 3(c)) that do not exceed 25 % of the basic thread depth, and on the flanks outside the pitch cylinder. Longitudinal seams rolled beneath the root of the thread and across the crests of the threads are acceptable within the limits of 10.2.1.3.

11. Number of Tests

11.1 The requirements of this specification shall be met in continuous mass production for stock and the manufacturer

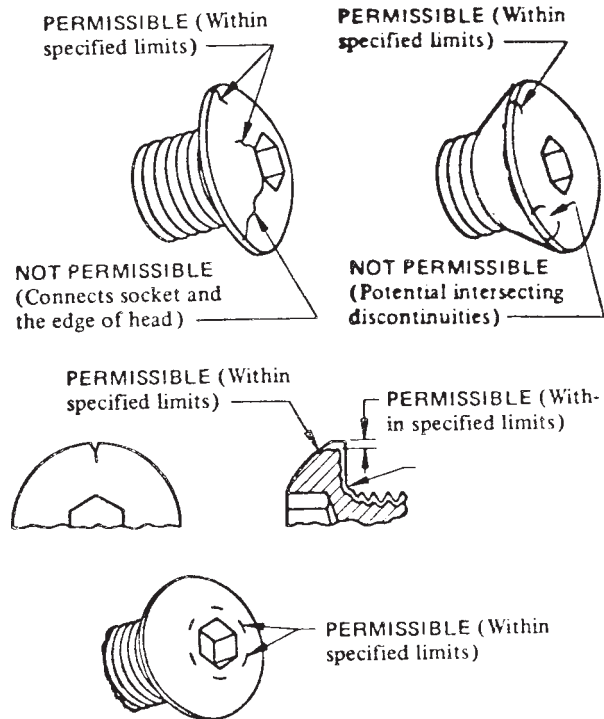

FIG. 1 Head Discontinuities (See 10.2.1)

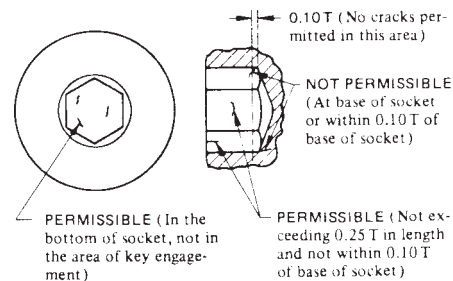

FIG. 2 Socket Discontinuities (See 10.2.1)

shall make sample inspection to ensure that the product conforms to the specified requirements. Additional tests of individual shipments of fasteners are not ordinarily necessary. A record of the individual heat of steel in each lot shall be maintained. The containers shall be coded to permit identification of the lot.

11.2 When specified in the purchase order, the manufacturer shall furnish a test report of the last complete set of chemical

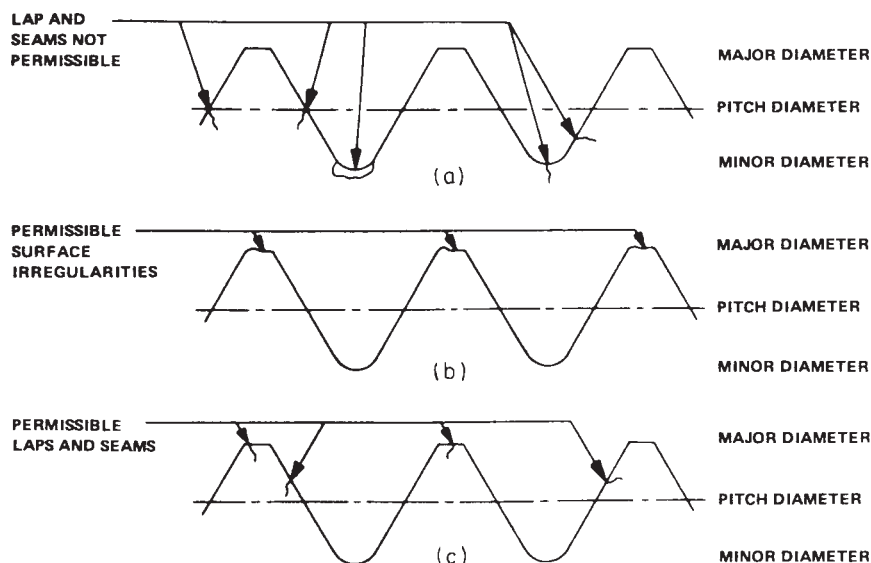

FIG. 3 Thread Discontinuities

analysis and mechanical tests for each stock size in each shipment.

11.3 When tests of individual shipments are required, Supplementary Requirement S1 must be specified in the inquiry and order.

11.3.1 When the purchaser does not specify the sampling plan and basis of acceptance, the following shall apply:

11.3.1.1 The lot, for purposes of selecting samples, shall consist of all products offered for inspection and testing at one time, that are of the same type, style, nominal diameter, thread pitch, nominal length, material, property class, and surface finish.

11.3.1.2 From each lot, samples shall be selected at random and tested for each requirement in accordance with the following:

Number of Pieces in Lot	Number of Samples
800 and less	1
Over 800 to 8000, incl	2
Over 8000 to 22 000, incl	3
Over 22 000	5

11.3.1.3 Should any sample fail to meet the requirements of a specified test, double the number of samples from the same lot shall be retested for the requirement(s) in which it failed. All of the additional samples shall conform to the specification or the lot shall be rejected.

11.3.1.4 If the failure of a test specimen is due to improper preparation of the specimen or an incorrect testing technique, the specimen shall be discarded and another test specimen submitted.

11.4 Corrosion Resistance Tests:

11.4.1 Unless otherwise specified, inspection for corrosion resistance shall be in accordance with the manufacturer's standard quality control practices. No specific method of inspection is required but the screws shall be produced from suitable raw material and manufactured by properly controlled practices to maintain resistance to corrosion. When corrosion tests are required, Supplementary Requirement S4 must be specified in the inquiry and order, except as noted in 11.4.2.

11.4.2 Products that have been hot worked shall be solution annealed and tested to determine freedom from precipitated carbides. Not less than one corrosion test shall be made from each lot. Corrosion tests shall be performed in accordance with Practices A 262, Practices A or E as applicable.

12. Test Methods

12.1 Chemical Analysis—The chemical composition shall be determined in accordance with Test Method A 751.

12.1.1 The fastener manufacturer may accept the chemical analysis of each heat of raw material purchased and reported on the raw material certification furnished by the raw material producer. The fastener manufacturer is not required to do any further chemical analysis testing provided that precise heat lot traceability has been maintained throughout the manufacturing process on each lot of fasteners produced and delivered.

12.2 Mechanical Tests:

12.2.1 Screws tested for axial strength, screw extension, or hardness shall be tested in accordance with the methods described in Test Methods F 606M and 12.2.3 of this specification. The hardness shall be determined using Test Methods E 18, E 92, or E 384 as appropriate. Fracture in the A1-55 or A1-70 class may occur at the head/shank juncture (see Note 1 of Table 3) due to the part design.

12.2.2 Machined test specimens tested for tensile strength, yield strength at 0.2 % offset, and elongation shall be tested in accordance with the methods described in Test Methods F 606M.

12.2.3 Extension Test—An extension test is applicable only to full-size products. The overall length of the test specimen,  $L_1$ , shall be measured within  $\pm 0.12$  mm. The head-end reference surface for length measurement may be the bottom of the hex socket for measuring purposes. The specimen shall be assembled into a threaded adapter to a depth of one nominal diameter, then axial tensile tested in accordance with 12.2.1 to failure. The two broken pieces shall be fitted closely together and the overall length,  $L_2$ , measured again. The total extension shall be computed by subtracting the original overall length

from the length following fracture (Fig. 4). The product is acceptable when the extension equals or exceeds the minimum value for extension specified in Table 1.

12.3 *Corrosion Resistance*—When specified on the purchase order or inquiry, corrosion tests to determine freedom from precipitated carbides shall be performed in accordance with Practices A 262, Practice A or E as applicable.

### 13. Inspection

13.1 If the inspection described in 13.2 is required by the purchaser, it shall be specified in the inquiry, order, or contract.

13.2 The inspector representing the purchaser shall have free entry to all parts of the manufacturer’s works that concern the manufacture of the material ordered. The manufacturer shall afford the inspector all reasonable facilities to satisfy that the material is being furnished in accordance with this specification. All tests and inspection required by the specification that are requested by the purchaser’s representative and purchase order shall be made prior to shipment, and shall be so conducted as not to interfere unnecessarily with the operation of the work.

### 14. Rejection and Rehearing

14.1 Screws that fail to conform to the requirements of this specification may be rejected by the purchaser. Rejection shall

be reported to the supplier promptly and in writing. In case of dissatisfaction with the results of tests or inspection authorized by the purchaser, the supplier may make claim for a rehearing.

### 15. Certification

15.1 *Test Report*—The manufacturer shall maintain on file for a period of 5 years, the original test report, including a copy of the certified chemical analysis of the heat of material used and the results of the required testing for the lot of fasteners.

15.2 *Manufacturer’s Certificate of Conformance*—The manufacturer shall maintain on file for a period of 5 years, a certificate indicating that the lot of fasteners was manufactured and tested in accordance with this specification and conforms to all specified requirements.

15.3 When requested by the purchaser, submission of copies of the test report, manufacturer’s certificate or an extension of the 5-year document retention period shall be performed as agreed between the manufacturer and the purchaser at the time of the inquiry or order.

### 16. Product Marking

16.1 For nominal sizes M5 (5 mm) and larger, the A1-50 fasteners shall be marked “A1-50” For nominal sizes M5 (5 mm) and larger, the A1-70 fasteners shall be marked “A1-70.” The A1-55 fasteners need not be marked with the property class designation. For all three property classes, the manufacturer’s identification insignia shall be placed on the side or top of the head and known and recognizable to the purchaser. The insignia shall be readable with no more than 10× magnification.

### 17. Packaging and Package Marking

17.1 *Packaging*:

17.1.1 Unless otherwise specified, packaging shall be in accordance with Practice D 3951.

17.1.2 When special packaging requirements are required by the purchaser, they shall be defined at the time of inquiry and order.

17.2 *Package Marking*—Each shipping unit shall include or be plainly marked with the following:

- 17.2.1 ASTM specification,
- 17.2.2 Property class symbol,
- 17.2.3 Alloy number,
- 17.2.4 Size,
- 17.2.5 Name and brand or trademark of the manufacturer,
- 17.2.6 Country of origin,
- 17.2.7 Number of pieces, and
- 17.2.8 Purchase order number.

### 18. Keywords

18.1 corrosion resistant; stainless steel; socket button head cap screws; socket flat countersunk head cap screws

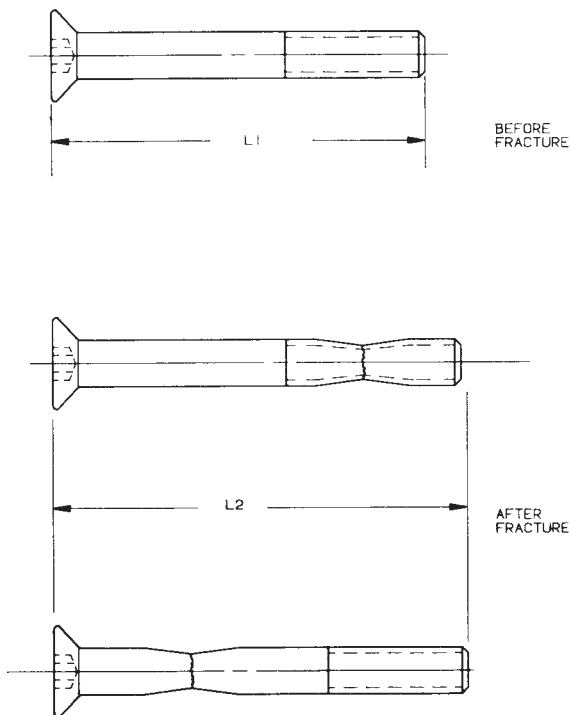

FIG. 4 Test Specimen-Extension Test



**SUPPLEMENTARY REQUIREMENTS**

One or more of the following supplementary requirements shall apply only when specified by the purchaser in the inquiry and order (see 4.1.6). Supplementary requirements shall in no way negate any requirement of the specification itself.

**S1. Shipment Lot Testing**

S1.1 When Supplementary Requirement S1 is specified on the order, the manufacturer shall make sample tests on the individual lots for shipment to ensure that the product conforms to the specified requirements.

S1.2 The manufacturer shall make an analysis of a randomly selected finished fastener from each lot of product to be shipped. Heat or lot control shall be maintained. The analysis of the starting material from which the fasteners have been manufactured may be reported in place of the product analysis.

S1.3 The manufacturer shall perform mechanical property tests in accordance with this specification and Guide F 1470 on the individual lots for shipment.

S1.4 The manufacturer shall furnish a test report for each lot in the shipment showing the actual results of the chemical analysis and mechanical property tests performed in accordance with Supplementary Requirements S1.

**S2. Alloy Control**

S2.1 When Supplementary Requirement S2 is specified on the inquiry and order, the manufacturer shall supply that stainless steel specified on the customer's order with no group

substitutions permitted without written permission by the purchaser.

**S3. Permeability**

S3.1 When Supplementary Requirement S3 is specified on the inquiry and order, the permeability of Property Class A1-50 screws shall not exceed 1.05 at 100 oersteds when determined by Test Method A 342. Screws in Property Classes A1-55 or A1-70 may not be capable of meeting permeability and strength requirements simultaneously. Consultation with the raw material manufacturer should be considered for critical permeability requirements.

**S4. Corrosion Resistance Tests**

S4.1 When Supplementary Requirement S4 is specified on the inquiry and order, corrosion test(s) shall be performed as agreed between the manufacturer and the purchaser at the time of the inquiry or order.

**S5. Passivation**

S5.1 When Supplementary Requirement S5 is specified on the inquiry and order, the finished product shall be passivated in accordance with Specification A 380.

*ASTM International takes no position respecting the validity of any patent rights asserted in connection with any item mentioned in this standard. Users of this standard are expressly advised that determination of the validity of any such patent rights, and the risk of infringement of such rights, are entirely their own responsibility.*

*This standard is subject to revision at any time by the responsible technical committee and must be reviewed every five years and if not revised, either reapproved or withdrawn. Your comments are invited either for revision of this standard or for additional standards and should be addressed to ASTM International Headquarters. Your comments will receive careful consideration at a meeting of the responsible technical committee, which you may attend. If you feel that your comments have not received a fair hearing you should make your views known to the ASTM Committee on Standards, at the address shown below.*

*This standard is copyrighted by ASTM International, 100 Barr Harbor Drive, PO Box C700, West Conshohocken, PA 19428-2959, United States. Individual reprints (single or multiple copies) of this standard may be obtained by contacting ASTM at the above address or at 610-832-9585 (phone), 610-832-9555 (fax), or service@astm.org (e-mail); or through the ASTM website (www.astm.org).*