



Standard Specification for Alloy Steel Socket Set Screws¹

This standard is issued under the fixed designation F 912; the number immediately following the designation indicates the year of original adoption or, in the case of revision, the year of last revision. A number in parentheses indicates the year of last reappraisal. A superscript epsilon (ϵ) indicates an editorial change since the last revision or reappraisal.

This standard has been approved for use by agencies of the Department of Defense.

1. Scope *

1.1 This specification covers the requirements for quenched and tempered alloy steel socket-set screws (SSS) 0.060 through 2.000-in. sizes having hardnesses 45 to 53 HRC.

1.2 These set screws are intended for compression applications only and are not customarily subjected to embrittlement tests. For tensile applications, consult with the manufacturer for proper alloy and hardness.

1.3 The hazard statement pertains only to the test method section, Section 11 of this specification. *This standard does not purport to address all of the safety concerns, if any, associated with its use. It is the responsibility of the user of this standard to establish appropriate safety and health practices and determine the applicability of regulatory limitations prior to use.*

NOTE 1—A complete metric companion to Specification F 912 has been developed—F 912M; therefore, no metric equivalents are shown in this Specification.

2. Referenced Documents

2.1 ASTM Standards:

A 751 Test Methods, Practices, and Terminology for Chemical Analysis of Steel Products²

D 3951 Practice for Commercial Packaging³

E 3 Methods of Preparation of Metallographic Specimens⁴

E 18 Test Methods for Rockwell Hardness and Rockwell Superficial Hardness of Metallic Materials⁴

E 112 Test Methods for Determining Average Grain Size⁴

E 384 Test Method for Microhardness of Materials⁴

F 788/F788M Specification for Surface Discontinuities of Bolts, Screws, and Studs, Inch and Metric Series⁵

2.2 ANSI/ASME Standards:

B18.3 Socket Cap, Shoulder and Set Screw, Inch Series⁶

¹ This specification is under the jurisdiction of ASTM Committee F16 on Fasteners and is the direct responsibility of Subcommittee F16.02 on Steel Bolts, Nuts, Rivets, and Washers.

Current edition approved May 10, 2000. Published July 2000. Originally published as F 912 – 86. Last previous edition F 912 – 99.

² Annual Book of ASTM Standards, Vol 01.03.

³ Annual Book of ASTM Standards, Vol 15.09.

⁴ Annual Book of ASTM Standards, Vol 03.01.

⁵ Annual Book of ASTM Standards, Vol 01.08.

⁶ Available from American National Standards Institute, 11 West 42nd St., 13th Floor, New York, NY 10036.

B18.24.1 Part Identifying Number (PIN) Code System⁷

3. Ordering Information

3.1 Orders for material under this specification shall include the following information:

3.1.1 Quantity (number of screws).

3.1.2 Dimensions, including nominal thread designation, threads per inch, nominal screw length (inches) and point configuration. A standard part number may be used for this definition.

3.1.3 Name of the screw (SSS).

3.1.4 Coating, if required. See 4.4.

3.1.5 Lot testing, if required. See 10.3.

3.1.6 Certification, if required. See 14.1.

3.1.7 ASTM designation and year of issue.

3.1.8 Any special or supplemental requirements.

3.1.9 For establishment of a part identifying system, see ASME B18.24.1.

4. Materials and Manufacture

4.1 The screws shall be fabricated from alloy steel made to fine grain practice. In the event of controversy over grain size, referee tests on finished screws conducted in accordance with Test Methods E 112 shall prevail.

4.2 The screws may be forged, formed, extruded, machined, or ground to meet the dimensional characteristics and performance requirements.

4.3 Set screws shall be heat treated by quenching in oil from above the transformation temperature and then tempered by reheating to meet the hardness range specified in 6.2.

4.4 *Standard Finishes*—Unless otherwise specified, the screws shall be furnished with one of the following standard surfaces as manufactured, at the option of the manufacturer; (1) bright uncoated; (2) thermal black oxide; or (3) chemical black oxide. Hydrogen embrittlement tests shall not be required for screws furnished in these conditions.

4.5 Protective Coatings:

4.5.1 When a protective finish other than as specified in 4.4 is required, it shall be specified on the purchase order with the applicable finish specification.

4.5.2 When protective or decorative coatings are applied to

⁷ Available from American Society of Mechanical Engineers, Three Park Avenue, New York, NY 10016–5990.

*A Summary of Changes section appears at the end of this standard.

the screws, precautions specified by the coating requirements to minimize embrittlement shall be exercised.

5. Chemical Composition

5.1 The chemical composition of the screw material shall conform to the heat analysis specified in Table 1.

5.2 One or more of the following alloying elements: chromium, nickel, molybdenum, or vanadium shall be present in the steel in sufficient quantity to assure the specific strength properties are met after oil quenching and tempering. The steel shall meet the AISI definition of alloy steel, that is, maximum and minimum element content requirement or minimum element limits specified.

5.3 Alloy steel to which bismuth, selenium, tellurium, or lead has been intentionally added to improve machinability shall be permitted.

5.4 Material analysis may be made by the purchaser from finished products and the chemical composition thus determined shall conform to the requirements specified for the product analysis in Table 1.

6. Mechanical Properties

6.1 Socket set screws when subjected to a torque test in accordance with 11.2 shall withstand application of the test tightening torque specified in Table 2 without evidence of the socket reaming or the screw bursting.

6.2 Socket set screws shall have a hardness of 45 to 53 HRC. The hardness limits shall apply throughout the screw from core to surface.

7. Other Requirements

7.1 Decarburization:

7.1.1 There shall be no evidence of gross decarburization of the surfaces of the heat-treated screws when measured in accordance with 11.4.

7.1.2 The depth of partial decarburization shall be limited to the values in Table 3 when measured as shown in Fig. 1, and in accordance with 11.4.

8. Dimensions

8.1 Unless otherwise specified, the product shall conform to the requirements of ANSI/ASME B 18.3.

9. Workmanship, Finish, and Appearance

9.1 Surface Discontinuities:

9.1.1 The surface discontinuities for these products shall conform to Specification F 788/F 788M and the additional limitations specified herein.

9.1.2 Processing defects that connect the socket to the periphery of the screw are not permissible. Defects originating on the periphery and with a traverse indicating a potential to intersect are not permissible.

9.1.3 Quench cracks of any depth, any length, or in any location are not permitted.

10. Number of Tests

10.1 The requirements of this specification shall be met in continuous mass production for stock, and the manufacturer shall make ample inspections to insure that the product conforms to the specified requirements. Additional tests of individual shipments of material are not ordinarily contemplated. A record of individual heats of steel in each test lot shall be maintained. The container shall be coded to permit identification of the lot.

10.2 When specified in the order, the manufacturer shall furnish a test report certified to be the last complete set of mechanical tests for each stock size in each shipment.

10.3 When additional tests are specified on the purchase order, a lot, for purposes of selecting test samples, shall consist of all screws offered for inspection at one time of one diameter and length. From each lot, the number of samples for each requirement shall be as follows: (Note: This will be aligned with F 16.02 assurance decision.)

Number of Pieces in Lot	Number of Samples
800 and less	1
Over 800 to 8000, incl	2
Over 8000 to 22 000, incl	3
Over 22 000	5

10.4 Should any sample fail to meet the requirements of a specified test, double the number of samples from the same lot shall be retested for the requirement(s) in which it failed. All of the additional samples shall conform to the specification or the lot shall be rejected.

11. Test Methods

11.1 Chemical analysis shall be conducted in accordance with Test Methods A 751.

11.2 For socket strength torque test, the test screw shall be assembled into a tapped hole of 2B tolerance class in a steel block (see Fig. 2) until the face of the screw is flush with the top surface of the test block and the set screw bears against a firm base, such as a hardened screw installed from the opposite side of the block. The applicable hexagon key bit in accordance with ANSI/ASME B 18.3 shall be inserted to the full depth of the set screw socket and the test torque listed in Table 2 applied by means of a torque wrench. The screw shall be disassembled from the block and examined for compliance to the requirements of 6.1.

11.3 Hardness shall be determined in accordance with Test Methods E 18.

11.4 Decarburization and carburization tests shall be conducted as follows:

11.4.1 Section the thread area of the screw longitudinally through the axis, mount, and polish it in accordance with Methods E 3. Use one of the two methods for carburization or decarburization evaluation: either optical or microhardness

TABLE 1 Chemical Requirements

NOTE 1—Plus alloys in accordance with 5.2.

Element	Composition, %	
	Heat Analysis	Product Analysis
Carbon	0.30 to 0.48	0.28 to 0.50
Phosphorus, max	0.035	0.040
Sulfur, max	0.040	0.045

TABLE 2 Torsional Strength Requirements

Nominal Size	Shortest Nominal Screw Lengths Subject to Torque Testing for			Test Torque
	Cup and Flat Points	Cone and Oval Points	Half Dog Points	in.-lb, min
0	0.060	0.109	0.125	1.1
1	0.073	0.125	0.141	2.1
2	0.086	0.125	0.141	2.1
3	0.099	0.141	0.156	6.0
4	0.112	0.141	0.172	6.0
5	0.125	0.156	0.188	11
6	0.138	0.172	0.203	11
8	0.164	0.188	0.219	23
10	0.190	0.188	0.250	40
1/4	0.250	0.250	0.312	94
5/16	0.312	0.312	0.391	183
3/8	0.375	0.375	0.438	317
7/16	0.437	0.438	0.484	502
1/2	0.500	0.500	0.547	750
5/8	0.625	0.625	0.766	1460
3/4	0.750	0.750	0.906	2520
7/8	0.875	0.875	1.125	5750
1	1.000	1.000	1.266	8000
1 1/8	1.125	1.125	1.391	8000
1 1/4	1.250	1.250	1.500	11 000
1 3/8	1.375	1.375	1.656	11 000
1 1/2	1.500	1.500	1.797	18 100
1 3/4	1.750	1.750	2.219	38 000
2	2.000	2.000	2.391	38 000

TABLE 3 Decarburization Limits

Threads/in.	Thread Height, h_s	0.75 h_s from Root to Crest, min	0.1 h_s at Root, max
48	0.013	0.010	0.001
44	0.014	0.011	0.001
40	0.015	0.011	0.002
36	0.017	0.013	0.002
32	0.019	0.014	0.002
28	0.022	0.017	0.002
24	0.026	0.020	0.003
20	0.031	0.023	0.003
18	0.034	0.026	0.003
16	0.038	0.029	0.004
14	0.044	0.033	0.004
13	0.047	0.035	0.005
12	0.051	0.038	0.005
11	0.056	0.042	0.006
10	0.061	0.046	0.006
9	0.068	0.051	0.007
8	0.077	0.058	0.008
7	0.088	0.066	0.009
6	0.102	0.077	0.010
5	0.123	0.092	0.012
4.5	0.136	0.102	0.014
4	0.153	0.115	0.015

11.4.3 Measure microhardness in accordance with Test Method E 384 on unetched specimens using a DPH 136° indenter or a Knoop indenter using the following load application:

Number of Threads per inch	Load
Less than 40	500 gf
40, 44, and 48	200 gf
Over 48	Use optical evaluation in 11.4.2

11.4.3.1 Screw threads greater than 48 threads per inch, optical evaluation as described in 11.4.2 shall determine conformance to specification requirements. Take measurements at the minor diameter (Reading No. 1) on the thread crest bisector to determine base material hardness. Take measurements (Reading No. 2) on the bisector 0.75 h_s from the minor measurement toward the thread crest. Also take measurements (Reading No. 3) on the thread flank at the pitch line at a depth within 0.003 in. from the surface. Reading No. 3 may be taken on the same or an adjacent thread.

11.4.4 Interpret Microhardness Readings as Follows:

11.4.4.1 A decrease of more than 30 hardness points from Reading No. 1 to Reading No. 2 shall be regarded as decarburization and indicates the screw does not conform to specification requirements.

11.4.4.2 An increase of more than 30 hardness points from Reading No. 1 to Reading No. 3 shall be regarded as carburization and indicates that the screw does not conform to specification requirements.

12. Inspection

12.1 The inspector representing the purchaser, upon reasonable notice, shall have free entry to all parts of the manufacturer's works that concern the manufacture of the material

measurements. The microhardness measurement shall constitute a referee method in case of dispute.

11.4.2 For optical measurement, etch the section in 2– 4 % nital. Examine the surface of the etched samples under a microscope at 100× using a measuring eyepiece graduated in 0.001-in. increments. The width of any light etching band normally defines the decarburization depth. A dark etching band indicates the possibility of carburization.

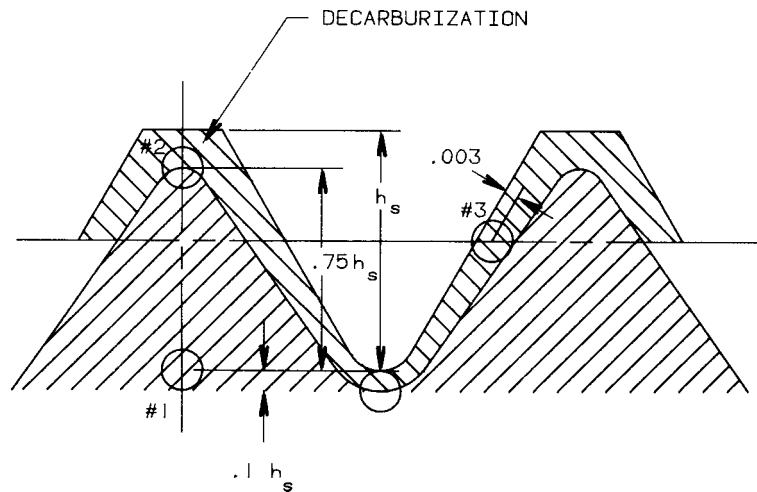

FIG. 1 Definition of Partial Decarburization Limits

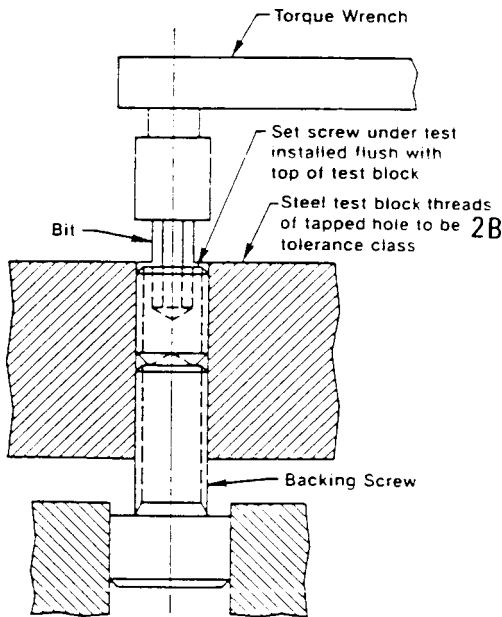

FIG. 2 Typical Torque Test Fixture

dissatisfaction with the results of the test, the producer or supplier may make claim for a rehearing.

14. Certification

14.1 Upon request of the purchaser in the contract or order, a manufacturer's certification that the material was manufactured and tested in accordance with this specification, together with a report of the latest mechanical tests of each stock size in each shipment, shall be furnished at the time of shipment.

15. Responsibility

15.1 The party responsible for the fastener shall be the organization that supplies the fastener to the purchaser and certifies that the fastener was manufactured, sampled, tested and inspected in accordance with this specification and meets all of its requirements.

16. Packaging and Package Marking

16.1 Packaging:

16.1.1 Unless otherwise specified, packaging shall be in accordance with Practice D 3951.

16.1.2 When special packaging requirements are required, they shall be defined at the time of the inquiry and order.

16.2 Package Marking:

16.2.1 Each shipping unit shall include or be plainly marked with the following information:

- 16.2.1.1 ASTM designation,
- 16.2.1.2 Size,
- 16.2.1.3 Name and brand or trademark of the manufacturer,
- 16.2.1.4 Number of pieces,
- 16.2.1.5 Purchase order number, and
- 16.2.1.6 Country of origin.

17. Keywords

- 17.1 alloy; set; socket; steel

ordered. The manufacturer shall afford the inspector all reasonable facilities to satisfy him that the material is being furnished in accordance with this specification. All tests and inspections required by the specification that are requested by the purchaser's representative shall be made before shipment, and shall be so conducted as not to interfere unnecessarily with the operation of the works.

13. Rejection and Rehearing

13.1 Material that fails to conform to the requirements of this specification may be rejected. Rejection should be reported to the producer or supplier promptly and in writing. In case of

SUMMARY OF CHANGES

This section identifies the location of selected changes to this standard that have been incorporated since the –99 issue. For the convenience of the user, Committee F16 has highlighted those changes that impact the use of this standard. This section may also include descriptions of the changes or reasons for the changes, or both.

- (1) Added 3.1.9, providing for optional use of ASME B18.24.1, Part Identifying Number (PIN) Code System.

The American Society for Testing and Materials takes no position respecting the validity of any patent rights asserted in connection with any item mentioned in this standard. Users of this standard are expressly advised that determination of the validity of any such patent rights, and the risk of infringement of such rights, are entirely their own responsibility.

This standard is subject to revision at any time by the responsible technical committee and must be reviewed every five years and if not revised, either reapproved or withdrawn. Your comments are invited either for revision of this standard or for additional standards and should be addressed to ASTM Headquarters. Your comments will receive careful consideration at a meeting of the responsible technical committee, which you may attend. If you feel that your comments have not received a fair hearing you should make your views known to the ASTM Committee on Standards, at the address shown below.

This standard is copyrighted by ASTM, 100 Barr Harbor Drive, PO Box C700, West Conshohocken, PA 19428-2959, United States. Individual reprints (single or multiple copies) of this standard may be obtained by contacting ASTM at the above address or at 610-832-9585 (phone), 610-832-9555 (fax), or service@astm.org (e-mail); or through the ASTM website (www.astm.org).