



Standard Specification for Cartridge Brass Cartridge Case Cups¹

This standard is issued under the fixed designation B 129; the number immediately following the designation indicates the year of original adoption or, in the case of revision, the year of last revision. A number in parentheses indicates the year of last reapproval. A superscript epsilon (ϵ) indicates an editorial change since the last revision or reapproval.

1. Scope *

1.1 This specification establishes the requirements for annealed cartridge brass cups produced of Copper Alloy UNS No. C26000 for processing into cartridge cases of the following types:

- 1.1.1 *Type I*, for small arms cartridge case cups, and
- 1.1.2 *Type II*, for artillery cartridge case cups.

1.2 The values stated in inch-pound units are the standard, except for grain size, which is given in SI units. Values in parentheses are for information only.

2. Referenced Documents

2.1 ASTM Standards:

- B 601 Classification for Temper Designations for Copper and Copper Alloys—Wrought and Cast²
- B 846 Terminology for Copper and Copper Alloys²
- E 3 Guide for Preparation of Metallographic Specimens³
- E 29 Practice for Using Significant Digits in Test Data to Determine Conformance with Specifications⁴
- E 112 Test Methods for Determining Average Grain Size³
- E 255 Practice for Sampling Copper and Copper Alloys for Determination of Chemical Composition⁵
- E 478 Test Methods for Chemical Analysis of Copper Alloys⁵

3. Terminology

3.1 For definitions of terms related to copper and copper alloys, refer to Terminology B 846.

3.2 Definitions of Terms Specific to This Standard:

3.2.1 *blank (blanking), n*—a piece of metal removed from sheet or strip, intended for subsequent fabrication such as cupping and drawing.

3.2.2 *cup (cupping), n*—a shallow cylindrical shell closed at one end, normally intended for further fabrication, formed from a blank.

4. Ordering Information

4.1 Orders of product under this specification should include the following information:

- 4.1.1 ASTM designation and year of issue,
- 4.1.2 Type (Section 1),
- 4.1.3 Grain size (Section 7),
- 4.1.4 Dimensions and tolerances (see 8.1),
- 4.1.5 Drawing number to which order applies (see 8.1), and
- 4.1.6 When the material is purchased for agencies of the U.S. Government, (see Supplementary Requirements section).

5. Material and Manufacture

5.1 Material:

5.1.1 The material of manufacture shall be annealed plate, sheet, strip, or disks of wrought Alloy UNS No. C26000 processed to produce even-topped cups.

5.2 Manufacture:

5.2.1 The material shall be blanked and cupped to meet the cup dimensions specified, and subsequently annealed. The annealed cups shall be pickled, washed, and dried.

6. Chemical Composition

6.1 The product shall conform to the requirements prescribed in Table 1.

6.2 Composition limits may be established and analysis required for unnamed elements by agreement between manufacturer and purchaser.

6.3 Either copper or zinc may be taken as the difference between the sum of all elements analyzed and 100 %. Copper, when determined by the difference, must conform to the requirements of Table 1. When all elements in Table 1 are analyzed, their sum shall be 99.7 % min.

7. Grain Size of Annealed Tempers

7.1 Unless there is a prior agreement between the purchaser and supplier, the grain size for 0.30, 0.45, and 0.50 calibers will be produced to the grain size requirements specified in Table 2.

7.1.1 Grain size ranges other than those specified in Table 2 shall be established by agreement between manufacturer and purchaser.

¹ This specification is under the jurisdiction of ASTM Committee B05 on Copper and Copper Alloys and is the direct responsibility of Subcommittee B05.01 on Plate, Sheet, and Strip.

Current edition approved April 10, 2002. Published June 2002. Originally published as B 129 – 40 T. Last previous edition B 129 – 96.

² *Annual Book of ASTM Standards*, Vol 02.01.

³ *Annual Book of ASTM Standards*, Vol 03.01.

⁴ *Annual Book of ASTM Standards*, Vol 14.02.

⁵ *Annual Book of ASTM Standards*, Vol 03.05.

*A Summary of Changes section appears at the end of this standard.

TABLE 1 Chemical Requirements

Copper Alloy UNS No. C26000	
Element	Composition, %
Copper	68.5–71.5
Lead, max	0.07
Iron, max	0.05
Bismuth, max	0.006
Zinc	remainder

TABLE 2 Grain Size Requirements on Sidewall^A

Type	Caliber	Temper Designation ^B	Diameter of Average Grain Size, mm	
			min	max
I	0.30 and 0.45	OS080	0.045	0.120
	0.50	OS110	0.065	0.150
II	Grain size subject to agreement by the manufacturer and the purchaser			

^A Approximately midway of the length of the sidewall.

^B Standard designations are defined in Practice B 601.

7.1.2 Grain size ranges for other cups shall be established by agreement between manufacturer and purchaser.

8. Dimensions, Mass, and Permissible Variations

8.1 All dimensions and tolerances of cups shall be as indicated on the drawings furnished with the purchase order or contract.

9. Workmanship, Finish, and Appearance

9.1 The cups shall be uniform in quality and shall be free of oil, grease, oxidation, stains, scale, chips, acid, dirt or grit, dented or bent edges, laminations, slivers, laps, cracks, deep scratches, wrinkles, or other injurious defects which would interfere with the purpose for which the cups are intended. The cups, subsequent to annealing, shall be pickled, washed, and dried.

10. Sampling

10.1 The lot size, portion size, and selection of pieces shall be as follows:

10.1.1 *Lot Size*—40 000 lb (18 144 kg) or fraction thereof.

10.1.2 *Portion Size*:

10.1.2.1 For grain size—15 cups for Type I, or 2 cups for Type II.

10.1.2.2 For determination of dimensions—200 cups.

10.1.2.3 For the visual inspection—2000 cups.

10.1.3 Samples for chemical analysis are to be taken in accordance with Practice E 255.

11. Number of Tests and Retests

11.1 Specimens taken from each sample piece selected in accordance with 10.1.2.1 shall be tested for conformance to the grain size requirement.

11.2 *Retests*:

11.2.1 If the chemical analysis fails to conform to the specified limits, analysis shall be made on a composite sample, prepared from the pieces selected from each portion involved, consisting of either 15 cups from Type I or two cups from Type II. The results of this retest shall comply with the specified requirements.

11.2.2 Failure of more than two samples of Type I cups to comply to the grain size requirements shall be cause for rejection of the lot. If two samples fail to comply a retest shall be permitted on a sample double that of the original sample. Each of the specimens so retested shall meet the specified requirements.

11.2.3 Failure of the two samples of Type II cups to comply to the grain size requirements shall be cause for rejection of the lot. If one sample fails, a retest shall be permitted on a sample double that of the original sample. Each of the specimens so retested shall meet the specified requirements.

12. Specimen Preparation

12.1 For grain size measurements, either tangential grinding and polishing, or cutting, mounting, and polishing methods may be used to reach the zone (Fig. 1).

12.1.1 The test specimen shall be prepared in accordance with Practice E 3.

12.2 Specimens for chemical analysis shall be prepared in accordance with Practice E 255.

13. Test Methods

13.1 The properties and chemical compositions enumerated in this specification shall, in case of disagreement, be determined in accordance with the following ASTM methods:

Test	ASTM Designation
Chemical analysis	E 478
Grain size	E 3, E112

13.2 The test method(s) used for determination of element(s) required by contractual or purchase order agreement shall be as agreed upon between the manufacturer and the purchaser.

13.3 Grain size measurements shall be made in a zone which is the approximate midpoint of the side wall length and thickness of the cups, as shown in Fig. 1. At least three measurements shall be made, averaged, and recorded for each grain size determination.

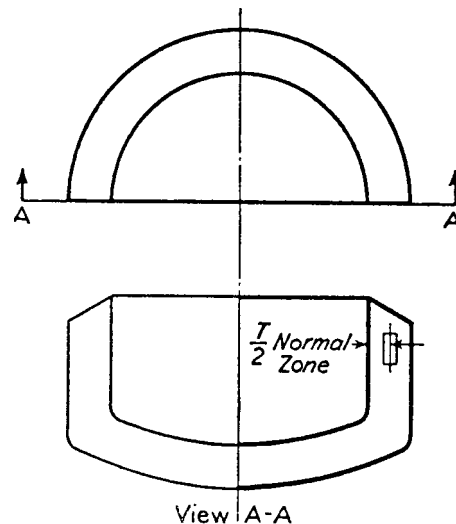

FIG. 1 Location of Areas to be Examined for Grain Size in Cartridge Case Cups

13.4 When specified on the purchase order or contract, grain size measurements shall also be made on the base of the same cups as 13.3. These measurements shall be made in a zone approximately bounding the midpoint of the base, and approximately the midpoint of the thickness as shown in Fig. 1. At least three measurements shall be made, averaged, and recorded for each grain size determination.

14. Significance of Numerical Limits

14.1 For purposes of determining compliance with the specified limits for requirements of the properties listed in the following table, an observed value or a calculated value shall be rounded as indicated in accordance with the rounding method of Practice E 29.

Property	Rounded Unit for Observed or Calculated Value
Chemical composition	nearest unit in the last righthand significant digit used in expressing the limiting value
Grain size:	
Up to 0.055 mm, incl	nearest multiple of 0.005 mm
Over 0.055 to 0.160 mm, incl	nearest 0.01 mm

15. Inspection

15.1 *Visual Inspection*—Each cup in the sample shall be visually inspected.

15.1.1 *Major Defects*—Not more than 0.25 % of the cups in the sample shall contain the following major defects—scaly metal, deep scratches, laminations, slivers, laps, cracks, and wrinkles.

15.1.2 *Minor Defects*—Not more than 2 % of the cups in the sample shall contain the following minor defects—oily cup, greasy cup, dirty or gritty cup, oxidized cup, stained cup, dented or bent edges, and scratches.

15.2 *Measurement of Dimensions*—Each sample cup shall be gaged for compliance with all the dimensions shown on the applicable drawing. In addition, each cup in the sample shall be measured for side wall thickness at two or more opposite points on the same periphery. The variation in wall thickness of any cup so measured shall be within the limits as shown on the drawing.

NOTE 1—For the purpose of determining conformance with the dimensional requirements prescribed in this specification, any measured value outside the specified limiting values for any dimension may be cause for rejection.

15.3 If, in addition, source inspection of the material by the purchaser is agreed upon between the manufacturer and the purchaser as part of the purchase order or contract, the nature of the facilities needed to satisfy the inspector representing the purchaser that the product is being furnished in accordance with this specification shall be included in the agreement. All tests and the inspection shall be conducted so as not to interfere unnecessarily with the operation of the works.

15.4 The manufacturer and the purchaser, by mutual agreement, may accomplish the final inspection simultaneously.

NOTE 2—A deep scratch is one 0.005 in. (0.13 mm) or greater in depth.

16. Rejection and Rehearing

16.1 *Rejection*:

16.1.1 Product that fails to conform to specification requirements when inspected or tested by the purchaser or his agent may be rejected.

16.1.2 Rejection shall be reported to the manufacturer or supplier promptly and in writing.

16.1.3 In case of dissatisfaction with the results of the test upon which rejection is based, the manufacturer or supplier may make a claim for a rehearing.

16.2 *Rehearing*:

16.2.1 As a result of product rejection, the manufacturer or supplier may make claim for a retest to be conducted by the manufacturer or supplier and the purchaser.

16.2.2 Samples of the rejected product shall be taken in accordance with the product specification and tested by both parties following the test method(s) specified in the product specification, or, alternatively, upon agreement of both parties, an independent laboratory may be selected for the test(s) following the specified test methods.

17. Certification

17.1 When specified in the contract or purchase order, the purchaser shall be furnished certification that samples representing each lot have been either tested or inspected as directed in this specification and the requirements have been met.

18. Packaging and Package Marking

18.1 The product shall be separated by type and size, and prepared for shipment in such a manner as to ensure acceptance by common carrier for transportation and to afford protection from the normal hazards of transportation.

18.2 Each shipping unit shall be legibly marked with the purchase order number, type, size, gross and net weight, and name of supplier. The specification number shall be shown, when specified.

18.3 In addition to the above, specific instructions appearing on the purchase order or contract, or issued by the contracting officer, shall be adhered to, unless by mutual agreement, other provisions are established.

19. Test Report

19.1 When specified in the contract or purchase order, a report of test results shall be furnished.

20. Keywords

20.1 cartridge brass annealed cups; cartridge case cups

SUPPLEMENTARY REQUIREMENTS

The following supplementary requirements shall apply only when specified by the purchaser in the inquiry, contract or order, for agencies of the U.S. Government.

S1. Scope

S1.1 The following supplementary requirements shall apply only when specified by the purchaser in the inquiry, contract, or order, for agencies of the U.S. Government.

S2. Referenced Documents

S2.1 The following documents of the issue in effect on date of material purchase form a part of this specification to the extent referenced herein:

S2.1.1 Federal Standards:⁶

Fed. Std. No. 102 Preservation, Packaging and Packing Levels

Fed. Std. No. 123 Marking for Shipment (Civil Agencies)

Fed. Std. No. 185 Identification Marking of Copper and Copper-Base Alloy Mill Products

S2.1.2 Military Standards:⁶

MIL-STD-129 Marking for Shipment and Storage

S2.1.3 ASTM Standards:

B 900 Practice for Packaging of Copper and Copper-Alloy Mill-Products for U.S. Government Agencies²

S3. Quality Assurance

S3.1 *Responsibility for Inspection*—Unless otherwise specified in the contract or purchase order, the manufacturer is responsible for the performance of all inspection and test requirements specified. Except as otherwise specified in the contract or purchase order, the manufacturer may use his own or any other suitable facilities for the performance of the inspection and test requirements unless disapproved by the purchaser at the time the order is placed. The purchaser shall have the right to perform any of the inspections and tests set forth when such inspections and tests are deemed necessary to assure that the material conforms to prescribed requirements.

S4. Temper

S4.1 Type I cups except the caliber 0.50 (three draw), 20 mm and 30 mm cup, shall conform to a grain size requirement of 0.060 to 0.120 mm in the mid-sidewall and the grain size shall not exceed 0.150 mm in the base. The grain size for the caliber 0.50 (three draw), 20 mm and 30 mm cup shall be within 0.070 to 0.140 mm in the mid-sidewall and shall not exceed 0.170 mm in the base. The grain size of Type II cups

shall be as agreed upon between the manufacturer and the contracting officer.

S5. Initial Production Sample

S5.1 An initial production sample is required unless otherwise directed by the contracting officer.

S5.2 At the beginning of regular production, the supplier shall submit an initial production sample to a Government-approved facility for evaluation. The sample shall consist of 5200 cups. The sample shall be manufactured in the same manner, using the same materials, equipment, processes and procedures as used in regular production. All parts and materials must be the same as used in regular production and shall be obtained from the same source of supply. After inspection and provisional acceptance at source, 200 cups of the initial production sample shall be inspected at the Government approved facility for all requirements of the drawings and specifications, and the remaining 5000 cups shall be used for performance of the work test. The test shall comprise of all the operations in the manufacture of the appropriate cartridge case. The Government reserves the right to require new initial production samples until such time as an acceptable sample is submitted.

S6. Identification Marking

S6.1 All material shall be properly marked for identification in accordance with Fed. Std. No. 185 except that the ASTM specification number and the alloy number shall be used.

S7. Preparation for Delivery**S7.1 Preservation, Packaging, Packing:**

S7.1.1 *Military Agencies*—The material shall be separated by size, composition, grade or class and shall be preserved and packaged, Level A or C, packed Level A, B, or C as specified in the contract or purchase order, in accordance with the requirements of Practice B 900..

S7.1.2 *Civil Agencies*—The requirements of Fed. Std. No. 102 shall be referenced for definitions of the various levels of packaging protection.

S7.2 Marking:

S7.2.1 *Military Agencies*—In addition to any special marking required by the contract or purchase order, marking for shipment shall be in accordance with MIL-STD-120.

S7.2.2 *Civil Agencies*—In addition to any special marking required by the contract or purchase order, marking for shipment shall be in accordance with Fed. Std. No. 123.

⁶ Available from Standardization Documents Order Desk, Bldg. 4 Section D, 700 Robbins Ave., Philadelphia, PA 19111-5094, Attn: NPODS.

SUMMARY OF CHANGES

Committee B05 has identified the location of selected changes to this standard since the last issue (B 129 – 96) that may impact the use of this standard.

(1) Revised Terminology section.

(3) Added Bismuth properties to Table 1.

(2) Revised Chemical Composition section.

ASTM International takes no position respecting the validity of any patent rights asserted in connection with any item mentioned in this standard. Users of this standard are expressly advised that determination of the validity of any such patent rights, and the risk of infringement of such rights, are entirely their own responsibility.

This standard is subject to revision at any time by the responsible technical committee and must be reviewed every five years and if not revised, either reapproved or withdrawn. Your comments are invited either for revision of this standard or for additional standards and should be addressed to ASTM International Headquarters. Your comments will receive careful consideration at a meeting of the responsible technical committee, which you may attend. If you feel that your comments have not received a fair hearing you should make your views known to the ASTM Committee on Standards, at the address shown below.

This standard is copyrighted by ASTM International, 100 Barr Harbor Drive, PO Box C700, West Conshohocken, PA 19428-2959, United States. Individual reprints (single or multiple copies) of this standard may be obtained by contacting ASTM at the above address or at 610-832-9585 (phone), 610-832-9555 (fax), or service@astm.org (e-mail); or through the ASTM website (www.astm.org).