



Standard Specification for Copper Alloy Bullet Jacket Cups¹

This standard is issued under the fixed designation B 131; the number immediately following the designation indicates the year of original adoption or, in the case of revision, the year of last revision. A number in parentheses indicates the year of last reapproval. A superscript epsilon (ϵ) indicates an editorial change since the last revision or reapproval.

1. Scope *

1.1 This specification establishes the requirements for bullet jacket preform cups produced of Copper Alloy UNS No. C22000 for processing into bullet jackets of the following types and classes:

- 1.1.1 *Type I*—Caliber 0.30.
- 1.1.2 *Type II*—Caliber 0.45.
- 1.1.3 *Type III*—Caliber 0.50.
- 1.1.4 *Type IV*—As specified in the contract or order.
- 1.1.5 *Class I*—Not annealed.
- 1.1.6 *Class II*—Annealed.

1.2 The values stated in inch-pound units are the standard, except for grain size, which is given in SI units. Values in parentheses are for information only.

2. Referenced Documents

2.1 ASTM Standards:

- B 601 Practice for Temper Designations for Copper and Copper Alloys—Wrought and Cast²
- E 3 Practice for Preparation of Metallographic Specimens³
- E 29 Practice for Using Significant Digits in Test Data to Determine Conformance with Specifications⁴
- E 112 Test Methods for Determining Average Grain Size³
- E 255 Practice for Sampling Copper and Copper Alloys for Determination of Chemical Composition⁵
- E 478 Test Methods for Chemical Analysis of Copper Alloys⁵

3. Terminology

3.1 Definitions:

3.1.1 *blank (blanking), n*—a piece of metal removed from sheet or strip, intended for subsequent fabrication such as cupping and drawing.

3.1.2 *cup (cupping), n*—a shallow cylindrical shell closed at one end, normally intended for further fabrication, formed from a blank.

¹ This specification is under the jurisdiction of ASTM Committee B-5 on Copper and Copper Alloys and is the direct responsibility of Subcommittee B05.01 on Plate, Sheet and Strips.

Current edition approved April 10, 1996. Published June 1996. Originally published as B 131 – 40 T. Last previous edition B 131 – 88.

² Annual Book of ASTM Standards, Vol 02.01.

³ Annual Book of ASTM Standards, Vol 03.01.

⁴ Annual Book of ASTM Standards, Vol 14.02.

⁵ Annual Book of ASTM Standards, Vol 03.05.

4. Ordering Information

4.1 Orders for product under this specification should include the following information:

- 4.1.1 ASTM designation and year of issue.
- 4.1.2 Type and class (Section 1),
- 4.1.3 Grain size (Section 7),
- 4.1.4 Dimensions and tolerances (see 8.1),
- 4.1.5 Drawing number to which order applies (see 8.1), and
- 4.1.6 Work test requirements if required (Section 11).
- 4.1.7 In addition, when material is purchased for agencies of the U.S. Government (see Supplementary Requirements section).

5. Material and Manufacture

5.1 Material:

5.1.1 The material of manufacture shall be annealed plate, sheet, strip, or disks of wrought Alloy UNS No. C22000 processed to produce even-topped cups.

5.2 Manufacture:

5.2.1 The material shall be blanked and cupped to meet the cup dimensions specified, and subsequently annealed, if required. The annealed cups shall be cleaned to provide a surface suitable for subsequent redrawing into bullet jackets.

6. Chemical Composition

6.1 The material shall conform to the chemical requirements prescribed in Table 1.

6.2 Limits may be established and analysis required for unnamed elements by agreement between manufacturer and purchaser.

6.3 Either copper or zinc may be taken as the difference between the sum of all elements analyzed and 100 %. When all elements in Table 1 are analyzed, the sum shall be 99.8 % min.

7. Grain Size of Annealed Tempers

7.1 Unless there is a prior agreement between the purchaser and supplier the grain size of class II cups shall be produced to have average grain size corresponding to the limits of the O5025 or O5040 tempers as specified in Table 2.

7.1.1 Grain size ranges other than those specified in Table 2 are to be established by agreement between manufacturer and purchaser.

7.2 Grain size ranges for other cups shall be established by agreement between manufacturer and purchaser.

TABLE 1 Chemical Requirements^A

Element	Composition, %
Copper	89.0–91.0
Lead, max	0.05
Iron, max	0.05
Zinc	remainder

^A If the presence of bismuth is suspected during analysis, further analysis shall be made to determine the concentration of this. If bismuth is found in excess of 0.006 %, the lot shall be rejected.

TABLE 2 Grain Size Requirements

Standard Designation (B 601)	Average Grain Size, mm		
	nominal	min	max
OS025	0.025	0.015	0.035
OS040	0.040	0.025	0.050

8. Dimensions, Mass, and Permissible Variations

8.1 All dimensions and tolerances of cups shall be as indicated on the drawings furnished with the purchase order or contract.

9. Workmanship, Finish, and Appearance

9.1 The cups shall be uniform in quality and shall be free of conditions which would interfere with the purpose for which the cups are intended.

10. Sampling

10.1 The lot size, portion size, and selection of pieces shall be as follows:

10.1.1 *Lot Size*—40 000 lb (18 144 kg) or fraction thereof.

10.1.2 *Portion Size*:

10.1.2.1 For chemical analysis—5 cups. In accordance with Practice E 255, drillings, millings, etc., shall be taken in approximately equal weight from each of the sample cups selected and combined into one composite sample. The minimum weight of the composite sample that is divided into three equal parts shall be 150 g. Each of the three equal parts shall be placed in a package and sealed: one for the seller, one for the purchaser, and one for an umpire.

10.1.2.2 For grain size determination—20 cups.

10.1.2.3 For the determination of dimensions—200 cups.

10.1.2.4 For the visual inspection—2000 cups.

10.1.2.5 For work tests—500 cups or 5000 cups, when and as required.

11. Number of Tests and Retests

11.1 *Visual Inspection*—Each cup in the sample shall be visually inspected.

11.1.1 *Major Defects*—Not more than 0.25 % of the cups in the sample shall contain the following major defects: scaly metal, deep scratches, laminations, slivers, laps, cracks, or wrinkles.

11.1.2 *Minor Defects*—Not more than 2 % of the cups in the sample shall contain the following minor defects: oily cup, greasy cup, dirty cup, oxidized cup, dented or bent edges, or scratches.

11.2 *Work Test*—If required by the purchase order or contract, one of the following work tests may be performed by the purchaser before approval of a lot for shipment:

11.2.1 Five hundred cups or more shall be subjected to a working test by processing them through the first drawing operation. The cups shall draw satisfactorily without showing defects that will cause them to be unsuitable for the purpose intended.

11.2.2 Five thousand cups shall be subjected to a working test by processing them satisfactorily into bullet jackets.

11.3 *Grain Size*—Each cup in the sample shall be tested.

11.3.1 If the material fails to pass the visual inspection examination or a work test, or if more than one specimen fails the grain size test, a retest shall be permitted on a sample double that of the original sample. The result of the retest or retests shall meet the specified requirements.

11.4 *Chemical Analysis*—An additional sample in accordance with 10.1.2.1 is permitted to be made and tested.

12. Specimen Preparation

12.1 For grain size measurements, either tangential grinding and polishing, or cutting, mounting, and polishing methods may be used to reach the zone (Fig. 1).

12.1.1 The test specimen shall be prepared in accordance with Practice E 3.

12.2 Specimens for chemical analysis shall be prepared in accordance with Practice E 255.

13. Test Methods

13.1 The properties and chemical composition enumerated in this specification shall, in case of disagreement, be determined in accordance with the following ASTM methods:

Test	ASTM Designation
Chemical analysis	E 478
Grain size	E 3, E112

13.2 The test method(s) used for determination of element(s) required by contractual or purchase order agreement shall be as agreed upon between the manufacturer and the purchaser.

13.3 Grain size measurements shall be made in a zone that is the approximate mid-point of the sidewall length and thickness of the cup as shown in Fig. 1. At least three

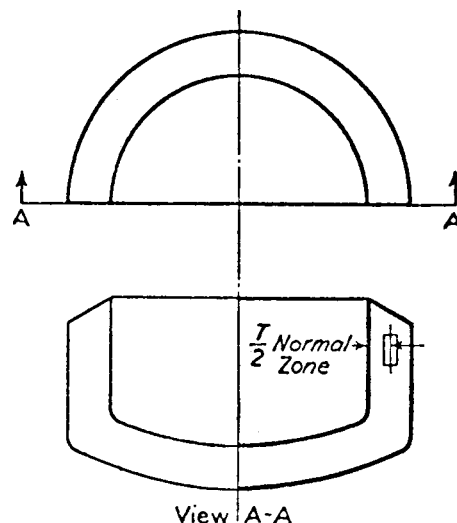

FIG. 1 Location of Areas to Be Examined for Grain Size in Bullet Jacket Cups

measurements shall be made, averaged, and recorded for each grain size determination.

14. Significance of Numerical Limits

14.1 For purposes of determining compliance with the specified limits for requirements of the properties listed in the following table, an observed value, or a calculated value, shall be rounded as indicated in accordance with the rounding method of Practice E 29.

Property	Rounded Unit for Observed or Calculated Value
Chemical composition	Nearest unit in the last right-hand significant digit used in expressing the limiting value
Grain size	Nearest multiple of 0.005 mm

15. Inspection

15.1 The manufacturer shall inspect and make the tests necessary to verify that the product furnished conforms to specification requirements.

15.2 *Measurement of Dimensions*—Each sample cup shall be gaged for compliance with all the dimensions shown on the applicable drawing. In addition, each cup in the sample shall be measured for sidewall thickness at two or more opposite points at the same distance from the mouth or base. The variation in wall thickness of any cup so measured shall be within the limits as shown on the drawing.

15.3 If, in addition, source inspection of the material by the purchaser is agreed upon between the manufacturer and the purchaser as part of the purchase order or contract, the nature of the facilities needed to satisfy the inspector representing the purchaser that the product is being furnished in accordance with this specification shall be included in the agreement. All tests and the inspection shall be conducted so as not to interfere unnecessarily with the operation of the works.

15.4 The manufacturer and the purchaser, by mutual agreement, may accomplish the final inspection simultaneously.

16. Rejection and Rehearing

16.1 *Rejection:*

16.1.1 Product that fails to conform to specification requirements when inspected or tested by the purchaser or his agent may be rejected.

16.1.2 Rejection shall be reported to the manufacturer or supplier promptly and in writing.

16.2 *Rehearing:*

16.2.1 As a result of product rejection, the manufacturer or supplier may make claim for a retest to be conducted by the manufacturer or supplier and the purchaser.

16.2.2 Samples of the rejected product shall be taken in accordance with the product specification and tested by both parties following the test method(s) specified in the product specification, or, alternatively, upon agreement of both parties, an independent laboratory may be selected for the test(s) following the specified test methods.

17. Certification

17.1 When specified in the contract or purchase order, the purchaser shall be furnished certification that samples representing each lot have been either tested or inspected as directed in this specification and the requirements have been met.

18. Packaging, and Package Marking

18.1 The product shall be separated by type and class, and prepared for shipment in such a manner as to ensure acceptance by common carrier for transportation and to afford protection from the normal hazards of transportation.

18.2 Each shipping unit shall be legibly marked with the purchase order number, type, class, gross and net weight, and name of supplier. The specification number shall be shown, when specified.

18.3 In addition to the above, specific instructions appearing on the purchase order or contract, or issued by the contracting officer, shall be adhered to unless, by mutual agreement, other provisions are established.

19. Test Report

19.1 When specified in the contract or purchase order, a report of test results shall be furnished.

20. Keywords

20.1 bullet jackets; commercial bronze cups

SUPPLEMENTARY REQUIREMENTS

The following supplementary requirements shall apply only when specified by the purchaser in the inquiry, contract, or order, for agencies of the U.S. Government.

S1. Scope

S1.1 The following supplementary requirements shall apply only when specified by the purchaser in the inquiry, contract, or order, for agencies of the U.S. Government.

S2. Referenced Documents

S2.1 The following documents of the issue in effect on date of material purchase form a part of this specification to the extent referenced herein:

S2.1.1 *Federal Standards:*⁶

Fed. Std. No. 102 Preservation, Packaging and Packing Levels

Fed. Std. No. 123 Marking for Shipment (Civil Agencies)

Fed. Std. No. 185 Identification Marking of Copper and Copper-Base Alloy Mill Products

S2.1.2 *Military Standard:*⁶

⁶ Available from Standardization Documents Order Desk, Bldg. 4 Section D, 700 Robbins Ave., Philadelphia, PA 19111-5094, Attn: NPODS.

MIL-STD-129 Marking for Shipment and Storage

S2.1.3 *Military Specification*.⁶

MIL-C-3993 Packaging of Copper and Copper-Base Alloy Mill Products

S3. Quality Assurance

S3.1 *Responsibility for Inspection*:

S3.1.1 Unless otherwise specified in the contract or purchase order, the manufacturer is responsible for the performance of all inspection and test requirements specified. Except as otherwise specified in the contract or purchase order, the manufacturer may use his own or any other suitable facilities for the performance of the inspection and test requirements unless disapproved by the purchaser at the time the order is placed. The purchaser shall have the right to perform any of the inspections and tests set forth in this specification when such inspections and tests are deemed necessary to assure that the material conforms to the prescribed requirements.

S4. Identification Marking

S4.1 All material shall be properly marked for identification in accordance with Fed. Std. No. 185 except that the ASTM specification number and the alloy number shall be used.

S5. Preparation for Delivery

S5.1 *Preservation, Packaging, Packing*:

S5.1.1 *Military Agencies*—The material shall be separated by size, composition, grade, or class and shall be preserved and packaged, Level A or C, packed Level A, B, or C, as specified in the contract or purchase order, in accordance with the requirements of MIL-C-3993.

S5.1.2 *Civil Agencies*—The requirements of Fed. Std. No. 102 shall be referenced for definitions of the various levels of packaging protection.

S5.2 *Marking*:

S5.2.1 *Military Agencies*—In addition to any special marking required by the contract or purchase order, marking for shipment shall be in accordance with MIL-STD-129.

S5.2.2 *Civil Agencies*—In addition to any special marking required by the contract or purchase order, marking for shipment shall be in accordance with Fed. Std. No. 123.

SUMMARY OF CHANGES

This section identified principle changes to this specification since the last issue. This document received a five year review with extensive form and style changes.

- 1) Section 1.2—adjusted SI note.
- 2) Added Section 3—Terminology.
- 3) Added Section 12—Specimen Preparation.
- 4) Added Section 17—Certification.
- 5) Added Section 19—Test Report.
- 6) Added Section 20—Keywords.

The American Society for Testing and Materials takes no position respecting the validity of any patent rights asserted in connection with any item mentioned in this standard. Users of this standard are expressly advised that determination of the validity of any such patent rights, and the risk of infringement of such rights, are entirely their own responsibility.

This standard is subject to revision at any time by the responsible technical committee and must be reviewed every five years and if not revised, either reapproved or withdrawn. Your comments are invited either for revision of this standard or for additional standards and should be addressed to ASTM Headquarters. Your comments will receive careful consideration at a meeting of the responsible technical committee, which you may attend. If you feel that your comments have not received a fair hearing you should make your views known to the ASTM Committee on Standards, 100 Barr Harbor Drive, West Conshohocken, PA 19428.