



# Standard Practice for Preparing Tension Test Specimens for Copper Alloy Sand, Permanent Mold, Centrifugal, and Continuous Castings<sup>1</sup>

This standard is issued under the fixed designation B 208; the number immediately following the designation indicates the year of original adoption or, in the case of revision, the year of last revision. A number in parentheses indicates the year of last reapproval. A superscript epsilon ( $\epsilon$ ) indicates an editorial change since the last revision or reapproval.

*This standard has been approved for use by agencies of the Department of Defense.*

## 1. Scope\*

1.1 This practice establishes procedures for preparing test coupons and specimens (machined and unmachined) for tension tests of copper alloys for sand, permanent mold, centrifugal and continuous castings.

1.2 The values stated in inch-pound units are the standard. SI values given in parentheses are for information only.

## 2. Referenced Documents

2.1 *ASTM Standards*:<sup>2</sup>

B 846 Terminology for Copper and Copper Alloys

## 3. Terminology

3.1 Definitions of terms relating to copper alloys can be found in Terminology B 846.

## 4. Significance and Use

4.1 The mechanical properties determined from test bars for sand, permanent mold, and centrifugal castings poured in accordance with this practice represent the properties of the metal going into castings poured from the same heat. These mechanical properties may not be the same as the properties of the corresponding castings because of the solidification effects of varying size, section, and design.

4.2 Test bars for continuous castings are taken from the castings and therefore represent the properties of the castings.

## 5. Test Coupons

5.1 *Sand Castings*—The test bar coupons shall be made by the same manufacturing process as the castings they represent wherever possible. If the castings are cast entirely in green sand, partial cores shall be permitted for the test bars but in no

case shall chills be permitted. Unless otherwise agreed upon between the manufacturer and purchaser, test bars may be poured in cores on a production line. The use of filters in the gating system is permitted.

5.1.1 *High-Shrinkage Sand-Cast Alloys*—The test specimen coupons for copper casting alloys exhibiting high shrinkage during freezing and cooling shall be cast to the form and dimensions shown in Fig. 1 (a or b) or 2 (a or b). If specimens having threaded ends are to be used in the tension tests, the length of the keel blocks in Fig. 1a may be reduced to 6¼ in. (159 mm). See Appendix X1 for SI equivalents.

5.1.2 *Low-Shrinkage Sand-Cast Alloys*—The test specimen coupons for copper casting alloys exhibiting low shrinkage during freezing and cooling shall be cast to the form and dimensions shown in Fig. 2 (A or B), Fig. 3, or Fig. 4 or as may be prescribed in the casting specifications.

5.2 *Centrifugal Castings*—Unless otherwise specified by the purchaser, the manufacturer shall pour the test bars in the same type of mold as the castings themselves. That is, test bars for sand mold castings shall be poured in sand molds, and test bars for chill mold castings shall be poured in chill molds.

5.2.1 The centrifugally cast test specimen coupons shall be cast to the form and dimensions of Fig. 5.

5.3 *Continuous Castings*—Test bars shall be taken from the continuous cast product. Test bars may be taken before mechanical straightening.

5.3.1 Test bar coupons shall be taken in a longitudinal direction from the continuous cast product at the mid-wall of hollow castings or at one-half the distance between the center and the side of solid castings as illustrated in Fig. 6.

5.3.2 For irregular shapes, the location of the test bar coupon shall be as agreed upon between the manufacturer and purchaser.

5.3.3 Transverse test specimens are allowed for continuous cast product having a cross section thickness, diameter, or wall of 4 in. or more. The cross sections are the diameter of a round solid, the distance across flats of a solid hexagon, the thickness of a rectangle, and the wall thickness of a tube.

5.4 *Permanent Mold Castings*—The test bar coupons shall be made in the permanent die for test bars shown in Fig. 7 or Fig. 9. The runner, gate, and risers shall be coated with an

<sup>1</sup> This practice is under the jurisdiction of ASTM Committee B05 on Copper and Copper Alloys and is the direct responsibility of Subcommittee B05.05 on Castings and Ingots for Remelting.

Current edition approved May 1, 2004. Published June 2004. Originally approved in 1946. Last previous edition approved in 2003 as B 208 – 96 (2003).

<sup>2</sup> For referenced ASTM standards, visit the ASTM website, [www.astm.org](http://www.astm.org), or contact ASTM Customer Service at [service@astm.org](mailto:service@astm.org). For *Annual Book of ASTM Standards* volume information, refer to the standard's Document Summary page on the ASTM website.

\*A Summary of Changes section appears at the end of this standard.

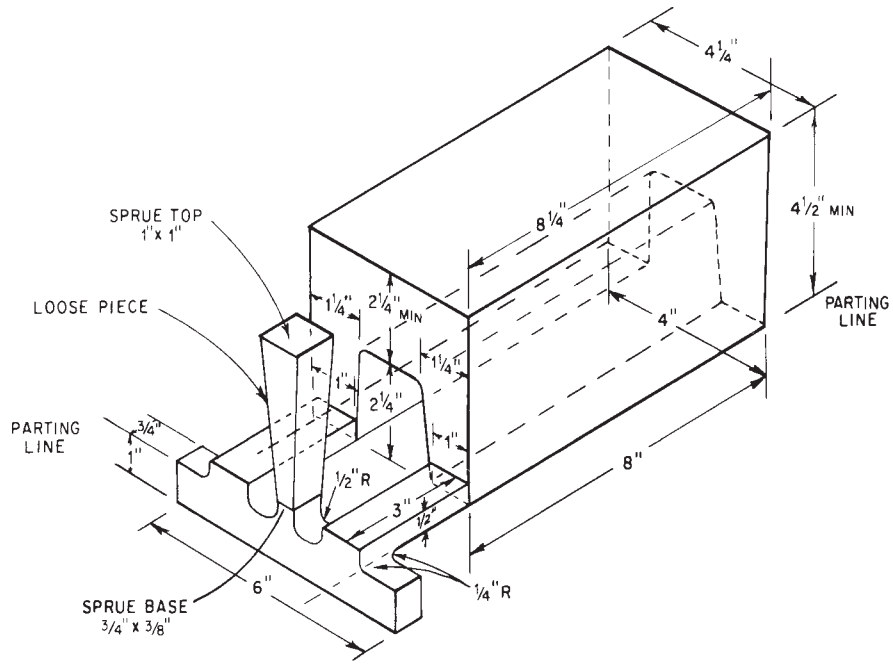

(a) Bottom Gating

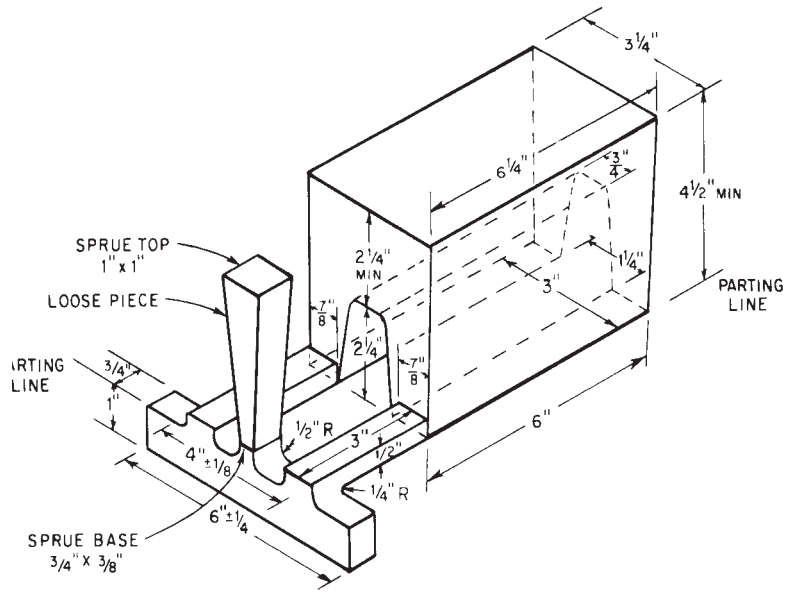

(b) Bottom Gating (Lower Weight Version)

NOTE 1—Where this type of test bar design is used, bottom gating is recommended for alloys such as aluminum bronze, where turbulence and oxidation are factors.

FIG. 1 Double Keel Block Test Bar

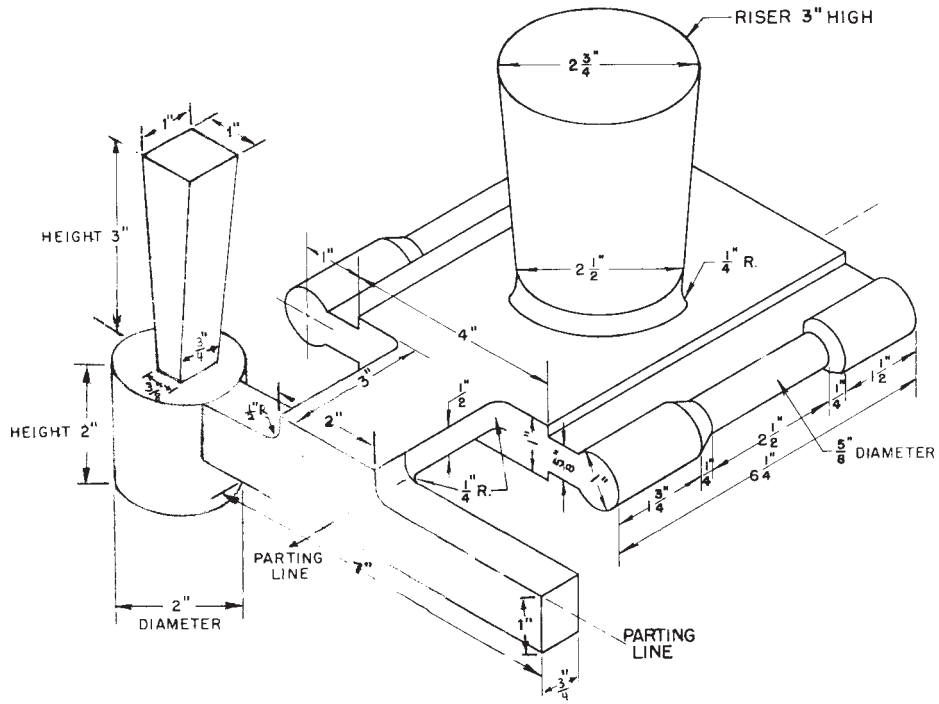

FIG. 2a Double Horizontal Full-Web Type Test Bars

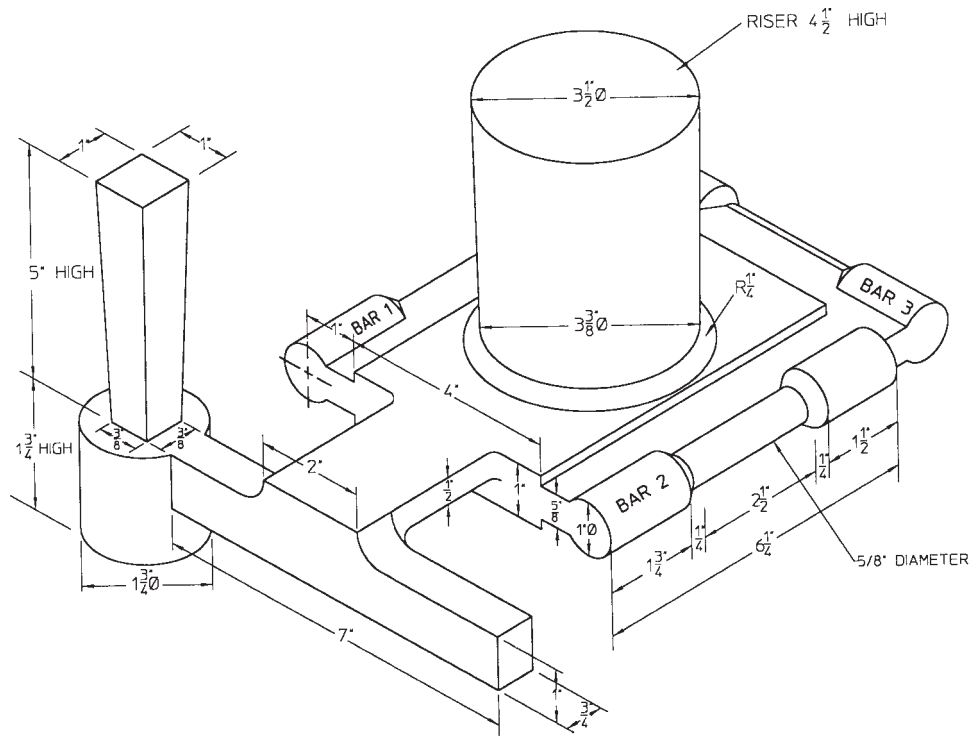
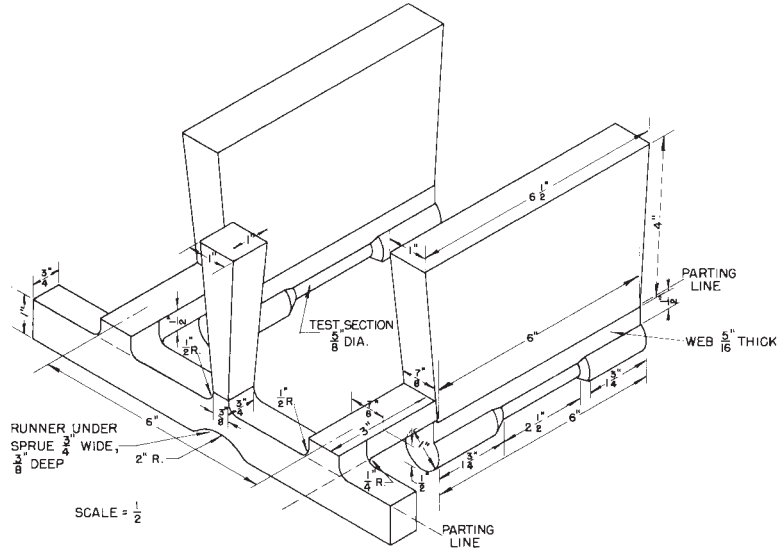
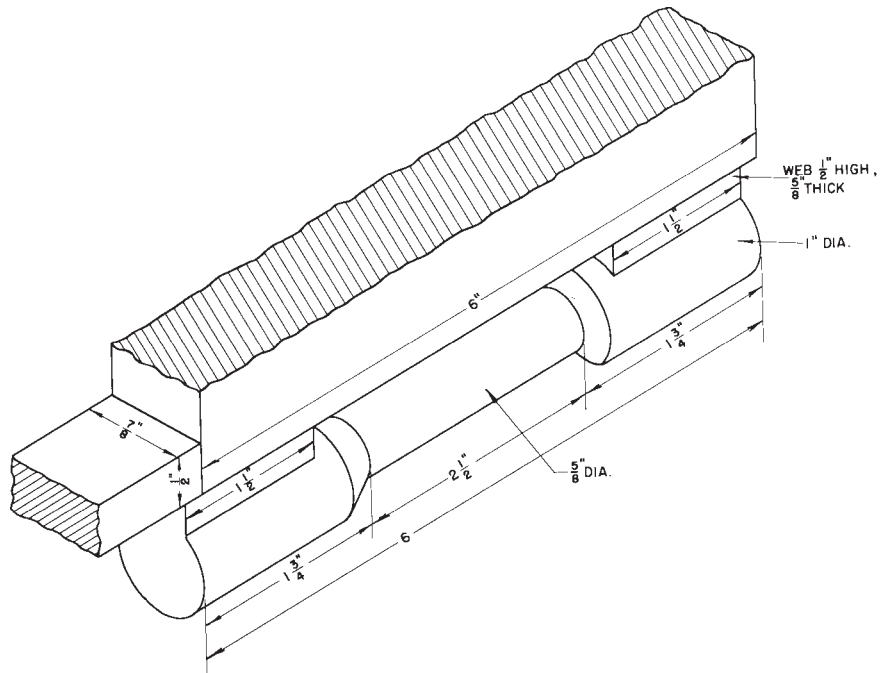

FIG. 2 b Triple Full-Web Type Test Bar



(a) Gating Design for Double Vertical Full-Web or Grip-Web Type Bars (Full-Web Bars Being Cast)



(b) Design of the Vertical Grip-Web Bar (Gating and Riser System as in ( a))

**FIG. 3 Double Vertical Full-Web and Grip-Web Type Test Bars**

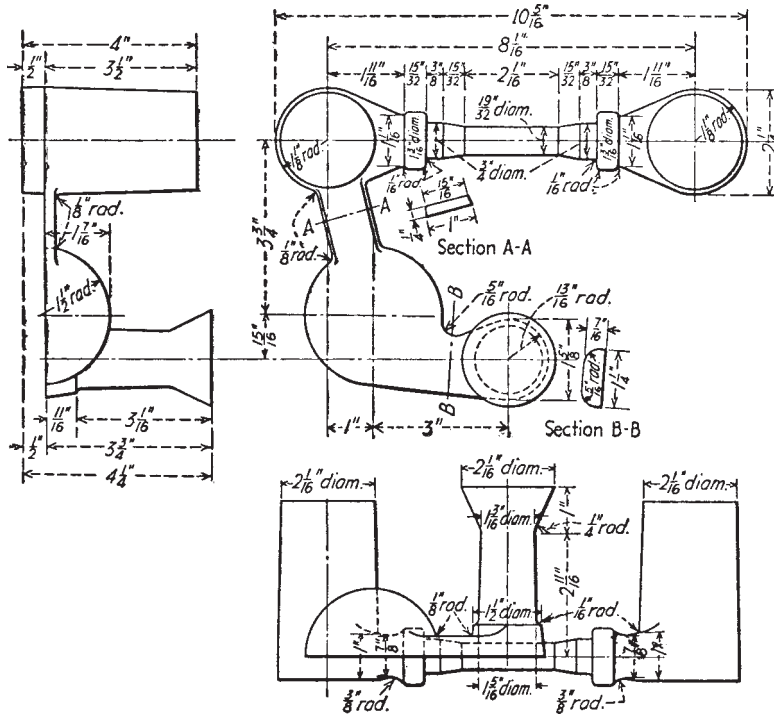

FIG. 4 Optional Coupon for As-Cast Tension Test Specimen, Button Head

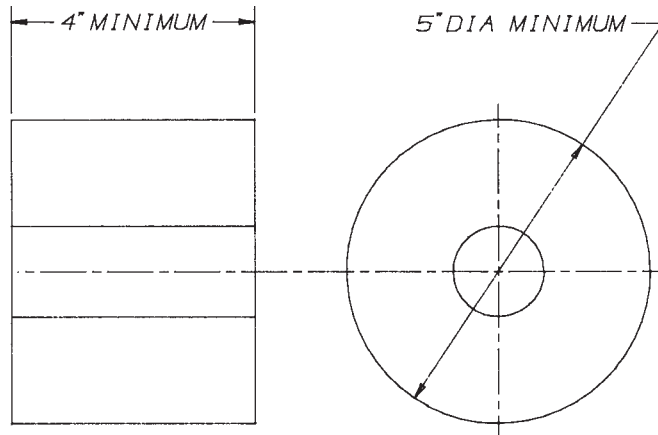

FIG. 5 Centrifugal Cast Test Bar

insulating spray. The test bar cavity shall be coated with a graphite spray. Test bar casting shall be poured in the tilted position and rotated to the vertical position during pouring.

**6. Test Specimens**

6.1 *Sand Cast*—Tension test specimens shall be machined from the coupons described in 5.1.1 and 5.1.2 and shown in Fig. 1, Fig. 2, and Fig. 3. They shall be of the form and dimensions shown in Fig. 11 for the 0.500-in. standard test bar specimen.

6.1.1 In the case of test specimens prepared from the coupons in Fig. 4, the manufacturer shall have the option of testing the specimens without machining the gage length. If the specimens are machined, the gage length, parallel sections, and fillets shall be machined to the dimensions shown in Fig. 11.

6.2 *Centrifugally Cast*—Tension test specimens shall be machined from the coupons described in 5.2.1 and shown in Fig. 5. They shall be of the form and dimensions shown in Fig. 11.

6.3 *Continuous Cast*—Tension test specimens shall be machined from the continuous cast product as described in 5.3.1 and shown in Fig. 6. They shall be of the form and dimensions as shown in Fig. 11.

6.4 *Permanent Mold*—Tension test specimens shall be cut from the test bar coupon shown in Fig. 7 or Fig. 9 and shall be of the form and dimensions shown in Figs. 8 and 10.

NOTE 1—The dimensions for the die shown in Fig. 7 or Fig. 9 are “standard rule.” After solidification and cooling, a tension test specimen of the form and dimensions of Figs. 8 and 10 will be produced by the die shown in Fig. 7 or Fig. 9.

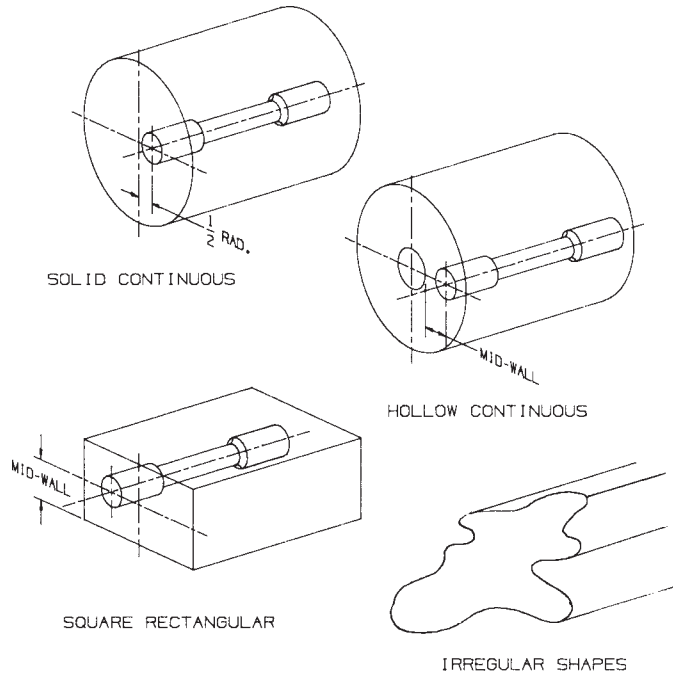

**FIG. 6 Continuous Cast Test Bar**

6.4.1 The gage length and reduced section shall be as cast, but the ends may be machined to fit the holders of the testing machine in such a way that the load shall be axial.

**7. Keywords**

7.1 copper alloys; copper alloy castings; tension test specimens

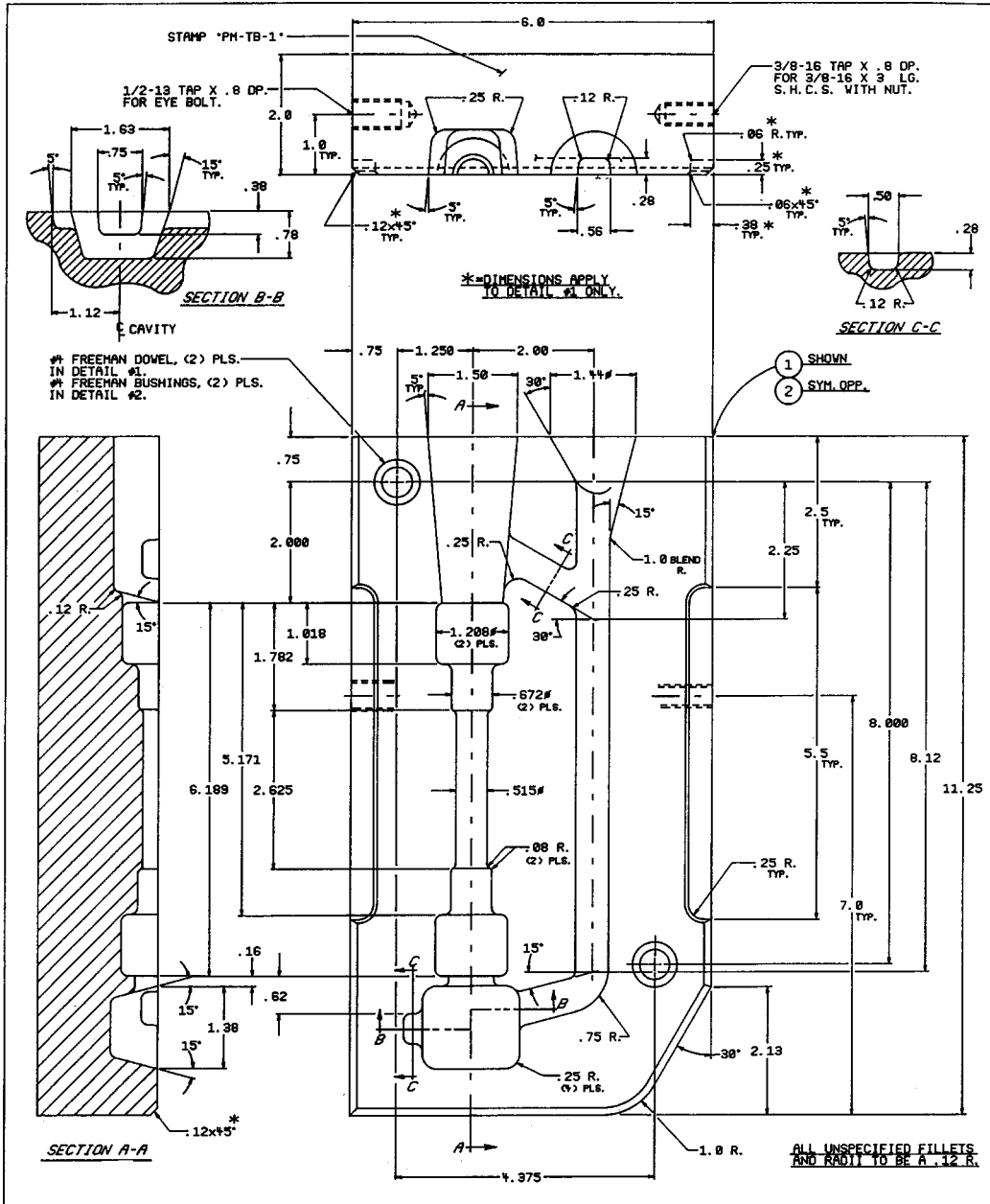

FIG. 7 Permanent Mold Test Bar Die

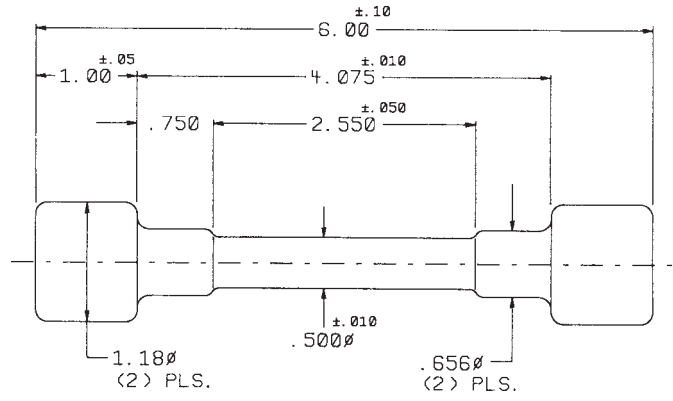

FIG. 8 Permanent Mold As-Cast Test Bar Obtained from Permanent Mold Die in Fig. 7

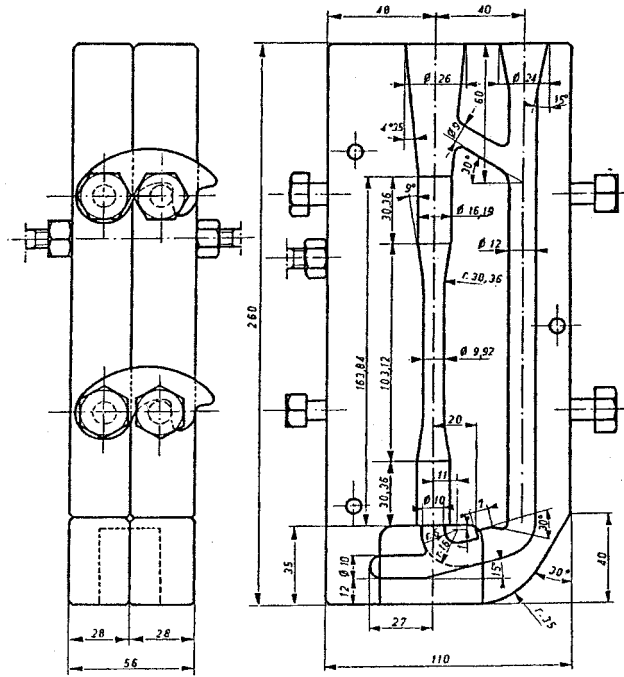

FIG. 9 Permanent Mold Test Bar Die



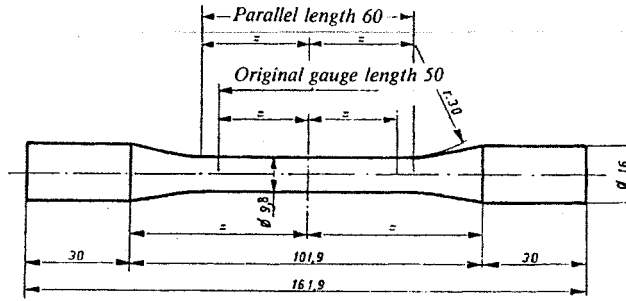
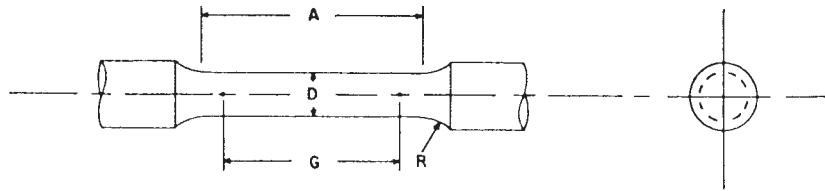

FIG. 10 Permanent Mold As-Cast Test Bar Obtained from Permanent Mold Die in Fig. 9



Dimensions

	Standard Specimen		Small-Size Specimens Proportional to Standard		
	in.	in.	in.	in.	in.
Nominal Diameter	0.500	0.350	0.250	0.160	0.113
G—Gage length	2.000 ± 0.005	1.400 ± 0.005	1.000 ± 0.005	0.640 ± 0.005	0.450 ± 0.005
D—Diameter (Note 1)	0.500 ± 0.010	0.350 ± 0.007	0.250 ± 0.005	0.160 ± 0.003	0.113 ± 0.002
R—Radius of fillet, min	3/8	1/4	3/16	5/32	3/32
A—Length of reduced section, min Note 2 )	2 1/4	1 3/4	1 1/4	3/4	5/8

NOTE 1—The reduced section may have a gradual taper from the ends toward the center, with the ends not more than 1 % larger in diameter than the center (controlling dimension).

NOTE 2—If desired, the length of the reduced section may be increased to accommodate an extensometer of any convenient gage length. Reference marks for the measurement of elongation should, nevertheless, be spaced at the indicated gage length.

NOTE 3—The gage length and fillets may be as shown, but the ends may be of any form to fit the holders of the testing machine in such a way that the load shall be axial (see Figs. 8 and 10). If the ends are to be held in wedge grips it is desirable, if possible, to make the length of the grip section great enough to allow the specimen to extend into the grips a distance equal to two thirds or more of the length of the grips.

NOTE 4—On the round specimens in Fig. 11 and Figs. 8 and 10, the gage lengths are equal to four times the nominal diameter. In some product specifications other specimens may be provided for, but unless the 4-to-1 ratio is maintained within dimensional tolerances, the elongation values may not be comparable with those obtained from the standard test specimen.

NOTE 5—The use of specimens smaller than 0.250-in. diameter shall be restricted to cases when the material to be tested is of insufficient size to obtain larger specimens or when all parties agree to their use for acceptance testing. Similar specimens require suitable equipment and greater skill in both machining and testing.

NOTE 6—Five sizes of specimens often used have diameters of approximately 0.505, 0.357, 0.252, 0.160, and 0.113 in., the reason being to permit easy calculations of stress from loads, since the corresponding cross-sectional areas are equal or close to 0.200, 0.100, 0.0500, 0.0200, and 0.0100 in.<sup>2</sup>, respectively. Thus, when the actual diameters agree with these values, the stresses (or strengths) may be computed using the simple multiplying factors 5, 10, 20, 50, and 100, respectively. (The metric equivalents of these five diameters do not result in correspondingly convenient cross-sectional areas and multiplying factors.)

FIG. 11 Standard 0.500-in. Round Tension Test Specimen with 2-in. Gage Length and Examples of Small-Size Specimens Proportional to the Standard Specimen

**APPENDIX**
**(Nonmandatory Information)**
**X1. SI EQUIVALENTS FOR NUMERICAL VALUES SHOWN IN Figs. 1-10**
**TABLE X1.1 SI Equivalents for Numerical Values Shown in Figs. 1-10**

in.	mm	in.	mm	in.	mm
0.005	0.13	$\frac{7}{8}$	22.2	$2\frac{1}{2}$	63.5
0.01	0.25	$1\frac{5}{16}$	23.8	$2\frac{3}{4}$	69.8
0.50	12.7	1	25.4	3	76.2
$\frac{1}{16}$	1.59	$1\frac{1}{16}$	27.0	$3\frac{1}{16}$	77.8
$\frac{1}{8}$	3.18	$1\frac{1}{8}$	28.6	$3\frac{3}{8}$	85.7
$\frac{1}{4}$	6.35	$1\frac{3}{16}$	30.2	$3\frac{1}{2}$	88.9
				$3\frac{3}{4}$	95.2
$\frac{9}{32}$	7.14	$1\frac{1}{4}$	31.8	4	102
$\frac{5}{16}$	7.94	$1\frac{5}{16}$	33.3	$4\frac{1}{4}$	108
$\frac{3}{8}$	9.52	$1\frac{7}{16}$	36.5	$4\frac{1}{2}$	114
				$4\frac{3}{4}$	121
				5	127
				$5\frac{1}{2}$	140
$\frac{7}{16}$	11.1	$1\frac{1}{2}$	38.1	6	152
$1\frac{5}{32}$	11.9	$1\frac{5}{8}$	41.3	$6\frac{1}{4}$	159
$\frac{1}{2}$	12.7	$1\frac{11}{16}$	52.9	$6\frac{1}{2}$	165
$\frac{5}{8}$	15.9	$1\frac{3}{4}$	44.4	8	203
$1\frac{1}{16}$	17.5	2	50.8	$8\frac{1}{16}$	205
$\frac{3}{4}$	19.0	$2\frac{1}{16}$	52.4	$8\frac{1}{4}$	210
$1\frac{3}{16}$	20.6	$2\frac{1}{4}$	57.2	9	229
				$9\frac{1}{2}$	241
				$10\frac{15}{16}$	278

**SUMMARY OF CHANGES**

Committee B05 has identified the location of selected changes to this standard since the last issue (B 208 – 96 (2003)) that may impact the use of this standard. (Approved May 1, 2004.)

- (1) A Referenced Document section was added. (2) New figures Fig. 9 and Fig. 10 were added.

*ASTM International takes no position respecting the validity of any patent rights asserted in connection with any item mentioned in this standard. Users of this standard are expressly advised that determination of the validity of any such patent rights, and the risk of infringement of such rights, are entirely their own responsibility.*

*This standard is subject to revision at any time by the responsible technical committee and must be reviewed every five years and if not revised, either reapproved or withdrawn. Your comments are invited either for revision of this standard or for additional standards and should be addressed to ASTM International Headquarters. Your comments will receive careful consideration at a meeting of the responsible technical committee, which you may attend. If you feel that your comments have not received a fair hearing you should make your views known to the ASTM Committee on Standards, at the address shown below.*

*This standard is copyrighted by ASTM International, 100 Barr Harbor Drive, PO Box C700, West Conshohocken, PA 19428-2959, United States. Individual reprints (single or multiple copies) of this standard may be obtained by contacting ASTM at the above address or at 610-832-9585 (phone), 610-832-9555 (fax), or service@astm.org (e-mail); or through the ASTM website (www.astm.org).*