



Standard Specification for Copper Rod Drawing Stock for Electrical Purposes¹

This standard is issued under the fixed designation B 49; the number immediately following the designation indicates the year of original adoption or, in the case of revision, the year of last revision. A number in parentheses indicates the year of last reapproval. A superscript epsilon (ϵ) indicates an editorial change since the last revision or reapproval.

This standard has been approved for use by agencies of the Department of Defense.

1. Scope*

1.1 This specification covers the requirements for rod drawing stock in diameters from $\frac{1}{4}$ to $1\frac{3}{8}$ in. (6.4 to 35 mm) produced from electrolytic tough-pitch or oxygen-free coppers and are suitable for further fabrication into electrical conductors.

1.2 The values stated in inch-pound units are the standard. The values given in parentheses are for information only.

1.3 The following safety hazards caveat pertains only to Section 13. *This standard does not purport to address all of the safety concerns, if any, associated with its use. It is the responsibility of the user of this standard to establish appropriate safety and health practices and determine the applicability of regulatory limitations prior to use.*

2. Referenced Documents

2.1 The following documents in the current issue of the Book of Standards form a part of this specification to the extent referenced herein and define materials suitable for use in rod manufacture:

2.2 ASTM Standards:²

- B 5 Specification for High Conductivity Tough-Pitch Copper Refinery Shapes
- B 115 Specification for Electrolytic Copper Cathode
- B 170 Specification for Oxygen-Free Electrolytic Copper—Refinery Shapes
- B 193 Test Method for Resistivity of Electrical Conductor Materials
- B 224 Classification of Coppers
- B 577 Test Methods for Detection of Cuprous Oxide (Hydrogen Embrittlement Susceptibility) in Copper
- B 846 Terminology for Copper and Copper Alloys
- E 8 Test Methods for Tension Testing of Metallic Materials

- E 18 Test Methods for Rockwell Hardness and Rockwell Superficial Hardness of Metallic Materials
- E 29 Practice for Using Significant Digits in Test Data to Determine Conformance with Specifications
- E 53 Test Methods for Determination of Copper in Unalloyed Copper by Gravimetry
- E 478 Test Methods for Chemical Analysis of Copper Alloys

2.3 Other Document:

- NBS Handbook 100 *Copper Wire Tables*³

3. Terminology

3.1 For definitions of general terms relating to copper and copper alloys refer to Terminology B 846.

4. Ordering Information

4.1 Orders for rod under this specification shall include the following information:

- 4.1.1 ASTM designation and year of issue,
- 4.1.2 Quantity of each size,
- 4.1.3 Type and requirements of copper (Sections 5-10),
- 4.1.4 Finish (Sections 9 and 10),
- 4.1.5 Package with or without joints (see 5.3),
- 4.1.6 Rod diameter (see 9.2),
- 4.1.7 Inspection (Section 15),
- 4.1.8 Package size (see 19.1), and
- 4.1.9 Special package marking as agreed upon between the manufacturer and the purchaser (Section 19).

4.2 The following requirements are optional and should be specified in the contract or purchase order when required.

- 4.2.1 Certification (Section 17) and
- 4.2.2 Test Report (Section 18).

5. Material and Manufacture

5.1 The rod shall be fabricated from copper of such quality and purity that the finished product shall have the properties and characteristics prescribed in this specification.

NOTE 1—The following specifications define materials suitable for use:

³ Available from the National Technical Information Service, 5285 Port Royal Rd., Springfield, VA 22161.

¹ This specification is under the jurisdiction of ASTM Committee B05 on Copper and Copper Alloys and is the direct responsibility of Subcommittee B05.07 on Refined Copper.

Current edition approved May 1, 2004. Published May 2004. Originally approved in 1923. Last previous edition approved in 1998 as B 49 – 98 ϵ^2 .

² For referenced ASTM standards, visit the ASTM website, www.astm.org, or contact ASTM Customer Service at service@astm.org. For *Annual Book of ASTM Standards* volume information, refer to the standard's Document Summary page on the ASTM website.

*A Summary of Changes section appears at the end of this standard.

Specification B 5, or Specification B 115, or Specification B 170.

5.2 Copper of special qualities, forms, or types, as agreed upon between the manufacturer and the purchaser and that will conform to the requirements prescribed in this specification may also be used.

5.3 The rod coils shall be furnished in continuous lengths with or without joints, as ordered.

TABLE 1 Chemical Composition^A

UNS Number Copper Type	C11040 ETP ^B	C10100 OFE ^C	C10200 OF ^D	C11000 ETP
Copper, min	99.90 % ^E	99.99 % ^E	99.95 % ^F incl silver	99.90 % ^F incl silver
	ppm	ppm	ppm	ppm
Tellurium, max	2	2
Selenium, max	2	3
Bismuth, max	1.0	1.0
Group total, max	3
Antimony, max	4	4
Arsenic, max	5	5
Tin, max	5	2
Lead, max	5	5
Iron, max	10	10
Nickel, max	10	10
Sulfur, max	15	15
Silver, max	25	25
Oxygen	100–650	5 max	10 max	...
Maximum allowable total	65 ^G
Cadmium, max	...	1
Phosphorus, max	...	3
Zinc, max	...	1
Manganese, max	...	0.5

^A See 13.1.2.

^B From B 115 Grade 1 copper or equivalent.

^C From B 170 Grade 1 copper or equivalent.

^D From B 170 Grade 2 copper or equivalent.

^E By difference. See 13.1.2 and 13.1.3.

^F See 13.1.1.

^G Not including oxygen.

6. Chemical Composition

6.1 Each rod type shall conform to the chemical composition requirements prescribed in Table 1 for the type of copper ordered (Section 4).

6.2 By agreement between the manufacturer and the purchaser, the addition of silver up to an average of 30 troy oz per short ton of copper (0.10 %) will be considered within the specification, copper including silver in the chemical analysis, with no individual silver analysis to exceed 35 troy oz per short ton (0.12 %). In the case of oxygen-free silver-bearing coppers, the designation OFS (oxygen-free, silver-bearing) will be used as shown in Classification B 224 and will include the UNS Nos. C10400, C10500, and C10700 as defined by the agreed silver content.

6.3 Silver-bearing tough-pitch copper corresponds to the designation STP (silver-bearing tough-pitch) as shown in Classification B 224 and to coppers having UNS Nos. C11300, C11400, C11500, and C11600.

6.4 *Oxygen Content*—Oxygen-free copper as described herein is defined as a copper containing not in excess of 0.0010 % (10 ppm) oxygen and produced without the use of metallic or other deoxidizers.

7. Physical Property Requirements

7.1 *Electrical Resistivity*—Resistivity of the copper in the annealed condition (See Note X1.1) shall not exceed the following values at 20°C:

Type of Copper	Resistivity, max, at 20°C Annealed, Ω · g/m ²
UNS C10100 only	0.15176 (101.00 % IACS min)
All others	0.15328 (100.00 % IACS min)

8. Mechanical Property Requirements

8.1 *Tensile Tests*—Rod finished by hot working or annealing shall have a minimum elongation of 30 % in 10 in. (250 mm). (Note X1.2 and Test Methods E 8.)

8.2 *Torsion Tests*—If torsion tests are requested, refer to Note X1.3.

8.3 *Embrittlement (Bend) Test*:

8.3.1 A test to reflect propensity towards hydrogen embrittlement shall be performed only on oxygen-free copper.

8.3.2 The specimen shall be tested in accordance with 13.6 and Specification B 170.

8.3.3 The specimen, prepared and tested from the OFE (oxygen-free electronic) copper (UNS C10100) listed in Table 1, shall withstand without breaking into two pieces, a minimum of ten (10) reverse bends.

8.3.4 The specimen, prepared and tested from the OF (oxygen-free) copper (UNS C10200) listed in Table 1, shall withstand, without breaking into two pieces, a minimum of eight (8) reverse bends.

8.4 *Annealability*—Annealability is not a requirement of this specification. However, a discussion will be found in Notes X1.4-X1.6.

9. Other Requirements

9.1 *Surface Oxide*—The surface oxide film thickness shall be determined in accordance with 13.5.

9.1.1 Total thickness of the copper oxide film on cleaned copper rod or annealed shaved rod or cold-finished rod shall not exceed 1000 Å (10⁻⁷ m).

9.1.2 The residual oxide film thickness on as-shaved rod does not need to be specified.

9.1.3 A surface oxide requirement is not necessary for rod ordered uncleaned.

9.2 *Diameter*—The diameter of the rod at any point shall not vary from that specified by more than the amounts prescribed in Table 2.

TABLE 2 Permissible Variations in Diameter

Nominal Diameter, in. (mm)	Permissible Variation, in. (mm)
¼ (6.4)	+0.020 (+0.51) -0.010 (-0.25)
Over ¼ (6.4) to ¾ in. (19 mm) incl.	±0.015 (±0.38)
Over ¾ (19) to 1.0 in. (25 mm) incl.	±0.020 (±0.51)
Over 1.0 (25) to 1½ in. (35 mm) incl.	±0.030 (±0.76)

TABLE 3 Equivalent Resistivity Values^A

Conductivity at 68°F (20°C), % IACS	100.00	101.00
$\Omega \cdot \text{lb}/\text{mile}^2$	875.20	866.53
$\Omega \cdot \text{g}/\text{m}^2$	0.153 28	0.151 76
$\Omega \cdot \text{c mil}/\text{ft}$	10.371	10.268
$\Omega \cdot \text{mm}^2/\text{m}$	0.017 241 0	0.017 070
$\mu\Omega \cdot \text{in.}$	0.678 79	0.672 07
$\mu\Omega \cdot \text{cm}$	1.7241	1.7070

^A The equivalent resistivity values for 100 % IACS (soft copper) were each computed from the fundamental IEC value (1/58 $\Omega \cdot \text{mm}^2/\text{m}$) using conversion factors each accurate to at least seven significant figures.

10. Workmanship, Finish and Appearance

10.1 The rod shall be free of defects, but blemishes of a nature that do not interfere with the intended application are acceptable.

11. Sampling

11.1 This procedure shall be used in case of dispute between the manufacturer and the purchaser.

11.2 One sample shall be taken from each 200 000-lb (90 000-kg) lot for resistivity, elongation, surface oxide, embrittlement (bend) test, and chemical analysis.

11.3 When a cast refinery shape has been chemically analyzed and converted into rod without remelting, further chemical analysis shall not be required.

12. Number of Tests and Retests

12.1 Tests:

12.1.1 *Chemical Analysis*—Chemical composition shall be determined as per the element mean of the results from at least two replicate analyses of the sample(s).

12.1.2 Other Tests:

12.1.2.1 *Electrical Resistivity, Elongation, and Surface Oxide*—Results shall be reported as the average obtained from at least two test specimens, each taken from a separate test piece where possible.

12.1.2.2 *Hydrogen Embrittlement Test and Microscopical Examination*—All specimens tested must meet the requirements of the specification.

12.2 Retests:

12.2.1 When requested by the manufacturer or supplier, a retest shall be permitted when results of tests obtained by the purchaser fail to conform to the requirements of the product specification.

12.2.2 The retest shall be as directed in the product specification for the initial test except the number of test specimens shall be twice that normally required for the specified test.

12.2.3 All test specimens shall conform to the product specification requirement(s) in retest. Failure to conform shall be cause for rejection.

13. Test Methods

13.1 Chemical Analysis:

13.1.1 In case of dispute, determine copper content of the coppers other than UNS C10100 and UNS C11040 in Table 1 in accordance with Test Method E 53.

13.1.2 Analytical method for determining impurity levels of coppers listed in Table 1 shall be in accordance with Specification B 115.

13.1.3 Calculate copper content of UNS C10100 and UNS C11040 types by subtracting from 100 % the total impurity concentration determined. The impurity total for UNS C10100 is defined as the sum of sulfur, silver, lead, tin, bismuth, arsenic, antimony, iron, nickel, zinc, phosphorus, selenium, tellurium, manganese, cadmium, and oxygen present in the sample. The impurity total for UNS C11040 is defined as the sum of sulfur, silver, lead, tin, bismuth, arsenic, antimony, iron, nickel, selenium, tellurium, and oxygen present in the sample.

13.1.4 The test methods annex of Specification B 170 should be referenced for the oxygen-free coppers. Test Method E 478 should be referenced for the determination of silver-bearing alloys permitted under this specification.

13.1.5 Oxygen content is determined on cleaned copper samples using a suitable laboratory apparatus or a commercial instrument designed specifically for this purpose. An ASTM method has not been developed.

13.2 *Elongation*—Determine the elongation as the permanent increase in length, caused by breaking of the rod in tension, measured between gage marks placed originally 10 in. (250 mm) apart upon the test specimen (Note X1.2). The fracture shall be between gage marks and not closer than 1 in. (25 mm) to either gage mark.

13.3 Electrical Resistivity:

13.3.1 At the option of the manufacturer, electrical resistivity may be determined in accordance with 13.3.2 or 13.3.3. However, in case of dispute, 13.3.2 shall apply.

13.3.2 Make resistance measurements (Note X1.3) on specimens of the rod after cleaning and processing down to a diameter of approximately 0.080 in. (2.0 mm) and annealing at approximately 932°F (500°C) for 30 min. Other equivalent annealing methods may be used. Test specimens processed to a diameter other than 0.080 in. may be used if agreed upon between the manufacturer and the purchaser.

13.3.3 Resistance measurements may be determined on specimens of the rod after cleaning, but without further processing and annealing. However, in the event of failure of a rod specimen to conform to the criteria of 7.1, a retest is permitted using the procedure of 13.3.2.

13.3.4 Determine the electrical resistivity in accordance with Test Method B 193 except that when the option of 13.3.3 is elected, the plus and minus tolerance for the cross-sectional area as specified in Test Method B 193 shall not apply.

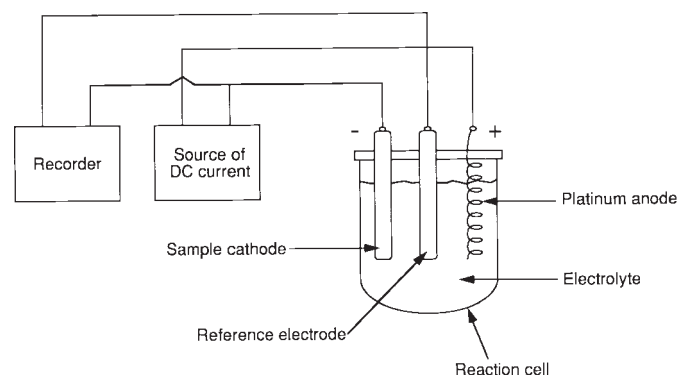

FIG. 1 Schematic Illustration Showing Electrolytic Reduction Test Method

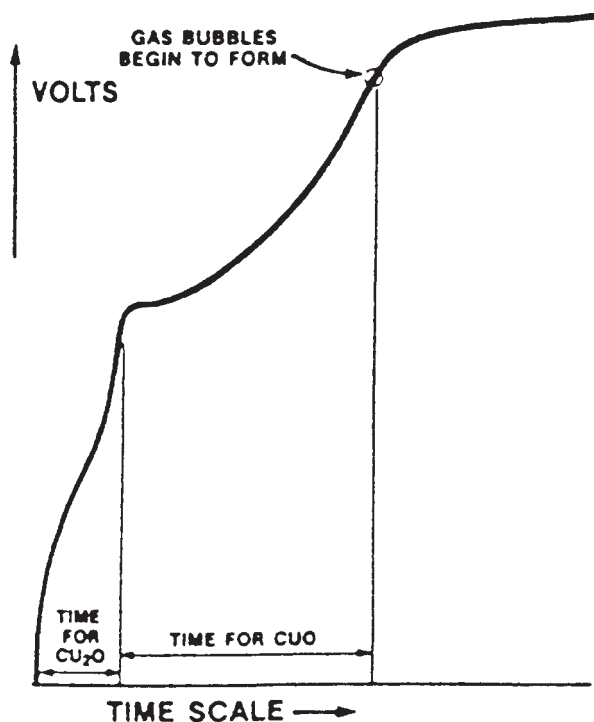

FIG. 2 Typical Voltage-Time Curve for the Reduction of Copper Oxide Films

13.4 *Diameter*—Measure the diameter of the rod with a suitable measuring device, micrometer, caliper or other, reading at least to the nearest 0.001 in. (0.02 mm).

13.5 *Surface Oxide*:

13.5.1 Determine the thickness and type of unreduced oxide films remaining on the surface of rod after cleaning by an electrolytic reduction method. This test is performed by reducing the surface oxide(s) to copper in an electrolytic cell.⁴ As shown by the schematic diagram in Fig. 1, the test sample is made cathodic with respect to an anode, which shall be made from a platinum wire or an equivalent inert electrode. Supply current from a dc power supply or a coulometer. Although 10 milliampere (mA) is a typical value of current, it is best to have equipment capable of operating in the range of 1 to 20 mA. The electrolyte shall be a 0.1M solution of sodium carbonate and shall cover at least 4 in. (101.6 mm) of the test sample. Before testing, clean each rod sample of oil or grease using acetone or an equivalent solvent.

13.5.2 Each of the oxides found on copper, namely cuprous and cupric, are reduced sequentially to copper at different reduction potentials, and the voltages are to be recorded against time during the entire test. When the individual reactions between the oxides and hydrogen ions are complete, gaseous hydrogen is evolved and may be seen visually at the surface of the copper rod sample.

⁴ For a description of a similar, yet alternative standard procedure to determine tarnish films on coupons exposed to environmental tests, see "Monitoring Environmental Tests by Coulometric Reduction of Metallic Control Samples," *Journal of Testing and Evaluation*, 1989, pp. 357–367, ASTM. Also refer to "The Role of Surface Oxide and Its Measurement in the Copper Wire Industry," *Wire Journal*, March 1977, pp. 50–57.

13.5.3 A typical curve of voltage versus time is presented in Fig. 2. Cuprous oxide is reduced initially. When this reaction is complete, reduction of the cupric oxide occurs at a higher voltage.

13.5.4 Calculate thickness of each oxide present as follows:

$$T = \frac{I t M}{S d F n} \quad (1)$$

where:

- T = oxide thickness, cm;
- I = current, A;
- t = time of reaction, s;
- M = molecular weight of the oxide, g;
- S = surface area of immersed sample, cm²;
- d = oxide density (6.0 g/cm³ for Cu₂O and 6.4 g/cm³ for CuO);
- F = Faraday constant, 96 500 C; and
- n = hydrogen equivalent (2).

13.6 *Hydrogen Embrittlement Susceptibility*:

13.6.1 Draw the specimen of oxygen-free copper rod into 0.080-in. (2.03-mm) diameter wire. Then anneal it in an atmosphere containing not less than 10 % of hydrogen for 30 min at 1560 ± 45°F (850 ± 25°C) and cool quickly in the same atmosphere, or without undue exposure to air, quench into water. Make sure that each specimen undergoes the bend test in accordance with 13.6.2.

13.6.2 Lightly clamp the specimen (13.6.1) between jaws with edges having a radius of 0.200 in. (5.1 mm). Then bend it by hand over one edge of the jaws through an angle of 90° and return it to its original position. This constitutes a second bend. Make each successive bend in the opposite direction from the previous bend (see Test Methods B 577).

14. **Significance of Numerical Limits**

14.1 Calculated values shall be rounded to the nearest unit in the last right hand significant digit used in expressing the limiting value in accordance with the rounding-off method in Practice E 29.

15. **Inspection**

15.1 All inspections and tests shall be made at the place of manufacture unless otherwise agreed upon between the manufacturer and the purchaser at the time of purchase. The manufacturer shall afford the inspector representing the purchaser all reasonable facilities to satisfy him that the material being furnished is in accordance with this specification.

16. **Rejection and Rehearing**

16.1 *Rejection*:

16.1.1 Product that fails to conform to the requirements of the product specification may be rejected.

16.1.2 Rejection shall be reported to the manufacturer, or supplier, promptly and in writing.

16.1.3 In case of disagreement or dissatisfaction with the results of the test upon which rejection was based, the manufacturer or supplier may make claim for a rehearing.

16.2 *Rehearing*—As a result of product rejection, the manufacturer or supplier may make claim for retest to be conducted by the manufacturer or supplier and the purchaser. Samples of

the rejected product shall be taken in accordance with the product specification and tested by both parties as directed in the product specification, or alternatively upon agreement by both parties, an independent laboratory may be selected for the tests using the test methods prescribed in the product specification.

17. Certification

17.1 When specified in the contract or purchase order, the purchaser shall be furnished certification that samples representing each lot have been either tested or inspected as directed in this specification and the requirements have been met.

18. Test Report

18.1 When specified in the contract or purchase order, a report of test results shall be furnished.

19. Packaging and Package Marking

19.1 Package size shall be agreed upon between the manufacturer and the purchaser and shall be stated in the order.

19.2 The rod shall be packaged and protected against damage from normal handling and shipping as is consistent with good commercial practice.

19.3 Individual coils without joints and with a net mass greater than 3000 lb (1400 kg) shall be marked or otherwise identified with the following:

19.3.1 Coil production number,

19.3.2 Net weight, and

19.3.3 Manufacturer's name, brand, or trademark.

19.4 Marking for coils other than described in 19.3 shall be agreed upon between the manufacturer and the purchaser.

20. Keywords

20.1 copper redraw rod; electrical conductors; oxygen-free copper; tough-pitch copper

ANNEX

(Mandatory Information)

A1. SAMPLING PLAN

A1.1 This procedure shall be used in case of dispute between the manufacturer and the purchaser.

A1.2 One sample shall be taken from each 200 000-lb (90 000-kg) lot for resistivity, tensile elongation, annealability, surface oxide, embrittlement (bend) test, and chemical analysis.

A1.3 When a cast refinery shape has been chemically analyzed and converted into rod without remelting, further chemical analysis shall not be required.

APPENDIX

(Nonmandatory Information)

X1. EXPLANATORY INFORMATION

NOTE X1.1—Relationships that may be useful in connection with the values of electrical resistivity prescribed in this specification are shown in Table 3. Resistivity units are based on the International Annealed Copper Standards (IACS) adopted by IEC in 1913, which is $1/58 \Omega \cdot \text{mm}^2/\text{m}$ at 20°C for 100 % conductivity. The value of $0.017\,241 \Omega \cdot \text{mm}^2/\text{m}$ and the value of $0.153\,28 \Omega \cdot \text{g m}^2$ at 20°C are, respectively, the international equivalent of volume and weight resistivity of annealed copper equal (to five significant figures) to 100 % conductivity. The latter term means that a copper wire 1 m in length and weighing 1 g would have a resistance of $0.153\,28 \Omega$. This is equivalent to a resistivity value of $875.20 \Omega \cdot \text{lb}/\text{mile}^2$, which signifies the resistance of a copper wire 1 mile in length weighing 1 lb. It is also equivalent, for example, to $1.7241 \mu\Omega/\text{cm}$ of length of a copper bar 1 cm^2 in cross section. A complete discussion of this subject is contained in *NBS Handbook 100*. The use of five significant figures in expressing resistivity does not imply the need for greater accuracy of measurement than that specified in Test Method B 193. The use of five significant figures is required for reasonably accurate reversible conversion from one set of resistivity units to another. The equivalent resistivity

values in Table 3 were derived from the fundamental IEC value ($1/58 \Omega \cdot \text{mm}^2/\text{m}$) computed to seven significant figures and then rounded to five significant figures.

NOTE X1.2—In general, tested values of elongation are reduced with increased speed of the moving head of the testing machine in the tension testing of copper wire and rod. In the case of tests on soft or annealed copper rod, however, the effects of speed of testing are not pronounced. In tests of soft rod made at speeds not greater than 12 in./min (300 mm/min), the values obtained for elongation are not affected to any practical extent (see Test Methods E 8).

NOTE X1.3—Torsion tests are widely used by producers and users. Because of the uncertain correlation with performance, and the subjective aspect of interpretation, these tests should only be used as an indicator of in-house process control. Therefore, no standardized test is recommended.

NOTE X1.4—*Annealability by Hardness Tests*—A rod sample of suitable length shall be cut from each end of a coil lot. The as-received sample shall be cold rolled to a flat section, so that the thickness is equal to 30 % of the original rod diameter. No edge rolling is required. The flattened

copper shall be heated at $527 \pm 2^\circ\text{F}$ ($275 \pm 1^\circ\text{C}$) for 15 min in a constant temperature bath and quenched immediately into water at ambient temperature. Other temperatures and times may be used by special agreement between the manufacturer and purchaser. Hardness shall be measured along the center line of the annealed specimen using the Rockwell F scale, in accordance with Test Method E 18.

NOTE X1.5—Annealability by Torsion (Spiral Elongation)—The spiral elongation test described herewith is used only for testing high conductivity copper that is sampled at the rod stage and does not address the quality of copper wire selected at later stages of commercial processing. Copper wire is initially given a low temperature anneal under tightly controlled conditions, subsequently wound into a spiral (helical configuration) under tensile load, and then stretched axially by a weight of specified mass. The change in length measured after the weight is removed, and the spiral has relaxed, is considered as a measure of softness.

Rod Treatment—A rod sample of suitable length shall be cut from the end of a coil lot, and if necessary, reduced to a diameter of either 0.25 in., $+0.020 - 0.010$ (6.35 mm $+0.50 - 0.25$) or 0.315 ± 0.015 in. (8.00 ± 0.40 mm) by cold drawing. This sample shall either be annealed or not annealed according to the following circumstances:

(a) No annealing treatment will be performed if the copper is processed according to a specific manufacturing schedule.

(b) The sample shall be subjected to an annealing treatment if it is desired to compare samples produced via different manufacturing routes. Under these circumstances, the rod sample shall be annealed under normal atmosphere for 1 h at $700^\circ\text{C} \pm 20$ (1256 to 1328°F) and then quenched into water or a dilute (10 % v/v) sulfuric acid solution at ambient temperature. Copper oxide scale shall be removed in a 10 % v/v volume per volume, sulfuric acid bath and thoroughly washed to remove loose scale or adhering copper dust.

Preparation of Wire for Spiral Elongation Test—The rod sample shall be drawn into a 2.00-mm (0.080 in. ± 0.01) diameter wire in a series of passes, each of which shall reduce the cross-sectional area of the conductor by 20 to 25 %.

Particular care should be taken to avoid excessive heating of the copper during drawing. For example, the wire shall either be allowed to cool for 5 min between passes or quenched to ambient temperature after each pass. In addition, drawing speed should not exceed 60 m/min (200 ft/min), and the drawn wire shall be wound into a coil having a minimum diameter of 200 mm.

After drawing, a coil of the wire shall be formed by winding the conductor around a mandrel having a minimum diameter of 200 mm (7.87 in.). The copper coil shall then be removed from the mandrel, heated for 2 h at $392 \pm 1^\circ\text{F}$ ($200 \pm 0.5^\circ\text{C}$), in a constant temperature bath, and cooled immediately to ambient temperature.

Temperature of the copper wire must be kept uniform and measured quite accurately. Since good temperature control is extremely important, thermocouples should be placed at strategic locations throughout the annealing device. It is recommended that an 8-mm-diameter dummy rod sample be formed into a 200-mm-diameter ring and placed in the constant

temperature bath at the same position normally occupied by the test wire. Using a thermocouple embedded in the rod to a depth equal to the radius, temperature should reach the annealing temperature within a 5-min period.

Test Procedures—A 1400-mm-long test sample is cut from the annealed coil of wire. Using an indelible marking tool, a 1000-mm gage length is marked over the midlength of the copper wire. One end of the test sample is firmly secured to the end of a polished mandrel whose axis is horizontal and which has a diameter of 20 ± 0.01 mm. A 2.240-kg load is suspended from the free end of the wire, thereby inducing a stress of 7 MPa (1000 psi). The wire shall be wound into a spiral by rotating the mandrel at a speed of approximately 50 r/min, taking special care that each turn of the spiral touches the preceding one, that the turns are not pressed into place, that handling is kept to a minimum, and that the wire is wound in the same direction that it was previously coiled.

Although the length between gage marks on the spiral is approximately 28 mm, this distance shall be measured to the nearest 1 mm, and recorded as the initial value “ l_0 .”

The spiral of wire shall then be removed from the mandrel, carefully fastened at one end, and loaded axially at the other (lower) end with the same 2.240-kg weight as that used in the aforementioned coil winding operation.

The weight shall be supported initially with a platform and loaded onto the spiral uniformly and smoothly by either of two methods, namely: (a) lowering the platform supporting the weight or (b) raising the upper end of the spiral at a rate such that the stretching of the spiral does not exceed 20 cm/s.

After 1 min of free suspension, the weight is manually removed in a very careful manner and the elongated spiral is allowed to relax by placing it on a table for an additional period of 1 min. Note that the load is not to be removed by either raising the platform or lowering the upper end of the spiral. The extended length of the spiral between gage marks shall be measured to the nearest 1 mm and called “ l_f .” The spiral elongation value, in millimetres, is calculated as the difference $l_f - l_0$.

This same procedure shall be repeated on two additional spirals of wire from the same coil, and the average value obtained from three separate spirals shall be referred to as the “Spiral Elongation Number.”

NOTE X1.6—Annealability (General)—Although five different basic types of test methods have been reported in the literature for measuring the annealability of wirebar or rod, numerous variations and perturbations exist. For a more thorough description of these tests, refer to the *Journal of Testing and Evaluation*.⁵ Inasmuch as hardness and torsional measurements are frequently used, detailed procedures are contained in Notes X1.4 and X1.5. Softening values for low temperature annealing copper and for other types of copper rods, if requested, shall be decided upon between the producer and the user.

⁵ Joint B-1 and B-2 Task Group, “The Annealability Testing of Copper,” *Journal of Testing and Evaluation*, Vol 1, No. 1, ASTM, 1973.

SUMMARY OF CHANGES

Committee B05 has identified the location of selected changes to this standard since the last issue (B 49 – 92) that may impact the use of this standard.

- (1) The Referenced Documents section has been updated. Significance of Numerical Limits; Test Report, Rejection, and
- (2) The following sections have been added: Terminology; Rehearing; Number of Tests and Retests; Keywords.

ASTM International takes no position respecting the validity of any patent rights asserted in connection with any item mentioned in this standard. Users of this standard are expressly advised that determination of the validity of any such patent rights, and the risk of infringement of such rights, are entirely their own responsibility.

This standard is subject to revision at any time by the responsible technical committee and must be reviewed every five years and if not revised, either reapproved or withdrawn. Your comments are invited either for revision of this standard or for additional standards and should be addressed to ASTM International Headquarters. Your comments will receive careful consideration at a meeting of the responsible technical committee, which you may attend. If you feel that your comments have not received a fair hearing you should make your views known to the ASTM Committee on Standards, at the address shown below.

This standard is copyrighted by ASTM International, 100 Barr Harbor Drive, PO Box C700, West Conshohocken, PA 19428-2959, United States. Individual reprints (single or multiple copies) of this standard may be obtained by contacting ASTM at the above address or at 610-832-9585 (phone), 610-832-9555 (fax), or service@astm.org (e-mail); or through the ASTM website (www.astm.org).