



# Standard Practice for Packaging of Copper and Copper-Alloy Mill-Products for U.S. Government Agencies<sup>1</sup>

This standard is issued under the fixed designation B 900; the number immediately following the designation indicates the year of original adoption or, in the case of revision, the year of last revision. A number in parentheses indicates the year of last reapproval. A superscript epsilon (ε) indicates an editorial change since the last revision or reapproval.

*This standard has been approved for use by agencies of the Department of Defense.*

## 1. Scope

1.1 This practice establishes requirements for packaging, packing, and marking intended to ensure proper and safe storage and transportation of copper and copper-alloy mill-products, both foreign and domestic, for direct shipment to government activities or shipment processed at a military activity or agency. This practice details the materials, methods, containers, and procedures for the preparation for shipment of copper and copper-alloy mill-products. Mill products wherein copper is the basic metal are within the scope of this practice. Commercial packaging establishes the minimum requirements that apply unless Level A or B packing is specified (see 6.1).

1.2 The values given in inch-pound units are regarded as standard. The SI units given in parentheses are for information only.

1.3 *This standard does not purport to address all of the safety concerns, if any, associated with its use. It is the responsibility of the user of this standard to establish appropriate safety and health practices and determine the applicability of regulatory limitations prior to use.*

## 2. Referenced Documents

### 2.1 ASTM Standards:

- B 846 Terminology for Copper and Copper Alloys<sup>2</sup>
- D 143 Method of Testing Small Clear Specimens of Timber<sup>3</sup>
- D 779 Test Method for Water Resistance of Paper, Paperboard, and Other Sheet Materials by the Dry Indicator Method<sup>4</sup>
- D 828 Test Method for Tensile Properties of Paper and Paperboard Using Constant-Rate-of Elongation Apparatus<sup>4</sup>
- D 1974 Practice for Methods of Closing, Sealing, and Reinforcing Fiberboard Boxes<sup>4</sup>

### D 3951 Practice for Commercial Packaging<sup>4</sup>

- D 4444 Test Methods for Use and Calibration of Hand-Held Moisture Meters<sup>3</sup>
- D 5118/D 5118M Practice for Fabrication of Fiberboard Shipping Boxes<sup>4</sup>
- D 5168 Practice for Fabrication and Closure of Triple-Wall Corrugated Fiberboard Containers<sup>4</sup>
- D 5330/D 5330M Specification for Pressure-Sensitive Tape for Packaging, Filament-Reinforced<sup>4</sup>
- D 6251/D 6251M Specification for Natural Wood-Cleated Panelboard Shipping Boxes<sup>4</sup>

### 2.2 ANSI Standard:<sup>5</sup>

- ANSI/ASQC Z1.4 Sampling Procedures and Tables for Inspection by Attributes

### 2.3 Federal Specifications:<sup>6</sup>

- A-A-55057 Panels, Wood/Wood Base: Construction and Decorative
- PPP-B-585 Boxes, Wood, Wirebound
- PPP-B-587 Boxes, Wood, Wirebound Pallet Type
- PPP-B-601 Boxes, Wood, Cleated-Plywood
- PPP-B-621 Boxes, Wood, Nailed and Lock-Corner
- PPP-B-1055 Barrier Material, Waterproofed, Flexible
- PPP-D-705 Drum: Metal Shipping, Steel, (Over 12 and Under 55 Gallon)
- PPP-D-723 Drums, Fiber
- PPP-D-729 Drums: Metal, 55-Gallon (for Shipment of Non-corrosive Material)

### 2.4 Military Standard:<sup>6</sup>

- MIL-STD-129 Marking for Shipment and Storage

### 2.5 Military Publication:<sup>6</sup>

- MIL-HDBK-774 Palletized Unit Loads

## 3. Terminology

3.1 For definitions of terms related to copper and copper alloys, refer to Terminology B 846.

<sup>1</sup> This practice is under the jurisdiction of ASTM Committee B05 on Copper and Copper Alloys and is the direct responsibility of Subcommittee B05.91, Editorial. Current edition approved Oct. 10, 1999. Published February 2000.

<sup>2</sup> *Annual Book of ASTM Standards*, Vol 02.01.

<sup>3</sup> *Annual Book of ASTM Standards*, Vol 04.10

<sup>4</sup> *Annual Book of ASTM Standards*, Vol 15.09.

<sup>5</sup> Available from American National Standards Institute, 11 W. 42nd St., 13th Floor, New York, NY 10036.

<sup>6</sup> Available from Standardization Documents Order Desk, Bldg. 4 Section D, 700 Robbins Ave., Philadelphia, PA 19111-5094, Attn: NPODS.

### 3.2 Definitions of Terms Specific to This Standard:

3.2.1 *deckboard, n*—piece or pieces of lumber fastened at right angles to the stringers or skids of a pallet to form a load-bearing surface.

3.2.2 *gross weight, n*—the bare-item weight and the weight of all packaging and packing materials.

3.2.3 *interleaving, n*—the protective material placed between two adjacent pieces of metal.

3.2.4 *net weight, n*—the bare-item weight.

3.2.5 *nominal, adj*—the rough-sawn, commercial size designation for lumber common to the industry.

3.2.6 *packing; Level A*—the protection required to meet the most severe worldwide shipment, handling, and storage conditions. A Level A package must be capable of protecting material from effects of direct exposure to extremes of climate, terrain, and operational transportation environments.

3.2.7 *packing; Level B*—the protection required to meet moderate worldwide shipment, handling, and storage conditions. A Level B package must be capable of protecting material not directly exposed to extremes of climate, terrain, and operational transportation environments.

3.2.8 *packaging; commercial*—although not specifically defined by any government regulation or instruction, commercial packaging (preservation and packing) is understood to be those practices by manufacturers and contractors to protect and identify material and items packaged for retail and wholesale distribution purposes. Practice D 3951 provides guidance in the application of commercial packaging.

NOTE 1—It has been determined by joint DoD instructions that commercial, also in some areas addressed as industrial packaging, should only be used or specified when such packaging is known to satisfy the DoD needs. Such use should be determined before a contract for supplies is awarded or within the life cycle of the contract when substantial savings to the government may result. Commercial (industrial) packaging should not be specified where multiple shipments and handlings are anticipated or desired.

3.2.9 *skid, n*—one of a pair or series of parallel wood runners affixed to the underside of boxes, crates, or an item allowing entry of truck forks, or to facilitate sliding.

3.2.10 *sound woods, n*—wood free of any form of decay, incipient or advanced, and from insert holes.

3.2.11 *stringer, n*—a wooden member fastened at right angles to the load-bearing members of a pallet or the deckboard of a platform.

3.2.12 *sulfate paper, n*—wood-pulp paper made by the sulfate process.

## 4. Significance and Use

4.1 This practice is applicable to packaging of copper-alloy mill-products for shipment to agencies of the U.S. government.

4.2 It covers packaging of rod, bar, shapes, plate, sheet, strip, foil, wire, flat wire, rolled bar, forgings, pipe, and tube products.

## 5. Classification

5.1 Shipping containers, for Levels A and B packing (see 7.6 and 7.8), having common characteristics are as follows:

5.1.1 *Category 1*—Boxes, nailed wood, wire-bound wood, wood-cleated plywood, and wood cleated, veneer, paper overlaid (see 7.6.1).

5.1.2 *Category 2*—Fiber and metal drums (see 7.6.2).

5.1.3 *Category 3*—Pallets and pallet boxes (see 7.6.3).

5.1.4 *Category 4*—Skidded lifts (see 7.6.4).

5.1.5 *Category 5*—Hand bundles (see 7.6.5).

5.1.6 *Category 6*—Secured lifts (without skids) (master bundles) (see 7.6.6).

5.1.7 *Category 7*—Reels and spools (see 7.6.7).

5.1.8 *Category 8*—Fiberboard boxes (see 7.6.8).

5.1.9 *Category 9*—Special containers (see 7.6.9).

## 6. Ordering Information

6.1 Orders for products shall specify the following packaging information:

6.1.1 ASTM designation and year of issue.

6.1.2 Fiberboard box, if other than Class 1 (see 7.6.8).

6.1.3 Level of packaging and level of packing if other than commercial (see 7.4 and 7.6.9.1).

6.1.4 Maximum gross weight of container (see 7.6.1.6-7.6.1.8, 7.6.3 and 7.6.4).

6.1.5 When palletized drums are required (see 7.8.2.7).

6.1.6 When bare welding rod in wire form is required in fiber drums (see 7.8.2.7).

6.1.7 When cores fitted with slinger ring attachment are required for shafting (see 7.8.2.7).

6.1.8 When coiled wire is required in lighter or heavier net weight (see 7.8.2.7).

6.1.9 When saddles are required (see 7.8.3.1).

6.1.10 Special marking required (see 7.9).

## 7. Detailed Requirements

7.1 *Options*—Unless otherwise specified, packaging and packing requirements selection shall be at the option of the contractor.

7.2 *Packaging and Packing Materials*—Materials not covered by applicable specifications or not specifically described herein shall be of the best commercial quality and suitable for the purpose intended.

7.2.1 *Packaging*—The use of packaging materials shall be in accordance with 7.8.

7.3 *Level A:*

7.3.1 *Waterproof Barrier Materials*—The material shall consist of 100 % sulfate paper suitably coated or laminated to meet the following tensile-strength requirement when tested in accordance with Test Method D 828 and the following water-resistance requirement when tested in accordance with Test Method D 779. If an asphalt laminate [base weight 30 lbs (13.6 kg) minimum] is used, the paper shall have a minimum base weight of 30 lbs per 500 sheets 24 by 36 in. (609.6 by 914.4 mm) (30-30-30-minimum).

|  |                  |
|--|------------------|
| Tensile strength per inch width (weaker direction) | 15 lbs (16.8 kg) |
| Water resistance (dry indicator method)            | 10 h             |

7.3.2 Alternatively, waterproof-barrier materials in accordance with Specification PPP-B-1055 may be used at the contractor's option. All wrapping material in contact with bare metal surfaces shall be within the pH range from 5.0 to 10.0.

7.3.3 *Interleaving Paper*—Interleaving paper shall be anti-tarnishing, noncorrosive, uncreped paper of 10-lbs (4.54-kg) minimum base weight.

7.3.4 *Unit Containers*—Fiberboard boxes and closure methods used for packaging wire on spools, wire and tube in coils, or similar products shall be in accordance with Practices D 5118 and D 1974. Where specific container designs are not described by the applicable specification, the manufacturer’s commercial practice shall apply.

7.4 *Commercial*—Unless Level A or B packing is specified (see 6.1), the following shall apply.

7.4.1 Packaging material(s) shall be sufficient to afford adequate protection against physical damage during shipment from the supply source to the first receiving activity for immediate use. This level may be in accordance with Practice D 3951 when such meets the requirements of this level.

7.5 *Packing (Levels A and B)*:

7.5.1 *Wood*—Requirements for wood for boxes, pallets, reels, and similar items with regard to species, quality, and dimensions shall be in accordance with Specification PPP-B-621 except as modified in 7.5.1.2 and Tables 1-3.

7.5.1.1 *Seasoning*—The wood shall be seasoned to a moisture content not more than 18 % nor less than 12 %. At the time of inspection of containers, the moisture content of the wood shall not be less than 8 %. Wood for pallets shall be seasoned to a moisture content not more than 22 % for deck boards and 26 % for stringers.

7.5.1.2 *Plywood*—Plywood for boxes shall be in accordance with Type I or II, Class 2 of Specification A-A-55057 for Level A packing, and Type III, Class 1 of Specification A-A-55057 for Label B packing.

7.6 *Container Construction Packing and Securing Methods (Levels A and B)*:

7.6.1 *Category 1 Boxes*:

7.6.1.1 *Nailed Wood Boxes (All Groups of Wood)*—The construction and style of nailed wood boxes shall be in accordance with Figs. 1-6 and Tables 1-4. Side, top, and bottom sections 9½ in. (241.3 mm) or less in width shall be made of one piece, whenever possible. Spliced boards, whenever necessary, on nailed wood boxes are permissible. The boards shall be butted and the splicing board shall extend on

each side of the joint at least three times the width of the board being spliced. The splicing board shall equal the width and thickness of the boards being spliced. Nails shall be clinched.

7.6.1.2 *Skid (Runners)*—Except as specified herein, boxes having a gross weight exceeding 600 lbs (272 kg) shall be modified by the addition of nominal 2- by 4-in. (50.8- by 101.6-mm) skids positioned flatwise across the width of the box and located approximately 4 in. (101.6 mm) from the ends of the box. In attaching skids, nailing shall be through the bottom boards and into the skids. When longitudinal, as well as, girthwise straps are required, the skids shall be notched to permit passage of the straps between the skids and the bottom of the box. Skids are not required for boxes shipped on pallets, boxes in a skidded master shipping unit, or boxes 7 ft (2.13 m) or over in length.

7.6.1.3 *Thickness of Lumber*—The thickness of lumber for nailed wood boxes shall be in accordance with Tables 1-3.

7.6.1.4 *Nails*—The nails for nailed wood boxes shall be in accordance with Table 4.

7.6.1.5 *Strapping*—Nailed wood boxes shall be strapped with flat steel strap or round wire having a breaking strength equivalent to that of the flat steel strap. Strap placement shall be in accordance with Figs. 1-6, as applicable.

7.6.1.6 *Wirebound Boxes*—Wirebound boxes shall conform to Specification PPP-B-585, Class 3 use for Level A packing and Class 1 or 2 use for Level B packing. Unless otherwise specified (see 6.1), the gross weight of wirebound boxes shall not exceed the requirements of the box specification.

7.6.1.7 *Wood, Cleated-Plywood Boxes*—Wood cleated-plywood boxes shall be in accordance with Specification PPP-B-601, overseas type for Level A packing and domestic type for Level B packing. Unless otherwise specified (see 6.1), the gross weight shall not exceed, the weight limitations of the box specification.

7.6.1.8 *Wood, Cleated, Veneer, Paper-Overlaid Boxes*—Wood, cleated, veneer, paper-overlaid boxes shall conform to Specification D 6251/D 6251M Class 2 for Level A packing and Class 1 for Level B packing. Unless otherwise specified (see 6.1), the gross weight shall not exceed the weight limitations of the box specification.

**TABLE 1 Nailed Wood Boxes for Straight Lengths of Bar, Rod, Shafting, Shapes, Flat Wire, and Tubular Products**

| Weight of Content, lbs<br>(kg) | Box Styles<br>(See Figs. 1-6) | Minimum Sides<br>Thickness, in.<br>(mm) | Minimum Top<br>and Bottom<br>Thickness,<br>in. (mm) | Ends  |   | End Cleats <sup>A</sup>       |                                   | Battens <sup>A</sup>          |                                   |
|--------------------------------|-------------------------------|---|---|---|---|-------------------------------|-----------------------------------|-------------------------------|-----------------------------------|
|                                |                               |   |   | Styles 1<br>and 1A <sup>B</sup>                           | Styles 2, 4, 7,<br>and 8 <sup>C</sup>   | Styles 2, 4, 7, and 8         |                                   | Styles 1A, 7, and 8           |                                   |
|                                |                               |   |   | Minimum 1 or<br>2-Ply Thickness,<br>in. (mm) <sup>D</sup> | Minimum 1-Ply<br>Thickness, in.<br>(mm) | Minimum<br>Width, in.<br>(mm) | Minimum<br>Thickness, in.<br>(mm) | Minimum<br>Width, in.<br>(mm) | Minimum<br>Thickness,<br>in. (mm) |
| Up to 280 (127)                | 1, 2, and 4                   | 5/8(15.8)                               | 1/2 (12.7)  | 1 1/16(27.0)  | 5/8(15.8)                               | 2 1/2(63.5)                   | 5/8(15.8)                         | ...                           | ...                               |
| 281 to 560<br>(128 to 254)     | 1, 2, and 4                   | 5/8(15.8)                               | 5/8 (15.8)  | 1 1/16(27.0)  | 5/8(15.8)                               | 2 1/2(63.5)                   | 5/8(15.8)                         | ...                           | ...                               |
| 561 to 1120<br>(255 to 508)    | 1 to 8                        | 3/4(19.1)                               | 5/8 (15.8)  | 1 1/2(38.1)   | 1 1/16(27.0)                            | 2 3/4(69.9)                   | 5/8(15.8)                         | 2 3/4 (69.9)                  | 3/4(19.1)                         |
| 1121 to 2240<br>(509 to 1016)  | 1 to 8                        | 1 1/16(27.0)                            | 3/4(19.1)   | 1/2 (38.1)  | 1 1/16(27.0)                            | 2 3/4(69.9)                   | 1 1/16(27)                        | 2 3/4(69.9)                   | 3/4 (19.1)                        |

<sup>A</sup>Nails used for end cleats shall pass through the ends and be clinched to not less than 1/8 (3.175 mm). Nailing and clinching of battens shall be in such a manner as to prevent damage by protruding heads or points to the contents of the box.

<sup>B</sup>Ends of boxes having a weight content exceeding 2000 lbs (907 (kg) or ends of boxes exceeding 12 in. (305 mm) in depth shall be two-ply laminates of equal thickness with the grain reversed.

<sup>C</sup>Styles 2, 4, 7, and 8 boxes shall not be required if the depth of the box is 10 in. (254 mm) or less.

<sup>D</sup>Combined thickness of two-ply end; grain of separate piles reversed.

**TABLE 2 Nailed Wood Boxes for Flat Straight Lengths of Plate, Sheet, and a Strip**

| Weight of Content, lbs (kg)                     | Box Styles (See Figs. 1-6) | Minimum Sides Thickness, in. (mm) | Minimum Top and Bottom Thickness, in. (mm) | Ends  |                                    | End Cleats                         |                             | Battens                 |                             |  |
|---|----------------------------|-----------------------------------|--|---|------------------------------------|------------------------------------|-----------------------------|-------------------------|-----------------------------|--|
|   |                            |                                   |  | Styles 1 and 1A <sup>A</sup>                        | Styles 2, 4, 7, and 8 <sup>B</sup> | Styles 2, 4, 7, and 8 <sup>C</sup> | Styles 1A, 7, and 8         |                         |                             |  |
|   |                            |                                   |  | Minimum 1 or 2-Ply Thickness, in. (mm) <sup>D</sup> | Minimum 1-Ply Thickness, in. (mm)  | Minimum Width, in. (mm)            | Minimum Thickness, in. (mm) | Minimum Width, in. (mm) | Minimum Thickness, in. (mm) |  |
| Up to 280 (127)                                 | 1, 2, and 4                | 5/8(15.8)                         | 1/2(12.7)                                  | 1 1/16(27.0)  | ...                                | ...                                | ...                         | ...                     | ...                         |  |
| 281 to 560 (128 to 254)                         | 1, 2, and 4                | 5/8(15.8)                         | 5/8 (15.8)                                 | 1 1/16(27.0)  | 5/8(15.8)                          | 2 1/2(63.5)                        | 5/8(15.8)                   | ...                     | ...                         |  |
| 561 to 1120 (255 to 508)                        | 1 to 8                     | 1 1/16(27.0)                      | 5/8(15.8)                                  | 1 1/2 (38.1)  | 1 1/16(27.0)                       | 2 3/4(69.9)                        | 3/4(19.1)                   | 2 3/4(69.9)             | 3/4(19.1)                   |  |
| 1121 to 2240 (509 to 1016)                      | 1 to 8                     | 1 1/16(27.0)                      | 5/8(15.8)                                  | 1 1/2 (38.1)  | 1 1/16(27.0)                       | 2 3/4(69.9)                        | 1 1/16(27.0)                | 2 3/4(69.9)             | 1 1/16 (27.0)               |  |
| 2241 to 6000 (1017 to 2722)                     | 1 to 8                     | 1 1/2(38.1)                       | 1 1/16 (27.0)                              | 2 (51)  | 1 1/16(27.0)                       | 2 3/4 (69.9)                       | 1 1/16(27.0)                | 2 3/4(69.9)             | 1 1/16(27.0)                |  |
| Boxes for Products Over 4 ft (1.22 m) in Length |                            |                                   |  |   |                                    |                                    |                             |                         |                             |  |
| Up to 280 (127)                                 | 1 or 1A                    | 5/8(15.8)                         | 1/2(12.7)                                  | 1 1/16(27.0)  | ...                                | ...                                | ...                         | 2 1/2(63.5)             | 5/8(15.8)                   |  |
| 281 to 560 (128 to 254)                         | 1 or 1A                    | 1 1/16(27.0)                      | 5/8(15.8)                                  | 1 1/16 (27.0)                                       | ...                                | ...                                | ...                         | 2 1/2 (63.5)            | 5/8(15.8)                   |  |
| 561 to 1120 (255 to 508)                        | 1 or 1A                    | 1 1/16(27.0)                      | 5/8(15.8)                                  | 1 1/2 (38.1)  | ...                                | ...                                | ...                         | 2 3/4 (69.9)            | 3/4(19.1)                   |  |
| 1121 to 2240 (509 to 1016)                      | 1 to 8                     | 1 1/2(38.1)                       | 3/4(19.1)                                  | 1 1/2 (38.1)  | 1 1/16(27.0)                       | 2 3/4(69.9)                        | 1 1/16(27.0)                | 2 3/4(69.9)             | 1 1/16 (27.0)               |  |
| 2241 to 6000 (1017 to 2722)                     | 1 to 8                     | 1 1/2(38.1)                       | 1 1/16(27.0)                               | 2 (51)  | 1 1/16(27.0)                       | 2 3/4(69.9)                        | 1 1/16 (27.0)               | 2 3/4(69.9)             | 1 1/16(27.0)                |  |

<sup>A</sup>Ends of boxes having a weight content exceeding 2000 lbs (907 kg) or ends of boxes exceeding 12 in. (305 mm) in depth shall be two-ply laminates of equal thickness with the grain reversed.

<sup>B</sup>Styles 2, 4, 7, and 8 boxes shall not be required if the depth of the box is 10 in. (254 mm) or less.

<sup>C</sup>Nails used for end cleats shall pass through the ends and be clinched to not less than 1/8 (3.175 mm). Nailing and clinching of battens shall be in such a manner as to prevent damage by protruding heads or points to the contents of the box.

<sup>D</sup>Combined thickness of two-ply end; grain of separate piles reversed.

**TABLE 3 Nailed Wood Boxes for Wire (Round or Flat) on Spools or in Coils, Tubes in Coils, Circles and Disks, Sheet and Strip in Rolls, Forgings, or Similar Items**

| Weight of Content, lbs (kg) | Box Styles (See Figs. 1-6) | Minimum Sides Thickness, in. (mm) | Minimum Top and Bottom Thickness, in. (mm) | Ends  |                                    | End Cleats                         |                             | Battens                 |                             |
|-----------------------------|----------------------------|-----------------------------------|--|---|------------------------------------|------------------------------------|-----------------------------|-------------------------|-----------------------------|
|                             |                            |                                   |  | Styles 1 and 1A <sup>A</sup>                        | Styles 2, 4, 7, and 8 <sup>B</sup> | Styles 2, 4, 7, and 8 <sup>C</sup> | Styles 1A, 7, and 8         |                         |                             |
|                             |                            |                                   |  | Minimum 1 or 2-Ply Thickness, in. (mm) <sup>D</sup> | Minimum 1-Ply Thickness, in. (mm)  | Minimum Width, in. (mm)            | Minimum Thickness, in. (mm) | Minimum Width, in. (mm) | Minimum Thickness, in. (mm) |
| Up to 280 (127)             | 1, 2, and 4                | 5/8(15.8)                         | 1/2(12.7)                                  | 1 1/16(27.0)  | 5/8(15.8)                          | 2 1/2 (63.5)                       | 5/8(15.8)                   | ...                     | ...                         |
| 281 to 560 (128 to 254)     | 1, 2, and 4                | 5/8(15.8)                         | 5/8 (15.8)                                 | 1 1/16(27.0)  | 5/8(15.8)                          | 2 1/2(63.5)                        | 5/8(15.8)                   | ...                     | ...                         |
| 561 to 1120 (255 to 508)    | 1 to 8                     | 3/4(19.1)                         | 5/8(15.8)                                  | 1 1/16(27.0)  | 3/4(19.1)                          | 2 3/4 (69.9)                       | 3/4(19.1)                   | 2 3/4(69.9)             | 3/4(19.1)                   |
| 1121 to 2240 (509 to 1016)  | 1 to 8                     | 3/4(19.1)                         | 5/8(15.8)                                  | 1 1/16(27.0)  | 3/4(19.1)                          | 2 3/4 (69.9)                       | 3/4(19.1)                   | 2 3/4(69.9)             | 3/4(19.1)                   |
| 2241 to 6000 (1017 to 2722) | 2 to 8                     | 1 1/2(38.1)                       | 1 1/16(27.0)                               | ...   | 1 1/16(27.0)                       | 2 3/4(69.9)                        | 1 1/16 (27.0)               | 2 3/4(69.9)             | 3/4(19.1)                   |

<sup>A</sup>Ends of boxes having a weight content exceeding 2000 lbs (907 kg) or ends of boxes exceeding 12 in. (305 mm) in depth shall be two-ply laminates of equal thickness with the grain reversed.

<sup>B</sup>Styles 2, 4, 7, and 8 boxes shall not be required if the depth of the box is 10 in. (254 mm) or less.

<sup>C</sup>Nails used for end cleats shall pass through the ends and be clinched to not less than 1/8 (3.175 mm). Nailing and clinching of battens shall be in such a manner as to prevent damage by protruding heads or points to the contents of the box.

<sup>D</sup>Combined thickness of two-ply end; grain of separate piles reversed.

**7.6.1.9 Closure and Strapping**—Closure and strapping requirements for wood cleated-plywood boxes and wood, cleated, veneer, paper-overlaid boxes shall be in accordance with the appendix to the applicable box specification (D 6251/ D 6251M, PPP-B-585, or PPP-B-601 as required). (See Table 5.)

**7.6.2 Category 2, Drums:**

**7.6.2.1 Fiber Drums**—Fiber drums shall be in accordance with Specification PPP-D-723 Type II, Grade A for Level A packing and Type I, Grade A (class optional) for Level B packing.

**7.6.2.2 Metal Drums**—Metal drums shall be in accordance with Specification PPP-D-705 or PPP-D-729 at the option of the contractor.

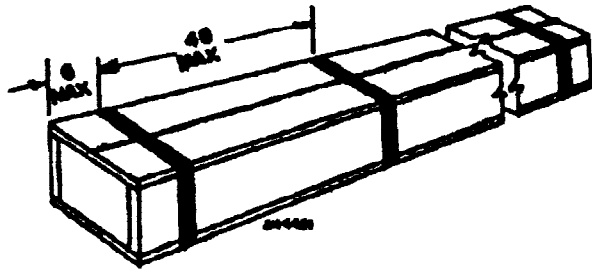

NOTE 1—All dimensions are in inches.  
FIG. 1 Style 1 Box

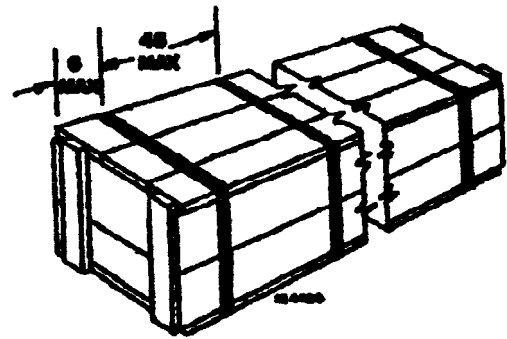

NOTE 1—All dimensions are in inches.  
FIG. 4 Style 4 Box

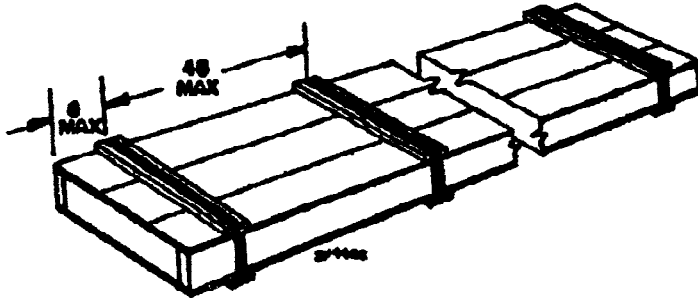

NOTE 1—All dimensions are in inches.  
FIG. 2 Style 1A Box (Batten Reinforced Top and Bottom)

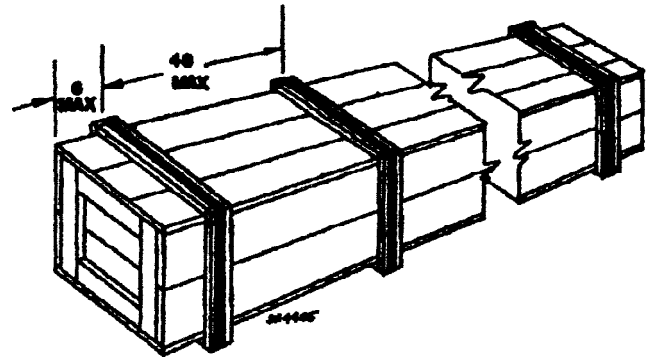

NOTE 1—All dimensions are in inches.  
FIG. 5 Style 7 Box (Batten Reinforced)

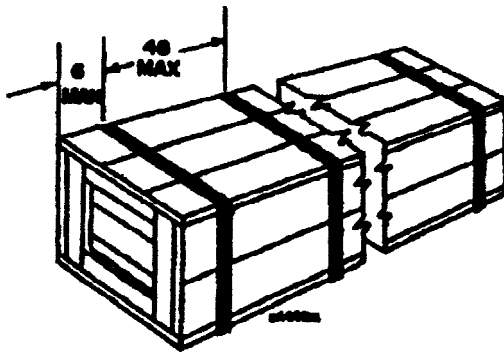

NOTE 1—All dimensions are in inches.  
FIG. 3 Style 2 Box

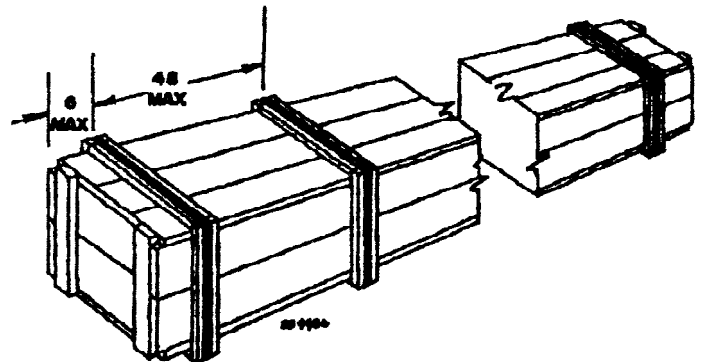

NOTE 1—All dimensions are in inches.  
FIG. 6 Style 8 Box (Batten Reinforced)

7.6.3 *Category 3 Pallets and Pallet Boxes*—Unless otherwise specified (see 8.1), the gross weight shall not exceed 6000 lbs (2722 kg).

7.6.3.1 *Pallets*—Pallets for Level A or B shipments shall be the expendable type and constructed as follows:

(1) *Lumber*—All groups of wood (see 7.5.1). Surfaced deck boards of fairly uniform width and spacing.

(2) *Thickness:*

*Deckboards*—Groups I and II woods, 1 in. (25.4 mm) minimum. Groups III and IV woods ¾ in. (19.1 mm) minimum.

*Stringers*—All wood groups, 1½ by 3½ in. (38.1 by 88.9 mm).

(3) *Moisture Content:*

Deck boards, 22 % maximum.

Stringers, 26 % maximum.

(4) *Design:*

Types—Single-face, wing-type, two-way entry (see Fig. 7).

Single-face, flush stringer, two-way entry (see Fig. 8).

Single-face, post-construction, four-way entry (see Fig. 9).

Stringers—Three stringers on pallet widths 30 in. (762 mm) and over.

7.6.3.2 *Pallet Boxes*—Wire-bound or nailed wood boxes with a pallet or skid-type base shall be used (see Figs. 10 and 11). Wire-bound pallet boxes shall be Type I, Class 1 or 2, or Type III, Class 3 or 4 of PPP-B-587, depending on the need for two-way or four-way entry bases and on the weight of contents to be packed. Nailed-wood pallet boxes shall be constructed of ¾-in. (19.1-mm) minimum thickness of material; Group I, II,

TABLE 4 Nails

| For Nailing Side to End     |               | For Nailing Top and Bottom to Sides and Ends |                                       |              |    |     |    |    |
|-----------------------------|---------------|--|---------------------------------------|--------------|----|-----|----|----|
| Thickness of Side, in. (mm) | Nail, Minimum | Inside Depth of Side or End, in. (mm)        | Thickness of Top and Bottom, in. (mm) |              |    |     |    |    |
|                             |               |  | Nail, Minimum                         |              |    |     |    |    |
| 5/8(15.8)                   | 6d            | up to 3/4 (19.1), incl                       | 1/2 5/8(15.8)                         | 19 3/8(27.0) | 2d | 3d  | 3d | 4d |
|                             |               |  | (12.7)                                |              |    |     |    |    |
| 1 1/8(27.0)                 | 12d           | over 3/4 to 1 1/2 (19.2 to 38.1), incl       | 3d                                    | 3d           | 4d | 5d  |    |    |
|                             |               |  |                                       |              |    |     |    |    |
| 1 1/2(38.1)                 | 16d           | over 1 1/2 to 3 (38.2 to 76.2), incl         | 4d                                    | 4d           | 5d | 7d  |    |    |
|                             |               |  | 5d                                    | 6d           | 7d | 10d |    |    |

TABLE 5 Minimum Strap Sizes

| Weight of Box Contents, lbs (kg) | Width by Thickness Size Strap, in. (mm) |
|----------------------------------|---|
| Up to 280 (127)                  | 1/2 by 0.020 (12.7 by 0.51)             |
| 281 to 560 (128 to 254)          | 5/8 by 0.020 (15.8 by 0.51)             |
| 561 to 1120 (255 to 508)         | 3/4 by 0.023 (19.1 by 0.58)             |
| 1121 to 2240 (509 to 1016)       | 3/4 by 0.023 (19.1 by 0.58)             |
| 2241 to 6000 (1017 to 2722)      | 3/4 by 0.035 (19.1 by 0.89)             |

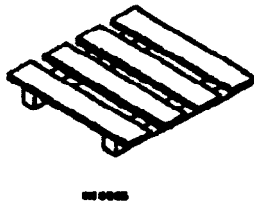

NOTE 1—All dimensions are in inches.  
FIG. 7 Single Face Wing Type

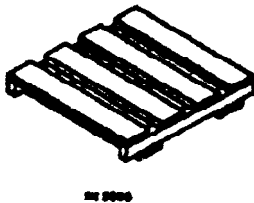

NOTE 1—All dimensions are in inches.  
FIG. 8 Single Face (with Bottom Cleats)

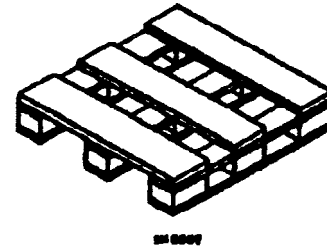

NOTE 1—All dimensions are in inches.  
FIG. 9 Four-Way Entry  
TYPICAL PALLET CONSTRUCTION

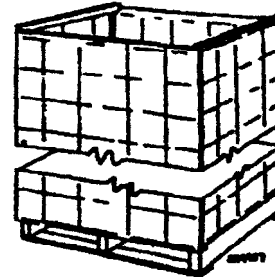

NOTE 1—All dimensions are in inches.  
FIG. 10 Pallet Box (Wire-Bound Construction)

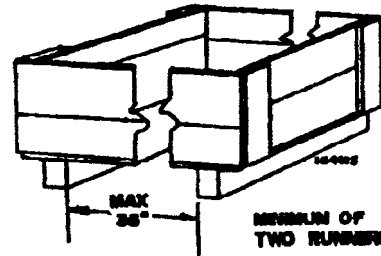

NOTE 1—All dimensions are in inches.  
FIG. 11 Pallet Box (Nailed Wood Construction)

III, or IV woods. Stringers shall be minimum 3 1/2 by 3 1/2 in. (88.9 by 88.9 mm) as shown on Fig. 11. If the width of the box exceeds 40 in. (1016 mm), a third stringer shall be added.

7.6.4 *Category 4, Skidded Lifts*—A skidded lift is a means of packing heavy products by securing skids (runners) to the product itself, either crosswise or lengthwise, with flat steel straps or equivalent strength round wire. Unless otherwise specified (see 6.1), the gross weight of 6000 lbs (2722 kg) is permissible for skidded lifts.

7.6.4.1 *Skids (Runners)*—Skids shall be sound lumber of not less than 3-in. (76.2-mm) nominal width by 4-in. (101.6-mm) nominal height. Skid ends shall be beveled. The length of the skids shall be the full dimension of the unit along the direction in which they are used. At least two skids shall be used.

7.6.4.2 *Strapping*—Flat-steel straps or equivalent strength round-wires shall be stapled to the skid ends. Flat steel straps

shall be a minimum of 3/4 by 0.025 in. (19.1 by 0.635 mm). Straps shall not be in direct contact with the product.

7.6.4.3 *Protectors*—Metal protectors, cushioning packs, or sheets of corrugated fiberboard shall be used between the straps and the product.

7.6.5 *Category 5, Hand Bundles*—Hand bundles of straight- or flat-length products shall be tied with rope, wire, flat steel straps, or tape in accordance with Specification D 5330. At least two ties shall be used. Spacing between ties shall not exceed 6 ft (1.83 m). The ties shall be approximately 12 in. (304.8 mm) from each end except where short lengths of the products will not permit. The weight of hand bundles shall not exceed 200 lbs (91 kg).

7.6.5.1 Hand bundles of coiled wire and similar products shall have at least three ties.

7.6.6 *Category 6, Secured Lifts Without Skids (Master Bundles)*—Secured lifts shall be strapped in accordance with Table 6.

7.6.6.1 *Protectors*—Metal protectors, fibrous pads, or corrugated fiberboard shall be used under ties of sheet, plate, and

**TABLE 6 Minimum Size of Girthwise Straps for Secured Lifts**

| Length of Lift, ft (m)   | Minimum Number<br>of Straps <sup>A</sup> | Weight of Secured Lift, lbs (kg)                         |                             |                             |                                |
|--------------------------|--|--|-----------------------------|-----------------------------|--------------------------------|
|                          |  | 200 to 560 (90.7 to 254)                                 | 561 to 1120 (255 to 508)    | 1121 to 2240 (509 to 1016)  | 2241 to 6000 (1017 to 2722)    |
|                          |  | Size of Straps <sup>B</sup> Width by Thickness, in. (mm) |                             |                             |                                |
| Up to 10 (3.05)          | 3  | 5/8 by 0.020 (15.8 by 0.51)                              | 3/4 by 0.023 (19.1 by 0.58) | 3/4 by 0.028 (19.1 by 0.71) | 1 1/4 by 0.035 (31.75 by 0.89) |
| 11 to 21 (3.06 to 6.40)  | 4  | 5/8 by 0.020 (15.8 by 0.51)                              | 3/4 by 0.023 (19.1 by 0.58) | 3/4 by 0.028 (19.1 by 0.71) | 3/4 by 0.035 (19.1 by 0.89)    |
| 22 to 30 (6.70 to 9.14)  | 5  | 1/2 by 0.020 (12.7 by 0.51)                              | 3/4 by 0.020 (19.1 by 0.51) | 3/4 by 0.028 (10.1 by 0.71) | 3/4 by 0.035 (19.1 by 0.89)    |
| 31 to 40 (9.44 to 12.19) | 6  | 1/2 by 0.020 (12.7 by 0.51)                              | 3/4 by 0.020 (19.1 by 0.51) | 3/4 by 0.028 (19.1 by 0.71) | 3/4 by 0.035 (19.1 by 0.89)    |
| Over 40 (12.20)          | <sup>C</sup>                             | 1/2 by 0.020 (12.7 by 0.51)                              | 5/8 by 0.020 (15.8 by 0.51) | 3/4 by 0.023 (19.1 by 0.71) | 3/4 by 0.035 (19.1 by 0.89)    |

<sup>A</sup>End ties shall be secured approximately 12 in. (305 mm) from each end; additional ties shall be evenly spaced between the end ties.

<sup>B</sup>Equivalent strength galvanized round- or high-tensile wire may be substituted.

<sup>C</sup>For lengths over 40 ft (12.19 m), the maximum distance between straps shall not exceed 7 ft (2.13 m).

coiled products where it is essential for protection of finish, shape, or the wrapping material under the strapping.

7.6.7 *Category 7, Reels and Spools*—Reels and spools shall be of commercial design and construction.

7.6.8 *Category 8, Fiberboard Boxes*—Unless specified when ordered, the contractor shall have the option of having fiberboard boxes and their closure conform to either Practice D 5168 or both Practices D 5118 and D 1974. Class 2 fiberboard boxes shall be for Level A packing and unless otherwise specified (see 6.1), Class 1 fiberboard boxes shall be for Level B packing.

7.6.8.1 *Closure, Sealing, and Reinforcing*—Fiberboard-box closure, sealing, and reinforcing shall be in accordance with the appendix to the applicable box standard (Practices D 5118 and D 1974 or Practice D 5168).

7.6.9 *Category 9, Special Containers*—Containers, other than those listed in this practice, of special design or construction may be used subject to review by the command or agency concerned.

7.6.9.1 *Commercial*—Unless Level A or B packing is specified (see 6.1), the following container construction and securing methods shall apply.

7.6.9.2 Container construction and securing methods shall be sufficient to afford adequate protection against physical or mechanical damage during shipment from the supply source to the first receiving activity for immediate use. Container construction and securing methods shall be in accordance with Practice D 3951.

7.7 *Box—Style Details* (see Figs. 1-6).

7.7.1 *Styles 1 and 1A (No Cleats)*:

7.7.1.1 At the ends, the grain of the wood shall run in the direction of the greatest dimensions.

7.7.1.2 Styles 1 and 1A boxes shall be limited to a height of 10 in. (254 mm).

7.7.2 *Styles 2 and 7 (Four Plain Cleats Each End)*:

7.7.2.1 The ends of the cleats that run across the grain of the ends shall be 1/8 in. (3.18 mm) from the inside surface of the top and bottom.

7.7.2.2 The sides, top, and bottom shall be flush with the outside surface of the cleats.

7.7.3 *Styles 4 and 8 (Two Plain Cleats Each End)*:

7.7.3.1 The ends of the cleats that run across the grain of the ends shall be 1/8 in. (3.18 mm) from the inside surface of the top and bottom.

7.7.3.2 The sides shall be flush with the outside surface of the cleats.

7.8 *Commodity Packing Details (Levels A and B)*:

7.8.1 *Straight Lengths of Bar, Rod, Shapes, Flat Wire, and Tubular Products*:

7.8.1.1 *Level A*—The products shall be separated by size, composition, and temper and packed in accordance with specified in 7.8.1.2 or 7.8.1.3, as applicable.

7.8.1.2 Rod, bar, and shapes under 3/8 in. (9.53 mm) in diameter or thickness, flat wire, and tubular products shall be packed in nailed-wood boxes in accordance with 7.6.1.2. Lengths up to 60 in. (1524 mm), inclusive, may also be packed in wire-bound boxes, wood-cleated plywood boxes, or pallet boxes in accordance with 7.6.1.6, 7.6.1.7, and 7.6.3.2, respectively. Small boxes, whenever practicable, shall be palletized or tied onto a skidded master lift.

7.8.1.3 Rod, bar, and shapes, under 3/8 in. (9.53 mm) and area in diameter or thickness, shall be packed in Category 1, 4, or 6 containers in accordance with 7.6.1, 7.6.4, and 7.6.6, respectively. The gross weight of the container shall not exceed 6000 lbs (2722 kg).

7.8.1.4 *Level B*—Packing shall be in accordance with Level A as specified in 7.8.1.1 or in Category 4, 5, or 6 containers in accordance with 7.6.4, 7.6.5, and 7.6.6, respectively.

7.8.2 *Welding Rod in Bare-Rod or Bare-Wire Form in Straight Lengths, Coils, or on Spools*:

7.8.2.1 *Levels A and B*—The product shall be separated by size, composition, and temper and packed in accordance with 7.8.2.2, 7.8.2.6, or 7.8.2.8.

7.8.2.2 *Straight Lengths*—Nominal Straight lengths 36 in. (914.4 mm) shall be packed in unit quantities of 100-, 200-, or 500-lbs (45-, 91-, or 227-kg) net weight in Category 1 (see 7.6.1) containers, strapped in accordance with 7.6.1.5, and shall require no other protection. The containers may be palletized or tied onto a skidded master-lift. Straight lengths in unit quantities of 50-lbs (23-kg) net weight shall be packed in either a bundle (see 7.8.2.3), carton (see 7.8.2.4), or cylindrical tube (see 7.8.2.5) and shall require no other protection, except shipments of less than 600 lbs (272 kg) to one destination shall be packed in one Category 1 (see 7.6.1) container. Shipments of 600 lbs or more shall be packed in Category 3 (see 7.6.3) containers, maximum 6000-lbs (2722-kg) gross weight.

7.8.2.3 *Bundle*—Units of 50-lbs (23-kg) net weight shall be wrapped (see Fig. 12) in paper conforming to Specification PPP-B-1055, Class B-1 and secured with three girthwise ties, 3/8-in. (9.53-mm) flat-steel strap or equivalent strength round-wire or tape in accordance with Specification D 5330 and shall require no other protection.

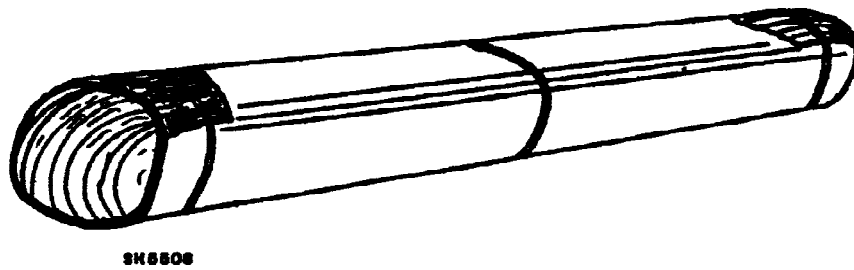

NOTE 1—All dimensions are in inches.  
**FIG. 12 Fifty-Pound Bundle**

7.8.2.4 *Carton*—Units of 50-lbs (23-kg) net weight shall be packed (see Fig. 13) and closed in Category 8 containers (see 7.6.8).

7.8.2.5 *Cylindrical Tube*—Units of 50-lbs (23-kg) net weight shall be packed (see Fig. 14) in spiral-wound cylinders made of chipboard or Kraft with a minimum wall thickness of  $\frac{3}{16}$  in. (4.76 mm). The end closures shall be wood plugs of minimum 1-in. (25.4-mm) thickness and shall be nailed or stapled.

7.8.2.6 *Coils*—Coils of welding rod in the form of round wire shall be wrapped in accordance with Fig. 15 with a single wrap of creped, waterproof paper or overwrapped with one layer of waterproof paper in accordance with 7.3.1 and packed in Category 1, 2, or 3 containers (see 7.6.1-7.6.3). As an alternate, unwrapped coils may be packed in Category 1, 2, or 3 containers (see 7.6.1-7.6.3) containers with a waterproof paper (see 7.3.1) inner liner. Coils exceeding 12 in. (304.8 mm) in diameter shall be wrapped as shown in Fig. 15 with a double layer of creped, waterproof paper in accordance with 7.3.1 and tied securely with not less than three ties evenly spaced around the coil.

7.8.2.7 When specified (see 6.1), bare welding rod in wire form shall be furnished in fiber drums in accordance with Specification PPP-D-723 as follows:

- (1) Grade A, Type II or III for overseas shipments.
- (2) Grade A, Type I for domestic shipment and storage.

NOTE 2—Except where  $\frac{1}{16}$ -in. (11.11-mm) plywood heading is specified,  $\frac{3}{8}$ -in. (9.53-mm) thickness of the bottom headings is permissible.

7.8.2.8 *Drums*—Drums shall be provided with cores fabricated from convolutedly wound Kraft liner-board of minimum

0.012-in. (.304-mm) thickness. When specified (see 6.1), cores shall be fitted with a slinger-ring attachment. Wire shall be of continuous length, coiled in unstressed loops as to lay flat, and be capable of removal for use from top of drum. Drums shall be closed by means of a lever-locking band. Net weight of drum contents will be 400 to 500 lbs (181 to 227 kg). When specified (see 6.1), coiled wire shall be furnished in lighter or heavier net weights. Over-packing of drums for shipment shall not be required. When specified (see 6.1), drums shall be palletized in accordance with MIL-HDBK-774.

7.8.2.9 *Spools*—Welding rod in 25-lbs unit quantities shall be layer wound on spools (see Fig. 16) to avoid producing kinks, waves, or sharp bends and so that it is free to unwind without restriction caused by overlapping and wedging. The final layer of rod shall be covered with a strip of waterproof paper (see 7.3.1). Spools shall be packed in fiberboard boxes constructed and closed in accordance with Class 1 domestic service grade of Practices D 5118 and D 1974. These fiberboard boxes, containing the rod on spools, shall be overpacked in Category 1, 3, or 9 (see 7.6.1, 7.6.3, and 7.6.9) containers, maximum 3000-lbs (1361-kg) gross weight.

7.8.3 *Shafting*:

7.8.3.1 *Levels A and B*—Shafting shall be separated by size, composition, and temper and packed in nailed wood boxes in accordance with 7.6.1.1. Shafting 3 in. (76.2 mm) and under in diameter may be packed more than one to a box. Shafting over 3 in. in diameter shall be individually packed. When specified (see 6.1), shafting  $1\frac{1}{2}$  in. (38.1 mm) to, but not including 3 in. shall be supported within the boxes on wood saddles. The saddles shall be located at each end of the box and every 3 ft

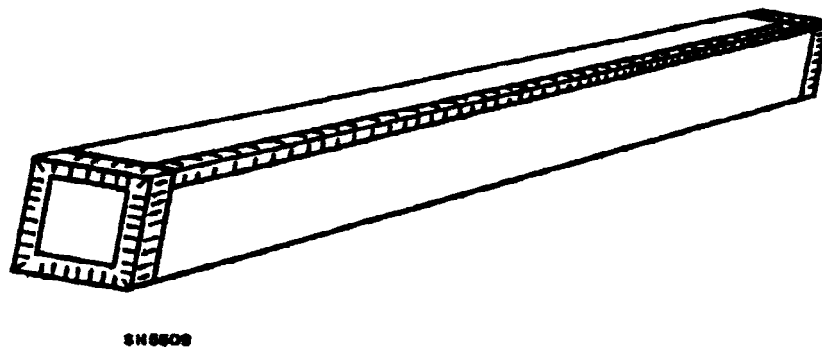

NOTE 1—All dimensions are in inches.  
**FIG. 13 Fifty-Pound Carton**



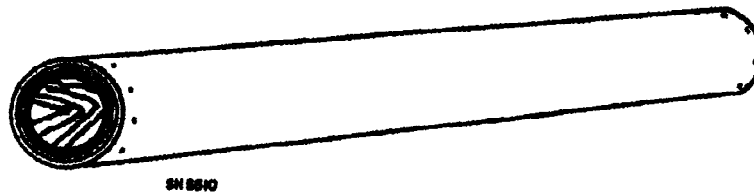

FIG. 14 Fifty-Pound Cylinder

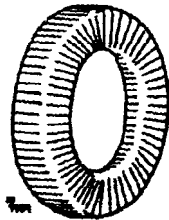
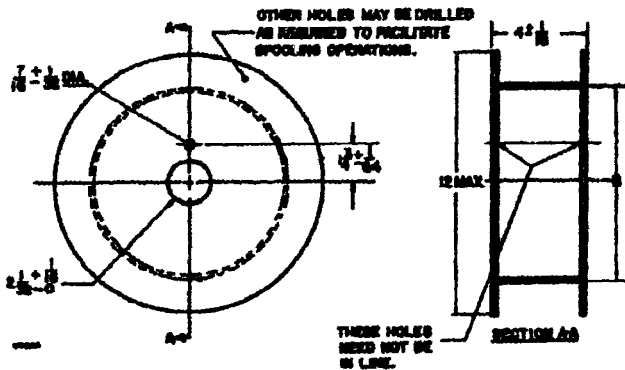

FIG. 15 Typical Wrapped Coiled Round Wire



NOTE 1—Dimension B shall be such as to permit proper feeding of electrode.

NOTE 2—Flanges must not be out of parallel more than  $\frac{3}{16}$  in.

NOTE 3—Flanges and barrel material shall be constructed of such thickness as to provide adequate strength and rigidity to prevent damage or distortion in normal handling or use.

NOTE 4—All dimensions are in inches.

FIG. 16 Standard Spool Dimensions

(914.4 mm) of box length. The saddle shall be of nominal 2-in. (50.8-mm) thickness lumber and the full inside width of the box. The shafting shall be secured within the box by corresponding saddle members placed over the bearing saddles or by members attached to the inside face of the top of the box.

7.8.4 Flat Straight Lengths, Plate, Sheet, Strip, Circles, and Disks:

7.8.4.1 Levels A and B—The products shall be separated by size, composition, and temper and packed in Category 1, 3, or 4 (see 7.6.1-7.6.4) containers. When packed on pallets, in open pallet boxes, or on skidded lifts, the product shall be shrouded with waterproof material 7.3.1. Products with polished surfaces shall be wrapped with interleaving paper in accordance with 7.3.3, packed in Category 1 containers (see 7.6.1), and lined with waterproof material in accordance with 7.3.1.

7.8.5 Sheet Strip in Rolls:

7.8.5.1 Levels A and B—The product shall be separated by size, composition, and temper and packed in either Category 1 or 3 (see 7.6.1 and 7.6.3) containers. When packed on pallets

or in open pallet boxes, the product shall be shrouded in waterproof material in accordance with 7.3.3, packed in Category 1 containers (see 7.6.1), and lined with waterproof material in accordance with 7.3.1.

7.8.6 Cable, Round or Flat Wire—The products shall be separated by size, composition, and temper (Levels A and B).

7.8.6.1 Reels or Spools—When packed on large reels or spools, round or flat wire cable shall be protected by a layer of waterproof material in accordance with 7.3.1 and extending completely around the reel. The paper shall be tacked, taped, or strapped to flanges of the reel. Reels shall be completely enclosed with wooden lagging with boards touching each other as shown on Fig. 17. Lagging boards shall be the same thickness as the flange, but not thicker than 2-in. (50.8-mm) commercial lumber. Lagging boards shall be nailed to the outside of the flanges and secured with flat-steel straps, or equivalent strength round wire. Flat steel straps shall be  $\frac{5}{8}$  by 0.020 in. (15.9 by 0.51 mm). Strapping shall be drawn tight around the periphery of the lagging. The straps shall be stapled or nailed at intervals of approximately 15 in. (381 mm). Product on intermediate reels or spools with flange diameters in the approximate range from 10 to 30 in. (254 to 762 mm) may be covered with plywood or solid fiberboard wrappers. Such covering shall be placed directly over the product and fit between the reel flanges and secured with flat steel straps or equivalent strength round wire. Flat steel straps shall be  $\frac{1}{2}$  by 0.020 in. (12.7 by 0.51 mm), minimum. Product on small reels

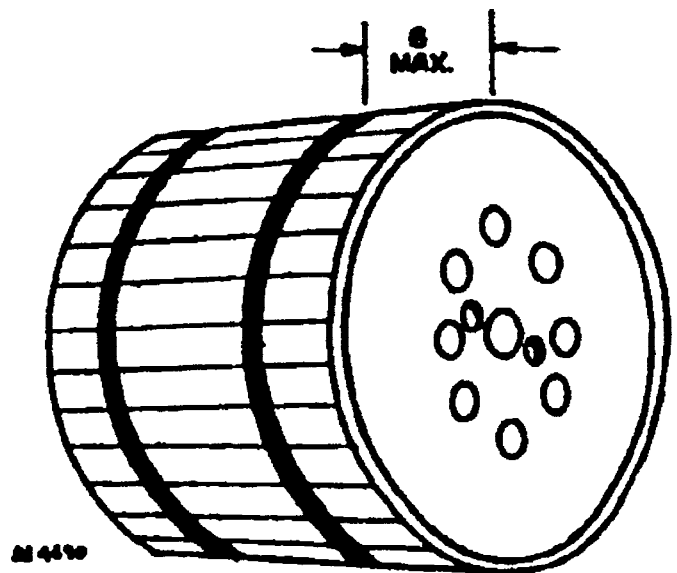

NOTE 1—All dimensions are in inches.

FIG. 17 Typical Lagged Reel for Wire and Cable

or spools (with flange diameters less than approximately 10 in. (254 mm)) may be wrapped in accordance with the manufacturer's standard practice and shall be packed in either Category 1 or 3 (see 7.6.1 and 7.6.3) containers. Whenever practicable, small boxes of individual reels or spools may be palletized or secured onto a skidded master shipping unit. Alternately, reels or spools may be packed with lightweight wire-bound lagging.

**7.8.6.2 Coils (Round Wire)**—Coils of round wire shall be wrapped as shown on Fig. 15 with a single wrap of creped, waterproof material or overwrapped with one layer of waterproof material in accordance with 7.3.1 and packed in Category 1, 2, or 3 containers in accordance with 7.6.1-7.6.3, respectively. As an alternate, unwrapped coils may be packed in Category 1 or 2 containers with a waterproof material (see 7.3.1) liner. Whenever practicable, small packages of individual coils may be palletized or secured onto a skidded master shipping unit. Coils of round wire exceeding 12 in. (304.8 mm) in diameter, wrapped as shown on Fig. 15 with a double layer of creped material in accordance with 7.3.1, and tied securely with not less than three ties evenly spaced around the coil shall require no other external container.

**7.8.6.3 Flat Wire in Coils (Rolls) or on Bucks**—Flat wire in coils (rolls) or on bucks shall be tied with not less than three ties evenly spaced around the unit and packed in Category 1, 2, or 3 containers in accordance with 7.6.1-7.6.3, respectively. To prevent damage to adjacent coils, protectors in accordance with 7.6.6.1 shall be provided between the coils. Whenever practicable, small boxes shall be palletized or secured onto a skidded master shipping unit.

**7.8.7 Tubular Products in Coils:**

**7.8.7.1 Levels A and B**—Tubular products in coils shall be separated by size, composition, and temper and packaged in containers specified in 7.3.4 or in accordance with commercial practice and packed in Category 1, 2, or 3 containers in accordance with 7.6.1-7.6.3, respectively.

**7.8.8 Forgings, Forging Blanks or Slugs, Small-Arms Components (Disks, Cups, Cases, and Jackets, Bushings, Short Tube Blanks, Rotating Band Blanks, and Similar Items:**

**7.8.8.1 Levels A and B**—This product shall be separated by size, composition, and temper and packed in Category 1 or 2 containers or pallet boxes in accordance with 7.6.1-7.6.3, respectively. The contents of pallet boxes shall be shrouded with waterproof material in accordance with 7.3.1. Whenever practicable, small boxes shall be palletized or secured onto a skidded master shipping unit.

**7.9 Marking (for DoD Use Only)**—In addition to any special marking required (see 6.1), marking for shipment shall be in accordance with Standard MIL-STD-129.

**8. Special Government Requirements**

**8.1 Responsibility for Inspection**—Unless otherwise specified in the contract or purchase order, the supplier is responsible for the performance of all inspection requirements as specified herein. Except as otherwise specified in the contract or order, the supplier shall use his own or any other facilities suitable for the performance of the inspection requirements specified herein, unless disapproved by the government as the time the order is placed. The government reserves the right to perform any of the inspections set forth in this practice where

such inspections are deemed necessary to ensure supplies and services conform to prescribed requirements.

**8.2 Sampling for Quality Conformance Inspection:**

**8.2.1 Inspection Lot**—All units of the same product, packed in the same manner, and presented for delivery at one time shall be considered an inspection lot.

**8.2.2 Sampling for Visual and Dimensional Examination**—Random samples of filled containers or unit loads shall be selected from each lot in accordance with Table 7 to verify compliance with all requirements of this practice which do not involve tests.

**8.2.3 Sampling for Moisture Content in Wood**—The total number of pieces of wood in all pallets, skids, and boxes shall be considered the lot size. The number of pieces on which moisture measurement shall be made is shown in Table 8. These pieces shall be selected at random and one moisture meter measurement made on each piece (see 8.4.2).

**8.3 Visual and Dimensional Examination**—Each sample, filled container, or unit load selected from Table 7 shall be visually examined and measured to verify conformance to the workmanship and other requirements of this practice. Examination shall be as specified in Table 9. Any container or unit load in the sample containing one or more defects shall not be offered for delivery, and, if the number of defects in any sample exceeds the acceptance number for that sample, this shall be cause for rejection of the lot represented by the sample.

**8.4 Test Procedures:**

**8.4.1 Tensile Strength and Water Resistance**—The fabricated material (see 7.3.1) shall be tested as specified in Test Methods D 828 and D 779, respectively.

**8.4.2 Moisture Content**—For determining the moisture content of wood either of the following methods shall be used:

**8.4.2.1 Oven-Drying Methods**—A small sample, preferably not smaller than 3 in. (76.2 mm) square, not less than ¾ oz (20 g), shall be cut from the material to be tested. The moisture determination shall be conducted in accordance with Sections 124-127 of Method D 143.

**8.4.2.2 Electrical Moisture-Meter Method**—Electrical moisture-meter method shall be conducted in accordance with Test Methods D 4444.

**8.4.3 Possible Test Failures:**

**8.4.3.1 Tensile Strength and Water Resistance**—Waterproof barrier material not as specified and tensile strength per inch width less than specified.

**8.4.3.2 Water Absorption**—Evidence of water absorption when tested for the specified period by the dry-indicator method of Test Method D 779.

**TABLE 7 Sampling for Visual and Dimensional Examination**

| Lot Size (Number of Containers) | Sample Number of Containers | Acceptance Number of Defects | Rejection Number of Defects |
|---------------------------------|-----------------------------|------------------------------|-----------------------------|
| 1 to 8                          | All                         | ---                          | ---                         |
| 9 to 25                         | 5                           | 0                            | 1                           |
| 26 to 65                        | 7                           | 0                            | 1                           |
| 66 to 110                       | 10                          | 0                            | 1                           |
| 111 to 180                      | 15                          | 0                            | 1                           |
| 181 and over                    | 25                          | 0                            | 1                           |

**TABLE 8 Sampling for Moisture Content in Wood**

| Lot Size, (Number of Pieces) | Sample Size, (Number of Pieces Tested) | Acceptance (Number of Pieces Outside Moisture Limits) |
|------------------------------|--|---|
| Up to 40                     | 5                                      | 0   |
| 41 to 65                     | 7                                      | 0   |
| 66 to 110                    | 10                                     | 0   |
| 111 to 300                   | 15                                     | 0   |
| 301 to 800                   | 25                                     | 0   |
| 801 to 1300                  | 35                                     | 0   |
| 1301 to 3200                 | 50                                     | 0   |
| 3201 to 8000                 | 75                                     | 0   |

8.4.3.3 *Moisture Content*—Not within the specified limit when wood sample is tested by either the oven-drying method or electrical moisture-meter method.

8.4.3.4 Failure to meet any of the test requirements shall be cause for rejection of the entire lot.

## 9. Keywords

9.1 copper; copper alloy; copper alloy bar; copper alloy flat-wire; copper alloy plate; copper alloy rod; copper alloy shafting; copper alloy sheet; copper alloy strip; copper alloy tube; copper bar; copper flat-wire; copper plate; copper rod; copper sheet; copper strip; copper tube; marking; packaging; packing

**TABLE 9 Classification of Defects in Accordance with Standard ANSI/ASQC Z1.4**

| Categories     | Defects  |
|----------------|--|
| Critical:<br>1 | None defined.  |
| Major:         |  |
| 101            | Level of packaging not as specified.   |
| 102            | Packaging not sufficient to afford adequate protection against physical damage.  |
| 103            | Evidence of unauthorized material used.  |
| 104            | Products not separated by size, composition, and temper as specified.  |
| 105            | Net weight of unit package in container exceeds specified limit.   |
| 106            | Coils not wrapped in waterproof paper.   |
| 107            | Shafting (when specified) not supported on saddles; saddles not spaced as required.  |
| 108            | Flat straight lengths, plate, sheet, strip, circles, and disks with polished surfaces not packaged with interleaving paper as required.  |
| 109            | Products in rolls, reels, spools, or coils not shrouded or wrapped in waterproof material as specified.  |
| 110            | Forgings, forging blanks or slugs, small arms components, bushings, short tube-blanks, rotating-band blanks, and similar items not shrouded in waterproof material.                      |
| 111            | Level of packing not as specified.   |
| 112            | Weight of contents relative to the container style exceeds the allowable limit.  |
| 113            | Packing does not ensure acceptance by common carrier or protection against physical damage.  |
| 114            | Shipping containers nonconforming to uniform freight classification.   |
| 115            | Wood for boxes, pallets, reels, and similar items not in accordance with specification as required.  |
| 116            | Veneer, paper-overlaid panel-board nonconforming to Type I or Type II as specified.  |
| 117            | Category of container not as specified.  |
| 118            | Box containers nonconforming to side thicknesses, top and bottom thickness, ends, end cleats, and battens styles as specified.   |
| 119            | Closure banding or strapping not as specified.   |
| 120            | Steel strap size less than the specified minimum in relation to the weight of the box contents.  |
| 121            | Wooden barrels, kegs, and drums nonconforming.   |
| 122            | Pallet surface boards not of uniform width and spacing, thickness less than minimum required, and stringer size and number of stringers less than required.                              |
| 123            | Gross weight of shipping containers exceeds limit specified.   |
| 124            | Skids not provided when required.  |
| 125            | Skids not in accordance with applicable box specifications.  |
| 126            | Spools not within specified dimensions, flanges not parallel, and not constructed with adequate strength and rigidity to prevent damage in normal handling.                              |
| 127            | Bundles, cartons, and cylinders not as specified; weight exceeds the specified limit.  |
| Minor:         |  |
| 201            | Marking; shipment information not provided on interior packages.   |
| 202            | Nomenclature; Federal Stock number; or manufacturer's part number, contract or order number, contractor's name and destination not legible, missing, or improperly marked on containers. |

*ASTM International takes no position respecting the validity of any patent rights asserted in connection with any item mentioned in this standard. Users of this standard are expressly advised that determination of the validity of any such patent rights, and the risk of infringement of such rights, are entirely their own responsibility.*

*This standard is subject to revision at any time by the responsible technical committee and must be reviewed every five years and if not revised, either reapproved or withdrawn. Your comments are invited either for revision of this standard or for additional standards and should be addressed to ASTM International Headquarters. Your comments will receive careful consideration at a meeting of the responsible technical committee, which you may attend. If you feel that your comments have not received a fair hearing you should make your views known to the ASTM Committee on Standards, at the address shown below.*

*This standard is copyrighted by ASTM International, 100 Barr Harbor Drive, PO Box C700, West Conshohocken, PA 19428-2959, United States. Individual reprints (single or multiple copies) of this standard may be obtained by contacting ASTM at the above address or at 610-832-9585 (phone), 610-832-9555 (fax), or [service@astm.org](mailto:service@astm.org) (e-mail); or through the ASTM website ([www.astm.org](http://www.astm.org)).*