



Designation: **B 108 – 03a**

## Standard Specification for Aluminum-Alloy Permanent Mold Castings<sup>1</sup>

This standard is issued under the fixed designation B 108; the number immediately following the designation indicates the year of original adoption or, in the case of revision, the year of last revision. A number in parentheses indicates the year of last reapproval. A superscript epsilon ( $\epsilon$ ) indicates an editorial change since the last revision or reapproval.

*This standard has been approved for use by agencies of the Department of Defense.*

---

<sup>1</sup> This specification is under the jurisdiction of ASTM Committee B07 on Light Metals and Alloys and is the direct responsibility of Subcommittee B07.01 on Aluminum Alloy Ingots and Castings.

Current edition approved ~~June 10, 2003~~; Published ~~September 2003~~; Originally approved in 1936. Last previous edition approved in 2004~~3~~ as B 108 – 04~~a3~~.

## 1. Scope\*

- 1.1 This specification<sup>2</sup> covers aluminum-alloy permanent mold castings designated as shown in Table 1.
- 1.2 This specification is not intended for aluminum-alloy permanent mold castings used in aerospace applications.
- 1.3 Alloy and temper designations are in accordance with ANSI H35.1. The equivalent unified numbering system alloy designations are in accordance with Practice E 527.
- 1.4 For acceptance criteria for inclusion of new aluminum and aluminum alloys and their properties in this specification, see Annex A1 and Annex A2.
- 1.5 The values stated in inch-pound units are to be regarded as the standard. The SI values given in parentheses are for information only.

## 2. Referenced Documents

2.1 The following documents of the issue in effect on the date of casting purchase form a part of this specification to the extent referenced herein:

### 2.2 ASTM Standards:

B 179 Specification for Aluminum Alloys in Ingot Form for Castings from all Casting Processes<sup>3</sup>

B 275 Practice for Codification of Certain Nonferrous Metals and Alloys, Cast and Wrought<sup>3</sup>

<sup>2</sup> For ASME Boiler and Pressure Code application see related SB-108.

<sup>3</sup> Annual Book of ASTM Standards, Vol 02.02.

**TABLE 1 Chemical Composition Limits<sup>A,B,C</sup>**

Alloy		Composition, %											Other Elements <sup>E</sup>	
ANSI <sup>D</sup>	UNS	Aluminum	Silicon	Iron	Copper	Manga- nese	Magne- sium	Chromium	Nickel	Zinc	Tin	Titanium	Each	Total <sup>F</sup>
204.0	A02040	remainder	0.20	0.35	4.2–5.0	0.10	0.15–0.35	...	0.05	0.10	0.05	0.15–0.30	0.05	0.15
242.0	A02420	remainder	0.7	1.0	3.5–4.5	0.35	1.2–1.8	0.25	1.7–2.3	0.35	...	0.25	0.05	0.15
296.0		remainder	2.0–3.0	1.2	4.0–5.0	0.35	0.05	...	0.35	0.50	...	0.25	...	0.35
308.0		remainder	5.0–6.0	1.0	4.0–5.0	0.50	0.10	...	...	1.0	...	0.25	...	0.50
319.0	A03190	remainder	5.5–6.5	1.0	3.0–4.0	0.50	0.10	...	0.35	1.0	...	0.25	...	0.50
332.0 <sup>G</sup>	A03320	remainder	8.5–10.5	1.2	2.0–4.0	0.50	0.50–1.5	...	0.50	1.0	...	0.25	...	0.50
333.0	A03330	remainder	8.0–10.0	1.0	3.0–4.0	0.50	0.05–0.50	...	0.50	1.0	...	0.25	...	0.50
336.0 <sup>G</sup>	A03360	remainder	11.0–13.0	1.2	0.50–1.5	0.35	0.7–1.3	...	2.0–3.0	0.35	...	0.25	0.05	...
354.0	A03540	remainder	8.6–9.4	0.20	1.6–2.0	0.10	0.40–0.6	...	...	0.10	...	0.20	0.05	0.15
355.0	A03550	remainder	4.5–5.5	0.6 <sup>H</sup>	1.0–1.5	0.50 <sup>H</sup>	0.40–0.6	0.25	...	0.35	...	0.25	0.05	0.15
C355.0	A33550	remainder	4.5–5.5	0.20	1.0–1.5	0.10	0.40–0.6	...	...	0.10	...	0.20	0.05	0.15
356.0	A03560	remainder	6.5–7.5	0.6 <sup>H</sup>	0.25	0.35 <sup>H</sup>	0.20–0.45	...	...	0.35	...	0.25	0.05	0.15
A356.0	A13560	remainder	6.5–7.5	0.20	0.20	0.10	0.25–0.45	...	...	0.10	...	0.20	0.05	0.15
357.0		remainder	6.5–7.5	0.15	0.05	0.03	0.45–0.6	...	...	0.05	...	0.20	0.05	0.15
A357.0	A13570	remainder	6.5–7.5	0.20	0.20	0.10	0.40–0.7	...	...	0.10	...	0.04–0.20	0.05 <sup>I</sup>	0.15
359.0	A03590	remainder	8.5–9.5	0.20	0.20	0.10	0.50–0.7	...	...	0.10	...	0.20	0.05	0.15
443.0	A04430	remainder	4.5–6.0	0.8	0.6	0.50	0.05	0.25	...	0.50	...	0.25	...	0.35
B443.0	A24430	remainder	4.5–6.0	0.8	0.15	0.35	0.05	...	...	0.35	...	0.25	0.05	0.15
A444.0	A14440	remainder	6.5–7.5	0.20	0.10	0.10	0.05	...	...	0.10	...	0.20	0.05	0.15
513.0 <sup>G</sup>	A05130	remainder	0.30	0.40	0.10	0.30	3.5–4.5	...	...	1.4–2.2	...	0.20	0.05	0.15
535.0	A05350	remainder	0.15	0.15	0.05	0.10–0.25	6.2–7.5	...	...	...	...	0.10–0.25	0.05 <sup>J</sup>	0.15
705.0	A07050	remainder	0.20	0.8	0.20	0.40–0.6	1.4–1.8	0.20–0.40	...	2.7–3.3	...	0.25	0.05	0.15
707.0	A07070	remainder	0.20	0.8	0.20	0.40–0.6	1.8–2.4	0.20–0.40	...	4.0–4.5	...	0.25	0.05	0.15
711.0 <sup>G</sup>	A07110	remainder	0.30	0.7–1.4	0.35–0.65	0.05	0.25–0.45	...	...	6.0–7.0	...	0.20	0.05	0.15
713.0	A07130	remainder	0.25	1.1	0.40–1.0	0.6	0.20–0.50	0.35	0.15	7.0–8.0	...	0.25	0.10	0.25
850.0	A08500	remainder	0.7	0.7	0.7–1.3	0.10	0.10	...	0.7–1.3	...	5.5–7.0	0.20	...	0.30
851.0 <sup>G</sup>	A08510	remainder	2.0–3.0	0.7	0.7–1.3	0.10	0.10	...	0.3–0.7	...	5.5–7.0	0.20	...	0.30
852.0 <sup>G</sup>	A08520	remainder	0.40	0.7	1.7–2.3	0.10	0.6–0.9	...	0.9–1.5	...	5.5–7.0	0.20	...	0.30

<sup>A</sup> When single units are shown, these indicate the maximum amounts permitted.

<sup>B</sup> Analysis shall be made for the elements for which limits are shown in this table.

<sup>C</sup> The following applies to all specified limits in this table: For purposes of determining conformance to these limits, an observed value or a calculated value obtained from analysis shall be rounded to the nearest unit in the last right-hand place of figures used in expressing the specified limit in accordance with the rounding method of Practice E 29.

<sup>D</sup> ASTM alloy designations are recorded in Practice B 275.

<sup>E</sup> Others includes listed elements for which no specific limit is shown as well as unlisted metallic elements. The producer may analyze samples for trace elements not specified in the specification. However, such analysis is not required and may not cover all metallic Others elements. Should any analysis by the producer or the purchaser establish that an Others element exceeds the limit of Each or that the aggregate of several Others elements exceeds the limit of Total, the material shall be considered nonconforming.

<sup>F</sup> Other Elements—Total shall be the sum of unspecified metallic elements 0.010 % or more, rounded to the second decimal before determining the sum.

<sup>G</sup> 336.0 formerly A332.0, 332.0 formerly F332.0, 513.0 formerly A514.0, 711.0 formerly C712.0, 851.0 formerly A850.0, 852.0 formerly B850.0.

<sup>H</sup> If the iron content exceeds 0.45 %, manganese content shall not be less than one half of the iron.

<sup>I</sup> Beryllium 0.04–0.07.

<sup>J</sup> Beryllium 0.003–0.007, boron 0.005 max.

- B 557 Test Methods for Tension Testing Wrought and Cast Aluminum- and Magnesium-Alloy Products<sup>3</sup>  
B 660 Practices for Packaging/Packing of Aluminum and Magnesium Products<sup>3</sup>  
B 881 Terminology Relating to Aluminum- and Magnesium-Alloy Products<sup>3</sup>  
B 917/B 917M Practice for Heat Treatment of Aluminum-Alloy Castings from All Processes<sup>3</sup>  
E 29 Practice for Using Significant Digits in Test Data to Determine Conformance with Specifications<sup>4</sup>  
E 34 Test Methods for Chemical Analysis of Aluminum and Aluminum-Base Alloys<sup>5</sup>  
E 88 Practice for Sampling Nonferrous Metals and Alloys in Cast Form for Determination of Chemical Composition<sup>5</sup>  
E 94 Guide for Radiographic Testing<sup>6</sup>  
E 155 Reference Radiographs for Examination of Aluminum and Magnesium Castings<sup>6</sup>  
E 165 Test Method for Liquid Penetrant Examination<sup>6</sup>  
E 527 Practice for Numbering Metals and Alloys (UNS)<sup>7</sup>  
E 607 Test Method for Optical Emission Spectrometric Analysis of Aluminum and Aluminum Alloys by the Point-to-Plane Technique, Nitrogen Atmosphere<sup>8</sup>  
E 716 Practices for Sampling Aluminum and Aluminum Alloys for Spectrochemical Analysis<sup>8</sup>  
E 1251 Test Method for Optical Emission Spectrometric Analysis of Aluminum and Aluminum Alloys by the Argon Atmosphere, Point-to-Plane, Unipolar Self-Initiating Capacitor Discharge<sup>8</sup>  
2.3 *ANSI Standard:*  
H35.1 Alloy and Temper Designation Systems for Aluminum<sup>9</sup>  
2.4 *Military Standards:*<sup>9</sup>  
MIL-STD-129 Marking for Shipment and Storage  
MIL-STD-276 Impregnation of Porous Nonferrous Metal Castings  
NAVSEA Technical Publication S9074-AR-GIB-010/278<sup>10</sup>  
2.5 *AMS Specification:*  
AMS 2771 Heat Treatment of Aluminum Alloy Castings<sup>11</sup>  
2.6 *Federal Standard:*<sup>12</sup>  
Fed Std. No. 123 Marking for Shipment (Civil Agencies)

### 3. Terminology

- 3.1 *Definitions*—Refer to Terminology B 881 for definitions of product terms used in this specification.

### 4. Ordering Information

- 4.1 Orders for material under this specification shall include the following information:  
4.1.1 This specification designation (which includes the number, the year, and the revision letter, if applicable),  
4.1.2 Alloy (see Section 7 and Table 1),  
4.1.3 Temper (see Section 11 and Table 2),  
4.1.4 Applicable drawing or part number,  
4.1.5 The quantity in either pieces or pounds.  
4.2 Additionally, orders for material to this specification shall include the following information when required by the purchaser.  
4.2.1 Whether yield strength tests are required (see 11.1 and Table 2, Footnote F),  
4.2.2 Whether castings or test bars, or both, are to be artificially aged for Alloys 705.0-T5, 707.0-T5, and 713.0-T5 (see 11.3),  
4.2.3 Whether test specimens cut from castings are required in addition to or instead of separately cast specimens (see Sections 11, 12.2, 13.2, and 15),  
4.2.4 Whether repairs are permissible (see Section 18),  
4.2.5 Whether inspection is required at the producer's works (see Section 19),  
4.2.6 Whether certification is required (see Section 23),  
4.2.7 Whether surface requirements will be checked visually or by observational standards where such standards are established (see 20.1),  
4.2.8 Whether liquid penetrant inspection is required (see 20.2),

<sup>4</sup> *Annual Book of ASTM Standards*, Vol 14.02.

<sup>5</sup> *Annual Book of ASTM Standards*, Vol 03.05.

<sup>6</sup> *Annual Book of ASTM Standards*, Vol 03.03.

<sup>7</sup> *Annual Book of ASTM Standards*, Vol 01.01.

<sup>8</sup> *Annual Book of ASTM Standards*, Vol 03.06.

<sup>9</sup> Available from American National Standards Institute (ANSI), 25 W. 43rd St., 4th Floor, New York, NY 10036.

<sup>10</sup> Available from Standardization Documents Order Desk, DODSSP, Bldg. 4, Section D, 700 Robbins Ave., Philadelphia, PA 19111-5094. Attn: NPODS.

<sup>11</sup> This specification is under the jurisdiction of ASTM Committee B07 on Light Metals and Alloys and is the direct responsibility of Subcommittee B07.01 on Aluminum Alloy Ingots and Castings.

Current edition approved . Published . Originally approved in 1936. Last previous edition approved in 2003 as B 108 – 03.

<sup>12</sup> Available from Standardization Documents Order Desk, Bldg. 4, Section D, 700 Robbins Ave., Philadelphia, PA 19111-5094, Attn: NPODS.

- 4.2.9 Whether radiographic inspection is required (see 20.3), and  
 4.2.10 Whether foundry control is required (see 10.2).  
 4.2.11 Whether Practices B 660 applies and, if so, the levels of preservation, packaging and packing required (see 24.4).

### 5. Responsibility for Quality Assurance

5.1 Unless otherwise specified in the contract or purchase order, the producer shall be responsible for the performance of all inspections and test requirements specified herein. Unless otherwise agreed upon, the producer may use his own or any other suitable facilities for the performance of the inspection and test requirements specified herein. The purchaser shall have the right to perform any of the inspections and tests set forth in the specification where such inspections are deemed necessary to confirm that the material conforms to prescribed requirements.

### 6. Materials and Manufacture

6.1 The responsibility of furnishing castings that can be laid out and machined to the finished dimensions within the permissible variations specified, as shown on the blueprints or drawings, shall rest with the producer, except where mold equipment is furnished by the purchaser.

### 7. Chemical Composition

7.1 The castings shall conform to the chemical composition limits prescribed in Table 1. Conformance shall be determined by the producer by analyzing samples at the time the castings are poured, or samples taken from castings or tension test specimens representative of the castings. If the producer has determined the chemical composition of the material during the course of manufacture, he shall not be required to sample and analyze the finished product.

**TABLE 2 Tensile Requirements<sup>A,B</sup>**

Alloy		Temper <sup>C</sup>	Tensile Strength, min, ksi (MPa) <sup>D</sup>	Yield Strength <sup>E</sup> (0.2 % offset), min, ksi (MPa) <sup>D</sup>	Elongation in 2 in. or 4 × Diameter, min, %	Typical Brinell Hardness <sup>F</sup> 500-kgf load, 10-mm ball
ANSI <sup>G</sup>	UNS					
204.0	A02040	T4 separately cast specimens	48.0 (331)	29.0 (200)	8.0	...
242.0	A02420	T571	34.0 (234)	...	H	105
		T61	40.0 (276)	...	H	110
296.0	A02960	T4	33.0 (230)	15.0 (105)	4.5	75
		T6	35.0 (240)	...	2.0	90
		T7	33.0 (230)	16.0 (110)	3.0	...
308.0	A03080	F	24.0 (165)	...	...	70
319.0	A03190	F	27.0 (186)	14.0 (97)	2.5	95
332.0 <sup>I</sup>	A03320	T5	31.0 (214)	...	H	105
333.0	A03330	F	28.0 (193)	...	H	90
		T5	30.0 (207)	...	H	100
		T6	35.0 (241)	...	H	105
		T7	31.0 (214)	...	H	90
336.0 <sup>I</sup>	A03360	T551	31.0 (214)	...	H	105
		T65	40.0 (276)	...	H	125
354.0	A03540	T61				
		separately cast specimens	48.0 (331)	37.0 (255)	3.0	
		casting, designated area <sup>J</sup>	47.0 (324)	36.0 (248)	3.0	
		castings, no location designated <sup>J</sup>	43.0 (297)	33.0 (228)	2.0	
		T62				
		separately cast specimens	52.0 (359)	42.0 (290)	2.0	
		castings, designated area <sup>J</sup>	50.0 (344)	42.0 (290)	2.0	
		castings, no location designated <sup>J</sup>	43.0 (297)	33.0 (228)	2.0	
355.0	A03550	T51	27.0 (186)	...	H	75
		T62	42.0 (290)	...	H	105
		T7	36.0 (248)	...	H	90
		T71	34.0 (234)	27.0 (186)	H	80
C355.0	A33550	T61				
		separately cast specimens	40.0 (276)	30.0 (207)	3.0	85–90
		castings, designated area <sup>J</sup>	40.0 (276)	30.0 (207)	3.0	
		castings, no location designated <sup>J</sup>	37.0 (255)	30.0 (207)	1.0	85
356.0	A03560	F	21.0 (145)	10.0 (69)	3.0	
		T6	33.0 (228)	22.0 (152)	3.0	85
		T71	25.0 (172)	...	3.0	70
A356.0	A13560	T61				
		separately cast specimens	38.0 (262)	26.0 (179)	5.0	80–90
		castings, designated area <sup>J</sup>	33.0 (228)	26.0 (179)	5.0	
		castings, no location designated <sup>J</sup>	28.0 (193)	26.0 (179)	3.0	
357.0		T6	45.0 (310)	...	3.0	...
A357.0	A13570	T61				
		separately cast specimens	45.0 (310)	36.0 (248)	3.0	100
		castings, designated area <sup>J</sup>	46.0 (317)	36.0 (248)	3.0	...

**TABLE 2** *Continued*

Alloy		Temper <sup>C</sup>	Tensile Strength, min, ksi (MPa) <sup>D</sup>	Yield Strength <sup>E</sup> (0.2 % offset), min, ksi (MPa) <sup>D</sup>	Elongation in 2 in. or 4 × Diameter, min, %	Typical Brinell Hardness <sup>F</sup> 500-kgf load, 10-mm ball
ANSI <sup>G</sup>	UNS					
359.0	A03590	castings, no location designated <sup>J</sup>	41.0 (283)	31.0 (214)	3.0	...
		T61				
		separately cast specimens	45.0 (310)	34.0 (234)	4.0	90
		castings, designated area <sup>J</sup>	45.0 (310)	34.0 (234)	4.0	
		castings, no location designated <sup>J</sup>	40.0 (276)	30.0 (207)	3.0	
		T62				
		separately cast specimens	47.0 (324)	38.0 (262)	3.0	100
		castings, designated area <sup>J</sup>	47.0 (324)	38.0 (262)	3.0	
443.0 B443.0 A444.0	A04430 A24430 A14440	castings, no location designated <sup>J</sup>	40.0 (276)	30.0 (207)	3.0	
		F	21.0 (145)	7.0 (49)	2.0	45
		F	21.0 (145)	6.0 (41)	2.5	45
513.0 <sup>I</sup>	A05130	T4				
		separately cast specimens	20.0 (138)	...	20	...
535.0	A05350	castings, designated area <sup>J</sup>	20.0 (138)	...	20	...
		F	22.0 (152)	12.0 (83)	2.5	60
705.0	A07050	F	35.0 (241)	18.0 (124)	8.0	...
707.0	A07070	T1 or T5	37.0 (255)	17.0 (117)	10.0	
		T1	42.0 (290)	25.0 (173)	4.0	
711.0 <sup>I</sup>	A07110	T7	45.0 (310)	35.0 (241)	3.0	
		T1	28.0 (193)	18.0 (124)	7.0	70
713.0	A07130	T1 or T5	32.0 (221)	22.0 (152)	4.0	
850.0	A08500	T5	18.0 (124)	...	8.0	
851.0 <sup>I</sup>	A08510	T5	17.0 (117)	...	3.0	
		T6	18.0 (124)	...	8.0	
852.0 <sup>I</sup>	A08520	T5	27.0 (186)	...	3.0	

<sup>A</sup> If agreed upon by manufacturer and the purchaser, other mechanical properties may be obtained by other heat treatments such as annealing, aging, or stress relieving.

<sup>B</sup> For purposes of determining conformance with this specification, each value for tensile strength and yield strength shall be rounded off to the nearest 0.1 ksi, and each value for elongation shall be rounded to the nearest 0.5 %, both in accordance with the rounding method of Practice E 29.

<sup>C</sup> Refer to ANSI H 35.1 for description of tempers.

<sup>D</sup> SI units for information only. For explanation of the SI Unit "MPa" see Appendix X2.

<sup>E</sup> Yield strength to be evaluated only when specified in contract or purchase order.

<sup>F</sup> Hardness values given for information only, not required for acceptance.

<sup>G</sup> ASTM alloy designations are recorded in Practice B 275.

<sup>H</sup> Not required.

<sup>I</sup> 336.0 formerly A332.0, 332.0 formerly F332.0, 513.0 formerly A514.0, 711.0 formerly C712.0, 851.0 formerly A850.0, 852.0 formerly B850.0.

<sup>J</sup> These properties apply only to castings having section thicknesses not greater than 2 in. except that section thicknesses of ¾ in., max, shall apply to Alloy A444.0.

## 8. Sampling for Determination of Chemical Composition

8.1 A sample for determination of chemical composition shall be taken to represent one of the following:

8.1.1 Not more than 4000 lb (1814 kg) of clean castings (gates and risers removed) or a single casting poured from one furnace.

8.1.2 The casting's poured continuously from one furnace in not more than eight consecutive hours.

8.2 Samples for determination of chemical composition shall be taken in accordance with one of the following methods:

8.2.1 *Samples for Chemical Analysis*— Samples for chemical analysis shall be taken by sawing, drilling, or milling the casting or test specimens in such a manner as to be representative of the material (Practice E 88). The weight of a prepared sample shall not be less than 75 g.

8.2.2 *Samples for Spectrochemical and Other Methods of Analysis*— Samples for spectrochemical analysis shall be taken in accordance with Practices E 716. Samples for other methods of analysis shall be suitable for the form of material being analyzed and the type of analytical methods used.

## 9. Methods for Determination of Chemical Composition

9.1 The determination of chemical composition shall be made in accordance with suitable chemical (Test Methods E 34), or spectrochemical (Test Methods E 607 and E 1251), methods. Other methods may be used only when no published ASTM method is available. In case of dispute, the method of analysis shall be agreed upon by the producer and the purchaser.

## 10. Requirements for Castings Produced for Governmental and Military Agencies

### 10.1 Material Requirements:

10.1.1 Unless otherwise specified, only aluminum alloy conforming to the requirements of Specification B 179 or producers foundry scrap, identified as being made from alloy conforming to Specification B 179, shall be used in the remelting furnace from which molten metal is taken for pouring directly into castings. Additions of small amounts of modifying and grain refining elements or alloys are permitted.

10.1.2 Pure materials, recycled materials, and master alloys may be used to make alloys conforming to this specification, provided chemical analysis can be taken and adjusted to conform to Table 1 prior to pouring any castings.

10.2 *Foundry Control*—When specified, castings shall be produced under foundry control approved by the purchaser. Foundry control shall consist of examination of castings by radiographic or other approved methods for determining internal discontinuities until the gating, pouring, and other foundry practices have been established to produce castings meeting the quality standards furnished by the purchaser or agreed upon by the purchaser and the producer. When foundry practices have been so established, the production method shall not be significantly changed without demonstrating to the satisfaction of the purchaser that the change does not adversely affect the quality of the castings. Minor changes of  $\pm 50^{\circ}\text{F}$  ( $\pm 28^{\circ}\text{C}$ ) from the established nominal temperature are permissible.

## 11. Tensile Requirements

11.1 The separately cast tension test specimens representing the castings shall meet the mechanical properties prescribed in Table 2.

11.2 When specified, the tensile strength and elongation of test specimens cut from castings shall be in accordance with Table 2 for Alloys 354.0, C355.0, A356.0, A357.0, and A444.0. For other alloys a minimum of 75 % of the tensile and yield strength values and not less than 25 % of the elongation values specified in Table 2 are required. The measurement of elongation is not required for test specimens cut from castings if 25% of the specified minimum elongation value published in Table 2 is 0.5 % or less. If grade D quality castings as described in Table 3 are specified, no tensile tests shall be specified nor tensile requirements be met on specimens cut from castings.

11.3 Although Alloys 705.0, 707.0, and 713.0 are most frequently used in the naturally aged condition, by agreement of the producer and the purchaser, the castings may be artificially aged. The producer and the purchaser may also agree to base the acceptance of castings on artificially aged test bars. The conditions of artificial aging shown in Practice B 917/B 917M or AMS 2771 shall be employed unless other conditions are accepted by mutual consent.

## 12. Test Specimens

12.1 Separately cast test specimens shall be cast in iron molds. A recommended gating method is shown in Fig. 1. The test section of the tension test specimen shall be cast to size in accordance with the dimensions shown in Fig. 1 and not machined prior to test. Grip ends may be machined to adapt them in such a manner as to ensure axial loading.

12.2 When properties of castings are to be determined, tension test specimens shall be cut from the locations designated on the drawings, unless otherwise negotiated. If no locations are designated, one or more specimens shall be taken to include locations having significant variation in casting thickness, except that specimens shall not be taken from areas directly under risers. The tension test specimens shall be the standard 0.500-in. diameter specimens shown in Fig. 9 of Test Methods B 557 or a round specimen of smaller size proportional to the standard specimens. In no case shall the dimensions of the smallest specimen be less than the following:

Diameter of reduced section, 0.250 in.  
 Length of reduced section,  $1\frac{1}{4}$  in.  
 Radius of fillet,  $\frac{3}{16}$  in.  
 Diameter of end section,  $\frac{3}{8}$  in.  
 Overall length:  
     With shouldered ends,  $2\frac{3}{8}$  in.  
     With threaded ends, 3 in.  
     With plain cylindrical ends, 4 in.

12.3 When necessary, a rectangular specimen may be used proportional to that shown for the 0.500 in. wide specimen in Fig. 6 of Test Methods B 557, but in no case shall its dimensions be less than the following:

**TABLE 3 Discontinuity—Level Requirements for Aluminum Castings in Accordance with Reference Radiographs E 155**

Discontinuity	Grade A <sup>A</sup>		Grade B		Grade C		Grade D	
	Section Thickness, in. (mm)							
	$\frac{1}{4}$ to $\frac{3}{4}$ (6.4 to 19.0)	$\frac{1}{4}$ (6.4)	$\frac{3}{4}$ (19.0)	$\frac{1}{4}$ (6.4)	$\frac{3}{4}$ (19.0)	$\frac{1}{4}$ (6.4)	$\frac{3}{4}$ (19.0)	
Gas holes	none	1	1	2	2	5	5	
Gas porosity (round)	none	1	1	3	3	7	7	
Gas porosity (elongated)	none	1	1	3	4	5	5	
Shrinkage cavity	none	1	<sup>B</sup>	2	<sup>B</sup>	3	<sup>B</sup>	
Shrinkage porosity or sponge	none	1	1	2	2	4	3	
Foreign material (less dense material)	none	1	1	2	2	4	4	
Foreign material (more dense material)	none	1	1	2	1	4	3	
Segregation	none		none		none		none	
Cracks	none		none		none		none	
Cold shuts	none		none		none		none	
Surface irregularity								
Core shaft								

<sup>A</sup> Caution should be exercised in requesting grade A because of the difficulty in obtaining this level.

<sup>B</sup> No radiographs available.

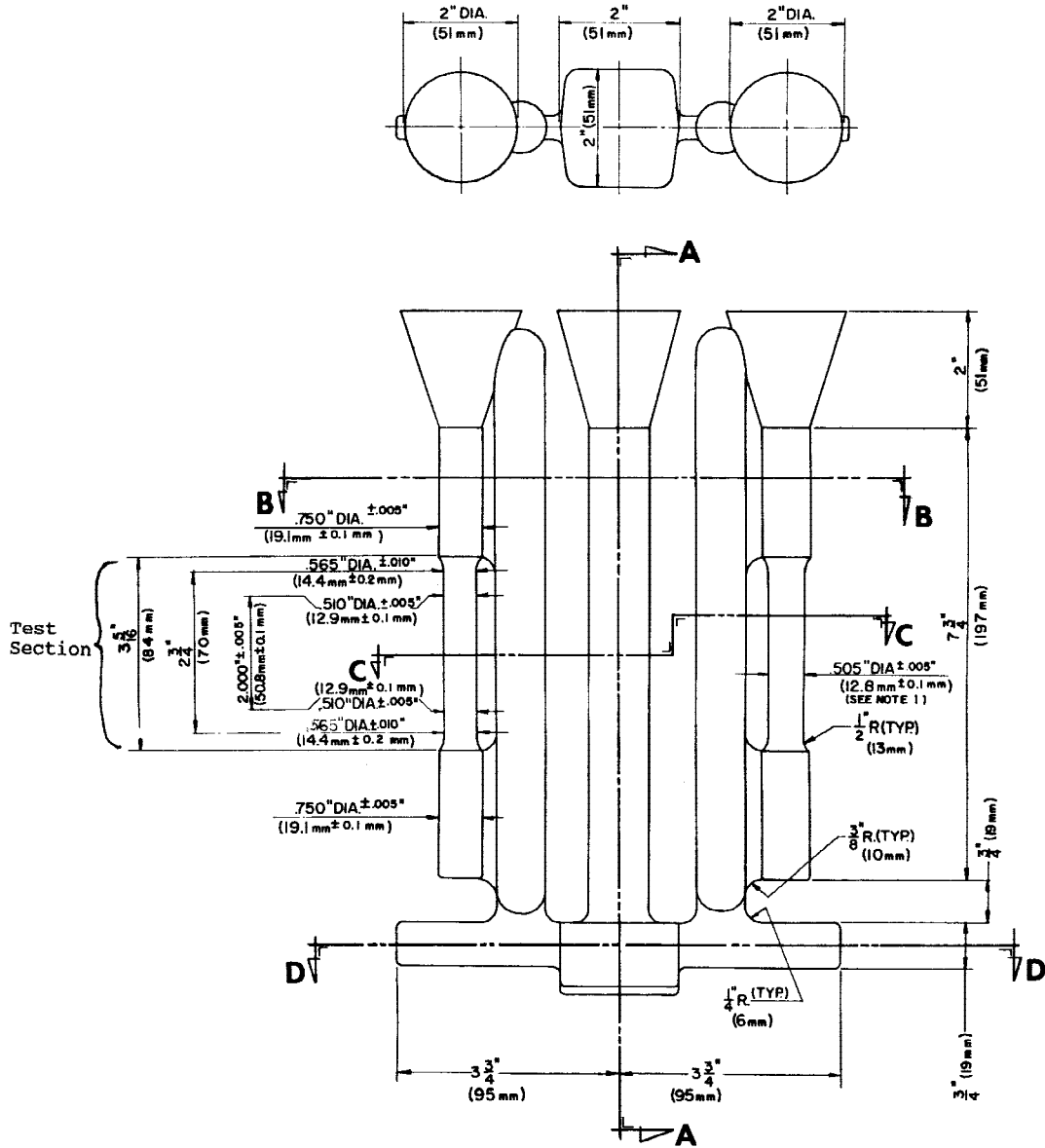

Nominal draft angle to be 20° on all square or rectangular sections in direction transverse to parting line.

NOTE 1—Test section of test bar: this section to be gradually tapered from the ends towards the center.

FIG. 1 Tension Test Specimen Casting

Width of reduced section, 1/4 in.  
 Length of reduced section, 1 1/4 in.  
 Radius of fillet, 1/4 in.  
 Overall length, 4 in.

The specified elongation values shall not apply to tests of rectangular specimens.

12.4 If the castings are to be heat treated and separately cast specimens are to be used, the specimens representing such castings shall be heat treated with the castings they represent. If castings are to be heat treated and tests are to be obtained on the castings, the test specimens shall be taken from the castings after heat treatment.

### 13. Number of Tests

13.1 Unless otherwise agreed upon by the purchaser and producer, two tension test specimens shall be separately cast and tested to represent the following:

13.1.1 Not more than 4000 lb (1814 kg) of clean castings (gates and risers removed) or a single casting poured from one furnace.

13.1.2 The castings poured continuously from one furnace in not more than eight consecutive hours.

13.2 When tensile properties of castings are to be determined, one per melt-heat combination shall be tested unless otherwise shown on the drawing or specified in the purchase order.

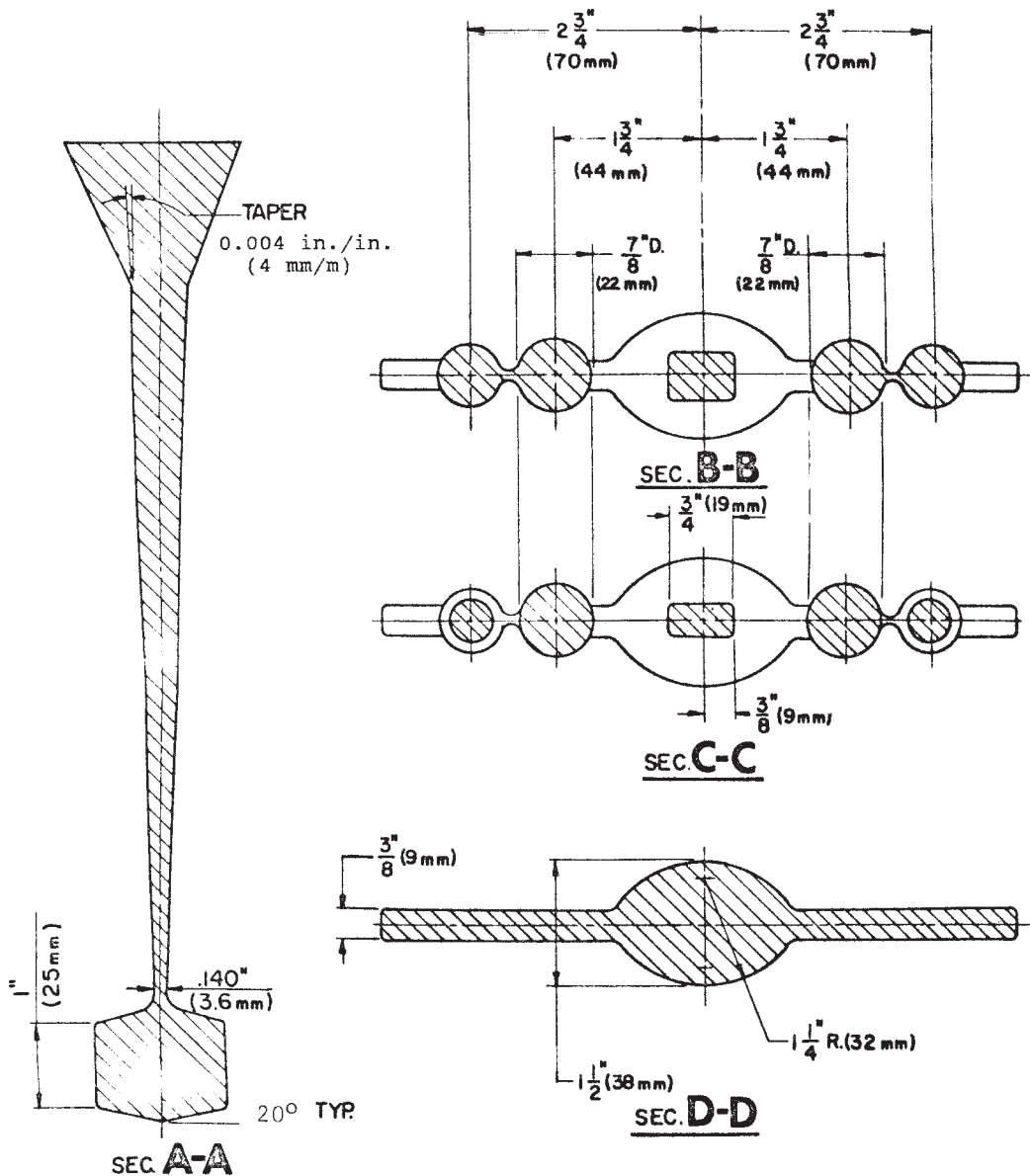

FIG. 2 Tension Test Specimen Casting (Cross Section)

13.3 If any test specimen shows defective machining or flaws, it may be discarded, in which case the purchaser and the producer shall agree upon the selection of a replacement specimen.

#### 14. Test Methods

14.1 The tensile properties shall be determined in accordance with Test Methods B 557.

#### 15. Retests

15.1 If the results of the tension test do not conform to the requirements prescribed in Table 2, test bars representative of the castings may be retested in accordance with the replacement tests and retest provisions of Test Methods B 557 and the results of retests shall conform to the requirements as to mechanical properties specified in Table 2.

#### 16. Workmanship, Finish, and Appearance

16.1 The finished castings shall be uniform in composition and free of blowholes, cracks, shrinks, and other discontinuities in accordance with standards designated and agreed upon as acceptable by the purchaser.

#### 17. Heat Treatment

17.1 Heat treatment of castings shall be performed in accordance with Practice B 917/B 917M or AMS 2771.



## 18. Repair of Castings

18.1 Castings may be repaired only by processes approved and agreed upon by the producer and purchaser, such as, welding, impregnation, peening, blending, soldering, etc., and so forth. Limitations on the extent and frequency of such repairs, and methods of inspection of repaired areas should also be agreed upon.

18.2 *Repairing of Castings Produced for Governmental and Military Agencies:*

18.2.1 *Welding:*

18.2.1.1 When welding is permitted, it shall be done by methods suitable for the particular alloy. Welding methods shall be in accordance with such specifications as are referenced on the applicable drawings, or as are required by the contract or order.

18.2.1.2 All welding shall be done by qualified welders and by methods approved by the purchaser.

18.2.1.3 When castings are to be supplied in the heat treated condition, they shall be heat treated to the required temper after welding, except that small arc welds may be performed without subsequent heat treatment upon approval of the purchaser.

18.2.1.4 Unless otherwise specified, castings that have been repaired by welding shall have the welded areas examined radiographically after all reworking and heat treatment have been completed.

18.2.1.5 All welds shall be free from cracks, lack of fusion, and meet the same quality requirements as the parent material.

18.2.1.6 Welded castings shall be marked with a symbol of three concentric circles with a letter or number designating the welder adjacent to the symbol. The outer circle of the symbol shall be no larger than ¼ in. (6 mm) in outside diameter. All welded areas shall be encircled with a ring or white paint prior to submission for final inspection.

18.2.1.7 Repair welding of castings used in naval shipboard pressure vessels, piping systems, and machinery shall be performed in accordance with requirements for repair of castings specified in NAVSEA Technical Publication S9074-AR-GIB-010/278.

18.3 *Impregnation*—When impregnation is permitted, it shall be to correct general seepage leaks only and shall not be used to correct poor foundry technique or porosity in excess of accepted standards. It shall be accomplished in accordance with MIL-STD-276. Unless otherwise authorized by the purchaser, castings which have been impregnated shall be marked “IMP”.

18.4 *Peening*—When peening is permitted, it shall be to correct localized minor seepage leaks and small surface imperfections only, or to disclose subsurface voids for the purpose of inspection. Peening will not be permitted to repair cracks, cold shuts, shrinks, misruns, defects due to careless handling, or other similar major defects. Peening may be accomplished either hot or cold and shall be performed by methods which are acceptable to the purchaser. Peened castings shall be marked with a Maltese cross approximately ¼ in. (6 mm) high.

18.5 *Blending*—Blending with suitable grinders or other tools will be permitted for the removal of surface imperfections only, and shall not result in dimensions outside the tolerances shown on the applicable drawings.

## 19. Source Inspection

19.1 If the purchaser elects to make an inspection of the castings at the producer’s works, it shall be so stated in the contract or order.

19.2 If the purchaser elects to have an inspection made at the producer’s works, the producer shall afford the inspector all reasonable facilities to satisfy him that the material is being furnished in accordance with this specification. All tests and inspections shall be so conducted as not to interfere unnecessarily with the operation of the works.

## 20. Foundry Inspection

20.1 Requirements such as surface finish, parting line projections, snagging projections where gates and risers were removed, etc., and so forth, may be checked visually. It is advisable to have agreed upon observational standards representing both acceptable and unacceptable material.

20.2 *Liquid Penetrant Inspection :*

20.2.1 When specified, liquid penetrant inspection shall be in accordance with Test Method E 165, and the required sensitivity shall be specified.

20.2.2 Acceptance standards for discontinuities shall be agreed upon, including size and frequency per unit area and location.

20.3 *Radiographic Inspection:*

20.3.1 When specified, radiographic inspection shall be in accordance with Guide E 94 and Reference Radiographs E 155.

20.3.2 Radiographic acceptance shall be in accordance with the requirements selected from Table 3. Any modifications of the table and the frequency per unit area and location of discontinuities should also be agreed upon.

20.3.3 The number, film size and orientation of radiographs, and the number of castings radiographically inspected shall be agreed upon by the producer and purchaser.

## 21. Identification and Repair Marking for Castings Produced for Government and Military Agencies

21.1 *Identification*—Unless otherwise specified, each casting shall be marked with the applicable drawing or part number. The marking shall consist of raised Arabic numbers, and when applicable upper-case letters, cast integral. The location of the identification marking shall be as specified on the applicable drawing. When the location is not specified on the drawing, the drawing or part number, or both, shall be placed in a location mutually agreeable to the purchaser and producer.

21.2 *Lot Identification*—When practical, each casting shall also be marked with the melt or inspection lot number.

21.3 *Lot*—A lot shall consist of all of the cleaned castings poured from the same heat or melt when subsequent heat treatment is not required.

21.3.1 When the castings consist of alloys that require heat treatment, the lot shall consist of all castings from the same melt or heat that have been heat treated in the same furnace charge, or if heat treated in a continuous furnace, all castings from the same melt or heat that are discharged from the furnace during a 4-h period.

21.4 *Repair Marking*—All identification markings indicating repairs as specified in 20.1, 20.2, and 20.3 shall be made with a waterproof marking fluid.

## **22. Rejection and Rehearing**

22.1 Material that fails to conform to the requirements of this specification may be rejected. Rejection should be reported to the producer promptly and in writing. In case of dissatisfaction with the results of the test, the producer may make claim for a rehearing.

## **23. Certification**

23.1 The producer shall, upon request, furnish to the purchaser a certificate stating that each lot has been sampled, tested, and inspected in accordance with this specification, and has met the requirements.

## **24. Packaging, Marking, and Shipping**

24.1 The material shall be packaged in such a manner as to prevent damage in ordinary handling and transportation. The type of packaging and gross weight of individual containers shall be left to the discretion of the producer unless otherwise agreed upon. Packaging methods and containers shall be so selected as to permit maximum utility of mechanical equipment in unloading and subsequent handling. Each package or container shall contain only one part number, alloy, and temper of material when packaged for shipment unless otherwise agreed upon.

24.2 Each package or container shall be marked with the purchase order number, part number, quantity, specification number, alloy and temper, gross and net weights, and the name of the producer.

24.3 Packages or containers shall be such as to ensure acceptance by common or other carriers for safe transportation at the lowest rate to the point of delivery.

24.4 When specified in the contract or purchase order, material shall be preserved, packaged, and packed in accordance with the requirement of Practices B 660. The applicable levels shall be as specified in the contract or order. Marking for shipment of such material shall be in accordance with Fed. Std. No. 123 for civil agencies and MIL-STD-129 for military agencies.

## **25. Keywords**

25.1 aluminum; permanent mold castings

## **ANNEXES**

### **(Mandatory Information)**

#### **A1. BASIS FOR INCLUSION OF PROPERTY LIMITS**

A1.1 Limits are established at a level at which a statistical evaluation of the data indicates that 99 % of the population obtained from all standard material meets the limit with 95 % confidence. For the products described, mechanical property limits for the respective size ranges are based on the analyses of at least 100 data from standard production material with no more than ten data from a given lot. All tests are performed in accordance with the appropriate ASTM test methods. For informational purposes, refer to “Statistical Aspects of Mechanical Property Assurance” in the Related Material section of the *Annual Book of ASTM Standards*, Vol 02.02.

#### **A2. ACCEPTANCE CRITERIA FOR INCLUSION OF NEW ALUMINUM AND ALUMINUM ALLOYS IN THIS SPECIFICATION**

A2.1 Prior to acceptance for inclusion in this specification, the composition of wrought or cast aluminum or aluminum alloy shall be registered in accordance with ANSI H35.1. The Aluminum Association<sup>13</sup> holds the Secretariat of ANSI H35 Committee and administers the criteria and procedures for registration.

A2.2 If it is documented that the Aluminum Association could not or would not register a given composition, an alternative

<sup>13</sup> The Aluminum Association, 900 19th Street, NW, Washington, DC 20006.

procedure and the criteria for acceptance shall be as follows:

A2.2.1 The designation submitted for inclusion does not utilize the same designation system as described in ANSI H35.1. A designation not in conflict with other designation systems or a trade name is acceptable.

A2.2.2 The aluminum or aluminum alloy has been offered for sale in commercial quantities within the prior twelve months to at least three identifiable users.

A2.2.3 The complete chemical composition limits are submitted.

A2.2.4 The composition is, in the judgement of the responsible subcommittee, significantly different from that of any other aluminum or aluminum alloy already in this specification.

A2.2.5 For codification purposes, an alloying element is any element intentionally added for any purpose other than grain refinement and for which minimum and maximum limits are specified. Unalloyed aluminum contains a minimum of 99.00 % aluminum.

A2.2.6 Standard limits for alloying elements and impurities are expressed to the following decimal places:

Less than 0.001 %	0.000X
0.001 to but less than 0.01 %	0.00X
0.01 to but less than 0.10 %	
Unalloyed aluminum made by a refining process	0.0XX
Alloys and unalloyed aluminum not made by a refining process	0.0X
0.10 through 0.55 %	0.XX
(It is customary to express limits of 0.30 through 0.55 % as 0.X0 or 0.X5)	
Over 0.55 %	0.X, X.X, etc.
(Except that combined Si + Fe limits for 99.00 % minimum aluminum must be expressed as 0.XX or 1.XX)	

A2.2.7 Standard limits for alloying elements and impurities are expressed in the following sequence: Silicon; Iron; Copper; Manganese; Magnesium; Chromium; Nickel; Zinc (Note A2.1); Titanium; Other Elements, Each; Other Elements, Total; Aluminum (Note A2.2).

NOTE A2.1—Additional specified elements having limits are inserted in alphabetical order of their chemical symbols between zinc and titanium, or are specified in footnotes.

NOTE A2.2—Aluminum is specified as *minimum* for unalloyed aluminum and as a *remainder* for aluminum alloys.

## APPENDIXES

### (Nonmandatory Information)

#### X1. PROPERTIES AND CHARACTERISTICS

X1.1 Data in Table X1.1 are approximate and are supplied for general information only.

#### X2. METRIC EQUIVALENTS

X2.1 The SI unit for strength properties now shown is in accordance with the International System of Units (SI). The derived SI unit for force is the newton (N), which is defined as that force which when applied to a body having a mass of one kilogram gives it an acceleration of one metre per second squared ( $N = \text{kg}\cdot\text{m}/\text{s}^2$ ). The derived SI unit for pressure or stress is the newton per square metre ( $\text{N}/\text{m}^2$ ), which has been named the pascal (Pa) by the General Conference on Weights and Measures. Since  $1 \text{ ksi} = 6\,894\,757 \text{ Pa}$ , the metric equivalents are expressed as megapascal (MPa), which is the same as  $\text{MN}/\text{m}^2$  and  $\text{N}/\text{mm}^2$ .

TABLE X1.1 Properties and Characteristics

NOTE—1—indicates best of group; 5 indicates poorest of group.

Alloy		Approximate Melting Range °F <sup>B</sup> [°C]	Foundry Characteristics					Other Characteristics									
ANSI <sup>A</sup>	UNS		Resistance to Hot Cracking <sup>C</sup>	Pressure Tightness	Fluidity <sup>D</sup>	Solidification Shrinkage Tendency <sup>E</sup>	Normally Heat-Treated	Resistance to Corrosion <sup>F</sup>	Machining <sup>G</sup>	Polishing <sup>H</sup>	Electroplating <sup>I</sup>	Anodizing (Appearance) <sup>J</sup>	Chemical Oxide Coating (Protection) <sup>K</sup>	Strength at Elevated Temp <sup>L</sup>	Suitability for Welding <sup>M</sup>	Suitable for Brazing <sup>N</sup>	
204.0	A02040	985 to 1200 [529-649]	4	3	3	4	yes	4	1	2	1	3	4	1	4	no	
242.0	A02420	990 to 1175 [532-635]	4	4	3	4	yes	4	2	2	1	2	3	1	4	no	
296.0	A02960	970 to 1170 [521-632]	4	3	3	4	yes	4	1	2	1	3	4	1	4	no	
308.0	A03080	970 to 1135 [521-613]	2	2	2	3	yes	4	3	3	2	4	3	3	2	no	
319.0	A03190	950 to 1125 [510-607]	2	2	2	3	yes	3	3	3	2	4	3	3	2	no	
336.0 <sup>O</sup>	A03360	1080 to 1050 [538-566]	1	2	1	3	yes	3	4	5	4	5	2	2	2	no	
332.0 <sup>O</sup>	A03320	970 to 1080 [521-582]	1	2	1	2	aged only	3	3	4	3	5	3	3	2	no	
333.0	A03330	960 to 1085 [516-585]	2	2	2	3	no	3	3	3	3	5	3	3	2	no	
354.0	A03540	1015 to 1150 [546-621]	1	1	2	2	yes	3	3	3	2	4	2	2	2	no	
355.0	A03550	1015 to 1150 [546-621]	1	1	2	2	yes	3	3	3	2	4	2	2	2	no	
C355.0	A33550	1015 to 1150 [546-621]	1	1	2	2	yes	3	3	3	2	4	2	2	2	no	
356.0	A03560	1035 to 1135 [557-613]	1	1	2	1	yes	2	3	3	1	4	2	3	2	no	
A356.0	A13560	1035 to 1135 [557-613]	1	1	2	1	yes	2	3	3	1	4	2	3	2	no	
A357.0	A13570	1035 to 1135 [557-613]	1	1	2	1	yes	2	3	3	1	4	2	3	2	no	
359.0	A03590	1035 to 1135 [557-613]	1	1	2	1	yes	2	3	3	1	4	2	3	2	no	
443.0	A04430	1065 to 1170 [574-632]	1	1	1	2	no	3	5	4	2	4	2	4	1	ltd	
B443.0	A24430	1065 to 1170 [574-632]	1	1	1	2	no	2	5	4	2	4	2	4	1	ltd	
A444.0	A14440	1065 to 1145 [574-618]	1	1	1	1	yes	2	5	4	2	4	2	4	1	ltd	
513.0 <sup>O</sup>	A05130	1075 to 1180 [579-638]	4	5	5	4	no	1	1	1	4	1	1	3	5	no	
535.0	A05350	1020 to 1165 [549-629]	4	5	5	5	no	1	1	1	5	1	1	3	4	no	
705.0	A07050	1105 to 1180 [596-638]	5	4	4	5	aged only	2	1	1	3	1	2	5	4	yes	
707.0	A07070	1085 to 1165 [585-629]	5	4	4	5	yes	2	1	1	3	1	2	5	5	yes	
711.0 <sup>O</sup>	A07110	1120 to 1190 [604-643]	5	4	4	5	aged only	2	1	1	2	1	2	5	4	yes	
713.0	A07130	1100 to 1185 [593-641]	5	4	4	5	aged only	2	1	1	2	1	2	5	4	yes	
850.0	A08500	435 to 1200 [224-649]	5	5	5	5	aged only	3	1	1	5	4	5	<sup>P</sup>	5	no	



TABLE X1.1 Continued

Alloy		Foundry Characteristics						Other Characteristics								
ANSI <sup>A</sup>	UNS	Approximate Melting Range °F <sup>B</sup> [°C]	Resistance to Hot Cracking <sup>C</sup>	Pressure Tightness	Fluidity <sup>D</sup>	Solidification Shrinkage Tendency <sup>E</sup>	Normally Heat-Treated	Resistance to Corrosion <sup>F</sup>	Machining <sup>G</sup>	Polishing <sup>H</sup>	Electroplating <sup>I</sup>	Anodizing (Appearance) <sup>J</sup>	Chemical Oxide Coating (Protection) <sup>K</sup>	Strength at Elevated Temp <sup>L</sup>	Suitability for Welding <sup>M</sup>	Suitable for Brazing <sup>N</sup>
851.0 <sup>O</sup>	A08510	440 to 1165 [227-629]	4	4	5	4	yes	3	1	1	5	4	5	P	5	no
852.0 <sup>O</sup>	A08520	400 to 1175 [204-635]	5	5	5	5	aged	3	1	1	5	4	5	P	5	no

<sup>A</sup> ASTM alloy designations are recorded in Practice B 275.

<sup>B</sup> Temperatures of solidus and liquidus are indicated, pouring temperatures will be higher.

<sup>C</sup> Ability of alloy to withstand stresses from contraction while cooling through hot-short or brittle temperature range.

<sup>D</sup> Ability of liquid alloy to flow readily in mold and fill thin sections.

<sup>E</sup> Decrease in volume accompanying freezing of alloy and measure of amount of compensating feed metal required in form of risers.

<sup>F</sup> Based on resistance of alloy in standard type salt-spray test.

<sup>G</sup> Composite rating based on ease of cutting, chip characteristics, quality of finish, and tool life. Ratings, in the case of heat-treatable alloys, based on T6 temper. Other tempers, particularly the annealed temper, may have lower rating.

<sup>H</sup> Composite rating based on ease and speed of polishing and quality of finish provided by typical polishing procedure.

<sup>I</sup> Ability of casting to take and hold an electroplate applied by present standard methods.

<sup>J</sup> Rates of lightness of color, brightness, and uniformity of clear anodized coating applied in sulfuric acid electrolyte.

<sup>K</sup> Rated on combined resistance of coating and base alloy to corrosion.

<sup>L</sup> Rating based on tensile and yield strengths at temperatures up to 500°F, after prolonged heating at testing temperature.

<sup>M</sup> Based on ability of material to be fusion-welded with filler rod or same alloy.

<sup>N</sup> Refers to suitability of alloy to withstand brazing temperatures without excessive distortion or melting.

<sup>O</sup> 336.0 formerly A332.0, 332.0 formerly F332.0, 513.0 formerly A514.0, 711.0 formerly C712.0, 851.0 formerly A850.0, 852.0 formerly B850.0.

<sup>P</sup> Not recommended for service at elevated temperatures.

### X3. INACTIVE ALLOYS

X3.1 Alloys listed as inactive by the Aluminum Association—208.0 and 222.0. Listing the composition limits, mechanical properties, and characteristics of the alloys is a method of preserving this data should it be needed at some future date.

**TABLE X3.1 Chemical Composition Limits—Inactive Alloys**

NOTE 1—All applicable notes and footnotes can be found in Table 1

Alloy		Aluminum	Composition, %										Other Elements	
ANSI	UNS		Silicon	Iron	Copper	Man-ganese	Magne-sium	Chromium	Nickel	Zinc	Tin	Titanium	Each	Total
208.0	A02080	remainder	2.5-3.5	1.2	3.5-4.5	0.50	0.10	...	0.35	1.0	...	0.25	...	0.50
222.0	A02220	remainder	2.0	1.5	9.2-10.7	0.50	0.15-0.35	...	0.50	0.8	...	0.25	...	0.35

**TABLE X3.2 Tensile Requirements (Inch-Pound Units)—Inactive Alloys**

NOTE 1—All applicable notes and footnotes can be found in Table 2.

Alloy		Temper	Tensile Strength, min, ksi	Yield Strength (0.2 % offset), min, ksi (MPa)	Elongation in 2 in. or 4 x diameter, min, %	Typical Brinell Hard- ness, 500 kgf, 10 mm
ANSI	UNS					
208.0	A02080	F	19.0 (131)	120 (83)	1.5	55
222.0	A02220	O	23.0 (159)			80
		T6	30.0 (207)			115

**TABLE X3.3 Properties and Characteristics—Inactive Alloys**

NOTE 1—1 indicates best of group, 5 indicates poorest of group.

NOTE 2—All applicable notes and footnotes can be found in Table X1.1.

Alloy		Pattern Shrinkage Allowance, <sup>A</sup> in./ft [mm/m]	Approximate Melting Range, <sup>B</sup> °F [°C]	Resist- ance to Hot Crack- ing <sup>G</sup>	Pressure Tightness	Fluid- ity <sup>C</sup>	Solidi- fication Shrink- age Tend- ency <sup>D</sup>	Normally Heat Treated	Resist- ance to Corro- sion <sup>E</sup>	Machin- ing <sup>F</sup>	Polish- ing <sup>H</sup>	Electro- plating <sup>I</sup>	Anodiz- ing (Ap- pear- ance) <sup>J</sup>	Chemical Oxide Coating ( Protec- tion) <sup>A</sup>	Strength at Ele- vated Tempera- ture <sup>B</sup>	Suitabil- ity for Weld- ing <sup>C</sup>	Suitabil- ity for Brazing <sup>D</sup>
ANSI <sup>F</sup>	UNS																
208.0	A02080	$\frac{5}{32}$ [13]	970-1160 [521-627]	2	2	2	2	yes	4	3	3	2	3	3	3	2	no
222.0	A02220	$\frac{5}{32}$ [13]	965-1155 [518-624]	3	3	3	3	yes	4	1	2	1	3	4	1	4	no



## SUMMARY OF CHANGES

Committee B07 has identified the location of selected changes to this standard since the last issue (B 108 – 01a) that may impact the use of this standard. (Approved June 10, 2003.)

- |   |  |
|---|--|
| <p>(1) Replaced reference to Practice B 597 with reference to Practice B 917/B 917M.</p> <p>(2) Added new paragraph 1.2.</p> <p>(3) Revised paragraphs 11.3 and 17.1.</p> <p>(4) Updated the Referenced Documents section.</p> <p>(5) Added Terminology B 881 to Referenced Documents and to paragraph 3.1.</p> <p>(6) Removed alloys 208.0, 213.0, and 222.0 from Table 1,</p> | <p>Table 2, and Table X1.1 and placed them in “Inactive Alloys” tables in X3.1.</p> <p>(7) Removed MIL-STD-278 from 18.2.1.7 and replaced with NAVSEA Technical Publication S9074-AR-GIB-010/278.</p> <p>(8) Removed MIL-I-13857 from 2.5 and 18.3.</p> <p>(9) Added SI units to Table X1.1 for “Approximate Melting Range.”</p> |
|---|--|

*ASTM International takes no position respecting the validity of any patent rights asserted in connection with any item mentioned in this standard. Users of this standard are expressly advised that determination of the validity of any such patent rights, and the risk of infringement of such rights, are entirely their own responsibility.*

*This standard is subject to revision at any time by the responsible technical committee and must be reviewed every five years and if not revised, either reapproved or withdrawn. Your comments are invited either for revision of this standard or for additional standards and should be addressed to ASTM International Headquarters. Your comments will receive careful consideration at a meeting of the responsible technical committee, which you may attend. If you feel that your comments have not received a fair hearing you should make your views known to the ASTM Committee on Standards, at the address shown below.*

*This standard is copyrighted by ASTM International, 100 Barr Harbor Drive, PO Box C700, West Conshohocken, PA 19428-2959, United States. Individual reprints (single or multiple copies) of this standard may be obtained by contacting ASTM at the above address or at 610-832-9585 (phone), 610-832-9555 (fax), or [service@astm.org](mailto:service@astm.org) (e-mail); or through the ASTM website ([www.astm.org](http://www.astm.org)).*