



Standard Practices for Packaging/Packing of Aluminum and Magnesium Products¹

This standard is issued under the fixed designation B 660; the number immediately following the designation indicates the year of original adoption or, in the case of revision, the year of last revision. A number in parentheses indicates the year of last reapproval. A superscript epsilon (ϵ) indicates an editorial change since the last revision or reapproval.

This standard has been approved for use by agencies of the Department of Defense.

1. Scope *

1.1 These practices describe methods of packaging/packing aluminum and magnesium products, in preparation for storage or shipment, both foreign and domestic. Assuming proper and normal handling in transit, these practices are designed to deliver the products to their destination in good condition. For DoD redistribution, see Supplementary Requirements.

1.2 Aluminum and magnesium products must be preserved and packed so as to be adequately protected from possible damage during shipment and storage. Major damage types are:

1.2.1 Mechanical, including bending, crushing, denting, scratching, or gouging during handling and storage; and abrasions resulting from vibration during transport of the material.

1.2.2 Corrosion, or water stain, resulting from exposure of packed material to water, either externally applied, or as condensate caused by temperature variations in a humid atmosphere.

NOTE 1—A complete metric companion to Practices B 660 is being developed—Practices B 660M; therefore, no metric equivalents are presented in these practices.

1.3 *This standard does not purport to address all of the safety concerns, if any, associated with its use. It is the responsibility of the user of this standard to establish appropriate safety and health practices and determine the applicability of regulatory limitations prior to use.*

2. Referenced Documents

2.1 ASTM Standards:

D 779 Test Method for Water Resistance of Paper, Paperboard, and Other Sheet Materials by the Dry-Indicator Method²

D 1732 Practices for Preparation of Magnesium Alloy Surfaces for Painting³

D 1974 Practice for Methods of Closing, Sealing, and

Reinforcing Fiberboard Boxes²

D 3950 Specification for Strapping, Nonmetallic (and Joining Methods)²

D 3951 Practice for Commercial Packaging²

D 3953 Specification for Strapping, Flat Steel and Seals²

D 4727/D 4727M Specification for Corrugated and Solid Fiberboard Sheet Stock (Container Grade) and Cut Shapes²

D 5168 Practice for Fabrication and Closure of Triple-Wall Corrugated Fiberboard Containers²

D 5486/D 5486M Specification for Pressure-Sensitive Tape for Packaging, Box Closure, and Sealing²

F 1667 Specification for Driven Fasteners: Nails, Spikes and Staples⁴

2.2 ANSI Standard:

ANSI/AHA A135.4 Basic Hardboard⁵

2.3 Federal Specifications:⁶

A-A-1249 Paper, Wrapping, Tissue

A-A-1671 Tape, Gummed (Paper, Reinforced, Asphalt Laminated)

A-A-55057 Panels, Wood/Wood-Based; Construction and Decorative

PPP-B-566 Box, Folding, Paperboard

PPP-C-96 Can, Metal, 28 Gage and Lighter

PPP-D-705 Drum, Shipping and Storage: Steel 16 and 30 Gallon Capacity

PPP-D-723 Drum, Fiber (inactive for new design)

PPP-D-729 Drum, Shipping and Storage: Steel, 55 Gallon

PPP-P-704 Pails, Metal: (Shipping, Steel, 1 through 12, Gallons)

PPP-T-495 Tubes, Mailing, and Filing

2.4 Federal Standards:⁶

APA-PS1 U.S. Product Standard (For Construction and Industrial Plywood)

FED-STD-101 Preservation, Packaging and Packing Materials: Test Procedure

2.5 Military Specifications:⁶

¹ These practices are under the jurisdiction of ASTM Committee B07 on Light Metals and Alloys and are the direct responsibilities of Subcommittee B07.03 on Aluminum Alloy Wrought Products.

Current edition approved Oct. 10, 2002. Published January 2003. Originally published as B 660 – 79. Last previous edition B 660 – 96 (2002).

² *Annual Book of ASTM Standards*, Vol 15.09.

³ *Annual Book of ASTM Standards*, Vol 02.05.

⁴ *Annual Book of ASTM Standards*, Vol 01.08.

⁵ Available from American National Standards Institute, 25 W. 43rd St., 4th Floor, New York, NY 10036.

⁶ Available from Standardization Documents Order Desk, Bldg. 4 Section D, 700 Robbins Ave., Philadelphia, PA 19111-5098, Attn: NPODS.

*A Summary of Changes section appears at the end of this standard.

- MIL-C-11796 Corrosion Preventive Compound, Petroleum, Hot Application
MIL-P-17667 Paper, Wrapping, Chemically Neutral (Non-Corrosive) (inactive for new design)
MIL-PRF-121 Barrier Materials, Greaseproof, Waterproof, Flexible, Heat-Sealable
MIL-PRF-16173 Corrosion Preventive Compound, Solvent Cutback, Cold Application
MIL-PRF-32033 Lubricating Oil, General Purpose, Preservative (Water Displacing, Low Temperature)
MIL-PRF-7870 Lubricating Oil: General Purpose, Low Temperature
2.6 *Military Standard:*⁶
MIL-STD-129 Marking for Shipment and Storage
2.7 *Other Standards:*⁷

Aluminum Standards and Data-Protective Oil for Aluminum

3. Classification

3.1 *Levels of Protection*—The following levels of protection apply equally to preservation and packing.

3.1.1 *Level A*—The degree required for protection against the most severe conditions known or anticipated to be encountered during shipment, multiple rough handling, and intransit storage.

3.1.2 *Commercial Packaging*—The degree required for protection of material during shipment from supplier to user for immediate use or limited storage in a dry, heated storage facility. The methods and materials employed by the supplier to satisfy the requirements of the commercial distribution system to provide protection against corrosion, deterioration, and damage during shipment to a user may be used.

⁷ Available from The Aluminum Association, 900 19th St., NW, Washington, DC 20006.

TABLE 1 Packaging (Preservation) and Packing for Level A (Note—For Commercial Packaging, See Section 8)

Product	Preservation (6.1.1)	Packing (Section 7) for Barrier, see Table 2	Maximum ^A Net Weight Per Container (7.17)
Bar, rod and wire (cold-finished, drawn, extruded, rolled, and forged):			
Coiled, bare	AL-oiled, Mg-Chrome pickled (6.1.1.1-6.1.1.3)	Wrapped coils (Fig. 1). Wrap with one layer of Type IIB barrier.	120
Coiled, covered	none required	Wrapped coils (Fig. 1). Wrap with one layer of Type IIB barrier.	120
Spooled for military requirements: 5, 10, 15, 20, 30, lb per spool (other: standard commercial weights)	none required	Wooden boxes (Figs. 2-5). Boxes shall be case-lined with one layer of Type IIA barrier or two layers of Type III barrier.	300
Straight lengths	AL-oiled, Mg-Chrome pickled (6.1.1.1-6.1.1.3)	Wooden boxes (Figs. 6-8). Boxes shall be case-lined with one layer of Type IIA barrier or two layers of Type III barrier.	1000 ^B
		or	
		Corrugated fiberboard boxes, Class weather-resistant (S6.1)	300
		or	
		Fiber-drums (7.14)	200
Blooms and billets	See ingot
Bus conductors (cold-finished, drawn, extruded and rolled)	See bar, straight lengths
Cable (bare and covered):			
Size 1/0 and smaller	none required	Wrapped coils (Fig. 1). Wrap with one layer of Type IIB barrier.	(bare) 250 (covered) 200
		or	
		Reels (Fig. 9).	(bare) 1250 (covered) 1000
Size larger than 1/0	none required	Reel (Fig. 9).	(bare) 1600 (covered) 1300
Casting and forgings, finished.	none required	Wooden boxes (Figs. 2-5) or Style Fig. 10). Boxes and crates shall be case lined with one layer of Type IIA barrier or two layers of Type III barrier.	2000
Castings and forgings, rough	none required	Bare bundles (Fig. 11).	1000
Conduit	See ANSI schedule pipe.
Extruded profiles (metal less than 1 lb per linear foot) ^C	AL-oiled, Mg-Chrome-pickled (6.1.1.1-6.1.1.3)	Wooden boxes (Figs. 6-8). Boxes shall be case lined with one layer of Type IIA barrier	2000
		or	
Fittings (pipe and conduit)	AL-oiled, Mg-Chrome-pickled (6.1.1.1-6.1.1.3)	Corrugated fiberboard boxes, Class weather-resistant (S6.1)	300
		or	
	External threads shall be covered with suitable thread protectors.	Wooden boxes (Figs. 2-5) or Style 1 crate (Fig. 10) dependent upon size of fittings. Boxes and crates shall be case lined with one layer Type IIA barrier.	100

Foil^{D,E}

TABLE 1 *Continued*

Product	Preservation (6.1.1)	Packing (Section 7) for Barrier, see Table 2	Maximum ^A Net Weight Per Container (7.17)
Coiled	Foil shall be wound on aluminum fiber or steel cores. End of coil shall be secured with pressure sensitive tape. Sheared edges shall be protected from flanges and adjacent coils with suitable edge protectors. Each coil, or coils (see 7.10) shall be wrapped with aluminum 0.001 in. thick aluminum foil.	Wooden boxes (Figs. 2-5). Coils shall be suspended by extended cores or wood dowels through the core. Core extension or dowel shall be inserted in wood flanges so that periphery of coil does not contact inner surface of box (Fig. 12). Minimum flange thickness shall be as specified in 7.10.	500
	Foil wrap shall be a conformable wrap completely enclosing the coil or coils and edge protectors on each core or dowel (Fig. 12).	Corrugated fiberboard boxes, Class weather-resistant (S6.1) suspended as above.	300
Flat	none required	Wooden boxes (Figs. 2-5). Contents shall be wrapped with one separate layer of Type IIA barrier.	500
		or Corrugated fiberboard boxes, Class weather-resistant (S6.1)	300
Forgings	See castings	...	
Forging stock	See bar	...	
Impact extrusions	none required	Wooden boxes (Figs. 2-5). Boxes shall be lined with one layer of Type IIA barrier.	700
		or Corrugated fiberboard boxes, Class weather-resistant (S6.1)	300
Ingots:	500 lb per piece and over	Loose	...
	30–500 lb per piece	Bare bundles (Fig. 13). Size of bundle straps shall be as shown in Table 3. A minimum of two straps shall be used per bundle.	3500
	Less than 30 lb per piece	Pallets (Fig. 14). Size pallet straps shall be as shown in Table 3. or Self-palletized bundle. Interlocking ingots that are self-palletized may be shipped in strapped bundles not over 42 in. high. Bundle shall be strapped with a minimum of one ¾-in. steel strap.	2500 1500
Grained and granulated ingot and shot	Product to be packed in wood boxes (Figs. 2-5), shall be packaged in Federal Specification PPP-B-566, boxes, folding, paperboard.	Wooden boxes (Figs. 2-5)	500
		or Federal Specification PPP-P-704 Steel Pails (7.12). Pails shall not be overpacked.	70
		or Federal Specification PPP-D-705 and PPP-D-729 Steel Drums (7.13). Drums shall not be overpacked.	650
		or Federal Specification PPP-D-723 Fiber Drums (7.15). Drums shall not be overpacked.	550
Paste and powder	Product to be packed in wooden boxes (Figs. 2-5) shall be packaged in 1, 2, or 10 lb friction top can in accordance with Federal Specification PPP-C-96, Type V, Class 2.	Wooden boxes (Figs. 2-5).	50
		or Federal Specification PPP-D-705 or PPP-D-729 Steel Drums (7.13). Drums shall not be overpacked.	600
Plate: ^F			
Flat and tapered	Al see Table 4, Mg see Table 5.	Pallets (Figs. 15-18) with pallet enclosures (Fig. 19, Fig. 20, and Fig. 21). Contents shall be wrapped with one layer of Type IIA barrier or two layers of Type III barrier.	4000
Circles	Al see Table 4, Mg see Table 5.	Pallets (Figs. 15-18) with pallet enclosures (Fig. 19, Fig. 20, and Fig. 21). Contents shall be wrapped with one layer of Type IIA barrier or two layers of Type III barrier.	4000
Floor and tread	none required	Pallets (Figs. 15-18). Secure contents to pallet with minimum two lengthwise and two girthwise straps, size 1¼ by 0.031 in.	10 000
Plate and abrasive			
Tread plate			
Screw machine stock	See bar	...	
Sheet: ^G			
Flat and tapered			

TABLE 1 *Continued*

Product	Preservation (6.1.1)	Packing (Section 7) for Barrier, see Table 2	Maximum ^A Net Weight Per Container (7.17)
90 lb per piece or less or 15 ft in length or less	Al see Table 4, Mg see Table 5.	Pallet enclosure (Fig. 21) Contents of box shall be wrapped with two layers of Type IIA barrier or one layer of Type IIA barrier and one layer of Type III barrier.	4000 (Not to exceed 200 sheets)
Over 90 lb per piece or over 15 ft in length	Al see Table 4, Mg see Table 5.	Pallets (Figs. 15-18) with pallet enclosures (Fig. 19 and Fig. 20). Contents shall be wrapped with two layers of Type IIA barrier.	4000
Coiled	Al-coiled, Mg-Chrome-pickled (6.1.1.1-6.1.1.3)	Pallets (Figs. 15-18) with pallet enclosure (Fig. 20). Contents shall be wrapped with one layer of Type IIA barrier or two layers of Type III barrier.	4000
Roofing and siding	none required	Pallets (Figs. 15-18) with pallet enclosures (Fig. 19 and Fig. 20). Contents shall be wrapped with one layer of Type IIA barrier.	4000
Structural profiles (extruded and rolled) ^G Less than 150 lb per piece	Al-none required. Mg-Chrome-pickled.	Wooden boxes (Figs. 6-8). Boxes shall be case lined with one layer of Type IIA barrier or two layers of Type III barrier. or Corrugated fiberboard boxes, Class weather-resistant (S.1.7.1)	1000 300
150 lb per piece and over Tubular products (drawn, extruded, and welded): Coiled	Al-none required. Mg-Chrome-pickled. Al-oiled, Mg-oiled (6.1.1.1-6.1.1.3). Stagger wound coils shall be tied through the core in two places with twine or pressure sensitive tape. Pancake or level layer would coils shall not be tied.	Loose Style 1 crates (Fig. 10). Crates shall be case lined with one layer of Type IIA barrier.	... 700
Straight lengths	Al-oiled, Mg-Chrome-pickled (6.1.1.1-6.1.1.3). When the wall thickness of tube is less than 2½ % of the outside diameter, boxes shall be lined with suitable cushioning material.	Wooden boxes (Figs. 6-8). Boxes shall be case lined with one layer of Type IIA barrier, or Corrugated fiberboard boxes Class weather-resistant (S6.1). or Fiber tubes (7.16).	300 200
ANSI schedule pipe	Al-no preservative required. Mg-Chrome pickled (6.1.1.1-6.1.1.3). External threads shall be covered with suitable protectors.	Wooden boxes (Figs. 6-8). Boxes shall be case lined with one layer of Type IIA barrier or two layers of Type III barrier. or Style 2 and 3 crates Fig. 22 to Fig. 23). Crates shall be case lined with one layer of Type IIA barrier. or Fiber tubes (7.16).	800 4000 200
Construction pipe	Al-no preservative required. Mg-Chrome pickled (6.1.1.1-6.1.1.3).	Same as for ANSI scheduled pipe above.	See Packing
Welding and brazing rod Coiled	none required	Wrapped coils (Fig. 1). Wrap with one layer of Type IIA barrier or two layers of Type III barrier.	120
Straight lengths, 36 in.	Package 5 lb per fiber tube with metal ends or 10 lb per fiberboard carton. 10 fiber tubes or 8 cartons shall be overpacked in a weather-resistant fiberboard carton in accordance with Practice D 1974. All corners and seams of boxes, including manufacturer's joint, shall be sealed with Specification D 5486/D 5486M, Type III or IV, Class 1, minimum 2 in. wide tape.	Wooden boxes (Figs. 2-5). Fiberboard boxes shall be overpacked in wooden boxes.	1000

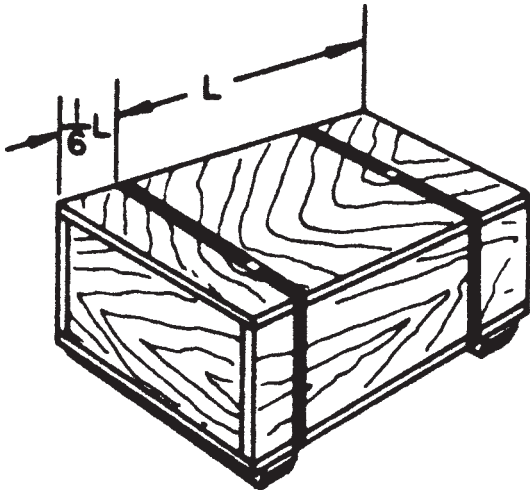

FIG. 2 Style 1 Nail Wood Box^A

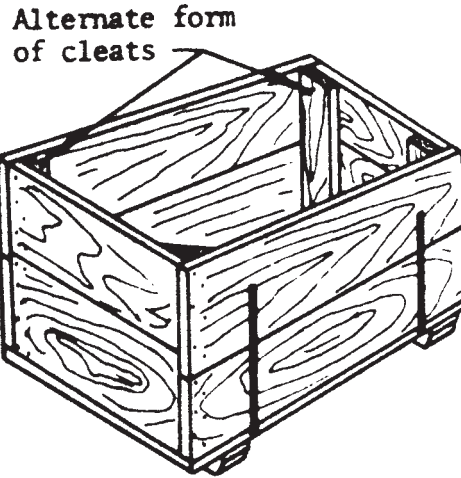

FIG. 5 Style 5 Nail Wood Box^A

^A These boxes are for: (1) Grained and granulated ingot and shot; (2) Paste and powder; (3) Fittings—(pipe and conduit); (4) Spooled bar, rod, wire; (5) Castings and forgings, finished; (6) Foil, coiled and flat; (7) Impact extrusions; (8) Welding and brazing rod, straight; and (9) Inert gas welding electrodes.

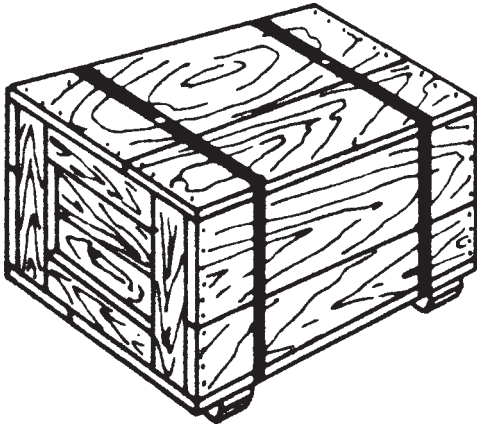

FIG. 3 Style 2 Nail Wood Box^A

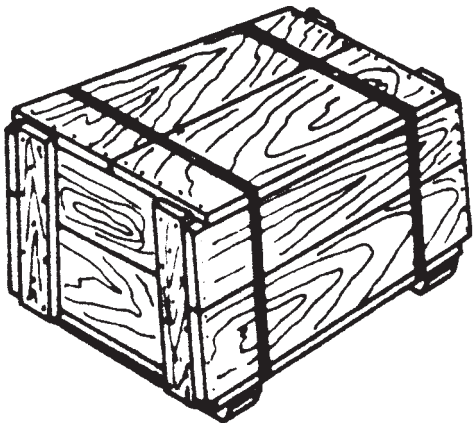

FIG. 4 Style 4 Nail Wood Box^A

4.1.5 *gross weight*—bare item weight and the weight of all packaging and packing materials.

4.1.6 *header*—member of skid-type base used to join the ends of two or more skids and provide added strength to the base.

4.1.7 *interleaving*—placement of a sheet of protective material between two adjacent pieces of metal.

4.1.8 *net weight*—bare item weight.

4.1.9 *nominal*—referring to lumber size, rough sawn commercial size of soft wood lumber common to the industry.

4.1.10 *splice*—to unite or join the ends of material such as lumber, plywood, or paper overlaid veneer.

4.1.11 *tension tied*—seurement applied with mechanical tools.

5. General Requirements

5.1 *Materials, Methods, and Containers*—Materials, methods, and containers shall conform to the requirements of this standard. Those exceeding the requirements may be substituted as negotiated by purchaser and producer or supplier.

5.1.1 Materials not covered by applicable specifications or not specifically described herein shall be of high quality and shall be compatible with and protect the contents.

5.1.2 *Splicing Requirement*—When container members must be spliced to obtain the required length or width, the adjacent edges of the two pieces being spliced shall be butt-jointed as specified in 5.1.2.1 and each piece fastened to the splice board. The fastening shall conform to the requirements specified for construction of the panels being spliced. Nails must be clinched.

5.1.2.1 Splice boards shall be applied to extend on each side of the joint at least two times the width of and the same thickness as the box boards.

5.1.3 The inside dimensions of boxes shall be commensurate with the size of the item.

5.2 Internal Packaging Materials:

5.2.1 *Material Compatibility*—Internal packaging materials shall not adversely affect the contents.

5.2.2 *Blocking and Bracing*—Articles not completely filling the shipping container shall be blocked, braced, fastened, or otherwise secured. Articles having projecting parts that may be

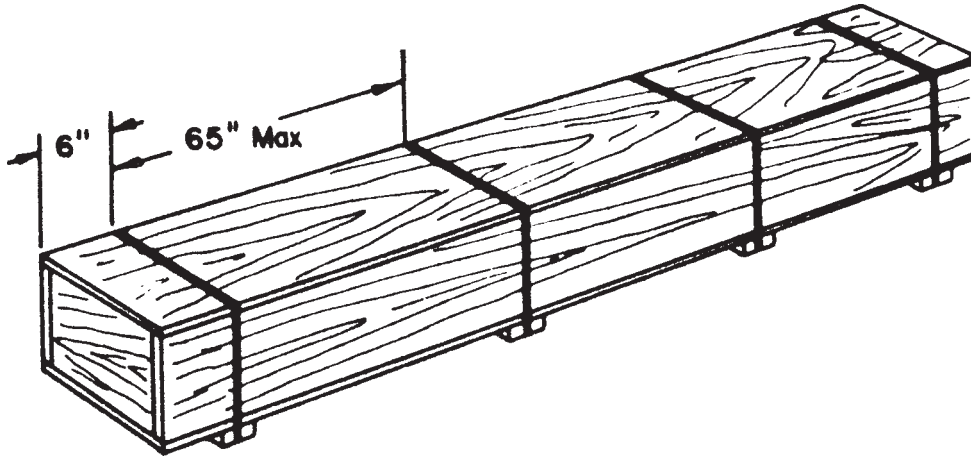

FIG. 6 Style 1 Nail Wood Box^B

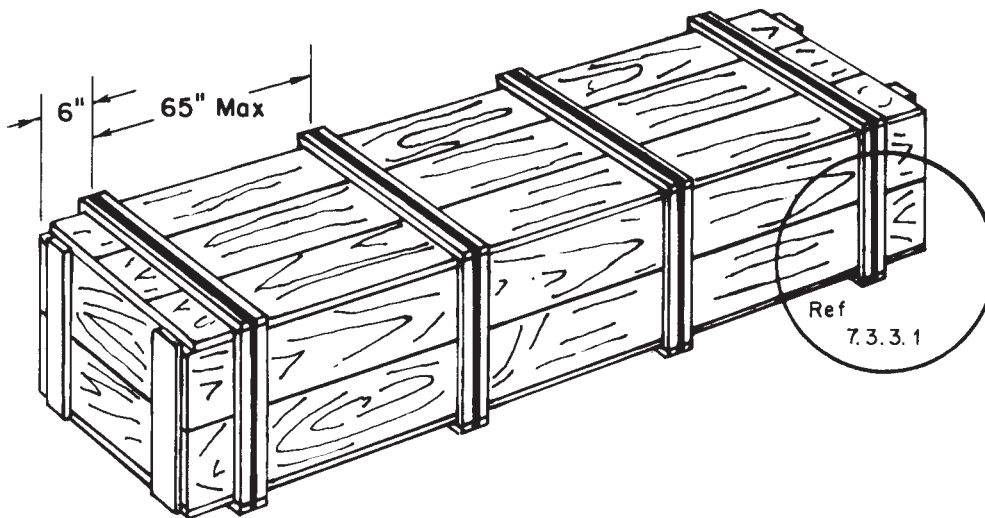

FIG. 7 Style 4 Nail Wood Box^B

broken or may puncture the container shall be rigidly supported, suspended, or otherwise protected. Clearance of at least 1 in. shall be provided between projecting parts and the adjacent inside face of the container. Blocking and bracing shall be prevented from coming in direct contact with any unprotected surface of the item by use of suitable cushioning material.

5.3 Handling:

5.3.1 General—Containers and pallets in their shipping configuration shall be provided with lifting and hoisting provisions commensurate with their weight, size, and intended mode of transportation to ensure safe and efficient movement.

5.3.2 Hoisting—Convenient means shall be provided on all shipping containers (except Fig. 24, Fig. 25, Fig. 26, and Fig. 27) and pallets weighing more than 200 lb gross which will permit hoisting by attaching suitable slings at the bottom of the containers and pallets.

5.3.3 Forklift Truck Compatibility—Unless otherwise specified herein and except Fig. 24, Fig. 25, Fig. 26, and Fig. 27,

boxes, containers, and pallets grossing over 200 lb must be capable of being handled from at least two sides by forklift trucks. For DoD use, standard 40 by 48 in. pallets must have four-way forklift entry. Openings shall be a minimum of 3 in. high and at least 20 in. apart inside-to-inside, symmetrically about the center of balance. Containers may have a single opening 40 in. wide or more to provide forklift access.

6. Detailed Requirements

6.1 Packaging Preservation—Packaging shall be Level A, or commercial preservation as follows:

6.1.1 Level A—Detailed requirements for packaging (preservation) of aluminum and magnesium products are listed alphabetically by product in Table 1. When Level A is specified, items shall be preserved in accordance with the detailed requirements outlined herein.

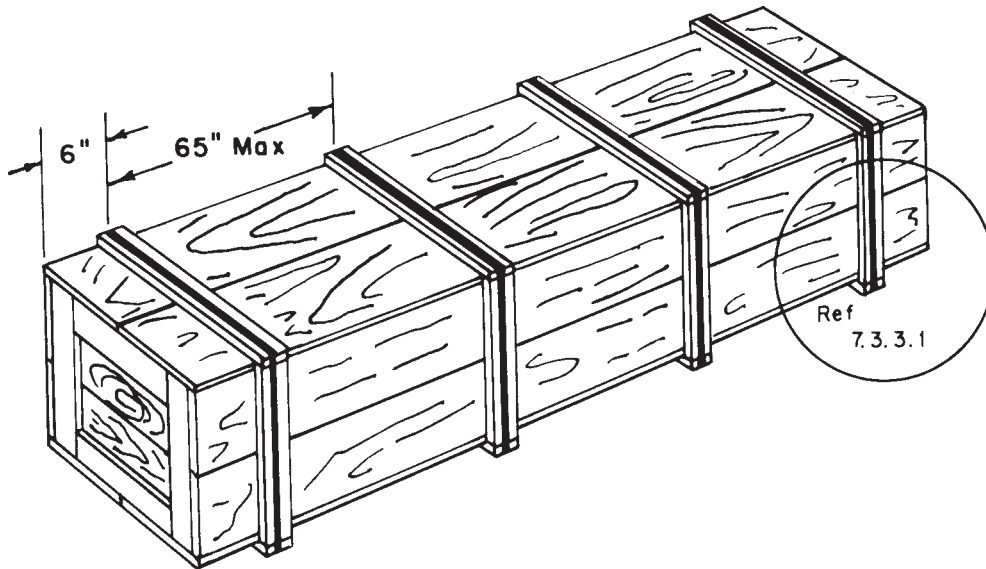

FIG. 8 Style 2 Nail Wood Box^B

^B For Bar, Rod, Shapes, Tubular Products and Wire

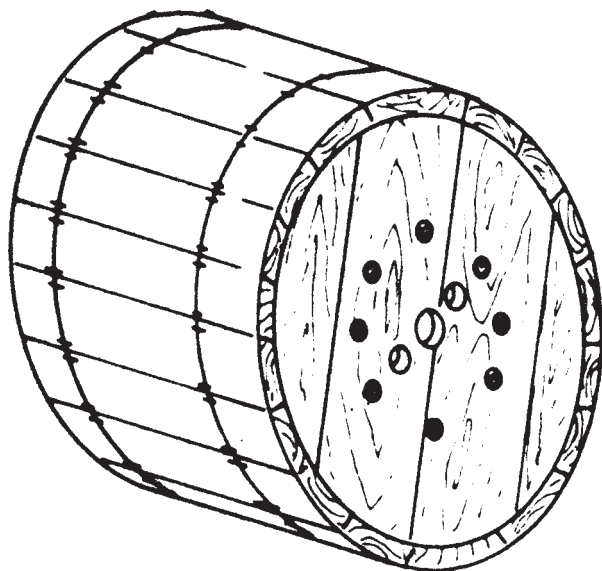

FIG. 9 Lagged Reel (Export Reel)¹

¹ For cable.

6.1.1.1 *Cleanliness*—Surfaces shall be commercially clean, and free from loose mill scale, dirt, foreign matter, or corrosion. The presence of residual rolling oil shall not be considered foreign matter.

6.1.1.2 *Preservatives*—Oil used for preservation of aluminum products shall conform to the requirements of Aluminum Standards and Data—Protective Oil for Aluminum, MIL-PRF-32033 or MIL-PRF-7870. Oil used for preservation of magnesium products shall conform to the requirements of MIL-PRF-16173, Grade 2, or MIL-C-11796, Class 3. Chrome pickle treatment of magnesium products shall conform to the requirements of Practices D 1732.

6.1.1.3 *Application of Preservative Coating*—The application of corrosion-preventive material demands careful attention; compounds shall not be applied to surfaces that show

signs of moisture, condensation, frost, dirt, or other contaminants. The maximum corrosion resistance is obtained only by a thorough coating of a contaminant-free surface. It is essential that articles treated are not unduly handled until film is set. Application may be by dipping, brushing, rolling, spraying, or flowing onto the surface.

6.1.1.4 *Interleaving*—The interleaving paper shall fully cover the metal; for manual application, paper shall extend 1 in. beyond sides and ends, for machine application, paper may be same size as the metal provided the metal is fully covered.

6.1.1.5 *Wraps*—Application of wraps shall be in accordance with Table 1. Products may be machine-wrapped or hand-wrapped.

6.1.2 *Commercial Preservation*—When commercial preservation is specified, items will be given the degree of protection normally employed by the supplier against corrosion, deterioration, and damage during shipment.

6.2 *Material Requirements:*

6.2.1 *Fiberboard*—Fiberboard for boxes and liners shall conform to the requirements of Specification D 4727/D 4727M, class weather-resistant.

6.2.2 *Paper and Barrier Material*—Paper and barrier material shall conform to the requirements of Table 2.

6.2.3 *Wood*—The species of wood indicated in Table 6 and classified into groups as shown shall be used. The groups are set up to include, in any one group, species of woods that have approximately similar characteristics important to box design. These characteristics include density, flexural and compressive strength, stiffness, shock absorption, and nailholding power. When any species of wood is specified, any one or more species in the same group may be used. Groups I and II may be interchanged. Groups III and IV may be interchanged.

6.2.4 *Lumber*—All lumber dimensions used in these practices are nominal sizes except where minimum sizes are specified. At least one surface, which is to be placed on the outside of boxes, crates, or pallet closures, shall be sufficiently smooth to permit legible marking, stenciling, or printing.

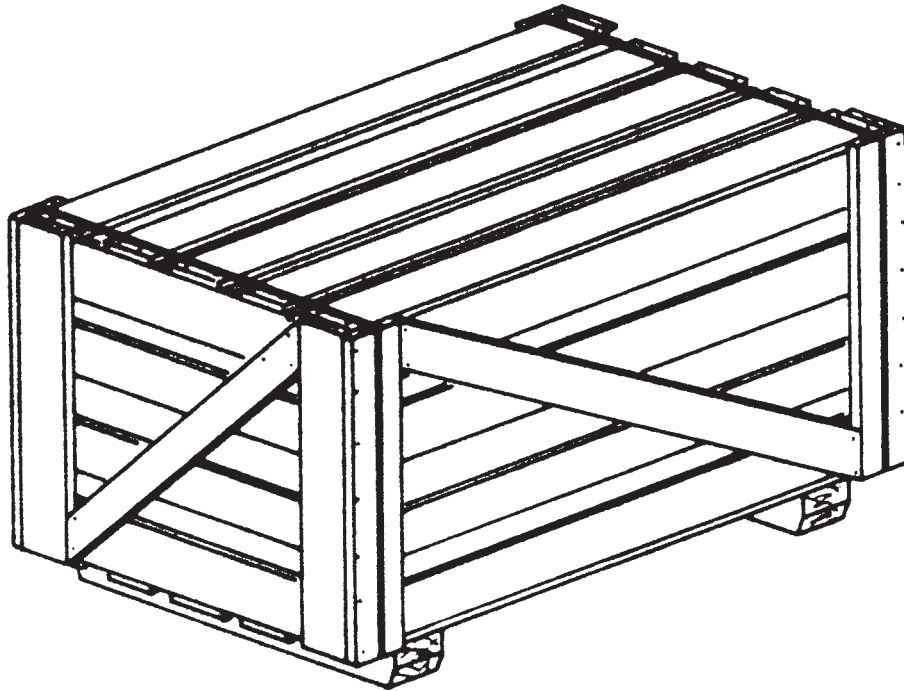

FIG. 10 Style 1 Crate, Open^F
^F For castings, fittings, and coiled tube.

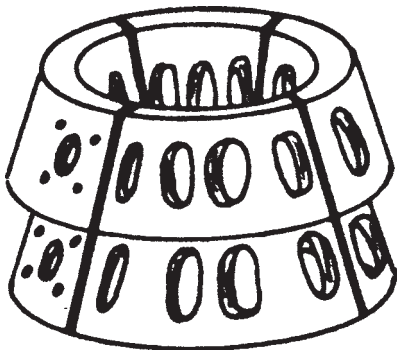

FIG. 11 Strapped Bundle for Castings and Forgings

Pieces shall be cut true to length. The boards shall be free of defects that materially weaken them, expose the contents of the box to damage, or interfere with the prescribed fabrication or nailing.

6.2.5 *Plywood*—Unless otherwise specified, plywood used to fabricate cleated panels shall conform to Federal Specification Product Standard APA-PS1 and Federal Specification A-A-55057, standard interior (Grade C-D) with exterior glue.

6.2.6 *Hardboard*—Unless otherwise specified, hardboard shall be in accordance with ANSI/AHA A135.4. When appropriate, hardboard or other composite boards may be used in lieu of plywood for panel stock provided that they are weather resistant and are so sized that they will perform to the same level as plywood.

6.2.7 *Nails and Staples*—Nails and staples shall conform to Specification F 1667 or equivalent. All unclinchd nails shall be cement-coated or chemically etched, except for Style 18 (spiral-shanked) and ring-shanked nails which are also acceptable.

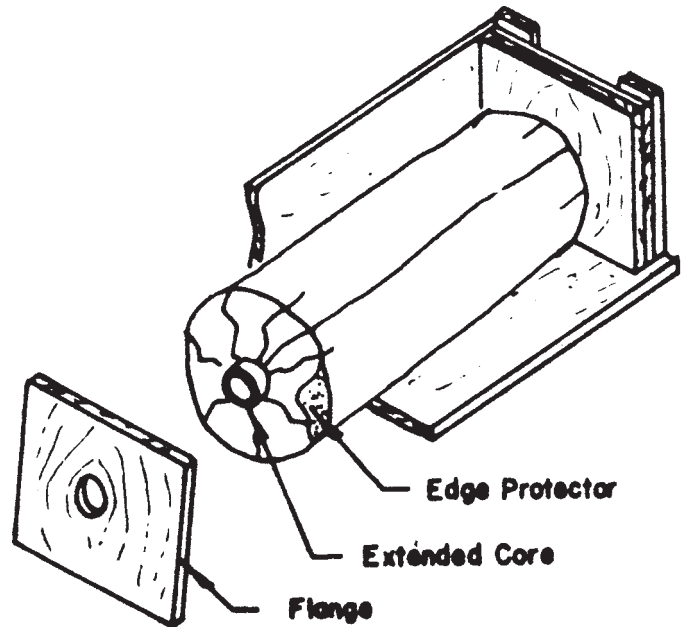

FIG. 12 Coil Foil Packing (See 7.9)

6.2.8 *Strapping*—Flat steel strapping shall conform to Specification D 3953, Type 1, Finish A. Equivalent nonmetallic strapping conforming to Specification D 3950 may be used when comparable strength requirements are satisfied.

6.2.9 *Tapes*—Tapes shall conform to the requirements of Federal Specifications A-A-1671 or Specification D 5486/D 5486M as applicable.

6.3 *Packing*—Packing shall be Level A or commercial packing in accordance with Sections 7 and 8.

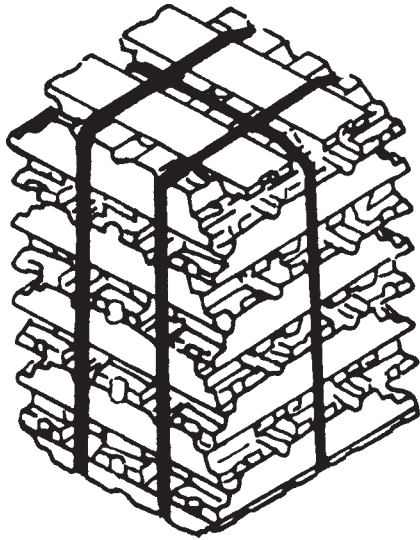

FIG. 13 Strapped Bundle for Ingot (See 7.7)

TABLE 3 Strap Sizes for Boxes and Bundles (6.2.8) (Figs. 2-8, Fig. 1, Fig. 11, Fig. 14, and Fig. 13)

Type of Package	or	Weight of Contents, lb	Flat Steel Strapping, in.
Pallets	...	Less than 700	5/8 by 0.020
...		700 to 2000	3/4 by 0.023

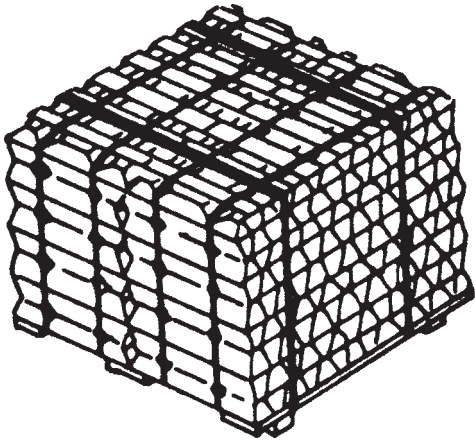

FIG. 14 Pallet for Ingot (See 7.7)

NOTE 2—Only one type, class, or size of material shall be packed in a single container.

7. Level A Packing

7.1 General—When Level A is specified in the contract or order, items shall be packed in accordance with the requirements in Table 1. When Table 1 provides a choice of several containers for a particular product, any one of the containers may be selected for use, unless specifically prohibited by the contract or order. This section provides requirements applicable to packing procedures and construction details for containers and methods not covered by specification reference.

TABLE 4 Preservation of Aluminum Sheet and Plate (See Table 1)

Product	Preservation ^{A,B}
Abrasive tread plate	None required
Flat and tapered sheet and plate, and all circles:	
Clad, all alloys:	None required
Circles less than 12 in. in diameter	
Flat, tapered and circles 12 in. in diameter and over	Interleaved
Nonclad:	
Circles less than 12 in. in diameter	None required
Flat, tapered and circles 12 in. in diameter and over:	
Heat-treatable alloys, all tempers ^B	Oiled (6.1.1.1-6.1.1.3) ^C
Non-heat-treatable alloys: ^B	
Annealed	Interleaved (6.1.1.4)
Other than annealed:	
0.060 in. thick and over	Interleaved (6.1.1.4)
Less than 0.060 in. thick	Oiled (6.1.1.1-6.1.1.3) ^C
Painted, chemical conversion coated, and anodized sheet and plate	Interleaved (6.1.1.4)
Floor and tread plate	None required
Coiled sheet	Oiled (6.1.1.1-6.1.1.3) ^C
Perforated sheet	Oiled (6.1.1.1-6.1.1.3) ^C
Roofing and siding sheet	None required

^A Interleaving paper shall be Type 1 paper (Table 2). For metal 0.090 in. thick and less interleaving paper shall be minimum 10-lb basis weight; for metal over 0.090 in. thick interleaving paper shall be minimum 15-lb basis weight.

^B Heat-treatable alloys are the 2000, 6000, and 7000 groups. Non-heat-treatable alloys are the 1000, 3000, and 5000 groups.

^C For other than DOD requirements, oil at mill option.

TABLE 5 Preservation of Magnesium Sheet and Plate (See Table 1)

Product	Preservation ^{A,B}
Flat sheet and plate:	
Less than 0.005 in. thick	Oiled (6.1.1.1-6.1.1.3) or Oiled and interleaved (6.1.1.1-6.1.1.4) or Chrome-pickled and interleaved
0.005 in. and thicker	None or Oiled (6.1.1.1-6.1.1.3)

^A Interleaving paper shall be as specified for aluminum sheet and plate (Table 4 Footnote A).

^B Preservation desired must be as specified in the contract or order.

7.2 Boxes (Figs. 2-8)—When required by Table 1, boxes shall be constructed as follows:

7.2.1 Top and Bottom Panels—Top and bottom panels shall consist of a complete covering of lumber. Panels for boxes, Figs. 2 and 6, shall be without cleats. Panels for boxes, Fig. 7 and Fig. 8, shall be with cleats. Thickness of panels shall be in accordance with Table 7.

7.2.2 Side and End Panels—Side and end panels shall consist of a complete covering of lumber, unless otherwise specified. Thickness and panels shall be in accordance with Table 7.

7.2.2.1 Panels for boxes, Fig. 2 and Fig. 6, 11½ in. or less in depth and not more than 16 ft long shall be of one-piece construction and without cleats, except that end panels may be two-piece, cross-grain-laminated to obtain the required thickness. Side panels more than 16 ft long may be of two-piece butt joint and splice construction (5.1.2) without cleats.

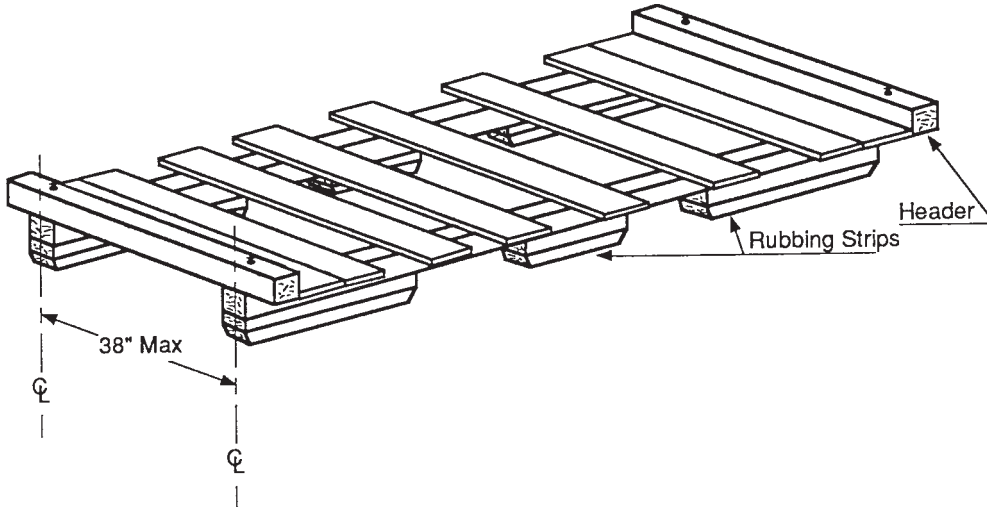

FIG. 15 Pallet with Lengthwise Skids (Runners)^C (Headers mandatory for DoD, otherwise optional)

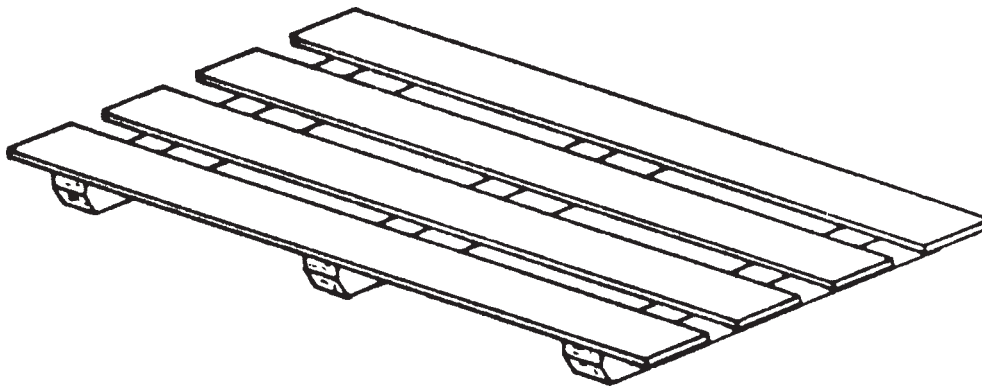

FIG. 16 Pallet with Crosswise Skids. (Runners)^C

^C For plate and plate circles; sheet, flat, or coiled. Roofing and siding.

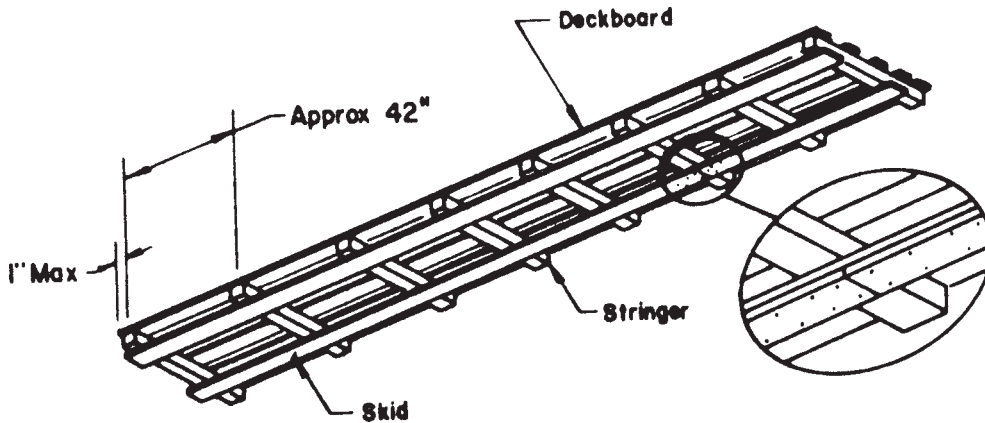

FIG. 17 Double Faced Pallet with Laminated Skids (Runners)^D

7.2.2.2 Panels for boxes, Fig. 3, Fig. 4, Fig. 5, Fig. 7, and Fig. 8, more than 11½ in. in depth shall be with cleats, except for side panels for boxes, Fig. 3, Fig. 4, and Fig. 5.

7.2.3 Cleats—When required by 7.3.2.1 and 7.3.2.2 cleats shall be in accordance with Table 7. Cleats shall be nailed or stapled.

7.2.3.1 Positioning of Cleats—Cleats for end panels, Fig. 3 and Fig. 5, shall be placed across the grain of the panel board

coverings and extend to within ⅛ in. of the inside surface of the top and bottom panels when the containers are closed. Cleats for end panels, Fig. 4, shall be placed across the grain of the panel board coverings and extend to within ⅛ in. of the outside surface of the top and bottom panels when the containers are closed. Cleats for Fig. 7 and Fig. 8 containers shall be set-in not more than 6 in. from the container ends and spaced a maximum of 65 in. apart.

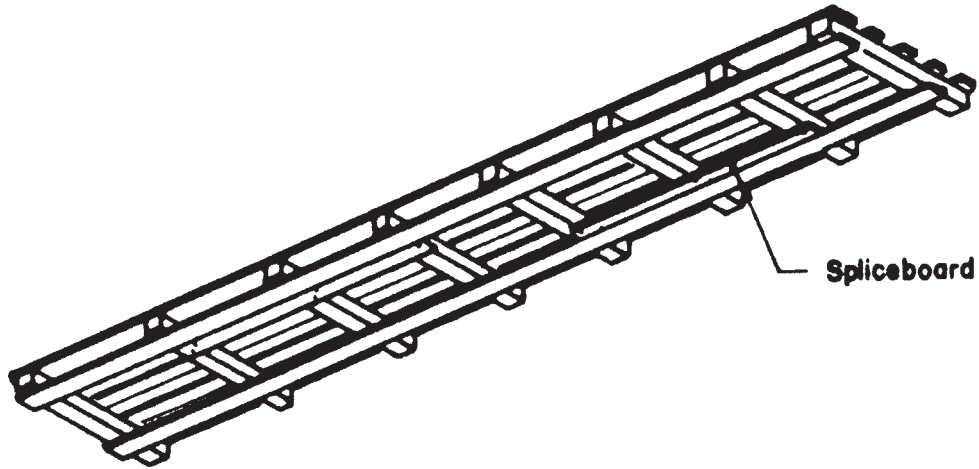

FIG. 18 Double Faced Pallet with Spliceboards^D
^D For plate and plate circles; sheet, flat, or coiled roofing and siding.

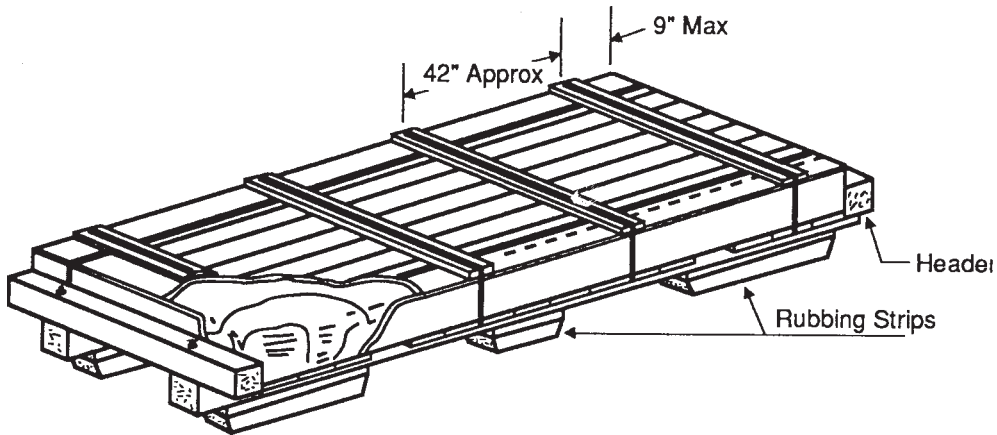

FIG. 19 Pallet Enclosure^E (Headers mandatory for DoD, otherwise optional)

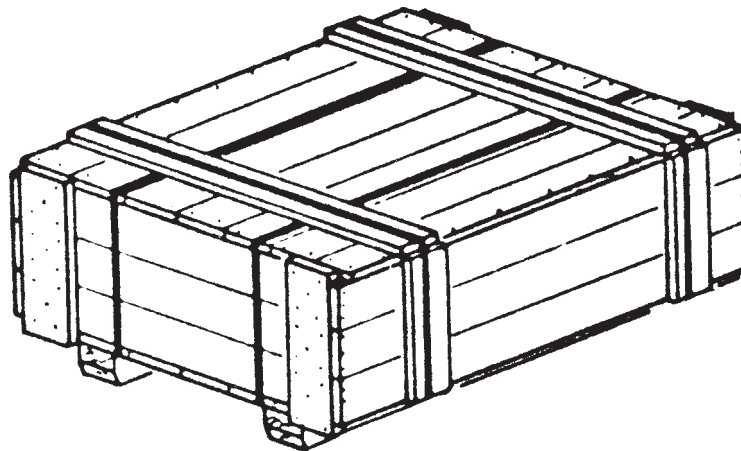

FIG. 20 Pallet Enclosure^E
^E For flat sheet.

7.2.4 *Box Skids*—Boxes with a gross weight of 200 lb (91 kg) or over shall be provided with a minimum of two nominal 4 by 4-in. skids. As an alternative, skids may be fabricated from two pieces of laminated 2 by 4-in. (nominal) lumber. Skids shall replace exterior cleats on box bottom when cleats are required. Skids shall be placed parallel to and extend the

full width of the box and shall be positioned not closer than 2½ in. nor more than one sixth the length of the box from each end of the box. The distance between skids measured between the inside edges shall not exceed 65 in. Additional skids, as required, shall be positioned so as to divide the distance between the end skids into units of equal length. The skids shall

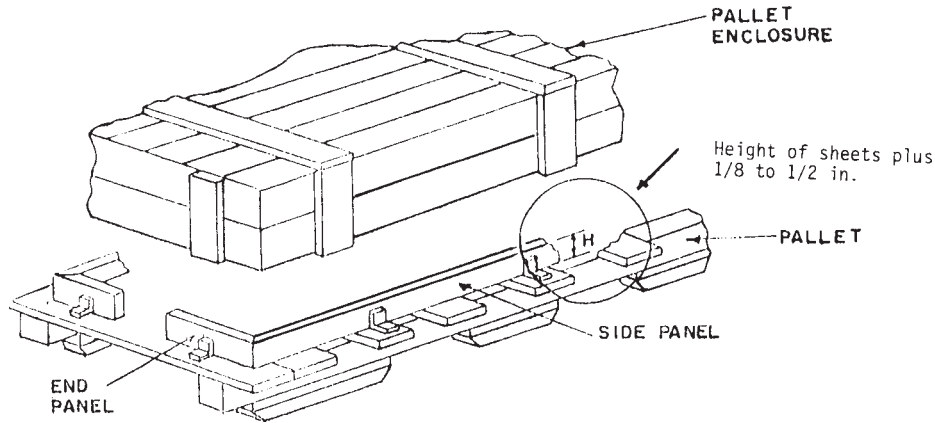

FIG. 21 Pallet Enclosure^J

^J For flat sheet, maximum net load shall be either 4000 lb or 200 sheets, whichever is reached first. Note—This figure is the same as DISC Dwg. No. 01735.

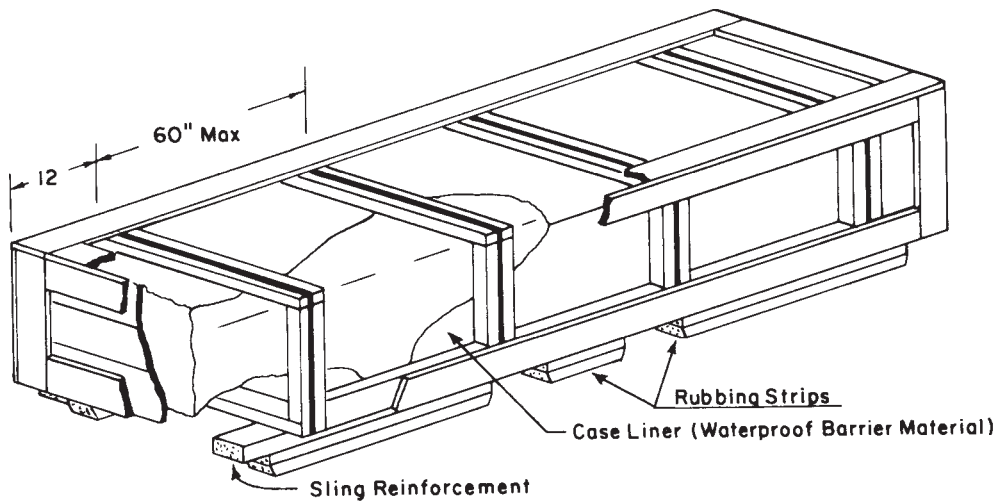

FIG. 22 Style 2 Crate, Open (Rubbing strips mandatory for DoD, otherwise optional)^G

be notched, as applicable, to provide clearance for strapping. The skids shall be secured to the box by nails specified in 6.2.7. The nails shall be driven from the inside through the bottom into the skids (in two staggered rows) and shall penetrate a minimum of $\frac{3}{4}$ the thickness of the skids. Nails conforming to Type II, screw-shanked of Specification F 1667 or equivalent ring-shanked, shall be of adequate length to penetrate a minimum of $\frac{3}{4}$ the thickness of the skids and shall not protrude through the skids. The bottom half of skid ends may be beveled at an angle of 45°.

7.2.5 *Strapping*—Size of strapping shall not be less than that shown in Table 3.

7.2.5.1 *Strap Spacing*—Straps shall be placed over all girthwise cleats. On boxes without girthwise cleats, Figs. 2 and 6, girthwise straps shall be set from each end a distance equal to one sixth the length of the box or 6 in., whichever distance is smaller, and spaced at intervals not exceeding 65 in. (Fig. 6).

7.3 *Pallet Construction* (see Figs. 28-18):

7.3.1 *Skid Ends (Runner)*, Fig. 28—Skid ends may be cut with a dado or beveled to facilitate sliding skid over an uneven surface. When straps are placed over skids, skids shall be notched out to retain strapping.

7.3.2 *Lengthwise Skids (Runners)*, Fig. 15—For pallets 52 in. wide or less, two skids shall be used and for pallets over 52 in. wide, three skids shall be used. When three skids are required, one skid shall be placed in the center of the pallet. Skids shall be fabricated from nominal 4 by 4-in. Group III or IV wood.

7.3.2.1 *Rubbing Strips*—Rubbing strips shall be added to pallets 60 in. or more in length. Rubbing strips shall be a minimum of 3 in. high by 3 in. wide, fabricated from laminated 2 by 4 in. nominal lumber and shall be attached to the skids in such a manner as to provide four way forklift entry. The bottom half of the rubbing strip shall be beveled at a 45° angle.

7.3.2.2 *Headers*—Headers are optional except for DoD shipments. When required, headers shall be fabricated from nominal 4 by 4 in. lumber and shall be bolted to skid ends with $\frac{1}{2}$ by 8 in. carriage bolts. Skids shall be of sufficient length for metal contents to be placed between the headers.

7.3.3 *Crosswise Skids (Runners)*—Fig. 16 illustrates the general arrangement for use on skids perpendicular to the deck boards. The skid dimensions shall be a minimum 3 in. high by 3 in. wide. Metal less than 5 ft long may be packed on pallets using crosswise skids.

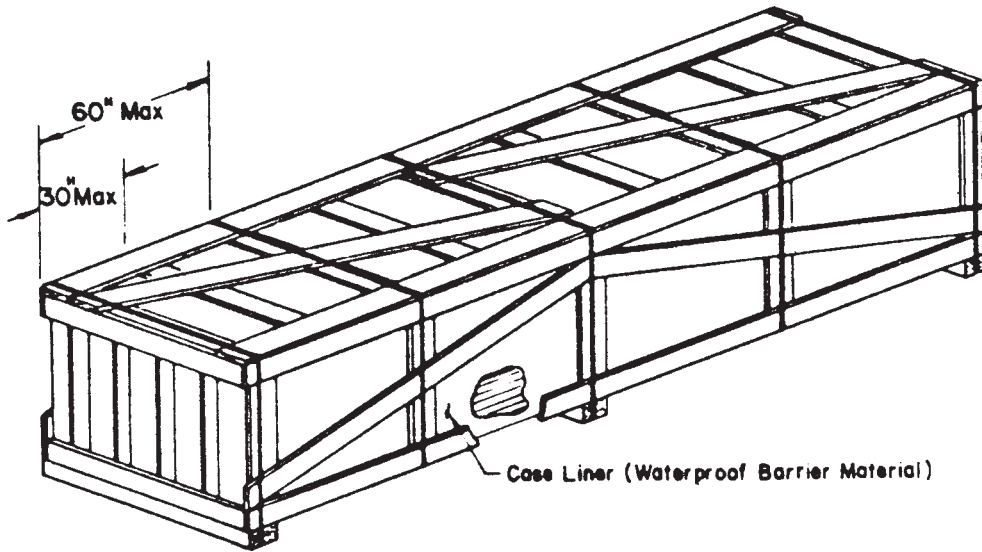
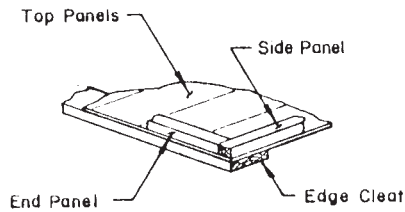
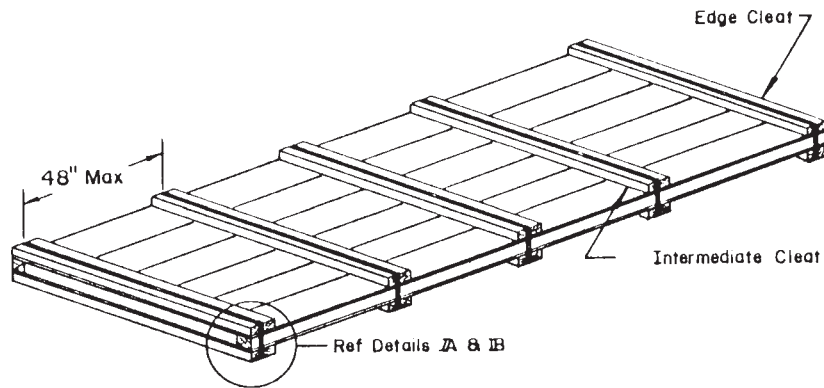
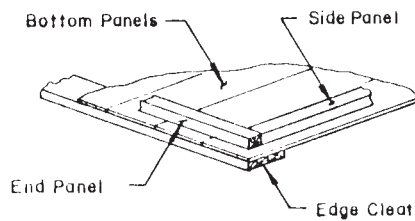

FIG. 23 Style 3 Crate, Open^G
^G For pipe.



DETAIL A
 TOP PANEL (INVERTED)



DETAIL B
 BOTTOM PANEL

FIG. 24 Wood Box for Flat Sheet (Telescopic)^K
^K For DoD redistribution.

7.3.4 *Double-Faced Pallets*, (Fig. 17 and Fig. 18)—Skids shall be 3 by 4-in. or 2 by 6-in. lumber or may be constructed

of laminated 1 by 6-in. or spliced 2 by 6-in. lumber. Joints in spliced 2 by 6-in. skids shall be reinforced with 2 by 6-in.

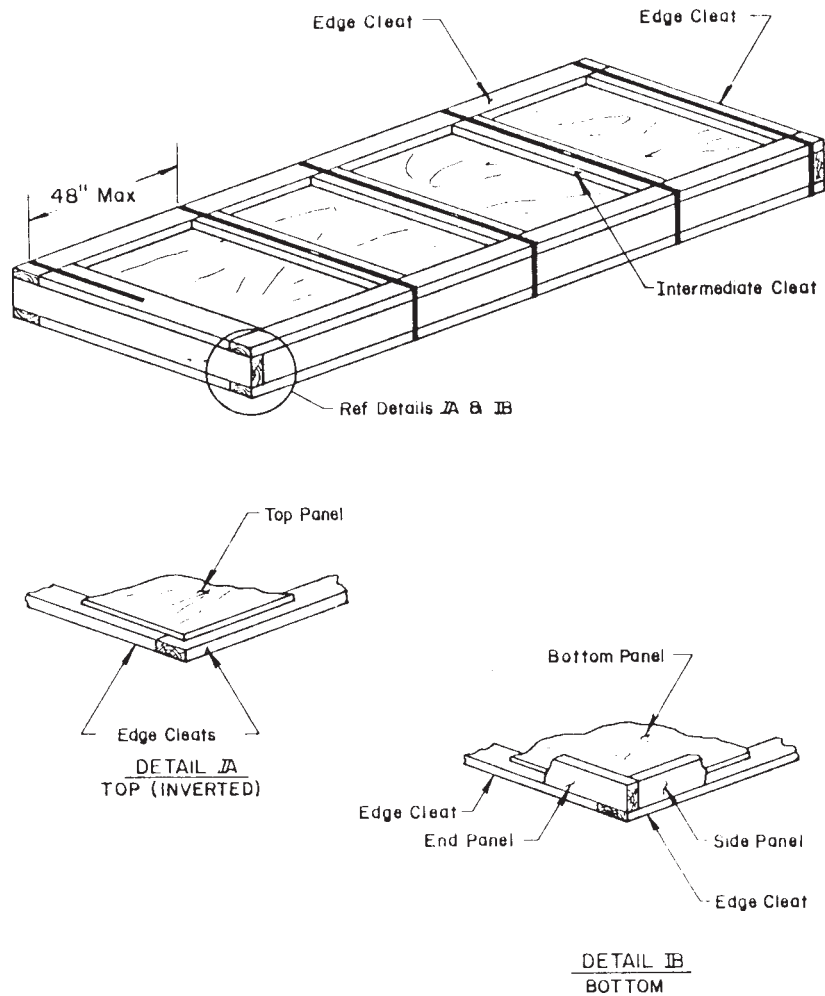

FIG. 25 Plywood or Paper Overlaid Veneer Box (Telescopic) for Flat Sheet^K

splice boards, long enough to contact the three stringers as shown in Fig. 18. Stringers shall be minimum 3 by 3 in. and may be fabricated from single piece lumber or laminated lumber of nominal 2 by 4 in. and larger. The end stringers shall be placed not more than 1 in. from the ends of the skids and deckboards. Additional stringers shall be spaced approximately 42 in. apart on center. Intervals between the last two stringers may vary but shall not exceed 48 in. For plate 1/2 in. thick and over, spacing of stringers may be increased but shall be such as to prevent sagging of metal between stringers. The stringers shall be placed so as not to interfere with center side forklift handling.

7.3.5 *Deckboards*—Deckboards shall be a minimum of 1 by 6-in. (nominal) lumber spaced a maximum of 8 in. apart. For plate 1/2 in. thick and over, spacing of deckboards shall be such as to prevent sagging of metal between deckboards.

7.3.6 *Nailing*—Nails shall be driven so that the head will not project above the surface of the deckboard. Occasional overdriving of nails will be permitted but no nail shall be overdriven more than 1/2 the thickness of the deckboard. Nails used in construction of pallets shall be Type II, Style 18 (screw-shanked) or equivalent ring-shanked of Specification F 1667 (pallet nails).

7.4 *Pallet Enclosure Construction* (see Fig. 19 and Fig. 20):

7.4.1 *Sides and Ends*—One-piece sides shall not be less than 1/2 in. thick and one-piece ends shall not be less than 3/4 in. thick. When sides and ends exceed 11 1/2 in. in height (Fig. 20), they shall be constructed like style 4 box (Fig. 4) and shall be not less than 3/4 in. thick.

7.4.1.1 *Side and End Battens (Cleats)*—When sides and ends are of Fig. 20 construction, minimum 1 by 4-in. battens and cleats shall be used. Side battens shall be placed under girthwise straps. End cleats shall be nailed.

7.4.2 *Tops*—Tops shall be of minimum 1/2-in. thick lumber, 1/2-in. thick plywood, 1/4-in. thick hardboard or equivalent materials.

7.4.2.1 *Top Battens*—Top battens shall be minimum 1 by 4-in. lumber. For lumber tops, battens shall be placed under each girthwise strap. For plywood and hardboard tops, battens shall be used only when the top consists of more than one piece of plywood or hardboard and shall be placed over each joint and underneath each girthwise strap.

7.4.3 *Nailing Sides, Ends and Tops*—When pallet enclosures are of Fig. 20 construction, sides, ends, and tops shall be nailed using good commercial practice. Sides, ends, tops, and bottoms shall not be nailed on pallet enclosures 11 1/2 in. or less in height, or for pallets of flat plate, roofing, and siding sheets unless specified in the contract or order.

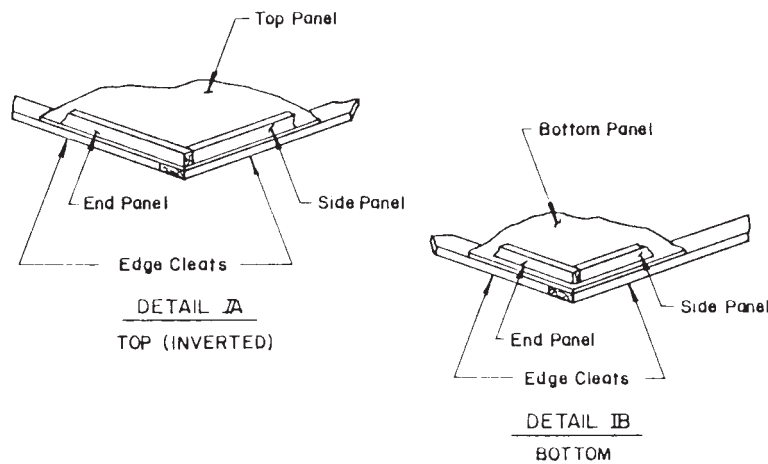
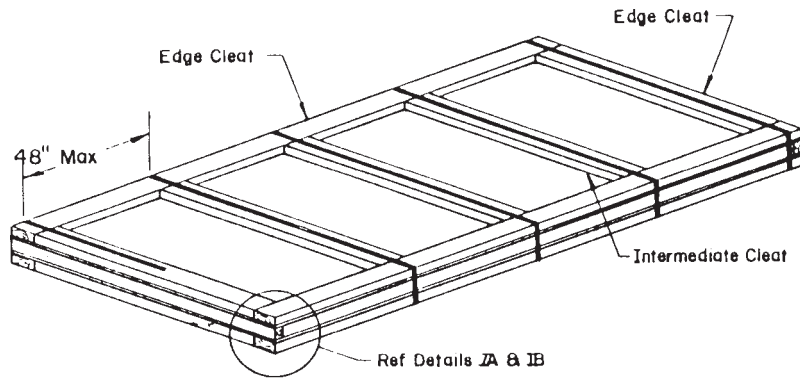

FIG. 26 Solid Fiberboard Panel Box (Telescopic) for Flat Sheet^K

7.4.4 *Strapping*—Flat steel strapping shall be minimum $\frac{3}{4}$ by 0.023 in. for pallets containing 4000 lb net weight or less and $1\frac{1}{4}$ by 0.031 in. for pallets containing over 4000 lb net weight.

7.4.4.1 *Strap Spacing*—A minimum of two lengthwise straps shall be used for widths less than 60 in. and three lengthwise straps for widths 60 in. and over. Lengthwise straps may be located under skids or under deckboards along side skids. Girthwise straps shall be placed not more than 9 in. from each end. Intermediate straps shall be applied at approximately 42-in. intervals and at plywood and hardboard joints. Girthwise straps shall pass between the deckboards and stringers or skids (Fig. 19 and Fig. 20).

7.5 *Pallet Enclosure Construction, 4000 lb Capacity for Aluminum Sheet* (see Fig. 21)—End panels shall be minimum 12 in. length. Side panels shall be minimum 24 in. length. End and side panels fit snug against the load of aluminum sheets to prevent shifting. End and side panels may be secured by toe nailing or angle brackets. Pallet construction shall be in accordance with 7.3 and Figs. 15-18, modified as shown in Fig. 21. Headers are not required. Pallet enclosure construction shall be in accordance with paragraphs under 7.4 except 7.4.3, nailing, does not apply. Sides, ends, and top shall be nailed so the enclosure can be removed and replaced as a cover. Pallet

enclosure shall fit over the end and side panels and shall not extend outside of pallet dimensions.

7.6 *Crates* (see Fig. 10, Fig. 22, and Fig. 23):

7.6.1 *Style 1 Crate* (Fig. 10)—Open crate for net weights not exceeding 700 lb and interior dimensions not exceeding 48 in. long by 42 in. wide by 48 in. high.

7.6.1.1 *Fabrication*—Style 1 crates shall be constructed of 1 by 4-in. lumber framing members, struts, and diagonals arranged as shown in Fig. 10. Spacing between struts shall be such as to prevent loss of contents. Diagonals may be placed on the inside or outside.

7.6.1.2 *Nailing*—Cement coated or chemically etched 7d nails shall be used. Bright nails may be used instead of coated or etched nails for Groups III and IV woods. Framing members and struts shall be fastened with a minimum of two nails at each end. Diagonals shall be fastened to other members with a minimum of three nails at each end.

7.6.1.3 *Strapping*—Flat steel strapping $\frac{5}{8}$ by 0.020 in. shall be used. Equivalent nonmetallic strapping may be used when comparable strength requirements are satisfied. Straps shall be applied perpendicular to the edges of the crate and tensioned to sink into the wood at the edges of the crate, provided corner protectors are not used.

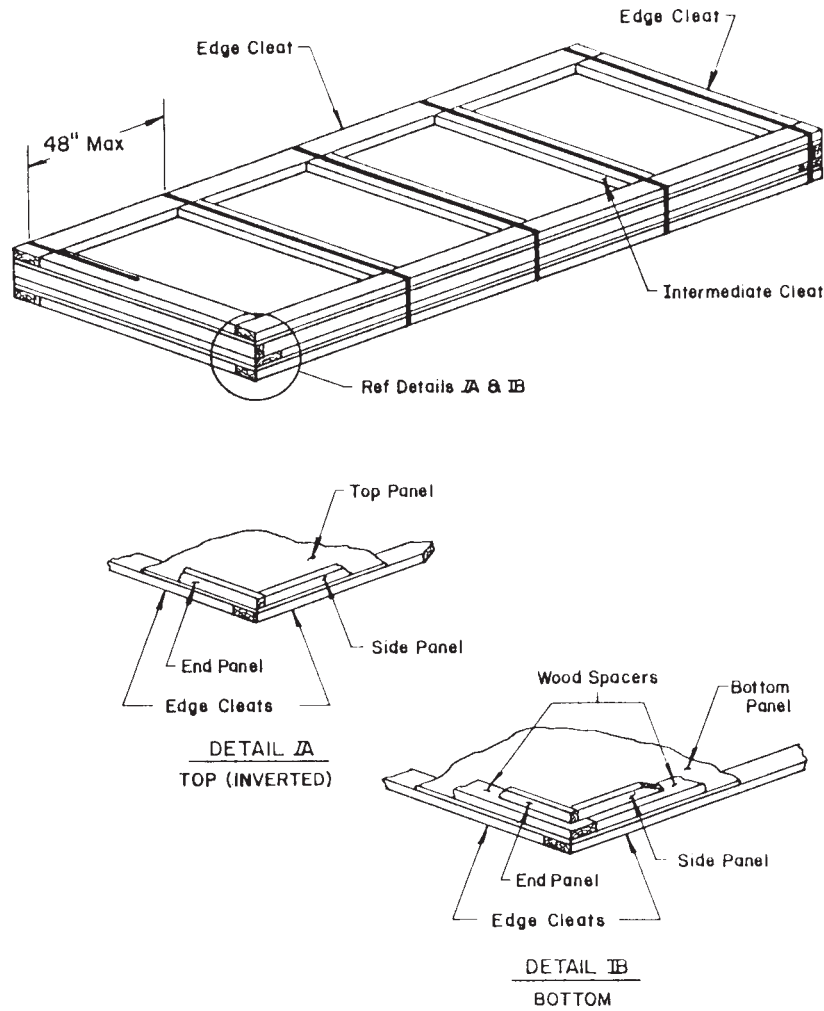

FIG. 27 Solid Fiberboard Panel Box, With Spacer (Telescopic) for Flat Sheet^K

TABLE 6 Species of Wood

Group I	Group II	Group III	Group IV
Alder, red	Douglas fir	Ash (except white ash)	Ash (white)
Aspen (popple)	Hemlock	Elm, soft	Beech
Basswood	Larch (tamarack)	Gum, red or black	Birch
Buckeye	Pine, Southern yellow	Maple, soft or California	Cherry
Butternut	Western larch	Oak, California	Elm, hard
Cedar		Sweetgum	Hackberry
Chestnut		Sycamore	Hickory
Cottonwood		Tupelo	Locust
Cypress			Maple, hard
Fir (<i>Abies sp</i>)			Oak
Magnolia			Pecan
Pine (except Southern yellow)			
Redwood			
Spruce			
Willow			
Yellow poplar			

7.6.1.3.1 Strap Spacing—Two girthwise straps shall be applied, one over each vertical framing member.

7.6.1.4 Skids—Skids fabricated from nominal 4 by 4-in. lumber or laminated 2 by 4-in. lumber shall be attached perpendicular to the long dimension of all crates with gross

weight exceeding 200 lb. As an alternative, Style 1 crates weighing over 200 lb gross may be strapped to a pallet.

7.6.2 Style 2 Crate (Fig. 22)—Open crate for net weights not exceeding 4000 lb and interior dimensions not exceeding 40 ft long by 6 ft wide by 4 ft high.

7.6.2.1 Fabrication—Style 2 crates shall be constructed with skids, deckboards, battens, framing members, ends, and sling reinforcements, arranged as shown in Fig. 22.

7.6.2.2 Skids (Runners)—A minimum of two skids shall be used for crates not exceeding 60 in. in width, and a minimum of three skids shall be used for crates exceeding 60 in. in width. Skids shall be fabricated from laminated 2 by 4-in. lumber or 4 by 4-in. lumber.

7.6.2.3 Deckboards—Deckboards function as bottom battens for the contents of the crate. Deckboards shall be 2 by 6-in. lumber, spaced not more than 12 in. from ends of crate and no more than 60 in. apart on centers and shall be secured to skids at each intersection. Deckboards shall extend approximately 1 in. beyond each side of contents.

7.6.2.4 Battens (Cleats)—Battens shall be of 2 by 6-in. lumber, grooved to retain straps placed around them. Battens shall be spaced identically with deckboards, side battens set on

TABLE 7 Wooden Boxes^A (Groups I and II Woods)^B (Figs. 2-8)

Weight of Contents lb	Length of Box in.	Style of Box	Figure Number	Sides, Top, and Bottom (Minimum Thickness) in.	Ends (min thick) in.	End Cleats (Minimum Thickness and Width), in.	Additional Cleats (Minimum Thickness and Width) in.
Less than 350	Less than 60	1	1	1/2	1 1/2
Less than 350	60 and over	1	5	5/8	1 1/2
Less than 350	Less than 60	2, 4, or 5	2, 3, and 4	1/2	3/4	3/4 by 2 1/2	...
Less than 350	60 and over	2 or 4	6 and 7	5/8	3/4	3/4 by 2 1/2	3/4 by 2 1/2
350 to 700	Less than 60	1	1	1/2	1 1/2
350 to 700	60 and over	1	5	5/8	1 1/2
350 to 700	Less than 60	2, 4, or 5	2, 3, and 4	5/8	3/4	3/4 by 2 1/2	...
350 to 700	60 and over	2 or 4	6 and 7	5/8	3/4	3/4 by 2 1/2	3/4 by 2 1/2
700 to 2000	Less than 60	1	1	5/8	1 1/2
700 to 2000	60 and over	1	5	11/16	1 1/2
700 to 2000	Less than 60	2, 4, or 5	2, 3, and 4	5/8	3/4	3/4 by 2 1/2	...
700 to 2000	60 and over	2 or 4	6 and 7	11/16	3/4	3/4 by 2 1/2	3/4 by 2 1/2

^A Includes circles less than 36 in. in diameter. For circles 36 in. in diameter and over see Table 10.

^B When Groups III and IV are used instead of Groups I and II, lumber may be 1/16 in. less in thickness than that specified for Groups I and II.

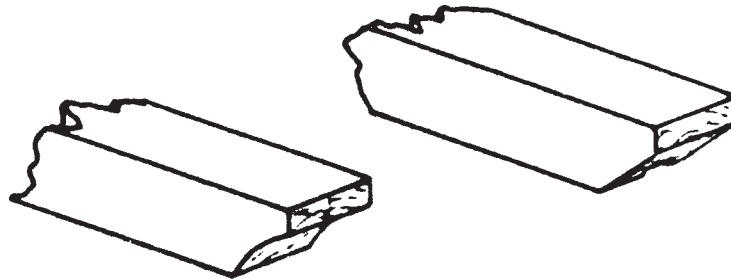

FIG. 28 Skid (Runner) Ends Dadoed or Beveled, Bottoms Notched (Mandatory for DoD otherwise optional)

1-in. extension of deckboards. Side battens shall be approximately 3/8 in. shorter than the height of the contents of the crate. Top battens shall extend approximately 1 in. beyond each side of contents of crates.

7.6.2.5 Framing Members—Framing members shall be 1 by 6-in. lumber and arranged as shown in Fig. 22.

7.6.2.6 Sling Reinforcements—Sling reinforcements shall be 2 by 6-in. lumber positioned on each side at each end between the lower longitudinal framing members and contents so as to distribute sling pressure over a greater area. Sling reinforcements shall extend the full distance between two sets of battens.

7.6.2.7 Ends—Ends shall be constructed of 1-in. lumber with 1 by 4-in. lumber framing or cleats around all edges of the end. Ends shall be the same dimensions as width and height of the contents of the crate plus the thickness of deckboards and battens.

7.6.2.8 Nails—Cement coated or chemically etched 7d nails shall be used. Bright nails may be used instead of coated or etched nails for Groups III and IV woods.

7.6.2.9 Strapping—Size of straps shall be as shown in Table 8. Straps shall be positioned girthwise over each set of deckboards and battens prior to application of framing members, ends, and sling reinforcements. Straps shall be tensioned to sink into the wood at the edges of the battens, provided corner protectors are not used, but shall not be tensioned to damage contents of crates.

7.6.2.10 Rubbing Strips—For DoD shipments, rubbing strips shall be added to crates 60 in. or more in length. Rubbing

TABLE 8 Strap Sizes for Styles 2 and 3 Crates (Fig. 22 and Fig. 23)

Weight of Contents, lb	Flat Steel Strapping, ^A in.
Less than 700	5/8 by 0.020
700 to 2000	3/4 by 0.023
2000 to 4000	3/4 by 0.031

^A Other equivalent strapping may be used when comparable strength requirements are met.

strips shall be fabricated from nominal 4 by 4 in. or laminated 2 by 4 in. lumber and shall be attached to skids in such manner as to provide four-way forklift entry. The bottom half of rubbing strip ends shall be beveled at a 45° angle.

7.6.3 Style 3 Crate (Fig. 23)—Open crate for net weights not exceeding 4000 lb and interior dimensions not exceeding 40 ft long by 6 ft wide by 4 ft high.

7.6.3.1 Fabrication—Style 3 crates shall be constructed with skids, cleats, framing members, and ends as shown in Fig. 23.

7.6.3.2 Skids (Runners)—Skids shall be 4 by 4-in. or laminated 2 by 4-in. lumber placed girthwise, located at each end of crate and spaced a maximum of 60 in. apart.

7.6.3.3 Framing Members and Cleats—Longitudinal framing members, diagonals, and cleats shall be 1 by 6-in. lumber and located as shown in Fig. 23. Top and bottom panels shall have girthwise cleats spaced a maximum of 30 in. apart. Side panels shall have vertical cleats spaced a maximum of 60 in. apart.

7.6.3.4 *Ends*—Ends shall be constructed of 1 by 6-in. lumber. Ends shall be the same dimensions as the width and height of the contents of the crate. Spacing between vertical end boards shall be such as to prevent loss of contents.

7.6.3.5 *Nails*—Cement coated or chemically etched 7d nails shall be used. Bright nails may be used instead of coated or etched nails for Groups III and IV woods.

7.6.3.6 *Strapping*—Size of straps shall be as shown in Table 8. Straps shall be positioned girthwise and centered over side panel framing members. Straps shall be tensioned so as to sink into the wood at the corners of the crate.

7.7 *Bundles, Pallets, and Coils* (Fig. 1, Fig. 11, Fig. 14, and Fig. 13)—Bundles, pallets, and coils shall be prepared as shown in Fig. 1, Fig. 11, Fig. 14, and Fig. 13. Pallet size (Fig. 14) shall not exceed 40 by 48 in.

7.7.1 *Strapping*—Coils shall be tied in a minimum of three places with flat strapping after wrapping (Fig. 1). Size of strapping for pallets (Fig. 14), bundles (Fig. 11 and Fig. 13) and coils (Fig. 1) shall be as shown in Table 3.

7.8 *Reels* (Fig. 9)—Reels shall be constructed as shown in Fig. 9. Reels shall be completely enclosed with wood lagging with lags touching each other. Lags shall be 1½-in. thick lumber and shall be nailed to the circumference of the head of the reel extending across the edges of both heads. Lags shall be tied with two ¾ by 0.025-in. flat steel straps or nonmetallic straps of comparable strength.

7.9 *Flanges for Supporting Coiled Foil* (Fig. 12)—Flanges shall be fabricated and positioned as shown in Fig. 12. Flanges supporting weights less than 100 lb shall be ⅝ in. thick. Flanges supporting weights of 100 lb and over shall be ¾ or ⅝ in. thick with ⅝ by 2½-in. vertical cleats.

NOTE 3—Several narrow coils may be suspended on one dowel.

7.10 *Spools*—Spools for products other than inert gas welding electrodes shall be standard commercial quality, type, and size normally used for aluminum and magnesium products. Spools for inert gas welding electrodes shall be in accordance with Table 9.

7.11 *Steel Pails*—Steel pails shall conform to or be equivalent with the requirements of Federal Specification PPP-P-704.

7.12 *Steel Drums*—Steel drums shall conform to or be equivalent with the requirements of Federal specification PPP-D-705 or PPP-D-729.

7.13 *Metal Cans*—Metal cans shall conform to the requirements of Federal Specification PPP-C-96, Type V, Class 2.

7.14 *Fiber Drums*—Fiber drums shall conform to or be equivalent with the requirements of Federal Specification PPP-D-723.

7.15 *Spirally Wound Fiber Tubes*—Spirally wound fiber tubes shall be fabricated in accordance with Federal Specification PPP-T-495, Type II, Class 1, Style A, with wood or metal ends. Crushing strength shall be 250 lbf/in. section instead of that specified with a minimum wall thickness of 0.250 in. The wood ends shall be cut the size of the inside diameter of the fiber tube from nominal 1-in. thick wood stapled to container walls. Staples shall be spaced a maximum of 1½ in. apart.

7.16 *Maximum Weight Per Container*—Maximum gross weights per container shall, unless otherwise agreed upon, be at the producer or supplier's discretion, provided that they are such to ensure acceptance by common or other carriers for safe transportation at the lowest rate to the delivery point. For DoD requirements, maximum net weight per container shall be the maximum acceptable weight specified in Table 1. *Exception:* When the weight of a single piece of metal exceeds this limitation, material will be packed one piece per pallet.

8. Commercial Packing

8.1 When commercial packing is specified, items may be packed in the manner employed by the supplier to afford protection against damage during shipment, and must, as a minimum, meet carrier rules and regulations. Weight per shipping unit, unless otherwise specified in the contract or order, shall be at the shipper's option. For additional examples of commercial packing, see Figs. 29-35.

9. Marking

9.1 Department of Defense (DoD) shipments, unless otherwise specified in the contract or order, shall be marked in accordance with MIL-STD-129 for Level A, and in accordance with the Supplementary Requirements of Practice D 3951.

10. Keywords

10.1 aluminum and magnesium products; packaging/packing

TABLE 9 Dimensions for Spools of Inert Gas Welding Electrodes (see Table 1)

Spool Part	1-lb Plastic Spool Size, ^A in.	10-lb Fiber Spool Size, ^A in.	12½-lb Plastic Spool Size, ^A in.
Width, overall	1¾ ± ⅓ ₂	4 ± ⅓ ₁₆	4 ± ⅓ ₁₆
Flange diameter	4 + 0, - ⅓ ₁₆	12 max ...	12 max ...
Arbor hole diameter	0.630 + 0.005 - 0.000	2⅓ ₁₆ + ⅓ ₁₆ - 0	2⅓ ₂ + ⅓ ₁₆ - 0
Engaging hole diameter	none...	⅓ ₁₆ + 0 - ⅓ ₂	⅓ ₁₆ + 0 - ⅓ ₂
Engaging hole location	none...	1¾ ± ⅓ ₆₄ (off center)	1¾ ± ⅓ ₆₄ (off center)

^A Tolerances allowed shall be as indicated.

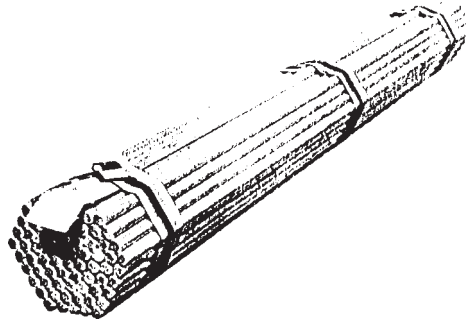

FIG. 29 Bare Bundle for Rod, Bar, Profiles, Tube

Bundle is unwrapped and will be steel strapped at both ends with protection beneath the straps. This entire bundle will be shipped on 2 by 4's or 4 by 4's to allow for overhead crane unloading.

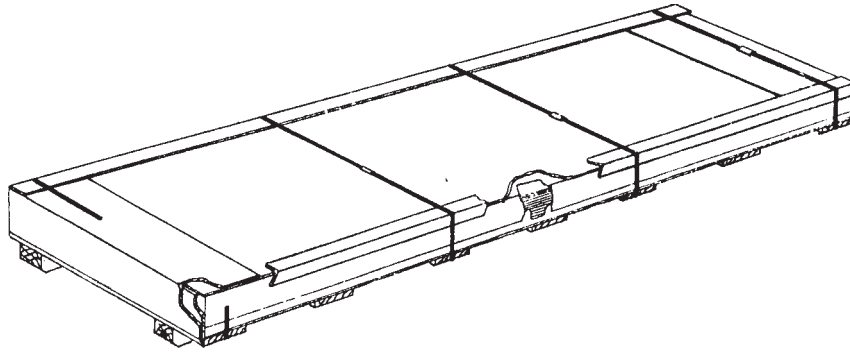

FIG. 30 Enclosed Pallet for Sheet

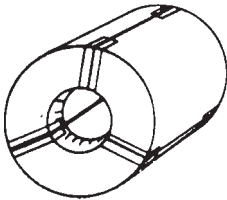

FIG. 31 Bulk Coil

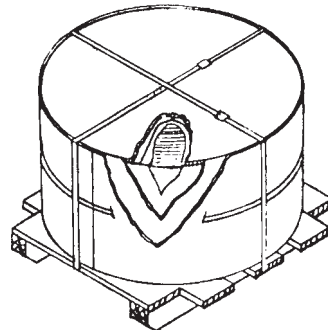

FIG. 33 Fiber Enclosed Skid for Coil

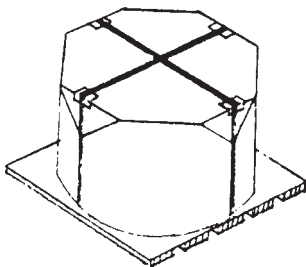

FIG. 32 Coil Skid

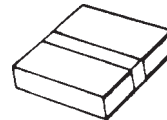

FIG. 34 Carton-Circles

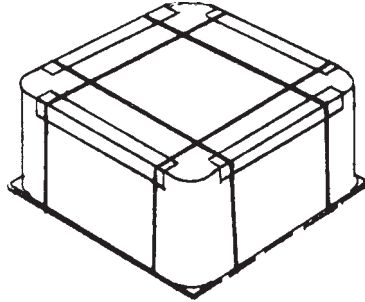

FIG. 35 Skid for Circles

SUPPLEMENTARY REQUIREMENTS

The following supplementary requirements apply to Department of Defense redistribution and shall apply when specified by the purchaser in the contract or order, and may be used by commercial suppliers.

S1. Construction of Boxes for Flat Sheet (Fig. 24, Fig. 25, Fig. 26, and Fig. 27)

S1.1 Material shall be boxed in wood (Fig. 24), plywood or paper overlaid veneer (Fig. 25) or solid fiberboard panel (Fig. 26 and Fig. 27) boxes. Quantity per box shall be limited to 500 lb gross weight. When shipment exceeds one box to a single destination, boxes shall be strapped to pallets (7.4) conforming to Fig. 15, Fig. 16, Fig. 17, or Fig. 18 as applicable with a minimum of three girthwise 1 1/4 by 0.031 in. steel straps. Not less than two lengthwise 1 1/4 by 0.031 in. steel straps shall be tension tied around the total load being palletized. Straps shall pass over existing top cleats or 1 by 2 in. battens shall be applied in the void and secured to the strapping with staples.

S1.2 Top and Bottom Panels—Top and bottom panels shall consist of a complete covering of lumber, plywood, paper overlaid veneer, or a single piece of solid sheet weather-resistant fiberboard.

S1.3 Side and End Panels—The thickness of the side and end panels for Figs. 24-27 boxes shall be such that the inside depth of the box corresponds with the thickness of the contents without voids.

S1.3.1 Fig. 24 Box—Side and end panels for Fig. 24 box shall consist of lumber attached to the top and bottom container panels to effect a telescopic closure. Lumber attached to the underside of the top panel shall be fastened flush with all outer edges. Lumber attached to the bottom panel shall be set in from the outer edges a distance sufficient to result in approximately 1/4 in. telescopic clearance to facilitate easy container closure. Depth thickness of side and end members shall be varied to obtain the desired depth of box not to exceed the maximum depth of Table 10. The total width of the side and end panels including maximum 1/4 in. telescoping tolerance, shall not be less than the width established in Table 10 when the container is closed. Side and end panels shall be nailed or stapled.

S1.3.2 Fig. 25 Box—Side and end panels for Fig. 25 box shall consist of lumber attached to the bottom container panel edge cleats as shown in detail A and B. The side and end panels shall be placed approximately 1/4 in. from the bottom panel to prevent binding when the top is placed on the container. Thickness of the side and end members shall be varied to

TABLE 10 Boxes for Flat Sheet (Figs. 24-27)

Style of Box (Fig. Number)	Depth of Box (Inside) in.	Sides and Ends (min thickness) in. ^A	Top and Bottom Thickness in.	Cleats (min thick and width) in.
25	2 1/2	1 1/2	1/2 ± 1/16	1/2 by 2 1/2
26	2 1/2	1	3/16 ± 1/16	1/2 by 2 1/2
27	^B	1 1/2	0.090	5/16 by 2 1/2
28	1 1/2 (includes thickness of spacer)	1 1/2	0.090	5/16 by 2 1/2

^A Thickness is that dimension measured from inside to outside of box. Includes telescoping tolerances.

^B Boxes not exceeding 8 ft in length, 1 1/2 in; boxes exceeding 8 ft in length, 3/4 in.

obtain the desired depth of box not to exceed the maximum depth of Table 10. The width of the side and end panels, including telescoping tolerance, shall be not less than the width established in Table 10 when the container is closed. Side and end panels shall be nailed or stapled.

S1.3.3 Fig. 26 Box—Side and end panels for Fig. 26 box shall be constructed as specified in S1.3.1 except that sides and ends shall be stapled.

S1.3.4 Fig. 27 Box—Side and end panels for Fig. 27 box shall consist of lumber attached to the top and bottom container panels to effect a telescopic closure. Side and end panels attached to the underside of the top panel shall be fabricated from maximum 3/4 by 3/4 in. lumber and shall be fastened flush with all outer edges. The bottom side and end panels shall be of 2 piece assembly, constructed by lamination 3/4 by 3/4 in. maximum dimension lumber to a lumber spacer not more than 3/4 by 1 1/2 in. in size as shown in detail A and B. The laminated assembly shall be attached to the bottom container panel flush with all outer edges. Side and end panels shall be stapled.

S1.4 Cleats:

S1.4.1 Top and bottom panels shall be provided with cleats in accordance with Table 10. Cleats, except for Fig. 26 and Fig. 27, shall be nailed or stapled. Fig. 26 and Fig. 27 edge cleats shall be stapled and glue laminated; intermediate cleats shall be glued only. Any water-resistant adhesive which provides a bond equivalent in strength to the material being bonded may be used.

S1.4.2 *Positioning of Cleats*—Lengthwise cleats shall extend the full length of the panel except Fig. 24 box will require no lengthwise cleats. Fig. 25 lengthwise and girthwise edge cleats shall be offset as shown in the detail a distance the width of the side and end panel plus ¼ in. Fig. 24 girthwise edge cleats and Fig. 25 and Fig. 26 lengthwise and girthwise edge cleats shall be flush with the outer edges of the top and bottom panels. Intermediate girthwise cleats, of the same width and thickness as the edge cleats, shall be placed a maximum of every 48 in. center-to-center. When top and bottom panels, Fig. 25 container, require girthwise splicing to facilitate covering of metal sheets more than 48 in. wide, the widths of the outer lengthwise edge cleats may exceed the requirements of Table 10 and incorporate the splicing requirements of 5.1.2.

S1.4.3 *Nailing and Stapling*—Size and spacing of nails and staples shall be in accordance with Table 11 and Table 12. Nails or staples used to attach Fig. 24 and Fig. 25 intermediate cleats shall be slightly overdriven in the sequence of through the panel and into the cleat and shall be clinched at least ⅛ in. Intermediate cleats for Fig. 26 and Fig. 27 boxes shall be fastened in accordance with S1.4.1. The sides and ends shall be stapled or nailed as required (see S1.4.1) to the top and bottom container panels with the same staples or nails used to attach cleats to the outer container edges of the top and bottom panels specified in S1.3 and S1.4.1. Staples and nails shall be driven in the sequence of through the cleats and into the sides and ends. No staple or nail shall be driven completely through the sides and ends. As an alternate for Fig. 24 and Fig. 25 boxes only, staples and nails may be driven in the sequence of through the sides and ends and into the cleats and shall be clinched at least ⅛ in. The positioning of the staples and nails

TABLE 11 Average Nail and Staple Spacing for Boxes for Flat Sheet (Fig. 21 and Figs. 24-27)

Parts Fastened	Spacing (Inches) ^A
Top and bottom to intermediate cleats on wood boxes (Fig. 21)	4
Top and bottom to intermediate cleats on plywood and POV boxes (Fig. 24)	12
Girthwise edge cleats and top and bottom to side and end panels on wood boxes (Fig. 21)	9
Edge cleats to top and bottom and side and end panels on plywood and POV boxes (Fig. 24)	9
Edge cleats to top and bottom and side and end panels on solid fiberboard panel boxes (Fig. 25 and Fig. 26)	9

^A Not less than one nail or staple shall be used at end of all cleats except Fig. 25 and Fig. 26 intermediate cleats.

TABLE 12 Nail and Staple Sizes for Boxes for Flat Sheet (Fig. 21 and Figs. 24-27)

Parts Nailed or Stapled	Nail or Staple Size ^{A,B,C}
Top and bottom to intermediate cleats (Fig. 24 and Fig. 21)	2 d
Edge cleats and top and bottom to side and end panels: (Fig. 24 and Fig. 21) (Fig. 25 and Fig. 26)	5 d to 12 d 0.0625 (16 gage)

^A 2 d nails or minimum 0.0625 in. diameter (16 gage) staples having minimum ⅞ in. crown with leg lengths equal to the sum of the thickness of the panels and cleats plus ⅛ in. and clinched.

^B Size of nail varies with the thickness of the top and bottom and side or end panel.

^C Length of staple shall be equal to thickness of cleat, panels and ½ to ⅞ of the height of the side and end.

shall not interfere with the container closure or come in contact with the packaged contents.

S2. Placing Material in Container

S2.1 When placing flat sheet in container, care shall be exercised to ensure that the surface containing item identification markings is placed upright for easy identification when top is removed.

S3. Closure (Strapping)

S3.1 Fig. 24, Fig. 25, Fig. 26, and Fig. 27 boxes shall be closed by strapping positioned at all girthwise cleats. Size of straps shall be in accordance with Table 3.

S4. Boxes for Products Other Than Flat Sheet

S4.1 When required by Table 1, products shall be packed in wood boxes (Figs. 2-8) and corrugated weather-resistant fiberboard boxes.

S5. Construction of Corrugated Weather-Resistant Fiberboard Boxes

S5.1 Triplewall corrugated weather-resistant fiberboard boxes shall be constructed in accordance with Practice D 5168. Singlewall and doublewall corrugated weather-resistant fiberboard boxes shall be constructed in accordance with Practice D 1974. Maximum inside dimensions of box (length, width, and depth added) shall not exceed 215 in. Weight limitations of Table 1 shall apply.

S6. Fig. 21, Fig. 24, and Fig. 25 Boxes

S6.1 Exterior container identification markings shall be in accordance with MIL-STD 129.

SUMMARY OF CHANGES

This section identifies the principal changes to this standard (I) The term “shape” was replaced by “profile.” that have been incorporated since the last issue.

ASTM International takes no position respecting the validity of any patent rights asserted in connection with any item mentioned in this standard. Users of this standard are expressly advised that determination of the validity of any such patent rights, and the risk of infringement of such rights, are entirely their own responsibility.

This standard is subject to revision at any time by the responsible technical committee and must be reviewed every five years and if not revised, either reapproved or withdrawn. Your comments are invited either for revision of this standard or for additional standards and should be addressed to ASTM International Headquarters. Your comments will receive careful consideration at a meeting of the responsible technical committee, which you may attend. If you feel that your comments have not received a fair hearing you should make your views known to the ASTM Committee on Standards, at the address shown below.

This standard is copyrighted by ASTM International, 100 Barr Harbor Drive, PO Box C700, West Conshohocken, PA 19428-2959, United States. Individual reprints (single or multiple copies) of this standard may be obtained by contacting ASTM at the above address or at 610-832-9585 (phone), 610-832-9555 (fax), or service@astm.org (e-mail); or through the ASTM website (www.astm.org).