



Designation: **B 788/B 788M – 9900**

## Standard Practice for Installing Factory-Made Corrugated Aluminum Culverts and Storm Sewer Pipe<sup>1</sup>

This standard is issued under the fixed designation B 788/B 788M; the number immediately following the designation indicates the year of original adoption or, in the case of revision, the year of last revision. A number in parentheses indicates the year of last reapproval. A superscript epsilon ( $\epsilon$ ) indicates an editorial change since the last revision or reapproval.

*This standard has been approved for use by agencies of the Department of Defense.*

### 1. Scope\*

1.1 This practice describes procedures, soils, and soil placement for the proper installation of corrugated aluminum culverts and storm sewers in either trench or projection installations. A typical trench installation is shown in Fig. 1, and a typical embankment (projection) installation is shown in Fig. 2. The pipes described in this practice are manufactured in a factory and furnished to the job in lengths ordinarily from 10 to 30 ft [3 to 9 m], with 20 ft [6 m] being common, for field joining.

1.2 This practice is applicable to either inch-pound units as B 788 or to SI units as B 788M. Inch-pound units are not necessary equivalent to SI units. SI units are shown in the text in brackets, and they are the applicable values for metric installation.

1.3 *This standard does not purport to address all of the safety concerns, if any, associated with its use. It is the responsibility of the user of this standard to establish appropriate safety and health practices and determine the applicability of regulatory limitations prior to use.*

### 2. Referenced Documents

2.1 *ASTM Standards:*

<sup>1</sup> This practice is under the jurisdiction of ASTM Committee ~~B-7~~ B07 on Light Metals and Alloys and is the direct responsibility of Subcommittee B07.08 on Aluminum Culvert.

Current edition approved May 10, ~~1999~~; 2000. Published August ~~1999~~; 2000. Originally published as B 788–88. Last previous edition B 788/B 788M–~~979~~.

**\*A Summary of Changes section appears at the end of this standard.**

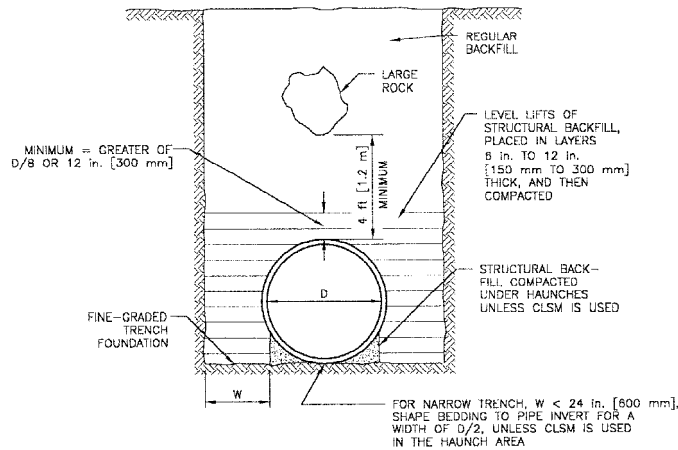

FIG. 1 Typical Trench Installation

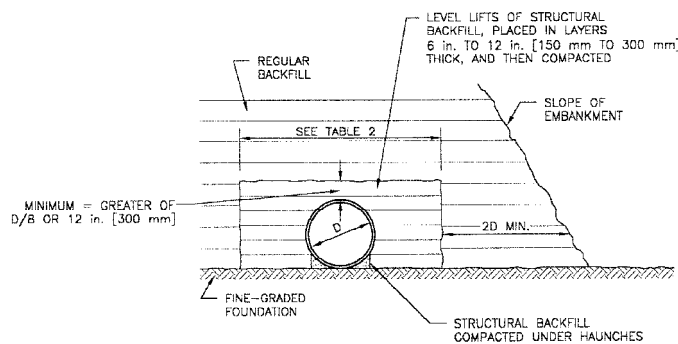

FIG. 2 Typical Embankment (Projection) Installation

B 790/B 790M Practice for Structural Design of Corrugated Aluminum Pipe, Pipe Arches, and Arches for Culverts, Storm Sewers, and Other Buried Conduits<sup>2</sup>

D 698 Test Method for Laboratory Compaction Characteristics of Soil Using Standard Effort (12,400 ft-lbf/ft<sup>3</sup> [600 kN-m/m<sup>3</sup>])<sup>1</sup>

D 1556 Test Method for Density and Unit Weight of Soil in Place by the Sand-Cone Method<sup>3</sup>

D 2167 Test Method for Density and Unit Weight of Soil in Place by the Rubber-Balloon Method<sup>3</sup>

D 2487 Classification of Soils for Engineering Purposes (Unified Soil Classification System)<sup>3</sup>

D 2922 Test Methods for Density of Soil and Soil-Aggregate in Place by Nuclear Methods (Shallow Depth)<sup>3</sup>

D 2937 Test Method for Density of Soil in Place by the Drive-Cylinder Method<sup>3</sup>

### 3. Terminology

3.1 *Definitions of Terms Specific to This Standard:*

3.1.1 *bedding, n*—the earth or other material on which a pipe is supported.

3.1.2 *haunch, n*—the portion of the pipe cross section between the maximum horizontal dimension and the top of the bedding.

3.1.3 *invert, n*—the lowest point on the pipe cross section; also, the bottom portion of a pipe.

3.1.4 *pipe, n*—a conduit having full circular shape; also, in a general context, all structure shapes covered by this practice.

3.1.5 *pipe-arch, n*—a pipe with an approximate semicircular crown, small-radius corners, and large-radius invert.

### 4. Significance and Use

4.1 Corrugated aluminum pipe functions structurally as a flexible ring which is supported by and interacts with the compacted surrounding soil. The soil constructed around the pipe is thus an integral part of the structural system. It is therefore important to ensure that the soil structure or backfill is made up of acceptable material and is well-constructed. Field verification of soil structure acceptability using Test Methods D 1556, D 2167, D 2922, or D 2937, as applicable, and comparing the results with Test Method D 698 in accordance with the specifications for each project, is the most reliable basis for installation of an acceptable structure. The required density and method of measurement are not specified by this practice, but they must be established in the specifications for each project.

<sup>2</sup> Annual Book of ASTM Standards, Vol 02.02.

<sup>3</sup> Annual Book of ASTM Standards, Vol 04.08.

## 5. Trench Excavation

5.1 To obtain anticipated structural performance of corrugated aluminum pipe it is not necessary to control trench width beyond the minimum required for proper installation of pipe and backfill. However, the soil on each side beyond the excavated trench must be able to support anticipated loads. When a construction situation calls for a relatively wide trench, it may be made as wide as required, for its full depth if so desired. However, trench excavation must be in compliance with any local, state, and federal codes and safety regulations.

## 6. Foundation

6.1 The supporting soil beneath the pipe must provide a reasonably uniform resistance to the imposed load, both longitudinally and laterally. Sharp variations in the foundation must be avoided. When rock is encountered, it must be excavated and replaced with soil. If the pipe runs along a continuous rock foundation, it is necessary to provide a suitable soil bedding under the pipe. See Fig. 3.

6.2 Lateral changes in foundation should never be such that the pipe is firmly supported while the backfill alongside is not. When soft material is encountered during construction and must be removed in order to provide an adequate foundation, remove the soft material for a distance of three pipe widths, unless the engineer has set another limit. See Fig. 4.

6.3 Performance of buried pipe is enhanced by allowing the pipe to settle slightly under load compared to the columns of soil alongside. Thus, for larger pipes it can be beneficial to purposely create a foundation under the pipe itself which will yield under load more than will the foundation under the columns of soil to each side. It can usually be obtained by placing a layer of compressible soil of a suitable thickness, less densely compacted than the soil alongside, beneath the structure. This creates favorable relative movement between pipe and the soil on each side. It is of particular importance on pipe-arches.

6.4 *Pipe-Arches*—All pipe-arch structures must have excellent soil support at their corners by both the in-situ foundation and the structural backfill. See Fig. 4 and Fig. 5. They do not require the same degree of support under their large-radius invert.

6.5 The engineer is encouraged to develop details specific to the site based on the general principles for foundation conditions given in 6.1 through 6.4.

## 7. Bedding

7.1 Corrugated aluminum pipe may be placed directly on the fine-graded foundation for the pipe line. Material in contact with the pipe shall not contain rock retained on a 3-in. [75-mm] ring, frozen lumps, chunks of highly plastic clay, organic matter, corrosive material, or other deleterious material. It is not required to shape the bedding to the pipe geometry. However, for pipe-arches, it is recommended to either shape the bedding to the relatively flat bottom arc or fine-grade the foundation to a slight v-shape. This avoids the problem of trying to backfill the difficult area beneath the invert of pipe-arches. See Fig. 5.

## 8. Pipe Installation

8.1 All pipe shall be unloaded and handled with reasonable care. Pipe shall not be rolled or dragged over gravel or rock and shall be prevented from striking rock or other hard objects during placement on bedding. Pipe with protective coatings shall be

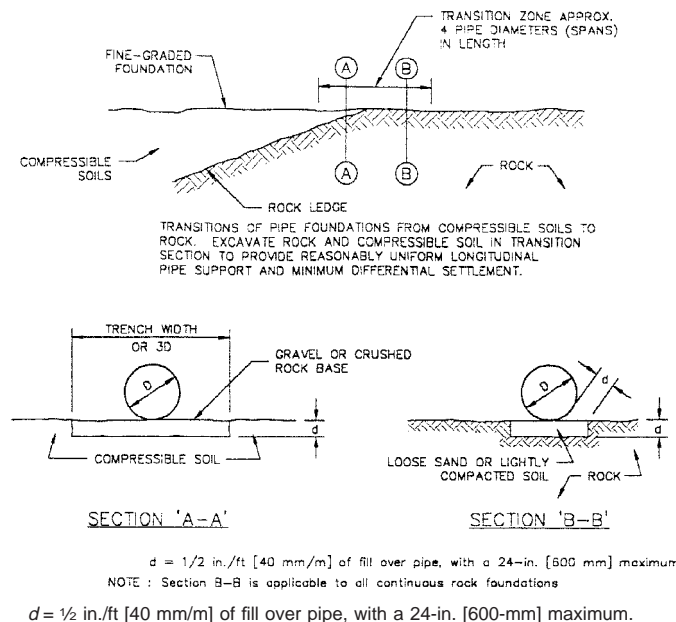

NOTE 1—Section B-B is applicable to all continuous rock foundations.

**FIG. 3 Foundation Transition Zones and Rock Foundations**

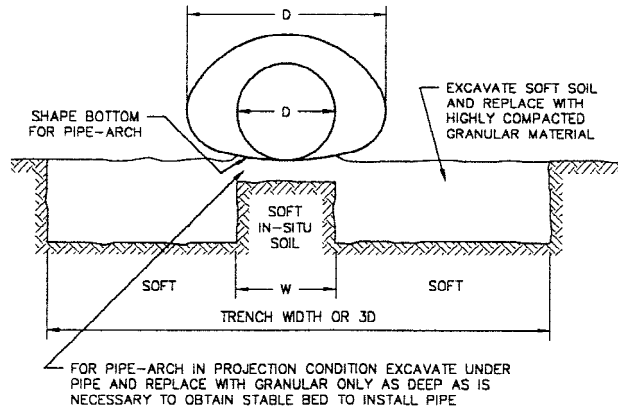

W = D for round pipe  
W = width of flat bottom arc for pipe-arch

FIG. 4 Soft Foundation Treatment

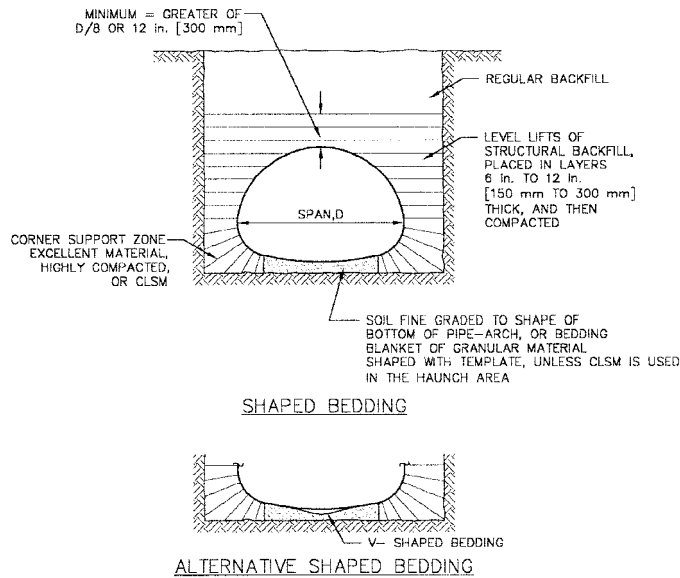

FIG. 5 Bedding and Corner Zone Treatment for Pipe-Arch Structures

handled with special care to avoid damage. Paved inverts shall be placed and centered in the invert.

### 8.2 Field Joints:

8.2.1 Transverse field joints shall be of such design that the successive connection of pipe sections will form a continuous line free of appreciable irregularities in the flow line. Each successive length of pipe in a field joint should be adjusted longitudinally or circumferentially when necessary so that coupling bands with projections, helical corrugations, or annular corrugations will properly engage the corrugations in both lengths of pipe. In addition, the joints shall meet the general performance requirements described herein. Suitable transverse field joints, which satisfy the requirements for one or more of the subsequently defined joint performance categories, can be obtained with the following types of connecting bands furnished with the suitable band-end fastening devices:

8.2.1.1 Corrugated bands.

8.2.1.2 Bands with projections.

8.2.1.3 Flat bands.

8.2.1.4 Bands of special design that engage factory reformed ends of corrugated pipe.

8.2.1.5 Other equally effective types of field joints may be used with the approval of the engineer.

8.2.2 *Joint Types*—Applications may require either standard or special joints. Standard joints are for pipe not subject to large soil movements or disjoining forces. These joints are satisfactory for ordinary installations, where simple slip-type joints are typically used. Special joints are for more adverse requirements such as the need to withstand soil movements or resist disjoining forces. Stab joints are for pipes subject to minimal settlement or disjoining forces. Special designs must be considered for unusual conditions such as in poor foundation conditions.

NOTE 1—Examples of stab joints are bell and spigot, and tongue and groove.

### 8.2.3 Soil Conditions:

8.2.3.1 The requirements of the joints are dependent upon the soil conditions at the construction site. Pipe backfill that is not subject to piping action is classified as nonerrodible. Such backfill typically includes granular soil (with grain sizes equivalent to coarse sand, small gravel, or larger) and cohesive clays.

8.2.3.2 Structural backfill that is subject to piping action, and would tend either to infiltrate the pipe or to be easily washed by exfiltration of water from the pipe, is classified as errodible. Such backfill typically includes fine sands and silts.

8.2.4 *Joint Properties*—The requirements for joint properties are divided into six categories. The properties are defined in 8.2.4.1-8.2.4.6, and requirements (except for watertightness) are shown in Table 1. The values for various types of pipe can be determined by a rational analysis or a suitable test.

8.2.4.1 *Shear Strength*—The shear strength required of the joint is expressed as a percent of the calculated shear strength of the pipe on a transverse cross section remote from the joint.

8.2.4.2 *Moment Strength*—The moment strength required of the joint is expressed as a percent of the calculated moment capacity of the pipe on a transverse cross section remote from the joint.

8.2.4.3 *Tensile Strength*—Tensile strength is required in a joint when the possibility exists that a longitudinal load could develop that would tend to separate adjacent pipe sections.

8.2.4.4 *Joint Overlap*—Standard joints that do not meet the moment strength alternatively shall have a minimum sleeve width overlapping the abutting pipes. The minimum total sleeve width shall be as shown in Table 1. Any joint meeting the requirements for a special joint may be used instead of a standard joint.

8.2.4.5 *Soiltightness*—Soiltightness refers to openings in the joint through which soil may infiltrate. Soiltightness is influenced by the size of the opening (maximum dimension normal to the direction that the soil may infiltrate) and the length of the channel (length of the path along which the soil may infiltrate). No opening may exceed 1 in. [25 mm]. In addition, for all categories, if the size of the opening exceeds 1/8 in. [3 mm], the length of the channel must be at least four times the size of the opening. Furthermore, for nonerrodible or errodible soils, the ratio of  $D_{85}$  soil size to size of opening must be greater than 0.3 for medium to fine sand or 0.2 for uniform sand; these ratios need not be met for cohesive backfills where the plasticity index exceeds 12. ( $D_{85}$  is the soil diameter at which 85 % of the soil weight is finer.) As a general guideline, a backfill material containing a high percentage of fine grained soils requires investigation for the specific type of joint to be used to guard against soil infiltration. Alternatively, if a joint demonstrates its ability to pass a 2 psi [14 kPa] hydrostatic test without leakage, it will be considered soiltight.

8.2.4.6 *Watertightness*—Watertightness may be specified for joints of any category where needed to satisfy other criteria. The leakage rate shall be measured with the pipe in place or at an approved test facility.

## 9. Structural Backfill Material

9.1 Structural backfill is that material that surrounds the pipe, extending laterally to the walls of the trench, or to the fill material for embankment construction, and extending vertically from the invert to an elevation of 1 ft [300 mm] or 1/8 the diameter or span, whichever is greater, over the pipe. The necessary width of structural backfill depends on the quality of the trench wall or embankment material, the type of material and compaction equipment used for the structural backfill, and in embankment construction, the type of construction equipment used to compact the embankment fill. The width of structural backfill shall meet the requirements given in Table 2.

9.2 Structural backfill material shall be fine, readily compacted soil or granular fill material. Structural backfill material may be excavated native material, when suitable, or select material. Select materials such as bank-run gravels or other processed granular

**TABLE 1 Categories of Pipe Joints**

Joint Properties	Soil Condition					
	Nonerrodible Joint Type			Erodible Joint Type		
	Stab <sup>A</sup>	Standard	Special	Stab <sup>A</sup>	Standard	Special
Shear strength, %	2	2	5	2	2	5
Shear strength, % <sup>B</sup>	2	2	5	2	2	5
Moment strength, % <sup>B</sup>	0	5	15	0	5	15
Moment strength, % <sup>B</sup>	0	5	15	0	5	15
Tensile strength, min, lbf (kN):						
Tensile strength, min, lbf [kN]:						
0 to 42-in. [0 to 1050-mm] diameter	0	0	5 000 [22]	0	0	5 000 [22]
0 to 42-in. [0 to 1050-mm] diameter	0	0	5000 [22]	0	0	5000 [22]
48 to 84-in. [1200 to 2100-mm] diameter		10 000 [44]		10 000 [44]		
48 to 84-in. [1200 to 2100-mm] diameter			10 000 [45]			10 000 [45]
Joint overlap, min, in. [mm] <sup>C</sup>	3 [75]	10 1/2	NA	3 [75]	10 1/2 [265]	NA
Joint overlap, min, in. [mm] <sup>C</sup>	3 [75]	10 1/2 [265]	NA	3 [75]	10 1/2 [265]	NA
Soiltightness <sup>D</sup>	NA	NA	NA	0.3 or 0.2	0.3 or 0.2	0.3 or 0.2

<sup>A</sup> Stab joint for maximum 42 in. [1050 mm] diameter.

<sup>B</sup> See 8.2.4.2.

<sup>C</sup> Alternative requirement. See 8.2.4.4.

<sup>D</sup> Minimum ratio of  $D_{85}$  soil size to size of opening 0.3 for medium to fine sand and 0.2 for uniform sand.

**TABLE 2 Structural Backfill Width Requirements<sup>A,B</sup>**

Adjacent Material	Required Structural Backfill Width
Normal highway embankment compacted to minimum of 90 % Test Method D 698 density, or equivalent trench wall.	As needed to establish pipe bedding and to fill and compact the backfill in the haunch area and beside the pipe. Where backfill materials that do not require compaction are used, such as cement slurry or controlled low strength material (CLSM), a minimum of 3 in. [75 mm] on each side of the pipe is required.
Embankment or trench wall of lesser quality.	Increase backfill width as necessary to reduce horizontal pressure from pipe to a level compatible with bearing capacity of adjacent materials.

<sup>A</sup> For pipe arches and other multiple radius structures, as well as for all structures carrying off-road construction equipment, the structural backfill width, including any necessary foundation improvement materials, must be sufficient to reduce the horizontal pressure from the structure so that it does not exceed the bearing capacity of the adjacent material.

<sup>B</sup> In embankment construction, the structural backfill width must be adequate to resist forces caused by the embankment construction equipment. Generally, the width on each side of the pipe should be no less than 1 diameter, or span, or 2 ft [600 mm], whichever is less.

materials less than 3 in. [75 mm] maximum with excellent structural characteristics are preferred. Desired end results can be obtained with this type of material with a minimum of compaction effort over a wide range of moisture content, lift depth, and compaction equipment characteristics. Excavated native soils used as structural backfill shall not contain stones retained on a 3-in. [75 mm] ring, frozen lumps, highly plastic clay, organic material, corrosive material, or other deleterious foreign materials. Soil classifications are defined in Classification D 2487. Soils meeting the requirements of groups GW, GP, GM, GC, SW, and SP are generally acceptable, when compacted to the specified percent of maximum density as determined by Test Method D 698. Test Methods D 1556, D 2167, D 2922, and D 2937 may be used to determine the in-place density of the soil. Soil types SM and SC are acceptable, but they may require closer control to obtain the specified density. Soil Groups ML and CL are not preferred materials, while soil Groups OL, MH, CH, OH, and PT are not acceptable.

9.3 Special materials other than soil may be used as described in 10.1.

## 10. Structural Backfill Placement

10.1 Structural backfill shall be placed in layers from 6 to 12 in. [150 to 300 mm] in depth depending on the type of material and compaction equipment or method. Each layer or lift shall be compacted before adding the next lift. On flat bedding, care must be taken to place material under the pipe haunches and compact it firmly. Structural backfill on each side of the pipe shall be kept in balance. Generally, no more than one lift difference should be permitted. Construction equipment shall not be used over or alongside the pipe without sufficient compacted soil between it and the pipe to prevent distortion, damage, or overstressing. Mechanical soil compaction of layers is preferred. However, when acceptable end results can be achieved with water consolidation, it may be used. When water methods are used, care must be taken to prevent flotation. Water methods shall be used only on free-draining structural backfill material. If cohesive soils are used as structural backfill, good compaction can only be obtained at proper moisture content. Shallower lifts are generally required for acceptable end results with cohesive soils than with granular or mixed soils. In general, much closer inspection and testing must be exercised to ensure good results with cohesive structural backfill material. Water compaction is not acceptable with cohesive material. Unusual field conditions may make relatively costly special backfill material practical. Materials that set up without compaction, such as cement slurry, controlled low strength material (CLSM), and various foamed mixtures, provide excellent structural backfill provided they are designed to yield the compressive strength required. As with water compaction, care must be taken to avoid flotation.

10.2 The compaction of structural backfill shall provide a soil structure around the pipe to uniformly apply overburden pressures on the crown of the pipe and provide uniform bearing for the pipe side walls and lower haunches. The required degree of compaction will vary with the job and structural backfill material. The structural backfill is an integral part of the design process. Therefore, required end results regarding in-place density of structural backfill shall be in accordance with job specifications. Most structural design tables for corrugated aluminum pipe establish maximum overfill depths based on a specified field density of 90 % in accordance with Test Method D 698 with good structural backfill material. However, the majority of sewer pipe installations do not require deep overfills. For relatively shallow buried pipes not subject to live load, an acceptable structural backfill material and its degree of compaction may be determined by the character of the adjacent ground. A balanced design making the conduit homogeneous with the ground on either side is often desirable. For this reason, it is not practical to establish arbitrary minimums for soil characteristics of structural backfill for all installations.

10.3 *Pipe-Arches*—Special attention must be given to the material used and compaction obtained around the corners of pipe-arches. Vertical load over the pipe is transmitted into the soil principally at the corners. Therefore, the quality of structural backfill is particularly important adjacent to pipe-arch corners. In the case of higher fills or deep trenches, special designs may be required for corner backfill zones.



10.4 Generally, construction experience and a site appraisal will establish the most economical combination of material, method, and equipment to yield acceptable end results. Test Method D 698 is the preferred means of determining maximum (standard) density and optimum moisture content. A construction procedure must then be established that will result in the specified percent of maximum density. Once that is established, the primary inspection effort should be directed at ensuring that the established procedure is followed. Such a procedure may involve material, depth of lift, moisture content, and compactive effort. Only occasional checks may then be required, as long as the material and procedures are unchanged. In situ density may be determined by Test Methods D 1556, D 2167, D 2922, and D 2937, as applicable, for field verification. Testing should be conducted on both sides of the structure. Construction methods and equipment that achieve required end results without damage to or distortion of the pipe shall be acceptable.

10.5 *Shape Control*—Excessive compaction, unbalanced loadings, loads from construction equipment, as well as inadequate compaction or poor backfill materials, can cause excessive pipe distortion. For larger pipe, the construction contractor may set up a shape monitoring system, prior to placement of structural backfill, to aid in establishing and maintaining proper installation procedures. Direct measurement of span and rise, offset measurements from plumb bobs hanging over reference points, and similar types of measurements are effective means for monitoring shape change during backfill placement and compaction. In general, it is desirable for the crown of the pipe to rise slightly, in a balanced concentric manner, during placement and compaction of soil beside the pipe. Under the load of the completed fill and the service load, vertical deflections will be a small percentage of the pipe rise dimension if backfill compaction is adequate.

## 11. Regular Backfill

11.1 Regular backfill in trench installation is that material replaced in the trench above the structural backfill. In projection conditions, it is also the embankment fill adjacent to the structural backfill.

11.2 Regular backfill shall consist of native materials and shall be placed and compacted as required by job specifications. Large rocks or boulders shall not be placed within 4 ft [1.2 m] of the pipe. Large boulders should not be permitted in regular backfill in trenches that are under surface structures, including pavements. Construction equipment shall not be used over or alongside the pipe without sufficient compacted soil between it and the pipe to prevent distortion, damage, or overstraining.

## 12. Multiple Structures

12.1 When two or more structures are installed in adjacent lines, the minimum spacing requirements given in Practice B 790/B 790M must be provided.

## 13. Keywords

13.1 aluminum pipe; corrugated aluminum pipe; culvert; installation—underground; sewers

## SUMMARY OF CHANGES

Committee ~~B-7~~ B07 has identified the location of selected changes to this standard since the last issue (B 788/B 788M-979) that may impact the use of this standard.

~~(1) In general, changes were made to bring this practice into line with its coated steel counterpart Practice A 798/A 798M on Installing Factory-Made Corrugated Steel Pipe Included joints for Sewers and Other Applications: pipes larger than 84 in. in diameter.~~

~~(2) Changes were made to the figures to make their wording consistent with that in the text of the practice.~~

~~(3) General revisions were made to grammar and terminology.~~

~~(4) The location of references to the figures have been corrected.~~

~~(5) Parentheses around SI units have been replaced with brackets.~~

~~(6) References to this document being a specification have been replaced with “practice.”~~

~~(7) Table 1 now includes a Included stab-type coupler.~~

~~(8) Paragraph 8.2.3.3 has been removed, since this information is presented joints for pipes through 42 in. in paragraph 8.2.2: diameter.~~

*ASTM International takes no position respecting the validity of any patent rights asserted in connection with any item mentioned in this standard. Users of this standard are expressly advised that determination of the validity of any such patent rights, and the risk of infringement of such rights, are entirely their own responsibility.*

*This standard is subject to revision at any time by the responsible technical committee and must be reviewed every five years and if not revised, either reapproved or withdrawn. Your comments are invited either for revision of this standard or for additional standards and should be addressed to ASTM International Headquarters. Your comments will receive careful consideration at a meeting of the responsible technical committee, which you may attend. If you feel that your comments have not received a fair hearing you should make your views known to the ASTM Committee on Standards, at the address shown below.*

*This standard is copyrighted by ASTM International, 100 Barr Harbor Drive, PO Box C700, West Conshohocken, PA 19428-2959, United States. Individual reprints (single or multiple copies) of this standard may be obtained by contacting ASTM at the above address or at 610-832-9585 (phone), 610-832-9555 (fax), or [service@astm.org](mailto:service@astm.org) (e-mail); or through the ASTM website ([www.astm.org](http://www.astm.org)).*