



Designation: **B 790/B 790M – 9900**

## **Standard Practice for Structural Design of Corrugated Aluminum Pipe, Pipe- Arches, and Arches for Culverts, Storm Sewers, and Other Buried Conduits<sup>1</sup>**

This standard is issued under the fixed designation B 790/B 790M; the number immediately following the designation indicates the year of original adoption or, in the case of revision, the year of last revision. A number in parentheses indicates the year of last reapproval. A superscript epsilon ( $\epsilon$ ) indicates an editorial change since the last revision or reapproval.

### **1. Scope\***

1.1 This practice is intended for the structural design of corrugated aluminum pipe and pipe-arches, and aluminum structural plate pipe, pipe-arches, and arches for use as culverts and storm sewers and other buried conduits. This practice is for pipe installed in a trench or embankment and subjected to highway, railroad, and aircraft loadings. It must be recognized that a buried corrugated aluminum pipe is a composite structure made up of the aluminum ring and the soil envelope, and both elements play a vital part in the structural design of this type of structure.

1.2 Corrugated aluminum pipe and pipe-arches shall be of annular fabrication using riveted seams, or of helical fabrication having a continuous lockseam.

1.3 Structural plate pipe, pipe-arches, and arches are fabricated in separate plates that when assembled at the job site by bolting form the required shape.

1.4 This specification is applicable to design in inch-pound units as Specification B 790 or in SI units as Specification B 790M. Inch-pound units and SI units are not necessarily equivalent. SI units are shown in brackets in the text for clarity, but they are the applicable values when the design is done in accordance with Specification B 790M.

1.5 *This standard does not purport to address all of the safety concerns, if any, associated with its use. It is the responsibility of the user of this standard to establish appropriate safety and health practices and determine the applicability of regulatory limitations prior to use.*

### **2. Referenced Documents**

2.1 *ASTM Standards:*

<sup>1</sup> This practice is under the jurisdiction of ASTM Committee ~~B-7~~ B07 on Light Metals and Alloys and is the direct responsibility of Subcommittee B07.08 on Aluminum Culvert.

Current edition approved ~~May~~ July 10, ~~1999~~, 2000. Published ~~August~~ ~~1999~~, September 2000. Originally published as B 790–90. Last previous edition B 790–979.

**\*A Summary of Changes section appears at the end of this standard.**

- B 745/B 745M Specification for Corrugated Aluminum Pipe for Sewers and Drains<sup>2</sup>  
 B 746/B 746M Specification for Corrugated Aluminum Alloy Structural Plate for Field-Bolted Pipe, Pipe-Arches, and Arches<sup>2</sup>  
 B 788/B 788M Practice for Installing Factory-Made Corrugated Aluminum Culverts and Storm Sewer Pipe<sup>2</sup>  
 B 789/B 789M Practice for Installing Corrugated Aluminum Structural Plate Pipe for Culverts and Sewers<sup>2</sup>  
 D 698 Test Method for Laboratory Compaction Characteristics of Soil Using Standard Effort (12 400 ft-lbf/ft [600 kN-m/m<sup>3</sup>])<sup>3</sup>  
 D 1556 Test Method for Density and Unit Weight of Soil In Place by the Sand-Cone Method<sup>3</sup>  
 D 2167 Test Method for Density and Unit Weight of Soil In Place by the Rubber Balloon Method<sup>3</sup>  
 D 2487 Classification of Soils for Engineering Purposes (Unified Soil Classification Systems)<sup>3</sup>  
 D 2922 Test Methods for Density of Soil and Soil-Aggregate In Place by Nuclear Methods (Shallow Depth)<sup>3</sup>  
 D 2937 Test Methods for Density of Soil In Place by the Drive-Cylinder Method<sup>3</sup>  
 2.2 *FAA Standards*:<sup>4</sup>  
 AC No. 150/5320-5B, Advisory Circular, “Airport Drainage,” Department of Transportation, Federal Aviation Administration, Publication No. SN-050-007-00149-5, 1970  
 2.3 *AASHTO Standards*:<sup>5</sup>  
 Specifications for Highway Bridges

### 3. Terminology

- 3.1 *Definitions of Terms Specific to This Standard*:
- 3.1.1 *arch, n*—a pipe shape that is supported on footings and does not have a full metal invert.  
 3.1.2 *bedding, n*—the earth or other material on which the pipe is laid consist of a thin layer of important material on top of the in-situ foundation.  
 3.1.3 *haunch, n*—the portion of the pipe cross section between the maximum horizontal dimension and the top of the bedding.  
 3.1.4 *invert, n*—the lowest portion of the pipe cross section; also, the bottom portion of the pipe.  
 3.1.5 *pipe, n*—a conduit having a full circular shape or, in a general contex, all structure shapes covered by this practice.  
 3.1.6 *pipe-arch, n*—a pipe shape consisting of an approximate semicircular top portion, small radius corners, and large radius invert.

### 4. Symbols

4.1 The symbols used in this practice have the following significance:

fc FF fy H max H min P f r rc R f s S

- A* = required wall area, in.<sup>2</sup>/ft [mm<sup>2</sup>/mm],  
*AL* = maximum highway design axle load, lbf [N],  
*d* = depth of corrugation, in. [mm],  
*E* = modulus of elasticity, 10 × 10<sup>6</sup> lbf/in.<sup>2</sup> [69 × 10<sup>3</sup> MPa],  
*EL* = earth load, lbf/ft<sup>2</sup> [kPa],  
~~*FF* *fc* = flexibility factor, in./lbf [mm/N], critical buckling stress, lbf/in.<sup>2</sup> [MPa],~~  
~~*fy* *FF* = specified minimum yield strength, lbf/in.<sup>2</sup>~~  
~~= 24 000 lbf/in.<sup>2</sup> [165.5 MPa] for structural plate meeting B 746/B 746M,~~  
~~= 20 000 lbf/in.<sup>2</sup> [140MPa] for pipe meeting B 745/B 745M, flexibility factor, in./lbf [mm/N],~~  
*fu* = specified minimum tensile strength lbf/in.<sup>2</sup> strength,  
 = 31 000 lbf/in.<sup>2</sup> [213.7[215 MPa] for structural plate meeting corrugated aluminum pipe per B 7465/B 7465M using Alclad Alloy 3004–H34,  
 = 27 000 lbf/in.<sup>2</sup> [185 MPa] for corrugated aluminum pipe meeting per B 745/B 745M using Alclad Alloy 3004–H32,  
 = 35 000 lbf/in.<sup>2</sup> [245 MPa] for 0.100 through 0.150 inch [2.52 through 3.81 mm] thick aluminum structural plate per B 746/B 746M,  
 = 34 000 lbf/in.<sup>2</sup> [235 MPa] for 0.175 through 0.250 inch [4.44 through 6.35 mm] thick aluminum structural plate per B 746/B 746M,  
~~*fey* = critical buckling stress, specified minimum yield strength,~~  
~~= 20 000 lbf/in.<sup>2</sup> [140 MPa] for corrugated aluminum pipe per B 745/B 745M using Alclad Alloy 3004–H32,~~  
~~= 24 000 lbf/in.<sup>2</sup> [165 MPa] for all other corrugated aluminum pipe and structural plate per B 745/B 745M and B 746/B 746M,~~  
*H* = depth of fill above top of pipe, ft [m],

<sup>2</sup> Annual Book of ASTM Standards, Vol 02.02.

<sup>3</sup> Annual Book of ASTM Standards, Vol 04.08.

<sup>4</sup> Available from Standardization Documents Order Desk, Bldg. 4 Section D, 700 Robbins Ave., Philadelphia, PA 19111-5094, Attn: NPODS.

<sup>5</sup> Available from American Association of State Highway and Transportation Officials, 444 N. Capitol Street NW, Suite 225, Washington, DC 20001.

- $H_{\min}$  = minimum maximum depth of fill, ft [m],
- $H_{\max}^{\max}$  = maximum minimum depth of fill, ft [m],
- $I^{\min}$  = moment of inertia of ~~corrugated shape~~, corrugation, in.<sup>4</sup>/in. [mm<sup>4</sup>/mm], see Tables 1-7),
- IL = impact load, lbf/ft<sup>2</sup> [kPa],
- k = soil stiffness factor—0.22 for good sidefill material compacted to 90 % of standard density based on Test Methods D 698,
- LL = live load, lbf/ft<sup>2</sup> [kPa],
- P = total design load or pressure, lbf/ft<sup>2</sup> [kPa],
- $P_f$  = Factored crown pressure, lbf/ft<sup>2</sup> [kPa],
- r = radius of gyration of corrugation, in. [mm], see Tables 1-7,
- $r_c$  = corner radius of pipe-arch, ft [mm],
- $S R_f$  = pipe diameter or span, ft [m], Factored resistance for each limit state, lbf/ft [kN/m],
- s = pipe diameter or span, in. [mm],
- $P_L$  = Factored crown pressure, lbf/ft<sup>2</sup> [kPa],
- $R_n$  = Nominal resistance for each limit state, lbf/ft [kN/m],
- $R_{r,s}$  = Factored resistance for each limit state, lbf/ft [kN/m], pipe diameter or span, in. [mm],
- $T_{r,s}$  = Factored thrust in pipe wall, lbf/ft [kN/m], diameter or span, ft [m],
- $\phi$  = Resistance factor,
- SF = safety factor,
- SS = required seam strength, lbf/ft [kN/m],
- T = thrust in pipe wall, lbf/ft [kN/m], and
- $T_f$  = Factored thrust in pipe wall, lbf/ft [kN/m],
- $\bar{W}$  = the unit force derived from 1 ft<sup>3</sup> [m<sup>3</sup>] of fill material above the pipe, lbf/ft<sup>3</sup> [kN/m<sup>3</sup>]. When the actual fill material is not known, use 120 lbf/ft<sup>3</sup> [19 kN/m<sup>3</sup>],
- $\phi$  = Resistance factor.

NOTE 1—For pipes meeting B 745/B 745M, both minimum yield and minimum tensile strengths are based on the H-32 temper material.

### 5. Basis of Design

5.1 The recommendations presented herein, represent generally accepted design practice. The design engineer shall, however, determine that these recommendations meet particular project needs.

### 6. Loads

6.1 The design load or pressure on a pipe is comprised of earth load (EL), live load (LL), and impact load (IL). These loads are applied as a fluid pressure acting on the pipe periphery.

6.2 For aluminum pipe buried in a trench or in an embankment on a yielding foundation, loads are defined as follows:

**TABLE 1 Sectional Properties of Corrugated Aluminum Sheets  
for Corrugation: 1½ by ¼ in. [38 by 6.5 mm] (Helical)**

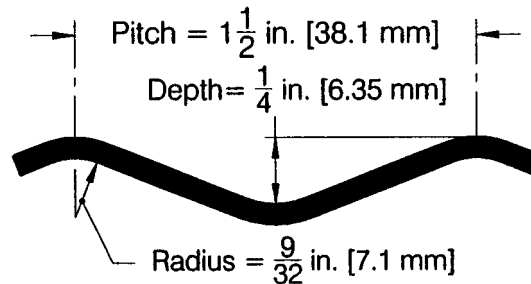

NOTE 1—Dimensions shown in the figure are exact values used in calculating the section properties. Nominal values for some of these dimensions are used in other places in this practice.

Specified Thickness, in. [mm]	Area of Section A, in. <sup>2</sup> /ft [mm <sup>2</sup> /mm]	Moment of Inertia, I × 10 <sup>-3</sup> in. <sup>4</sup> /in. [mm <sup>4</sup> /mm]	Radius of Gyration, r, in. [mm]
0.048 [1.22]	0.608 [1.287]	0.344 [5.64]	0.0824 [2.093]
0.060 [1.52]	0.761 [1.611]	0.439 [7.19]	0.0832 [2.113]

TABLE 2 Sectional Properties of Corrugated Aluminum Sheets for Corrugation: 2 by 1/2 in. [51 by 13 mm] (Helical)

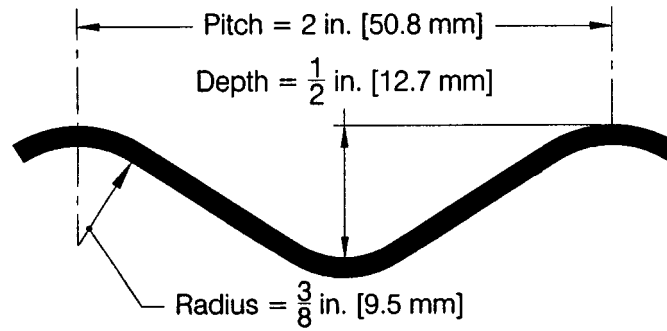

NOTE 1—Dimensions shown in the figure are exact values used in calculating the section properties. Nominal values for some of these dimensions are used in other places in this practice.

Specified Thickness, in. [mm]	Area of Section A, in. <sup>2</sup> /ft [mm <sup>2</sup> /mm]	Moment of Inertia, I × 10 <sup>-3</sup> in. <sup>4</sup> /in. [mm <sup>4</sup> /mm]	Radius of Gyration, r, in. [mm]
0.048 [1.22]	0.652 [1.380]	1.533 [25.12]	0.1682 [4.272]
0.060 [1.52]	0.815 [1.725]	1.942 [31.82]	0.1690 [4.293]
0.075 [1.91]	1.019 [2.157]	2.458 [40.28]	0.1700 [4.318]
0.105 [2.67]	1.428 [3.023]	3.542 [58.04]	0.1725 [4.382]

TABLE 3 Sectional Properties of Corrugated Aluminum Sheets for Corrugation: 2 2/3 by 1/2 in. [68 by 13 mm] (Helical or Annular)

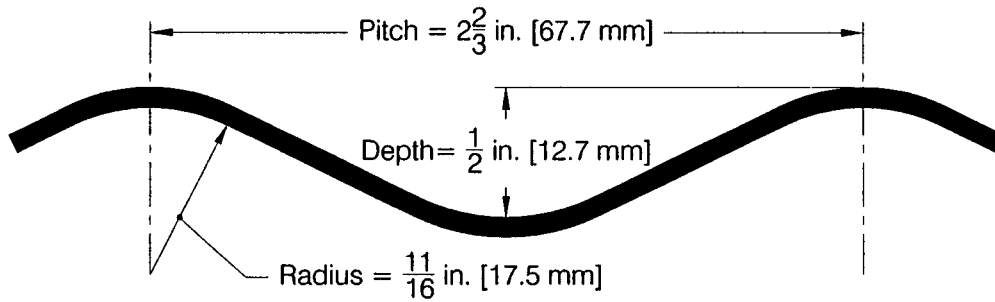

NOTE 1—Dimensions shown in the figure are exact values used in calculating the section properties. Nominal values for some of these dimensions are used in other places in this practice.

Specified Thickness, in. [mm]	Area of Section A, in. <sup>2</sup> /ft [mm <sup>2</sup> /mm]	Moment of Inertia, I × 10 <sup>-3</sup> in. <sup>4</sup> /in. [mm <sup>4</sup> /mm]	Radius of Gyration, r, in. [mm]	Ultimate Longitudinal Seam Strength of Riveted Corrugated Aluminum Pipe, Pounds [kN] per Foot [metre] of Seam			
				5/16-in. [7.94 mm] Rivets		3/8-in. [9.53 mm] Rivets	
				Single <sup>A</sup>	Double <sup>B</sup>	Single <sup>A</sup>	Double <sup>B</sup>
0.060 [1.52]	0.775 [1.640]	1.892 [31.00]	0.1712 [4.348]	9000 [131]	14 000 [204]	...	...
0.075 [1.91]	0.968 [2.049]	2.392 [39.20]	0.1721 [4.371]	9000 [131]	18 000 [263]	...	...
0.105 [2.67]	1.356 [2.870]	3.425 [56.13]	0.1741 [4.422]	...	...	15 600 [228]	31 500 [460]
0.135 [3.43]	1.745 [3.694]	4.533 [74.28]	0.1766 [4.486]	...	...	16 200 [237]	33 000 [482]
0.164 [4.17]	2.130 [4.509]	5.725 [93.82]	0.1795 [4.559]	...	...	16 800 [245]	34 000 [496]

<sup>A</sup> Single means one row of rivets, one rivet per corrugation.

<sup>B</sup> Double means two rows of rivets, one rivet per corrugation per row.

6.2.1 *Earth Load*—The earth load *EL* is the weight of the column of soil directly above the pipe calculated as:

$$EL = HW \tag{1}$$

6.2.2 *Live Loads*—The live load *LL* is that portion of the weight of the vehicle, train, or aircraft moving over the pipe that is distributed through the soil to the pipe.

6.2.2.1 *Live Loads Under Highways*—Live load pressures for H20 highway loadings, including impact effects, are as follows:

**TABLE 4 Sectional Properties of Corrugated Aluminum Sheets for Corrugation: 3 by 1 in. [75 by 25 mm] (Helical or Annular)**

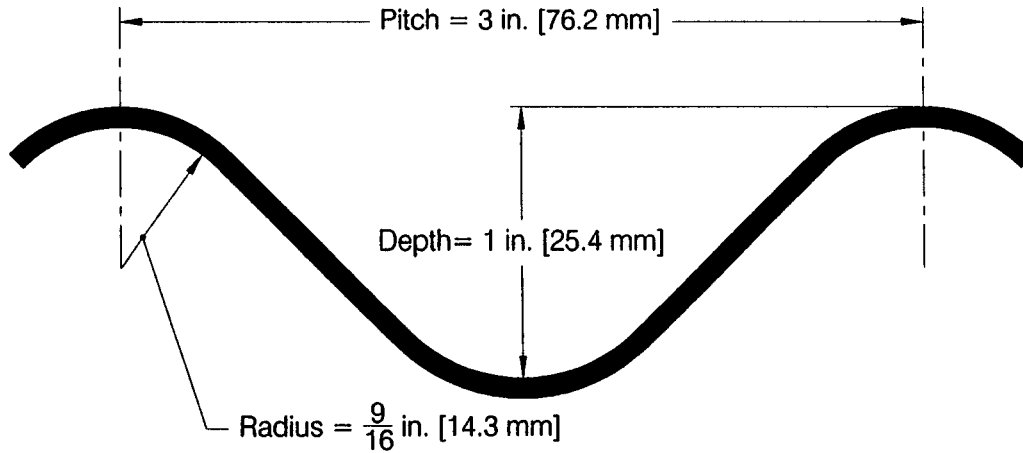

NOTE 1—Dimensions shown in the figure are exact values used in calculating the section properties. Nominal values for some of these dimensions are used for other places in this practice.

Specified Thickness, in. [mm]	Area of Section A, in. <sup>2</sup> /ft [mm <sup>2</sup> /mm]	Moment of Inertia, $I \times 10^{-3}$ , in. <sup>4</sup> /in. [mm <sup>4</sup> /mm]	Radius of Gyration, $r$ , in. [mm]	Ultimate Longitudinal Seam Strength of Riveted Corrugated Aluminum Pipe, Pounds [kN] per Foot [metre] of Seam	
				$\frac{3}{8}$ -in. [9.53 mm] Rivets	$\frac{1}{2}$ -in. [12.70 mm] Rivets
				Double <sup>A</sup>	Double <sup>A</sup>
0.060 [1.52]	0.890 [1.884]	8.659 [141.90]	0.3417 [8.679]	16 500 [241]	...
0.075 [1.91]	1.118 [2.366]	10.883 [178.34]	0.3427 [8.705]	20 500 [299]	...
0.105 [2.67]	1.560 [3.302]	15.459 [253.33]	0.3448 [8.758]	...	28 000 [409]
0.135 [3.43]	2.008 [4.250]	20.183 [331.74]	0.3472 [8.819]	...	42 000 [613]
0.164 [4.17]	2.458 [5.203]	25.091 [411.17]	0.3499 [8.887]	...	54 500 [795]

<sup>A</sup> Double means two rows of rivets, one rivet per corrugation per row.

Height of Cover, ft [mm]	Live Load, lbf/ft <sup>2</sup> [kPa]
1 [300]	1800 [86.2]
2 [600]	800 [38.3]
3 [900]	600 [28.7]
4 [1200]	400 [19.2]
5 [1500]	250 [12.0]
6 [1800]	200 [9.6]
7 [2100]	175 [8.4]
8 [2400]	100 [4.8]
over 8 [over 2400]	neglect [neglect]

6.2.2.2 *Live Loads Under Railways*—Live load pressures for E80 railway loadings, including impact effects, are as follows:

Height of Cover, ft [mm]	Live Load, lbf/ft <sup>2</sup> [kPa]
2 [600]	3800 [181.9]
5 [1500]	2400 [114.9]
8 [2400]	1600 [76.6]
10 [3000]	1100 [52.7]
12 [3600]	800 [38.3]
15 [4500]	600 [28.7]
20 [6000]	300 [14.4]
30 [9000]	100 [4.8]
over 30 [over 9000]	neglect [neglect]

Values for intermediate covers may be interpolated.

6.2.2.3 *Live Loads Under Aircraft Runways*— Because of the many different wheel configurations and weights, live load pressures for aircraft vary. Such pressures must be determined for the specific aircraft for which the installation is designed; see the FAA publication “Airport Drainage.”

6.2.3 *Impact Loads*—Loads caused by the impact of moving traffic are important only at low heights of cover. Their effects have been included in live load pressures in 6.2.2.

## 7. Design Method

7.1 Strength requirements for wall strength, buckling strength, and seam strength may be determined by either the allowable

**TABLE 5 Sectional Properties of Corrugated Aluminum Plates for Corrugation: 9 by 2½ in. [230 by 64 mm]**

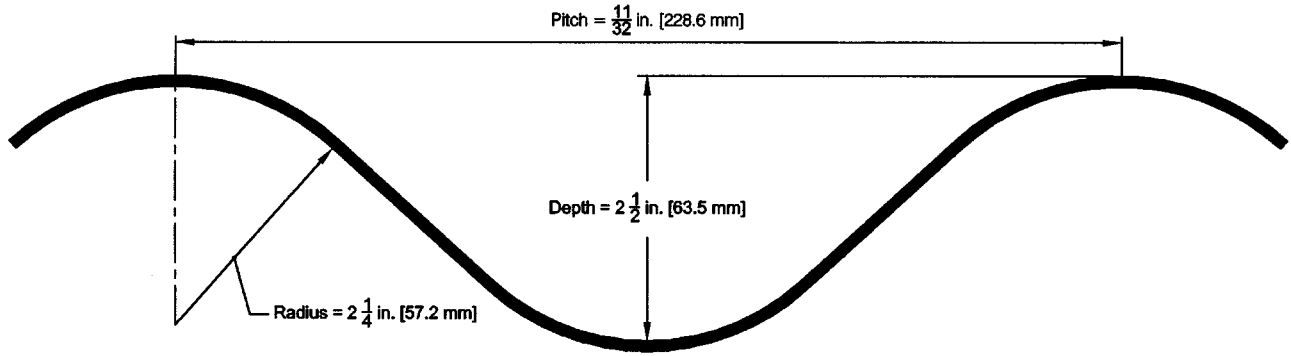

NOTE 1—Dimensions shown in the figure are exact values used in calculating the section properties. Nominal values for some of these dimensions are used in other places in this practice.

Specified Thickness, in. [mm]	Area of Section A, in. <sup>2</sup> /ft [mm <sup>2</sup> /mm]	Moment of Inertia, I × 10 <sup>-3</sup> in. <sup>4</sup> /in. [mm <sup>4</sup> /mm]	Radius of Gyration, r, in. [mm]	Ultimate Strength of Bolted Structural Plate Longitudinal Seams, Pounds [kN] per Foot [metre] of Seam (¾-in. [19 mm] Bolts)	
				Steel Bolts, 4 Bolts Per Corrugation	Aluminum Bolts, 4 Bolts Per Corrugation
0.100 [2.54]	1.404 [2.972]	83.065 [1361.19]	0.844 [21.438]	28 000 [409]	26 400 [385]
0.125 [3.18]	1.750 [3.704]	103.901 [1702.63]	0.844 [21.438]	41 000 [598]	34 800 [508]
0.150 [3.81]	2.100 [4.445]	124.883 [2046.47]	0.845 [21.463]	51 100 [746]	44 400 [648]
0.175 [4.44]	2.449 [5.184]	145.845 [2389.97]	0.845 [21.463]	63 700 [930]	52 800 [771]
0.200 [5.08]	2.799 [5.925]	166.959 [2735.97]	0.846 [21.488]	73 400 [1071]	52 800 [771]
0.225 [5.72]	3.149 [6.665]	188.179 [3083.70]	0.847 [21.514]	83 200 [1214]	52 800 [771]
0.250 [6.35]	3.501 [7.410]	209.434 [3432.01]	0.847 [21.514]	93 100 [1359]	52 800 [771]

**TABLE 6 Sectional Properties of Aluminum Spiral Rib Pipe for Rib ¾ in. [19 mm] Wide by ¾ in. [19 mm] Deep With a Spacing of 7½ in. [190 mm] Center to Center (Helical)**

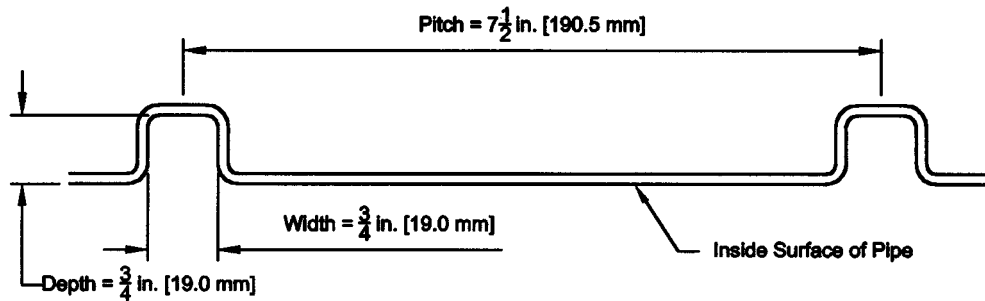

NOTE 1—Net effective properties at full yield stress.

NOTE 2—Net effective properties at full yield stress.

Specified Thickness, in. [mm]	Effective Properties			Radius of Gyration, r, in. [mm]
	Area of Section A, in. <sup>2</sup> /ft. [mm <sup>2</sup> /mm]	Moment of Inertia, I × 10 <sup>-3</sup> in. <sup>4</sup> /in. [mm <sup>4</sup> /mm]	Radius of Gyration, r, in. [mm]	
0.060 [1.52]	0.415 [0.878]	2.558 [41.92]	0.272 [6.91]	
0.075 [1.91]	0.569 [1.204]	3.372 [55.26]	0.267 [6.78]	
0.105 [2.67]	0.914 [1.935]	5.073 [83.13]	0.258 [6.55]	
0.135 [3.43]	1.290 [2.730]	6.826 [111.86]	0.252 [6.40]	

stress design (ASD) method presented in Section 8, or the load and resistance factor design (LRFD) method presented in Section 9. Additionally, the design considerations in other paragraphs shall be followed for either design method.

### 8. Design by ASD Method

8.1 The thrust in the pipe wall shall be checked by three criteria. Each considers the joint function of the aluminum pipe and the surrounding soil envelope.

**TABLE 7 Sectional Properties of Aluminum Spiral Rib Pipe for Rib 3/4 in. [19 mm] Wide by 1 in. [25 mm] Deep With a Spacing of 11 1/2 in. [292 mm] Center to Center (Helical)**

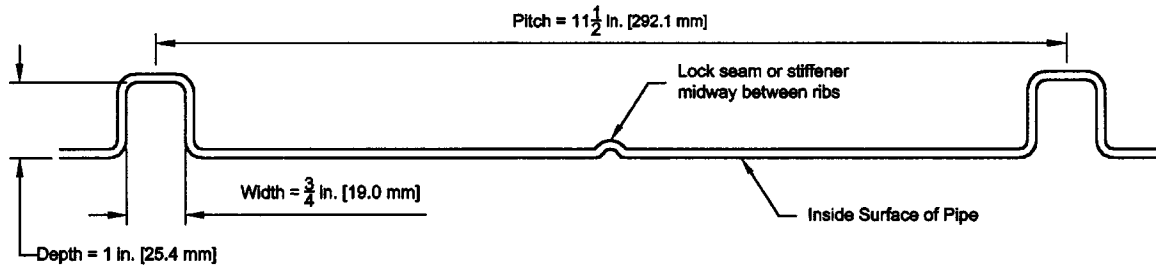

NOTE 1—Dimensions shown in the figure are exact values used in calculating the section properties. Nominal values for some of these dimensions are used in other places in this practice.

NOTE 2—Net effective properties at full yield stress.

Effective Properties			
Specified Thickness, in. [mm]	Area of Section A, in. <sup>2</sup> /ft. [mm <sup>2</sup> /mm]	Moment of Inertia, I × 10 <sup>-3</sup> in. <sup>4</sup> /in. [mm <sup>4</sup> /mm]	Radius of Gyration, r, in. [mm]
0.060 [1.52]	0.312 [0.660]	4.080 [66.86]	0.396 [10.058]
0.075 [1.91]	0.427 [0.904]	5.450 [84.31]	0.391 [9.931]
0.105 [2.67]	0.697 [1.475]	8.390 [137.49]	0.380 [9.652]
0.135 [3.43]	1.009 [2.136]	11.480 [188.12]	0.369 [9.874]

### 8.1.1 Required Wall Area:

8.1.1.1 Determine the design pressure and ring compression thrust in the aluminum pipe wall as follows:

$$P = EL + LL + IL \quad (2)$$

$$T = PS/2 \quad (3)$$

8.1.1.2 Determine the required wall cross-sectional area. The safety factor *SF* on the wall area is 2.

$$A = \frac{T(SF)}{f_y} \quad (4)$$

Select from Tables 1-7 a wall thickness equal to or greater than the required wall area *A*.

8.1.2 **Critical Buckling Stress**—Check corrugations with the required wall area for possible wall buckling. If the critical buckling stress *f<sub>c</sub>* is less than the minimum yield stress *f<sub>y</sub>*, recalculate the required wall area using *f<sub>c</sub>* instead of *f<sub>y</sub>*.

$$\text{If } s < \frac{r}{k} \sqrt{\frac{24E}{f_u}} \text{ then } f_c = f_u - \frac{f_u^2}{48E} \left(\frac{ks}{r}\right)^2 \quad (5)$$

$$\text{If } s > \frac{r}{k} \sqrt{\frac{24E}{f_u}} \text{ then } f_c = \frac{12E}{\left(\frac{ks}{r}\right)^2} \quad (6)$$

### 8.1.3 Required Seam Strength:

8.1.3.1 Since a helical lockseam pipe has no longitudinal seams, this criterion is not valid for this type of pipe.

8.1.3.2 For pipe fabricated with longitudinal seams (riveted or bolted) the seam strength shall be sufficient to develop the thrust in the pipe wall. The safety factor *SF* on seam strength *SS* is 3. Determine the required seam strength as follows:

$$SS = T(SF) \quad (7)$$

8.1.3.3 Check the ultimate seam strengths shown in Tables 3 and 4, or Table 5. If the required seam strength exceeds that shown for the aluminum thickness already chosen, use a heavier pipe whose seam strength exceeds the required seam strength.

## 9. Design by LRFD Method

9.1 **Factored Loads**—The pipe shall be designed to resist the following combination of factored earth load (*EL*) and live load plus impact (*LL + IL*):

$$P_L = 1.95EL + 1.75(LL + IL) \quad (8)$$

$$P_f = 1.95EL + 1.75(LL + IL) \quad (8)$$

9.2 *Factored Thrust*—The factored thrust,  $T_{Lf}$ , per unit length of wall shall be determined from the factored crown pressure  $P_{Lf}$  as follows:

$$T_L = P_L S/2 \quad (9)$$

$$T_f = P_f S/2 \quad (9)$$

9.3 *Factored Resistance*—The factored resistance ( $R_{rf}$ ) shall equal or exceed the factored thrust.  $R_{rf}$  shall be calculated for the limit states of (1) wall resistance, (2) resistance to buckling, and (3) seam resistance (where applicable) as follows:

$$R_r + \phi R_n \quad (10)$$

$$R_f = \phi R_n \quad (10)$$

The resistance factor ( $\phi$ ) shall be as specified in Table 8. The nominal resistance ( $R_n$ ) shall be calculated as specified in 9.4, 9.5, and 9.6.

9.4 *Wall Resistance*—The nominal axial resistance per unit length of wall without consideration of buckling, shall be taken as follows:

$$R_n = F_y A \quad (11)$$

$$R_n = f_y A \quad (11)$$

9.5 *Resistance to Buckling*—The wall area nominal resistance calculated using Eq 11 shall be investigated for buckling. If  $f_c < F_y$ ,  $R_n$  shall be recalculated using  $f_c$  in lieu of  $F_y$ . The value of  $f_c$  shall be determined from Eq 5 or Eq 6 as applicable.

9.6 *Seam Resistance*—For pipe fabricated with longitudinal seams, the nominal resistance of the seam per unit length of wall, shall be taken as the ultimate seam strength shown in Tables 3 and 4, or Table 5.

## 10. Handling and Installation

10.1 The pipe shall have enough rigidity to withstand the forces that are normally applied during shipment and placing. Both shop- and field-assembled pipe shall have strength adequate to withstand compaction of the sidefill without interior bracing to maintain pipe shape. Handling and installation rigidity is measured by the following flexibility requirement:

$$FF = \frac{s^2}{EI} \quad (12)$$

10.2 For curve and tangent corrugated pipe, the flexibility factor shall not exceed the following:

Depth of Corrugation, in. [mm]	Flexibility Factor, $FF$ , in./lbf [mm/N]	
	Material Thickness, in. [mm]	$FF$
¼ [6.5] and ½ [13]	0.060 [1.52]	0.031 [0.18]
	0.075 [1.91]	0.061 [0.35]
	all others	0.092 [0.53]
1 [25]	all	0.060 [0.34]
2½ [64] round pipe	all	0.025 [0.14]
2½ [64] arch and pipe arch	all	0.036 [0.21]

10.3 For ribbed pipes installed in a trench cut in undisturbed soil and provided with a soil envelope meeting the requirements of 17.2.3 to minimize compactive effort, the flexibility factor shall not exceed the following:

Depth of Rib, in. [mm]	Flexibility Factor, $FF$ , in./lbf [mm/N]
¾ [19]	0.600 <sup>1/3</sup> [0.135 <sup>1/3</sup> ]
1 [25]	0.310 <sup>1/3</sup> [0.070 <sup>1/3</sup> ]

10.4 For ribbed pipes installed in a trench cut in undisturbed soil where the soil envelope does not meet the requirements of 17.2.3, the flexibility factor shall not exceed the following:

**TABLE 8 Resistance Factors for LRFD Design**

Type of Pipe	Limit State	Resistance Factor, $\phi$
Helical pipe with lock seam or fully welded seam	Minimum wall area and buckling	1.00
	Minimum wall area and buckling	1.00
Annular pipe with spot-welded, riveted, or bolted seam	Minimum wall area and buckling	1.00
	Minimum seam strength	0.67
Structural plate pipe	Minimum wall area and buckling	1.00
	Minimum wall area and buckling	1.00
	Minimum seam strength	0.67



Depth of Rib, in. [mm]	Flexibility Factor, <i>FF</i> , in./lbf [mm/N]
¾ [19]	0.420 <sup>1/3</sup> [0.0944 <sup>1/3</sup> ]
1 [25]	0.215 <sup>1/3</sup> [0.048 <sup>1/3</sup> ]

10.5 For ribbed pipes installed in an embankment or fill section, the flexibility factor shall not exceed the following:

Depth of Rib, in. [mm]	Flexibility Factor, <i>FF</i> , in./lbf [mm/N]
¾ [19]	0.340 <sup>1/3</sup> [0.0764 <sup>1/3</sup> ]
1 [25]	0.175 <sup>1/3</sup> [0.039 <sup>1/3</sup> ]

## 11. Minimum Cover Requirements

11.1 *Minimum Cover Design*—Where pipes are to be placed under roads, streets, or freeways, the minimum cover requirement shall be determined. Minimum cover  $H_{\min}$  is defined as the distance from the top of the pipe to the top of the rigid pavement or to the top of the subgrade for flexible pavement. Maximum axle loads in accordance with AASHTO Specifications for Highway Bridges are as follows:

Class of Loading	Maximum Axle Load lbf [N]
H25	40 000 [177 900]
HS25	40 000 [177 900]
H20	32 000 [142 300]
HS20	32 000 [142 300]
H15	24 000 [106 700]
HS15	24 000 [106 700]

11.1.1 When:

$$\sqrt{\frac{(AL)d}{EI}} > 0.23 \quad \text{or} \quad < 0.45, \quad (13)$$

the minimum cover requirement is:

$$H_{\min} = 0.55S \sqrt{\frac{(AL)d}{EI}} \quad (14)$$

11.1.2 When:

$$\sqrt{\frac{(AL)d}{EI}} < 0.23 \quad \text{then} \quad H_{\min} = \frac{S}{8} \quad (15)$$

11.1.3 When:

$$\sqrt{\frac{(AL)d}{EI}} > 0.45 \quad \text{then} \quad H_{\min} = \frac{S}{4} \quad (16)$$

In all cases,  $H_{\min}$  is never less than 1 ft [300 mm].

11.2 *Minimum Cover Under Railways*—Where pipes are to be placed under railways, the minimum cover (measured from the top of the pipe to the bottom of the crossties) shall not be less than one fourth of the span for factory-made pipe, or one fifth of the span for field-bolted pipe. In all cases, the minimum cover is never less than 1 ft [300 mm] for roundpipe, or 2 ft [600 mm] for arches and pipe-arches.

11.3 *Minimum Cover Under Aircraft Runways*—Where pipes are to be placed under rigid-pavement runways, the minimum cover is 1.5 ft [450 mm] from the top of the pipe to the bottom of the slab, regardless of the type of pipe or the loading. For pipes under flexible-pavement runways, the minimum cover must be determined for the specific pipe and loadings that are to be considered; see the FAA, “Airport Drainage.”

11.4 *Construction Loads*—It is important to protect drainage structures during construction. Heavy construction equipment shall not be allowed close to or on buried pipe unless provisions are made to accommodate the loads imposed by such equipment. A minimum cover of 4 ft [1200 mm] is suggested; however, this may be modified depending on field conditions and by experience.

## 12. Deflection

12.1 The application of a deflection design criteria is optional. Long-term field experience and test results have demonstrated that corrugated aluminum pipe, properly installed using suitable fill material, will experience no significant deflection. Some designers, however, continue to apply a deflection limit.

## 13. Smooth-Line Pipe

13.1 Corrugated aluminum pipe composed of a smooth interior aluminum liner and a corrugated exterior shell that are attached integrally at the continuous helical lockseam, shall be designed in accordance with this practice on the same basis as a standard

corrugated aluminum pipe having the same corrugation as the shell and a weight per foot [metre] equal to the sum of the weights of the liner and the shell. The corrugated shell shall be limited to corrugations having a maximum pitch of 3 in. [75 mm], and a thickness of not less than 60 % of the total thickness of the equivalent standard pipe. The distance between parallel helical seams, when measured along the longitudinal axis of the pipe, shall be no greater than 30 in. [750 mm].

#### 14. Spiral-Rib Pipe

14.1 Pipe composed of a single thickness of smooth sheet with helical ribs projecting outwardly shall be designed on the same basis as a standard corrugated aluminum pipe.

#### 15. Pipe-Arch Design

15.1 Pipe-arch design shall be similar to round pipe using twice the top radius as the span  $S$ .

#### 16. Materials

16.1 Acceptable pipe materials, methods of manufacture, and quality of finished pipe are described in Specifications B 745/B 745M and B 746/B 746M.

#### 17. Soil Design

17.1 The performance of a flexible corrugated aluminum pipe is dependent on soil-structure interaction and soil stiffness.

17.2 *Soil Parameters to be Considered:*

17.2.1 The type and anticipated behavior of the foundation soil under the design load must be considered.

17.2.2 The type, compacted density, and strength properties of the soil envelope immediately adjacent to the pipe shall be established. Good sidefill material is considered to be a granular material with little or no plasticity and free of organic material. Soils meeting the requirements of Groups GM and GC as described in Classification D 2487 are generally acceptable, when compacted to 90 % of maximum density as determined by Test Method D 698. Soils meeting the requirements of Groups GW, GP, SW, and SP as described in Classification D 2487 are generally acceptable, when compacted to 95 % of maximum density as determined by Test Method D 698. Test Methods D 1556, D 2167, D 2922, and D 2937 may be used to determine the in-place density of the soil. Soil Groups SM and SC are acceptable but may require closer control to obtain the specified density.

17.2.3 Ribbed pipe covered by ~~6.2.3~~ 10.3 shall have soil envelope of clean, nonplastic materials meeting the requirements of Groups GP and SP in accordance with the classification of Classification D 2487, or well-graded granular materials meeting the requirements of Groups GW, SW, GM, SM, GC, or SC, in accordance with the classification of Classification D 2487, with a maximum plasticity index (PI) of 10. All envelope materials shall be compacted to a minimum 90 % of standard density in accordance with Test Methods D 698. Maximum loose lift thickness shall be 8 in. [200 mm].

NOTE 2—Soil cement or cement slurries may be used instead of the select granular materials.

17.2.4 The size of the structural soil envelope shall be 2 ft [600 mm] minimum each side for trench installations and one diameter minimum each side for embankment installations. This structural soil envelope shall extend at least 1 ft [300 mm] above the top of the pipe.

17.3 *Pipe-Arch Soil-Bearing Design*—The pipe-arch shape causes the soil pressure at the corner to be very high compared to the soil pressure across the top of the pipe-arch. The bearing capacity of the soil at the pipe-arch corner usually limits the maximum depth of fill over a pipe-arch. Determine the maximum height of fill as follows:

$$H_{\max} = \frac{66.7r_c}{S} \quad (\text{for } 2 \text{ tons/ft}^2 \text{ of soil bearing pressure}) \quad (17)$$

$$H_{\max} = \frac{20.3r_c}{S} \quad (\text{for } 190 \text{ kPa of soil bearing pressure}) \quad (18)$$

Bedding and backfill material at the corner of pipe-arches placed on a stable foundation shall have an allowable bearing pressure of 2 tons/ft<sup>2</sup> [190 kPa]. Corner pressures in excess of 2 tons/ft<sup>2</sup> [190 kPa] require a special design.

#### 18. Minimum Spacing

18.1 When multiple lines of pipes or pipe-arches greater than 48 in. [1200 mm] in diameter or span are used, they shall be spaced so that the sides of the pipe shall be no closer than one half of a diameter or 3 ft [900 mm], whichever is less, so that sufficient space for adequate compaction of the fill material is available. For diameters up to 48 in. [1200 mm], the minimum distance between the sides of the pipes shall be no less than 2 ft [600 mm].

18.2 Materials such as various foamed or cementitious materials that set up without mechanical compaction, may be placed between structures with as little as 6 in. [150 mm] of clearance.

#### 19. End Treatment

19.1 Protection of end slopes shall require special consideration where backwater conditions may occur or where erosion and uplift could be a problem.

19.2 End walls designed on a skewed alignment require special design.

## 20. Abrasive or Corrosive Conditions

20.1 Extra aluminum thickness or coatings may be required for resistance to corrosion or abrasion, or both. For highly abrasive conditions, special designs may be required.

## 21. Construction and Installation

21.1 The construction and installation of corrugated aluminum pipe and pipe-arches and aluminum structural plate pipe, pipe-arches, and arches shall conform to Practices B 788/B 788M and B789/B 789M.

## 22. Structural Plate Arches

22.1 The design of structural plate arches shall be based on a minimum ratio of rise to span of 0.3; otherwise, the structural design is the same as for structural plate pipe.

### 22.2 Footing Design:

22.2.1 The load transmitted to the footing is considered to act tangential to the aluminum plate at its point of connection to the footing. The load is equal to the thrust in the aluminum arch plate.

22.2.2 The footing shall be designed to provide for settlement of an acceptable magnitude uniformly along the longitudinal axis. Providing for the arch to settle will protect it from possible overload forces induced by the settling of adjacent embankment fill.

22.2.3 Where poor materials are encountered that might settle excessively, some of this poor material shall be removed and replaced with acceptable material.

22.2.4 It is undesirable to make the aluminum arch relatively unyielding or fixed compared to the adjacent sidefill. The use of massive footings or piles to prevent settlement of the arch is generally not required, or is it desired.

22.2.5 Invert slabs or other appropriate methods should be provided when scour is anticipated.

## 23. Keywords

23.1 aluminum culvert; aluminum storm drains; structural design; culvert pipe; structural design; storm drains

## SUMMARY OF CHANGES

Committee B07 has identified the location of selected changes to this standard since B 790/B 790M–99 that may impact the use of this standard.

(1) This revision is to bring the material design strength levels into compliance with the current values given in B 746/B 746M, B 209, and B 209M.

(2) In general, changes have been made to bring this specification into line with its coated steel counterpart A 796/A 796M “Standard Practice for Structural Design of Corrugated Steel Pipe, Pipe-Arches, and Arches for Storm and Sanitary Sewers and Other Buried Applications”.

(3) General revisions have been made to grammar and terminology.

(4) Some symbol subscripts have been revised to reflect their meaning. The list of symbols is now presented alphabetically. Symbols have been revised throughout the practice to reflect the changes in subscripts and corrections to symbols so that they appear as they are listed in the list of symbols.

(5) Eq 10 has been corrected.

(6) Paragraph 9.5 has been revised so that nominal axial resistance is investigated, rather than the wall area of the chosen corrugation. The correct equation is now referenced.

(7) The figures that accompany section property Tables 1-7, showing corrugation dimensions, have been cleaned up.

*ASTM International takes no position respecting the validity of any patent rights asserted in connection with any item mentioned in this standard. Users of this standard are expressly advised that determination of the validity of any such patent rights, and the risk of infringement of such rights, are entirely their own responsibility.*

*This standard is subject to revision at any time by the responsible technical committee and must be reviewed every five years and if not revised, either reapproved or withdrawn. Your comments are invited either for revision of this standard or for additional standards and should be addressed to ASTM International Headquarters. Your comments will receive careful consideration at a meeting of the responsible technical committee, which you may attend. If you feel that your comments have not received a fair hearing you should make your views known to the ASTM Committee on Standards, at the address shown below.*

*This standard is copyrighted by ASTM International, 100 Barr Harbor Drive, PO Box C700, West Conshohocken, PA 19428-2959, United States. Individual reprints (single or multiple copies) of this standard may be obtained by contacting ASTM at the above address or at 610-832-9585 (phone), 610-832-9555 (fax), or service@astm.org (e-mail); or through the ASTM website (www.astm.org).*