



Designation: B 213 – 9703

Standard Test Method for Flow Rate of Metal Powders¹

This standard is issued under the fixed designation B 213; the number immediately following the designation indicates the year of original adoption or, in the case of revision, the year of last revision. A number in parentheses indicates the year of last reapproval. A superscript epsilon (ϵ) indicates an editorial change since the last revision or reapproval.

1. Scope

1.1 This test method covers the determination of the flow rate of metal powders and is suitable only for those powders that will flow unaided through the specified apparatus.

1.2 The values stated in SI units are to be regarded as the standard (except for the flowmeter funnel, which is fabricated in inch-pound units). The values given in parentheses are for information only.

1.3 *This standard does not purport to address all of the safety concerns, if any, associated with its use. It is the responsibility of the user of this standard to establish appropriate safety and health practices and determine the applicability of regulatory limitations prior to use.*

2. Referenced Documents

2.1 *ASTM Standards:*

¹ This test method is under the jurisdiction of ASTM Committee ~~B-9~~ B09 on Metal Powders and Metal Powder Products and is the direct responsibility of B09.02 on Base Metal Products—Powders.

Current edition approved Sept. 10, 1997; Oct. 1, 2003. Published March 1998; October 2003. Originally published as B 213 – 46T; approved in 1946. Last previous edition approved in 1997 as B 213 – 967.

B 215 Practices for Sampling Finished Lots of Metal Powders²
 B 243 Terminology of Powder Metallurgy²

3. Terminology

3.1 *Definitions* —Definitions of powder metallurgy terms can be found in Terminology B 243.

3.2 *Definitions of Terms Specific to This Standard:*

3.2.1 *flow rate, n*—the time required for a powder sample of standard mass to flow through an orifice in a standard instrument according to a specified procedure.

4. Summary of Test Method

4.1 A weighed mass (50.0 g) of metal powder is timed as it flows through the calibrated orifice of a funnel.

5. Significance and Use

5.1 The rate and uniformity of die cavity filling are related to flow properties, which thus influence production rates and uniformity of compacted parts.

5.2 The ability of a powder to flow is a function of interparticle friction. As interparticle friction increases, flow is slowed. Fine powders may not flow.

5.3 Humidity and moisture content influence flow rate. Wet or moist powders may not flow.

5.4 This test method may be part of the purchase agreement between powder manufacturers and powder metallurgy (P/M) part producers, or it can be an internal quality control test by either the producer or the end user.

6. Apparatus

6.1 *Powder Flowmeter Funnel*³—A flowmeter funnel (Fig. 1) having a calibrated orifice of 0.10 in. (2.54 mm) in diameter.

NOTE 1—The dimensions shown for the flowmeter funnel, including the orifice, are not to be considered controlling factors. Calibration with emery, as specified in Section 9, determines the working flow rate of the funnel.

² Annual Book of ASTM Standards, Vol 02.05.

³ The flowmeter funnel, stand, and Chinese emery are available from AcuPowder International, LLC.

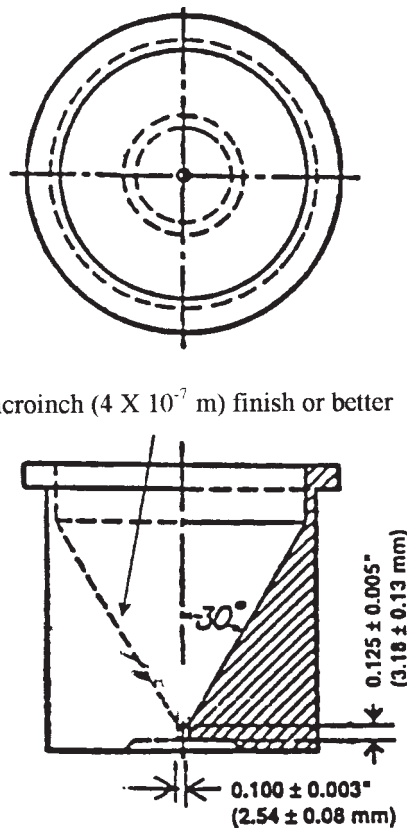

FIG. 1 Flowmeter Funnel

- 6.2 *Stand*³—A stand (Fig. 2) to support the powder flowmeter funnel.
- 6.3 *Base*—A level, vibration free base to support the powder flowmeter stand.
- 6.4 *Timing Device*—A stopwatch or other suitable device capable of measuring to the nearest 0.1 s.
- 6.5 *Chinese Emery*³—An emery powder used to calibrate the flowmeter funnel.
- 6.6 *Balance*—A balance suitable for weighing at least 50.0 g to the nearest 0.1 g.

7. Sampling

7.1 A quantity of powder sufficient to run the desired number of flow tests shall be obtained in accordance with Practices B 215.

8. Preparation of Apparatus

- 8.1 Clean the funnel with clean dry toweling paper.
- 8.2 Clean the funnel orifice with a clean dry pipe cleaner.

9. Calibration of Apparatus

9.1 The manufacturer supplies the powder flowmeter funnel calibrated as follows:

9.1.1 Heat an open glass jar of Chinese emery in a drying oven at a temperature of 102° to 107°C (215° to 225°F) for 1 h.

9.1.2 Cool the emery to room temperature in a dessicator.

9.1.3 Follow the procedure outlined in steps 10.1.1-10.1.8 .

9.1.4 Repeat steps 10.1.2-10.1.8 using the identical 50.0 g mass of emery for all the tests until 5 flow times, the extremes of which shall not differ by more than 0.4 s, have been recorded.

NOTE 2—The flow rate of Chinese emery calibration powder is sensitive to moisture. Starting from the dried condition, it will absorb moisture from the ambient air as five (or more) flow tests are performed. Flow times can vary dependent upon the humidity of the test area.

9.1.5 The average of these five flow times is stamped on the bottom of the funnel.

9.2 The flow rate of Chinese emery powder was established by an interlaboratory study conducted by Subcommittee B09.02 in 1995.⁴ It represents the flow rate through the master flowmeter funnel that had been used in a previous interlaboratory study with the former Turkish emery calibration powder, which is no longer available.

9.3 It is recommended that the flow rate be checked periodically, at least every six months, using the procedure outlined in steps 9.1.1-9.1.5. If the flow rate has changed from that stamped on the instrument, the new correction factor will be 40.0 divided by

⁴ Supporting data is available from ASTM Headquarters.

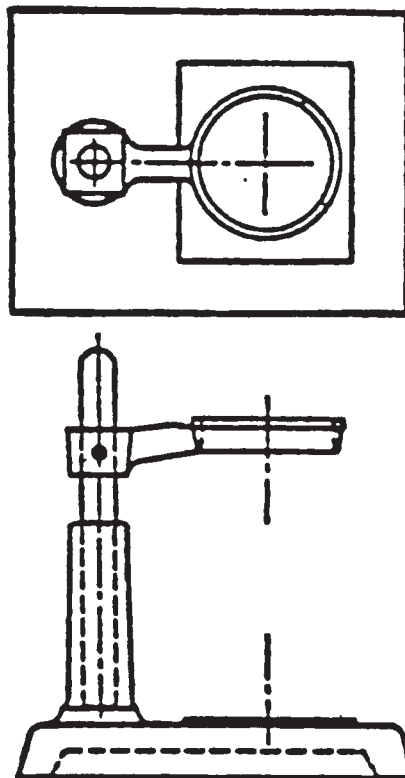

FIG. 2 Stand

this new flow rate. Before adopting the new correction factor, however, it is recommended that the cause of the change be investigated. If the flow rate has increased (faster flow), it is probable that repeated use has burnished the orifice and the new correction factor may be used. A decrease in flow rate (slower flow) may indicate a plating of soft powder upon the orifice. This should be removed carefully with the aid of a pipe cleaner and the calibration test rerun, the new correction factor being calculated if required. It is recommended that the use of a funnel be discontinued after the flow rate of the emery has increased such that the time of flow is less than 37 s.

10. Procedure

10.1 Method 1—Stationary Powder Start to Flow Measurement:

- 10.1.1 Weigh out a 50.0 g mass of powder, as sampled, into a clean weighing dish.
- 10.1.2 Block the discharge orifice at the bottom of the funnel with a dry finger.
- 10.1.3 Carefully pour the 50.0 g sample of powder into the center of the flowmeter funnel without any tapping, vibration or movement of the funnel.
- 10.1.4 Place the emptied weighing dish on the flowmeter stand directly under the funnel orifice.
- 10.1.5 Simultaneously start the stopwatch and remove your finger from the discharge orifice.
- 10.1.6 If the powder fails to start flowing, one light tap on the funnel rim is permitted. Further tapping of the funnel, however, or poking or stirring of the powder in the funnel with a wire or any other implement is not permitted.
- 10.1.7 Stop the stopwatch the instant the last of the powder exits the orifice.
- 10.1.8 Record the elapsed time to the nearest 0.1 s.
- 10.1.9 More than one flow may be run if desired. Use a fresh 50.0 g quantity of powder for each flow test. Average the flow times.

10.2 Method 2—Moving Powder Start to Flow Measurement:

- 10.2.1 Place an empty receptacle directly under the discharge orifice.
- 10.2.2 Weigh out a 50.0 g mass of powder, as sampled, into a clean weighing dish.
- 10.2.3 Pour the 50.0 g powder specimen into the center of the funnel and start the stopwatch the instant the powder exits the orifice.
- 10.2.4 Stop the stopwatch the instant the last of the powder exits the orifice.
- 10.2.5 Record the elapsed time to the nearest 0.1 s.
- 10.2.6 More than one flow may be run if desired. Use a fresh 50.0 g quantity of powder for each flow test. Average the flow times.

11. Calculation

- 11.1 Calculate the correction factor by dividing 40.0 by either the flow rate stamped on the bottom of the funnel, or the new calibration flow rate established in 9.3.
- 11.2 Multiply the elapsed time (see 10.1.9 or 10.2.6) by the desired correction factor (see 11.1).

12. Report

- 12.1 Report the corrected flow rate in seconds to the nearest second.

13. Precision and Bias

13.1 *Precision*—Precision has been determined from an interlaboratory study performed by seven laboratories of Subcommittee B09.02.⁴

13.1.1 Repeatability intervals, r , are listed in Table 1. In 95 % of flow rate determinations, on the basis of test error alone, duplicate tests in the same laboratory by the same operator on one homogeneous lot of powder will differ by no more than the stated amount in seconds.

13.1.2 Reproducibility intervals, R , are listed in Table 1. For 95 % of comparative trials done in two different laboratories, and on the basis of test error alone, single tests on the same homogeneous lot of powder will differ by no more than the stated amount in seconds.

TABLE 1 Precision of Flow Rate Measurements of Metal Powders

Powder	Apparent Density (g/cm ³)	Flow Rate × Avg. (s/50 g)	Repeatability (r) Avg. 3 Flows (s)	Reproducibility (R) Avg. 3 Flows (s)
Spherical bronze	5.04	12	0.1	0.8
Iron #1	2.46	31	0.7	2.5
Iron #2	3.03	26	1.0	2.1
Iron (lubricated)	3.18	26	1.3	2.2
Bronze premix (lubricated)	3.31	31	1.7	2.6
Brass (lubricated)	3.61	42	4.1	8.7

13.2 *Bias*—No statement can be made about bias, because there is no standard reference material for flow rate measurement.

14. Keywords

14.1 flow rate; metal powder flow; powder flow

ASTM International takes no position respecting the validity of any patent rights asserted in connection with any item mentioned in this standard. Users of this standard are expressly advised that determination of the validity of any such patent rights, and the risk of infringement of such rights, are entirely their own responsibility.

This standard is subject to revision at any time by the responsible technical committee and must be reviewed every five years and if not revised, either reapproved or withdrawn. Your comments are invited either for revision of this standard or for additional standards and should be addressed to ASTM International Headquarters. Your comments will receive careful consideration at a meeting of the responsible technical committee, which you may attend. If you feel that your comments have not received a fair hearing you should make your views known to the ASTM Committee on Standards, at the address shown below.

This standard is copyrighted by ASTM International, 100 Barr Harbor Drive, PO Box C700, West Conshohocken, PA 19428-2959, United States. Individual reprints (single or multiple copies) of this standard may be obtained by contacting ASTM at the above address or at 610-832-9585 (phone), 610-832-9555 (fax), or service@astm.org (e-mail); or through the ASTM website (www.astm.org).