



Standard Test Method for Green Strength for Compacted Metal Powder Specimens¹

This standard is issued under the fixed designation B 312; the number immediately following the designation indicates the year of original adoption or, in the case of revision, the year of last revision. A number in parentheses indicates the year of last reapproval. A superscript epsilon (ϵ) indicates an editorial change since the last revision or reapproval.

1. Scope

1.1 This test method covers determination of the green strength of unsintered compacted metal powder specimens by subjecting them to a uniformly increasing transverse loading under controlled conditions. The term green strength, as used herein, defines the stress, calculated from the flexure formula, required to break a specimen as a simple beam supported near the ends and applying the force midway between the fixed line center of the supports.

1.2 The values stated in inch-pound units are to be regarded as the standard. The SI equivalents are in parentheses and may be approximate.

1.3 *This standard does not purport to address all of the safety concerns, if any, associated with its use. It is the responsibility of the user of this standard to establish appropriate safety and health practices and determine the applicability of regulatory limitations prior to use.*

2. Referenced Documents

2.1 *ASTM Standards:*

B 243 Terminology of Powder Metallurgy²

3. Terminology

3.1 Definitions of powder metallurgy (P/M) terms can be found in Terminology B 243. Additional descriptive information is available in the Related Material section of Vol 02.05 of the *Annual Book of ASTM Standards*.

4. Summary of Test Method

4.1 The powder to be tested is pressed in a die to the configuration of a bar having a standard rectangular shape in the pressing direction and to one of two thicknesses. Either the powder to be pressed contains lubricant or the surfaces of the die are lubricated at each pressing.

4.2 The pressed test specimen's width, thickness, and density are determined. The load necessary to fracture the bar is determined by applying a uniformly increasing force to the specimen while supporting it in the prescribed three-point bend test fixture.

4.3 Green strength or maximum fiber stress of the material under test is determined by calculation using the equation for a simply supported beam with a concentrated load.

5. Significance and Use

5.1 The test for green strength of a compacted metal powder is useful as a:

5.1.1 Method to relate the resistance of a pressed compact to breakage or damage due to handling.

5.1.2 Means of quality comparison of metal powder, lot to lot.

5.1.3 Method of determining the effect of additions to a base powder.

5.2 Significant variations in green strength will occur if the density tolerance of the pressed bar is exceeded.

6. Apparatus

6.1 *Punches and Die* (see Fig. 1), for producing a test specimen having a nominal die dimension of 0.500 in. (12.70 mm) wide by 1.250 in. (31.75 mm) long.

6.2 *Compression Testing Machine or Powder Press*, capable of applying the required pressure to produce, and break if desired, the standard test specimen.

6.3 *Balance*, suitable for weighing to an accuracy of 0.01 g.

6.4 *Micrometers*, capable of measuring from 0.0 to 1.25 in. (0.0 to 31.8 mm) with an accuracy of 0.001 in. (0.03 mm).

6.5 Either of the following testing apparatus:

6.5.1 *Constant Loading Beam Device* as shown in Fig. 2, capable of measuring the breaking force on the test specimen to the nearest 0.1 lbf (0.5 N).

6.5.2 *Transverse Rupture Test Fixture* as shown in Fig. 3, for use with a compression testing machine to locate the test bar so the breaking force can be measured to the nearest 0.1 lbf (0.5 N).

7. Test Specimen

7.1 The test specimen has nominal dimensions of 0.500 in. (12.70 mm) wide by 1.250 in. (31.75 mm) long by either 0.250 in. (6.35 mm) or 0.500 in. (12.70 mm) thick. The green density shall be within ± 0.05 g/cm³ of the target.

8. Procedure

8.1 For lubricated powders follow the instructions starting in Section 8.2. The method of lubrication of the powders shall

¹ This test method is under the jurisdiction of ASTM Committee B-9 on Metal Powders and Metal Powder Products and is the direct responsibility of Subcommittee B09.02 on Base Metal Powders.

Current edition approved Sept. 10, 1996. Published December 1996. Originally published as B 312 – 56 T. Last previous edition B 312 – 82 (1988) ^{ϵ 1}.

² *Annual Book of ASTM Standards*, Vol 02.05.

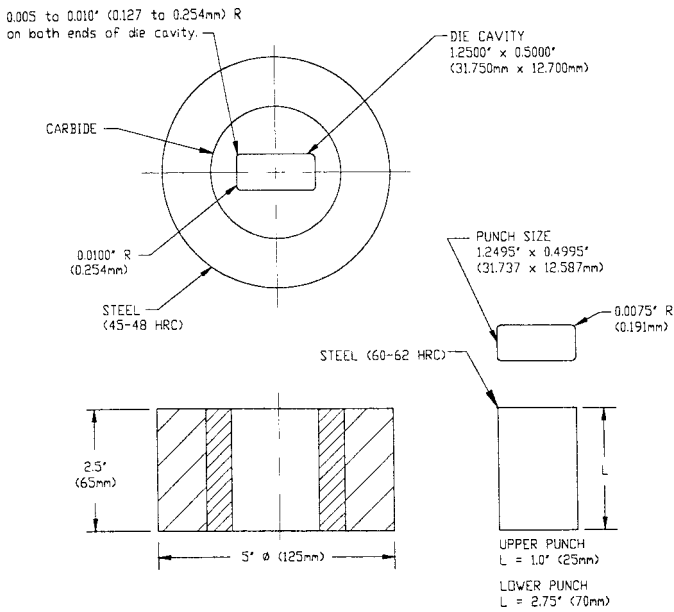

NOTE 1—The dimensions for the cavity shall be 0.500 ± 0.004 in. wide (12.70 ± 0.10 mm) by 1.250 ± 0.004 in. long (31.75 ± 0.10 mm). The mating parts shall fit freely and should be finished to a 4 μ m. (N3) or better to dimensions of 0.0005 in. (0.013 mm) to 0.0010 in. (0.025 mm) smaller than the die cavity in each dimension. The dimensions given in the drawing typify the die cavity and punch within the stated tolerance at the normal width and length.

FIG. 1 Example of Tooling to Produce the Test Specimen

be standardized since green strength, green density, and compactibility will vary with the method chosen and the care with which it is applied. The method of lubrication shall be a matter of agreement between the parties concerned. Unlubricated powder may be tested in a die with lubricated walls. Apply to the die walls a lubricant mixture (for example, a mixture of 100 g of zinc stearate in one liter of methyl alcohol. Warning: This mixture is flammable and should be used in a suitable, well ventilated area.) After any excess liquid has drained away, allow the die walls to dry, and fill with the powder being tested, as described in 8.2 and 8.3.

8.2 Determine from Table 1 the approximate mass of powder to be used to make a test specimen 0.250 ± 0.005 in. (6.35 ± 0.13 mm) or 0.500 ± 0.005 in. (12.7 ± 0.13 mm) thick by 0.500 in. (12.7 mm) wide by 1.250 in. (31.7 mm) long. See Fig. 4. Weigh this charge to ± 0.02 g.

8.3 The specimen is prepared using a double action pressing process. One example of this type of compaction is as follows: With the lower punch inserted in the die cavity, pour the powder into the die cavity taking care that the powder is uniformly distributed. Apply pressure from both ends by means of the following arrangement: Insert the upper punch, and place the die, supported on two spacers, between the platens of the press. Apply a preliminary pressure of 5000 psi (34 MPa) to the upper punch, while the die barrel is supported by the spacers; then release the pressure and remove the spacers. With the spacers removed, apply the final compacting pressure at a rate of $60\,000 \pm 5000$ psi (414 ± 34 MPa)/min.

8.4 Use a compacting pressure that will produce the correct thickness of 0.250 ± 0.005 in. (6.35 ± 0.13 mm) or $0.500 \pm$

0.005 in. (12.7 ± 0.13 mm).

8.5 After ejection from the die, weigh the specimen to the nearest 0.01 g, measure the specimen dimensions to the nearest 0.001 in. (0.03 mm), and identify the top of the specimen. Calculate the density of the green specimen. If the specimen density is within the tolerance, place the specimen in the transverse rupture test fixture or the constant loading beam device perpendicular to the supporting rods with the top uppermost. In the case of the transverse rupture test fixture, place the loaded fixture between the platens of the compression testing machine set for an initial crosshead velocity of approximately 0.1 in./min and apply a uniformly increasing force at a rate of approximately 20 lbf (89 N)/min until rupture occurs. Record the breaking force in lbf (or N) to the nearest 0.1 lbf (0.5 N). When using the constant loading beam device (Fig. 2), shot is allowed to flow into a suitable container at a rate that will produce approximately 20 lbf (89 N)/min on the specimen. The mass of the shot is determined to the nearest gram (0.0022 lb) and the breaking force in lbf (or N) is calculated to the nearest 0.1 lbf (0.5 N) as follows:

$$P = AX/B \quad (1)$$

where:

P = force on test specimen, lbf (N),

A = length A, in. (mm),

B = length B, in. (mm), and

X = mass of shot, lb (kg) to the nearest 0.0022 lb (1 g) required to rupture.

9. Calculations

9.1 Calculate the green strength as follows:

$$S = \frac{3PL}{2t^2w} \quad (2)$$

where:

S = green strength, psi (MPa),

P = force required to rupture, lbf (N),

L = length of specimen span of fixture, in. (mm),

w = width of specimen, in. (mm), and

t = thickness of specimen, in. (mm).

10. Report

10.1 The green strength shall be reported in pounds-force per square inch (or megapascals) as the average of three individual results to the nearest 100 psi (or .5 MPa). The average green density shall always be reported with the green strength. The nominal thickness of the test specimen should be indicated where necessary for clarity. The lubrication method shall also be reported.

11. Precision and Bias³

11.1 The following criteria should be used to judge acceptability of individual results at the 95 % confidence level for the 0.250 in. thick specimen. Repeatability and reproducibility data for the 0.500 in. specimen are not available.

NOTE 1—This precision statement is different from the statements in other B-9 test methods because it describes the repeatability and reproducibility of individual values, not the averages of groups of test values.

³ Supporting data are available from ASTM Headquarters.

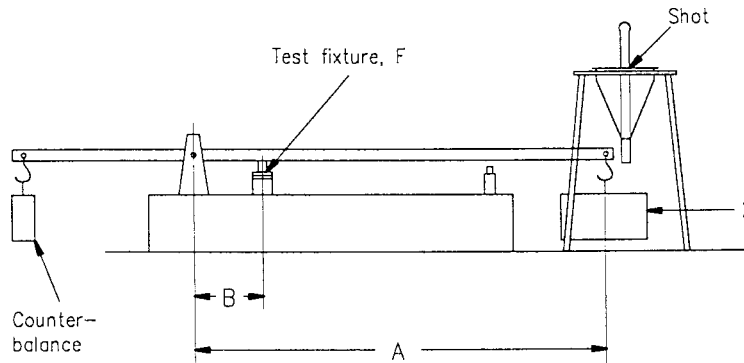

FIG. 2 Example of Constant Loading Beam Device

TABLE 1 Mass of Powder to Obtain Green Density for Test Specimen

Green Density, g/cm ³	Mass of Powder, g	
	For 0.250 in. Thickness	For 0.500 in. Thickness
6.0	15.5	31.0
6.2	16.0	32.0
6.4	16.5	33.0
6.6	17.0	34.0
6.8	17.5	35.0
7.0	18.0	36.0
7.2	18.5	37.0
7.4	19.0	38.0
7.6	19.5	39.0

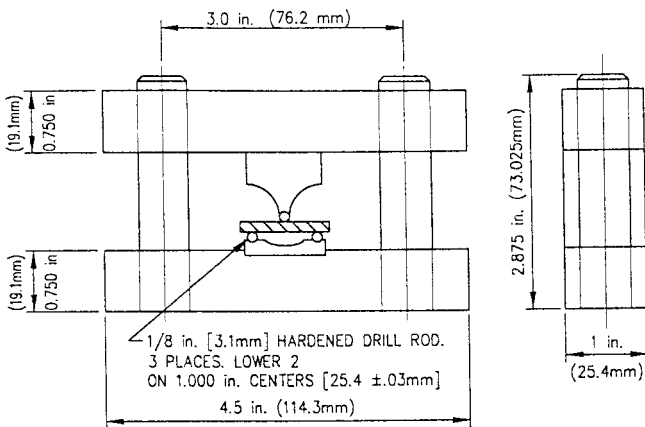

FIG. 3 Transverse Rupture Test Fixture

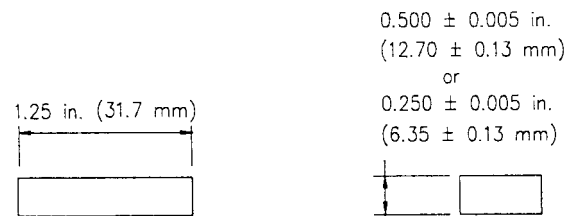

FIG. 4 Transverse Rupture Test Specimen

11.1.1 The repeatability interval, r , is estimated by the following equation: $r = 0.037 S + 78$, where S = green strength, (psi). Duplicate individual results by the same operator should be considered suspect if they differ by more than r .

11.1.2 The reproducibility interval, R , is estimated by the following equation: $R = 0.13 S + 220$. The individual results obtained by each of two laboratories should not be considered suspect unless they differ by more than R .

11.2 The bias of the green strength test can not be established because there is no standard available for comparison.

12. Keywords

12.1 constant loading beam device; green strength; P/M; powder metallurgy; unsintered compact

The American Society for Testing and Materials takes no position respecting the validity of any patent rights asserted in connection with any item mentioned in this standard. Users of this standard are expressly advised that determination of the validity of any such patent rights, and the risk of infringement of such rights, are entirely their own responsibility.

This standard is subject to revision at any time by the responsible technical committee and must be reviewed every five years and if not revised, either reapproved or withdrawn. Your comments are invited either for revision of this standard or for additional standards and should be addressed to ASTM Headquarters. Your comments will receive careful consideration at a meeting of the responsible technical committee, which you may attend. If you feel that your comments have not received a fair hearing you should make your views known to the ASTM Committee on Standards, 100 Barr Harbor Drive, West Conshohocken, PA 19428.