



## Standard Test Method for Apparent Density of Metal Powders and Compounds Using the Scott Volumeter<sup>1</sup>

This standard is issued under the fixed designation B 329; the number immediately following the designation indicates the year of original adoption or, in the case of revision, the year of last revision. A number in parentheses indicates the year of last reapproval. A superscript epsilon ( $\epsilon$ ) indicates an editorial change since the last revision or reapproval.

*This standard has been approved for use by agencies of the Department of Defense.*

<sup>ε1</sup> NOTE—Figure 2 was editorially updated in June 2003.

### 1. Scope

1.1 This test method covers determination of the apparent density of metal powders and related compounds using the Scott Volumeter, also known as the Paint Pigment Volumeter.

1.2 The values stated in SI units are to be regarded as the standard. The values given in parentheses are for information only.

1.3 *This standard does not purport to address all of the safety concerns, if any, associated with its use. It is the responsibility of the user of this standard to establish appropriate safety and health practices and determine the applicability of regulatory limitations prior to use.*

### 2. Referenced Documents

#### 2.1 ASTM Standards:

B 215 Practices for Sampling Finished Lots of Metal Powders<sup>2</sup>

B 243 Terminology of Powder Metallurgy<sup>2</sup>

B 873 Test Method for Measuring Volume of Apparent Density Cup Used in Test Methods B 212, B 329 and B 417<sup>2</sup>

### 3. Terminology

3.1 Definitions—For definitions of terms used in this test method see Terminology B 243.

### 4. Significance and Use

4.1 This test method covers the evaluation of the apparent density physical characteristic of powders. The degree of correlation between the results of this test and the quality of powders in use will vary with each particular application and has not been fully determined.

4.2 The apparent density measured via this test method is often referred to as the “Scott Density.”

### 5. Apparatus

5.1 Fig. 1 shows the Scott Volumeter<sup>3</sup> consisting of the following parts:

5.1.1 *Top Brass Funnels*—A large funnel with a 16-mesh brass screen and a small conical funnel for directing the powder into the baffle box (Note 2).

5.1.2 *Baffle Box*—A box with two glass sides and two wooden sides containing a series of four glass baffle plates.

NOTE 1—The wooden baffle box may be substituted by a water-resistant material if washing is more desirable than air cleaning.

5.1.3 *Bottom Brass Funnel*—A small brass funnel directly beneath lower baffle box opening for directing the powder into the density cup (Note 2).

5.1.4 *Brass Density Cups*—A cylindrical cup having a capacity of  $25.00 \pm 0.03 \text{ cm}^3$ , with an inside diameter of  $28.00 \pm 0.50 \text{ mm}$ ; or a square cup with a capacity of  $16.39 \pm 0.05 \text{ cm}^3 (1.000 \pm 0.003 \text{ in.}^3)$ .<sup>4</sup>

NOTE 2—Replacement parts for 5.1.1, 5.1.3, and 5.1.4 may be of stainless steel.

5.1.5 *Stand*—A 90° pivoting wooden stand to support the funnels and the baffle box concentric with the density cup so that the bottom funnel lower opening is 19 mm ( $\frac{3}{4}$  in.) above the top of the density cup as shown in Fig. 1 when using the cubic inch cup. Fig. 2 shows some suggested modifications for use of the metric cup. Modifications A and C of Fig. 2 are suggested when the metric cup is to be used exclusively. Modification B of Fig. 2 is suggested when both cups are to be used interchangeably.

<sup>1</sup> This test method is under the jurisdiction of ASTM Committee B09 on Metal Powders and Metal Powder Products and is the direct responsibility of Subcommittee B09.03 on Refractory Metal Powders.

Current edition approved April 10, 2003. Published June 2003. Originally approved in 1958. Last previous edition approved in 1998 as B 329 – 98.

<sup>2</sup> *Annual Book of ASTM Standards*, Vol 02.05.

<sup>3</sup> Apparatus may be purchased as the “Metal Powder Volumeter” (Catalog No. 66062-620) from VWR Scientific Co., 1310 Goshen Parkway, West Chester, PA 19380. The apparatus was formerly known as the “Scott, Schaeffer and White Paint Pigment Volumeter.”

<sup>4</sup> Metric cup may be constructed or purchased from Alcan Powders and Pigments, Division of Alcan Aluminum Corp., 901 Lehigh Ave., Union, NJ 07083-7632.

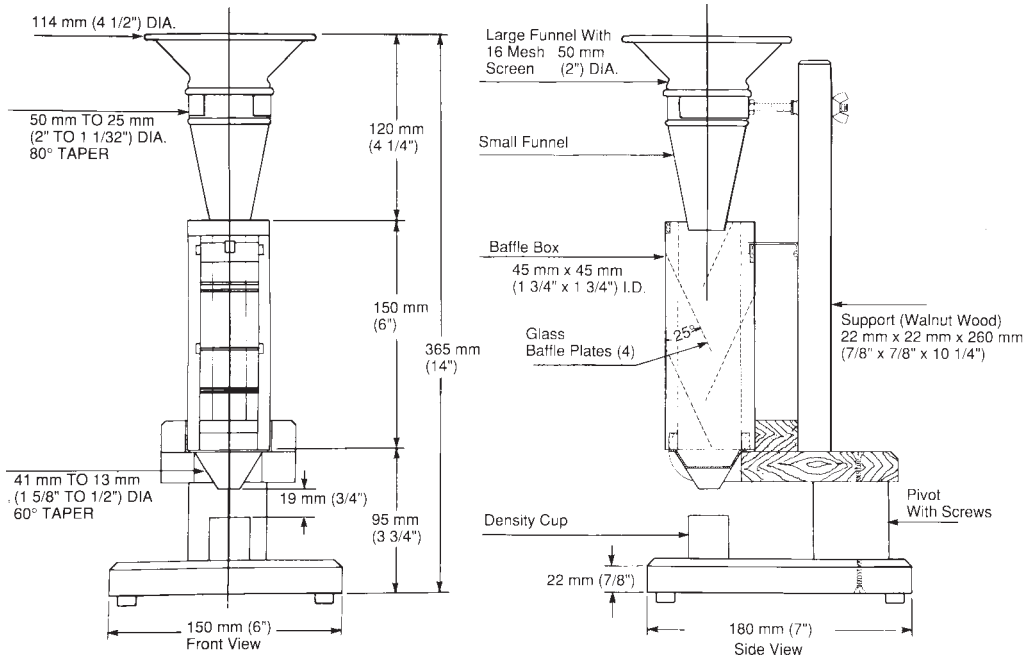
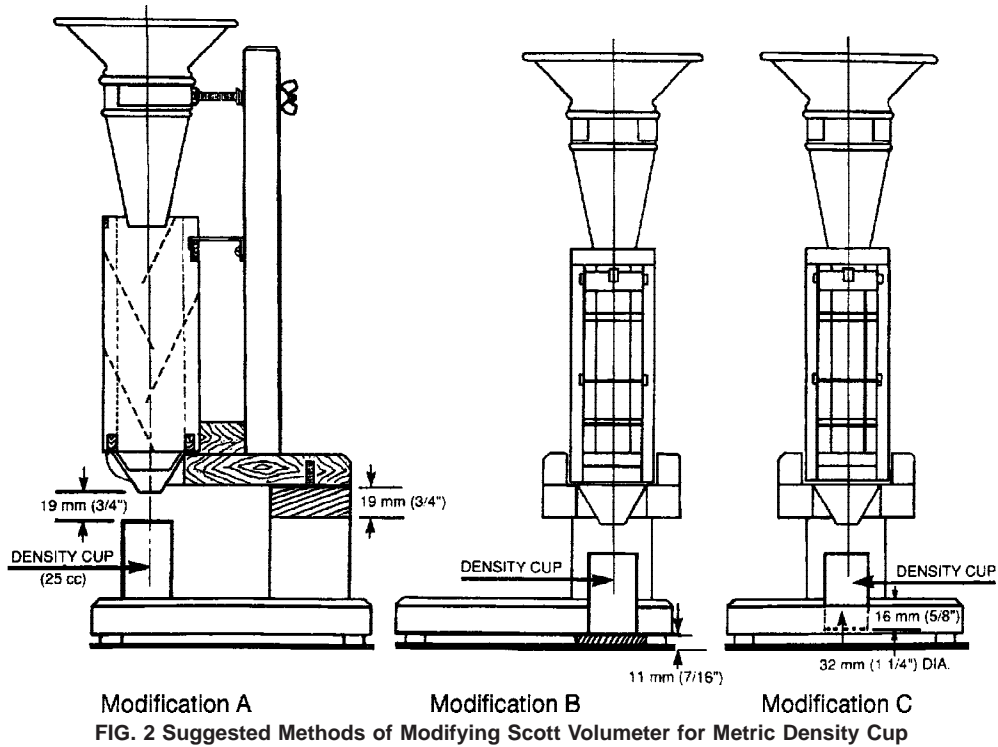

FIG. 1 Density Apparatus Assembly



Modification A                      Modification B                      Modification C  
 FIG. 2 Suggested Methods of Modifying Scott Volumeter for Metric Density Cup

5.2 *Instrument Support*—A stand or bench surface, level and vibration free.

5.3 *Balance*—A balance having a capacity of at least 200 g and an accuracy of  $\pm 0.05$  g with full-range taring capability.

5.4 *Brush*—A good quality, 25.4-mm (1-in.) wide brush, preferably nylon.

5.5 *Spatula*—A standard 12.7-mm ( $\frac{1}{2}$  -in.) wide stainless steel laboratory spatula.

## 6. Test Specimen

6.1 Obtain a test specimen in accordance with Practice B 215.

6.2 A minimum of 25 cm<sup>3</sup>(1.5 in.<sup>3</sup>) of powder for the square cup and 35 cm<sup>3</sup>(2.0 in.<sup>3</sup>) of powder for the cylindrical cup will be needed.

## 7. Calibration and Standardization

7.1 The density cups shall be calibrated in accordance with ASTM Test Method B 873.

## 8. Procedure

8.1 Tare or preweigh the density cup.

8.2 Pour the powder being tested carefully into the top receiving funnel and permit the powder to run into the density cup. Completely fill the density cup to overflowing or fill to overflowing and form a mound of powder above the top of the density cup. If the powder is not free-flowing, carefully brush the sample through the top receiving funnel screen without jarring the volumeter. Jarring of the volumeter could result in packing of the powder in the density cups, thus giving erroneously high values.

8.3 Remove the excess powder in the density cup by passing the edge of the spatula blade parallel to, and in contact with, the top of the cup. Move the spatula smoothly along the top surface of the cup and back again until all excess powder has been removed, special care being taken to direct the excess powder into the unfilled areas of the cup. It is important that the spatula be kept level at all times to prevent packing or pulling out of the powder. Perform the completed leveling operation to produce a uniform powder surface perfectly level with the top of the density cup.

8.4 After the leveling operation, lightly tap the side of the density cup to settle the powder to avoid spilling while transferring the cup to the balance for weighing.

8.5 Determine the mass of the powder to the nearest 0.1 g by weighing the cup plus powder and, if preweighed and not tared, subtracting the mass of the cup.

## 9. Calculation

9.1 Divide the mass of the powder by the volume of the cup to obtain the apparent density.

## 10. Report

10.1 Report test results as “Scott Density” or “Apparent Density, Scott” in grams per cubic centimetre to the nearest 0.1 g/cm<sup>3</sup>.

NOTE 3—If the square cup is used, multiply the result obtained in grams per cubic inch by 0.0610 for conversion to grams per cubic centimetre.

10.2 Report which density cup was used in the test.

10.3 Include a reference to this test method in the report.

## 11. Precision and Bias

11.1 *Precision*—Precision has been determined from round-robin testing performed prior to the approval of this test method. Those results, which have been re-verified, show a precision of from  $\pm 3$  to 7 % of the value determined as the 2  $\sigma$  limits for powders with apparent densities of <1 to 5 g/cm<sup>3</sup>.

11.2 *Bias*—Bias cannot be stated since there is no universally accepted standard instrument, nor are there certified standards available.

## 12. Keywords

12.1 apparent density; bulk density; Paint Pigment Volumeter; powder metallurgy; powders; refractory metals; Scott density; Scott Volumeter

*ASTM International takes no position respecting the validity of any patent rights asserted in connection with any item mentioned in this standard. Users of this standard are expressly advised that determination of the validity of any such patent rights, and the risk of infringement of such rights, are entirely their own responsibility.*

*This standard is subject to revision at any time by the responsible technical committee and must be reviewed every five years and if not revised, either reapproved or withdrawn. Your comments are invited either for revision of this standard or for additional standards and should be addressed to ASTM International Headquarters. Your comments will receive careful consideration at a meeting of the responsible technical committee, which you may attend. If you feel that your comments have not received a fair hearing you should make your views known to the ASTM Committee on Standards, at the address shown below.*

*This standard is copyrighted by ASTM International, 100 Barr Harbor Drive, PO Box C700, West Conshohocken, PA 19428-2959, United States. Individual reprints (single or multiple copies) of this standard may be obtained by contacting ASTM at the above address or at 610-832-9585 (phone), 610-832-9555 (fax), or service@astm.org (e-mail); or through the ASTM website (www.astm.org).*