



Designation: B 438/B 438M – 95a<sup>ε1</sup>

## Standard Specification for Sintered Bronze Bearings (Oil-Impregnated)<sup>1</sup>

This standard is issued under the fixed designation B 438/B 438M; the number immediately following the designation indicates the year of original adoption or, in the case of revision, the year of last revision. A number in parentheses indicates the year of last reapproval. A superscript epsilon (ε) indicates an editorial change since the last revision or reapproval.

*This standard has been approved for use by agencies of the Department of Defense.*

<sup>ε1</sup> NOTE—B 438 and B 438M were combined editorially with no change in technical requirements in April 1999.

### 1. Scope

1.1 This specification covers sintered bronze, oil-impregnated bearings made primarily from elemental copper, tin, and graphite powders. The manufacturer may, at his discretion, use prealloyed bronze powder in the blend.

1.2 This specification covers the following variables:

1.2.1 *Grades*—Available in three bronze base composition grades identifiable by different graphite contents.

1.2.2 *Type*—Grades 1 and 2 are available in four types described by specific density ranges.

1.3 Bearings ordered to this specification will normally be sized after sintering and will be impregnated with a lubricating oil unless otherwise specified by print.

1.4 The values stated in either inch-pound or SI units are to be regarded separately as standard. Within the text, the SI units are shown in brackets. The values stated in each system are not exact equivalents; therefore, each system shall be used independently of the other. Combining values from the two systems may result in nonconformance with the specification.

### 2. Referenced Documents

2.1 *ASTM Standards:*

B 328 Test Method for Density, Oil Content, and Interconnected Porosity of Sintered Powder Metal Structural Parts and Oil-Impregnated Bearings<sup>2</sup>

E 9 Test Methods of Compression Testing of Metallic Materials at Room Temperature<sup>3</sup>

### 3. Ordering Information

3.1 Orders for parts under this specification shall include the following information:

3.1.1 Dimensions and tolerances (Section 9),

3.1.2 Grade and class (Table 1),

3.1.3 Density specification (Table 2 and Table 3), and

3.1.4 Oil type.

<sup>1</sup> This specification is under the jurisdiction of ASTM Committee B-9 on Metal Powders and Metal Powder Products and is the direct responsibility of Subcommittee B09.04 on Bearings.

Current edition approved Sept. 10, 1995. Published November 1995. Originally published as B 438 – 66 T. Last previous edition B 438 – 95a.

<sup>2</sup> *Annual Book of ASTM Standards*, Vol 02.05.

<sup>3</sup> *Annual Book of ASTM Standards*, Vol 03.01.

**TABLE 1 Chemical Requirements (Composition, %)**

Element	Grade 1	Grade 2	Grade 3
Copper	87.2–90.5	85.7–90.2	83–88.5
Tin	9.5–10.5	9.5–10.5	9.0–10.0
Graphite	0–0.3	0.5–1.8	2.5–5.0
Iron, max	1.0	1.0	1.0
Total other elements by difference, max	1.0	1.0	1.0

### 4. Materials and Manufacture

4.1 Sintered bronze bearings shall be made by molding or briquetting metal powder mixtures to the proper density. The green bearing shall be sintered at a time–temperature relationship to produce a microstructure that is essentially alpha bronze and contains no tin rich phases visible at 300×. Sintered bronze bearings are normally sized after sintering to maintain the dimensional characteristics required of the bearing. After sizing and inspection they are impregnated with a lubricating oil unless otherwise specified.

### 5. Chemical Composition

5.1 The material shall conform to the requirements as to the chemical composition prescribed in Table 1.

### 6. Physical Properties

6.1 *Density*—The density of bearings supplied impregnated with lubricant shall be within the limits prescribed in Table 2 and Table 3, when determined in accordance with Test Method B 328.

**TABLE 2 Density Requirements (Oil-Impregnated)**

	Type	Density g/cm <sup>3</sup>
Grades 1 and 2	1	5.8–6.2 <sup>A</sup>
	2	6.4–6.8
	3	6.8–7.2
	4	7.2–7.6

<sup>A</sup> Maximum density limit of 6.2 g/cm<sup>3</sup> has been established on Type 1 to ensure meeting an oil content of 27 % minimum. Satisfactory bearings can also be produced between Type 1 and Type 2. These bearings have slightly higher strength constants and slightly lower oil content.

**TABLE 3 Density Requirements (Oil-Impregnated)**

	Type	Density, g/cm <sup>3</sup>
Grade 3	1	5.8–6.2
	2	6.2–6.6

6.2 *Oil Content*—Oil content of bearings shall not be less than shown in Table 4 for each grade and type when determined in accordance with Test Method B 328.

**7. Mechanical Properties**

7.1 The manufacturer and purchaser shall agree on a representative number of specimens for tests.

7.2 *Radial Crushing Force*—Radial crushing force shall be determined by compressing the test specimen between two flat steel surfaces at a “no load” speed not greater than 0.2 in./min[5.0 mm/min], the direction of the load being normal to the longitudinal axis of the specimen. The point at which the load drops due to the first crack shall be considered the crushing strength. This test shall be applied to plain cylindrical bearings. Flanged bearings shall be tested by cutting off the flange and compressing the two sections separately. Each section shall meet the minimum strength requirements prescribed in Table 5.

7.2.1 Radial crushing force shall not be less than the value calculated as follows:

$$P = KLT^2/(D-T) \tag{1}$$

where:

- P* = radial crushing force, pounds [N],
- D* = outside diameter of bearing, inches [mm],
- T* = wall thickness of bearing, inches [mm],
- K* = strength constant as shown in Table 5 for grade and type specified, psi [N/mm<sup>2</sup>],
- L* = length of bearing, inches [mm].

7.2.2 Concerning spherical bearings, sample parts from a lot will be machined to a straight wall and radially crushed to calculate the *K* value. Sample parts from the same lot will be radially crushed as is (whole part). By correlation, the minimum radial crush value will be established on the whole bearing and so specified as the minimum radial crush value for the part.

**8. Chemical Analysis**

8.1 If required by purchase agreement, one sample for chemical analysis shall be taken from each lot. A representative sample of chips may be obtained by milling, drilling, filing, or crushing a bearing with clean dry tools without lubrication. In order to obtain oil-free chips, the parts selected for test shall have the oil extracted in accordance with Test Method B 328 if necessary.

8.2 The chemical analysis shall be made in accordance with the methods prescribed in Vol 03.05 of the *Annual Book of ASTM Standards*, or by any other method agreed upon between the manufacturer and the purchaser.

**TABLE 4 Oil Content (Oil Content, Volume %, Min)**

Type	Grade 1	Grade 2	Grade 3
1	27	25	11 <sup>A</sup>
2	19	17	... <sup>B</sup>
3	12	9	...
4	9	7	...

<sup>A</sup> At 3 % graphite, Type 1 will contain 14 % min oil content.

<sup>B</sup> At 3 % graphite, Type 2 will contain 8 % min oil content. At 5 % graphite, Type 2 will contain only a minimal amount of oil.

**TABLE 5 Strength Constant *K* (Strength Constants, Min)<sup>A</sup>, psi [MPa]**

Type	Grade 1	Grade 2	Grade 3
1	15 000 [100]	13 000 [90]	10 000 [70]
2	26 000 [180]	23 000 [160]	15 000 [105]
3	37 000 [255]	30 000 [205]	... [...]
4	40 000 [275]	34 000 [235]	... [...]

<sup>A</sup> For the *K* value specification to be valid, wall thickness must be less than one third of the outside diameter.

**9. Dimensions and Tolerances**

9.1 Permissible variations in dimensions shall be within the limits specified on the drawings describing the bearings accompanying the order or shall be within the limits specified on the order.

**10. Workmanship, Finish, and Appearance**

10.1 Bearings shall be uniform in composition, clean, and conform to applicable drawings.

**11. Sampling**

11.1 *Lot*—Unless otherwise specified, a lot shall consist of parts of the same form and dimensions made from powders of the same composition, formed and sintered under the same conditions, and submitted for inspection at one time.

**12. Inspection**

12.1 Unless otherwise specified, inspection of parts supplied on contract shall be made by the purchaser at the destination.

**13. Rejection**

13.1 Parts that fail to conform to the requirements of this specification may be rejected. Rejection should be reported to the producer or supplier promptly and in writing.

**14. Certification**

14.1 When specified in the purchase order or contract, a producer’s certification shall be furnished to the purchaser that the parts were manufactured, sampled, tested, and inspected in accordance with this specification and have been found to meet the requirements. When specified in the purchase order or contract, a report of the test results shall be furnished.

14.2 The purchase order must specify whether or not the certification includes chemistry.

14.3 Upon request of the purchaser in the contract or order, the certification of an independent third party indicating conformance to the requirements of this specification may be considered.

**15. Supplementary Requirements**

15.1 For some materials, supplementary requirements may be specified. Usually these apply only when specified by the purchaser in the inquiry, contract, or order. These supplementary requirements shall appear separately.

15.2 *Special U.S. Government Requirements*—Requirements that are special to government needs, such as those on responsibility for inspection and purchasing, may be included in the Supplementary Requirements section.

**16. Keywords**

16.1 density; *K* strength constant; oil content; oil-impregnated bearings; porosity

**APPENDIX**

**(Nonmandatory Information)**

**X1. EXPLANATORY INFORMATION**

**X1.1 Design Information**

X1.1.1 In calculating permissible loads, the operating conditions, housing conditions and construction should be considered. The maximum static bearing load should not exceed 8500 psi [60 MPa] of projected bearing area (length times inside diameter of bearing) for this material. This figure is 75 % of the value for the compression deformation limit [yield strength, permanent set of 0.001 in. [0.025 mm] for specimens 1 1/8 in. [30 mm] in diameter and 1 in. [25 mm] in length] as determined in accordance with Test Methods E 9.

**X1.2 Permissible Loads**

X1.2.1 Permissible loads for various operating conditions are given in Table X1.1.

**X1.3 Dimensional Tolerances**

X1.3.1 Commercial dimensional tolerances are included in Table X1.2. Closer tolerances can be held with special tooling or processing, or both.

X1.3.2 The commercial tolerances listed in Table X1.2 are intended for bearings with a 4 to 1 maximum length to inside diameter ratio and a 24 to 1 maximum length to wall thickness ratio.

X1.3.3 Fig. X1.1, Fig. X1.2, and Fig. X1.3 illustrate stan-

**TABLE X1.1 Permissible Loads**

Shaft Velocity, ft/min [m/s]	Permissible Loads, psi [MPa]			
	Grades 1, 2, and 3			
	Type I	Type II	Type III	Type IV
Slow and intermittent	3200 [22]	4000 [28]	4000 [28]	4000 [28]
25 [0.125]	2000 [14]	2000 [14]	2000 [14]	2000 [14]
50 to 100 [0.25–0.50], incl	500 [3.4]	500 [3.4]	550 [3.9]	550 [3.9]
Over 100 to 150 [0.50–0.75], incl	365 [2.2]	325 [2.2]	365 [2.5]	365 [2.5]
Over 150 to 200 [0.75–1.00], incl	280 [1.7]	250 [1.7]	280 [1.9]	280 [1.9]
Over 200 [1.00]	A	A	A	A

<sup>A</sup> For shaft velocities over 200 ft/min [1.00 m/s] the permissible loads may be calculated as follows:

$$P = 50\,000/V[1.75/V] \quad (1)$$

where:

- P* = safe load, psi [MPa] of projected area, and
- V* = shaft velocity, ft/min [m/s]

NOTE 1—With a shaft velocity of less than 50 ft/min [0.25 m/s] and a permissible load greater than 1000 psi [0.15 MPa] an extreme pressure lubricant should be used.

NOTE 2—With good heat dissipation and heat removal techniques, higher PV ratings can be obtained.

**TABLE X1.2 Commercial Dimensional Tolerances**

Inside Diameter, <i>d</i> , and Outside Diameter, <i>D</i> in. [mm]		Total Diameter Tolerances, in. [mm]		
Over	Through			
...	1 [25]	0.001 [0.025]		
1 [25]	1.5 [40]	0.0015 [0.04]		
1.5 [40]	2 [50]	0.002 [0.05]		
2 [50]	2.5 [65]	0.0025 [0.064]		
2.5 [65]	3 [75]	0.003 [0.076]		
Length Tolerances, <i>L</i> , in. [mm]				
Over	Through	±		
...	1.5 [40]	0.005 [0.13]		
1.5 [40]	3 [75]	0.010 [0.25]		
3 [75]	4.5 [115]	0.015 [0.38]		
Outside Diameter, <i>D</i> , in. [mm]	Length, <i>L</i> , in. [mm]		Concentricity, ±in. [mm]	
Over	Through	Over	Through	
...	1 [25]	0 [0]	0 [25]	0.003 [0.08]
...	1 [25]	1 [25]	1.5 [40]	0.004 [0.1]
...	1 [25]	1.5 [40]	2 [50]	0.004 [0.1]
...	1 [25]	2 [50]	2.5 [65]	0.005 [0.13]
...	1 [25]	2.5 [65]	3 [75]	0.005 [0.13]
1 [25]	2 [50]	0 [0]	1 [25]	0.004 [0.1]
1 [25]	2 [50]	1 [25]	1.5 [40]	0.005 [0.13]
1 [25]	2 [50]	1.5 [40]	2 [50]	0.005 [0.13]
1 [25]	2 [50]	2 [50]	2.5 [65]	0.006 [0.15]
1 [25]	2 [50]	2.5 [65]	3 [75]	0.006 [0.15]
2 [50]	3 [75]	0 [0]	1 [25]	0.005 [0.13]
2 [50]	3 [75]	1 [25]	1.5 [40]	0.006 [0.15]
2 [50]	3 [75]	1.5 [40]	2 [50]	0.006 [0.15]
2 [50]	3 [75]	2 [50]	2.5 [65]	0.007 [0.18]
2 [50]	3 [75]	2.5 [65]	3 [75]	0.007 [0.18]
Chamfer Tolerances				
Wall Thickness ( <i>D-d</i> ) <sup>1/2</sup>		Chamfer, <i>C</i> , max, in. [mm]		
in. Over	Through			
...	0.040 [1]	0.008 [0.2]		
0.040 [1]	0.080 [2]	0.012 [0.3]		
0.080 [2]	0.120 [3]	0.016 [0.4]		
0.120 [3]	0.160 [4]	0.025 [0.6]		
0.160 [4]	0.200 [5]	0.030 [0.8]		
0.200 [5]	...	0.030 [0.8]		
Angularity		Tolerance, ±		
40°		5°		
(from the face)				

dard sleeve, standard flange bearings, and standard thrust bearings, respectively. Their dimensions are referenced throughout the tolerance tables. Standard chamfer tolerances are also listed in Table X1.2.

**X1.4 Press Fits**

X1.4.1 Plain cylindrical journal bearings are commonly

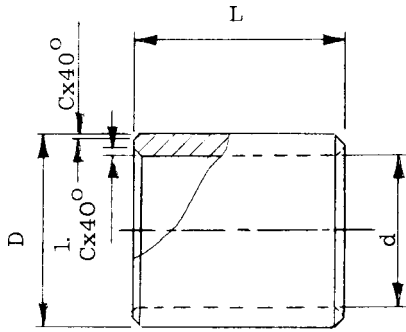

FIG. X1.1 Standard Sleeve Bearing

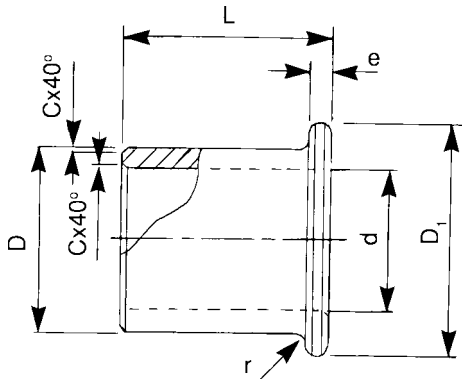

FIG. X1.2 Standard Flange Bearing

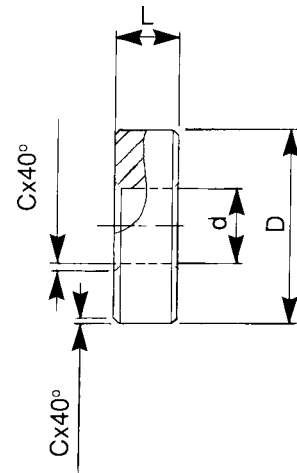

FIG. X1.3 Standard Thrust Bearing

TABLE X1.3 Recommended Press Fits

Outside Diameter of Bearing, in. [mm]		Press Fit	
Over	Through	min, in. [mm]	max, in. [mm]
0.000 [0.000]	0.760 [20]	0.001 [0.025]	0.003 [0.08]
0.760 [20]	1.510 [40]	0.0015 [0.04]	0.004 [0.10]
1.510 [40]	2.510 [63]	0.002 [0.05]	0.005 [0.15]
2.510 [63]	3.010 [75]	0.002 [0.05]	0.006 [0.18]
3.010 [75]	...	0.002 [0.05]	0.007 [0.18]

installed by press fitting the bearing into a housing with an insertion arbor. For housings rigid enough to withstand the press fit without appreciable distortion and for bearings with wall thickness approximately one eighth of the bearing outside diameter, the press fits shown in Table X1.3 are recommended.

### X1.5 Running Clearance

X1.5.1 Proper running clearance for sintered bearings depends to a great extent on the particular application. Therefore, only minimum recommended clearances are listed in Table X1.4. The maximum running clearances will automatically be held within good design practice for average conditions. It is assumed that ground steel shafting having a recommended finish of 4 to 16 root mean square (rms) will be used and all bearings will be oil-impregnated.

### X1.6 Flange and Thrust Bearing Specifications

X1.6.1 Diameter and thickness specifications for flange and thrust washers are shown in Table X1.5.

### X1.7 Lubricating Oil-Impregnated

X1.7.1 It was found that the high grade turbine oil containing rust and oxidation inhibitors and antifoam additives is the most desirable type of oil to be used. The viscosity should be specified by the user in accordance with the application.

**TABLE X1.4 Running Clearances**

Shaft Size, in. [mm]		Clearance, min, in. [mm]
Over	Through	
0.000 [0.000]	0.250 [6]	0.0003 [0.008]
0.250 [6]	0.760 [20]	0.0005 [0.013]
0.760 [20]	1.510 [40]	0.0010 [0.025]
1.510 [40]	2.510 [60]	0.0015 [0.040]
2.510 [60]	... [...]	0.0020 [0.050]

**TABLE X1.5 Flange and Thrust Bearings Diameter and Thickness Tolerances<sup>A</sup>**

Flange Bearings, Flange Diameter Tolerances			
Diameter Range, in. [mm]		Standard	Special
Over	Through	(Tolerance), in. [mm]	(Tolerance), in. [mm]
0 [0]	1½ [40]	±0.005 [±0.13]	± 0.0025 [±0.06]
1½ [40]	3 [75]	±0.010 [±0.25]	± 0.005 [±0.13]
3 [75]	6 [150]	± 0.025 [±0.63]	± 0.010 [±0.25]
Flange Bearings, Flange Thickness Tolerances			
Diameter Range, in. [mm]		Standard	Special
Over	Through	(Tolerance), in. [mm]	(Tolerance), in. [mm]
0 [0]	1½ [40]	±0.005 [±0.13]	± 0.0025 [±0.06]
1½ [40]	3 [75]	±0.010 [±0.25]	± 0.007 [±0.20]
3 [75]	6 [150]	± 0.015 [±0.40]	± 0.010 [±0.25]
Flange Bearings, Radius, <i>r</i> , Tolerance			
Outside Diameter, <i>D</i> , in. [mm]		Radius, <i>r</i> , max, in. [mm]	
Over	Through		
0 [0]	0.475 [12]	0.012 [0.3]	
0.475 [12]	1.200 [30]	0.024 [0.6]	
1.20 [30]	... [...]	0.031 [0.8]	
Thrust Bearings (¼ in. [6.35 mm] Thickness, max), Thickness Tolerances for All Diameters <sup>B</sup>			
Standard (Tolerance), in. [mm]		Special (Tolerance), in. [mm]	
± 0.005 [± 0.13]		±0.0025 [±0.06]	
Parallelism of Faces, max			
Diameter Range, in. [mm]		Standard	Special
Over	Through	(Tolerance), in. [mm]	(Tolerance), in. [mm]
0 [0]	1½ [40]	0.003 [0.08]	0.002 [0.05]
1½ [40]	3 [75]	0.004 [0.10]	0.003 [0.08]
3 [75]	6 [150]	0.005 [0.13]	0.004 [0.10]

<sup>A</sup> Standard and special tolerances are specified for diameters, thickness, and parallelism. Special tolerances should not be specified unless required since they require additional or secondary operations and, therefore, are costlier.

<sup>B</sup> Outside diameter tolerances are the same as for flange bearings.

*The American Society for Testing and Materials takes no position respecting the validity of any patent rights asserted in connection with any item mentioned in this standard. Users of this standard are expressly advised that determination of the validity of any such patent rights, and the risk of infringement of such rights, are entirely their own responsibility.*

*This standard is subject to revision at any time by the responsible technical committee and must be reviewed every five years and if not revised, either reapproved or withdrawn. Your comments are invited either for revision of this standard or for additional standards and should be addressed to ASTM Headquarters. Your comments will receive careful consideration at a meeting of the responsible technical committee, which you may attend. If you feel that your comments have not received a fair hearing you should make your views known to the ASTM Committee on Standards, at the address shown below.*

*This standard is copyrighted by ASTM, 100 Barr Harbor Drive, PO Box C700, West Conshohocken, PA 19428-2959, United States. Individual reprints (single or multiple copies) of this standard may be obtained by contacting ASTM at the above address or at 610-832-9585 (phone), 610-832-9555 (fax), or service@astm.org (e-mail); or through the ASTM website (www.astm.org).*