



Designation: B 771 – 87 (Reapproved 1997)

AMERICAN SOCIETY FOR TESTING AND MATERIALS
100 Barr Harbor Dr., West Conshohocken, PA 19428
Reprinted from the Annual Book of ASTM Standards. Copyright ASTM

Standard Test Method for Short Rod Fracture Toughness of Cemented Carbides¹

This standard is issued under the fixed designation B 771; the number immediately following the designation indicates the year of original adoption or, in the case of revision, the year of last revision. A number in parentheses indicates the year of last reapproval. A superscript epsilon (ϵ) indicates an editorial change since the last revision or reapproval.

1. Scope

1.1 This test method covers the determination of the fracture toughness of cemented carbides (K_{ICSR}) by testing slotted short rod or short bar specimens.

1.2 Values stated in SI units are to be regarded as the standard. Inch-pound units are provided for information only.

1.3 *This standard does not purport to address all of the safety concerns, if any, associated with its use. It is the responsibility of the user of this standard to establish appropriate safety and health practices and determine the applicability of regulatory limitations prior to use.*

2. Referenced Documents

2.1 ASTM Standards:

E 399 Test Method for Plane-Strain Fracture Toughness of Metallic Materials²

E 616 Terminology Relating to Fracture Testing²

3. Terminology Definitions

3.1 *stress intensity factor, K_I , (dimensional units $FL^{-3/2}$)*—the magnitude of the ideal-crack-tip stress field for mode I in a linear-elastic body.

NOTE 1—Values of K for mode I are given by:

$$K_I = \lim_{r \rightarrow 0} [\sigma_y \sqrt{2\pi r}] \quad (1)$$

where:

r = distance directly forward from the crack tip to a location where the significant stress σ_y is calculated, and

σ_y = principal stress normal to the crack plane.

3.2 fracture toughness of cemented carbide, K_{ICSR} , (dimensional units $FL^{-3/2}$)—the material-toughness property measured in terms of the stress-intensity factor K_I by the operational procedure specified in this test method.

4. Summary of Test Method

4.1 This test method involves the application of an opening load to the mouth of the short rod or short bar specimen which contains a chevron-shaped slot. Load versus displacement

across the slot at the specimen mouth is recorded autographically. As the load is increased, a crack initiates at the point of the chevron slot and slowly advances longitudinally, tending to split the specimen in half. The load goes through a smooth maximum when the width of the crack front is about one third of the specimen diameter (short rod) or breadth (short bar). Thereafter, the load decreases with further crack growth. Two unloading-reloading cycles are performed during the test to measure the effects of any macroscopic residual stresses in the specimen. The fracture toughness is calculated from the maximum load in the test and a residual stress parameter which is evaluated from the unloading-reloading cycles on the test record.

5. Significance and Use

5.1 The property K_{ICSR} determined by this test method is believed to characterize the resistance of a cemented carbide to fracture in a neutral environment in the presence of a sharp crack under severe tensile constraint, such that the state of stress near the crack front approaches tri-tensile plane strain, and the crack-tip plastic region is small compared with the crack size and specimen dimensions in the constraint direction. A K_{ICSR} value is believed to represent a lower limiting value of fracture toughness. This value may be used to estimate the relation between failure stress and defect size when the conditions of high constraint described above would be expected. Background information concerning the basis for development of this test method in terms of linear elastic fracture mechanics may be found in Refs (1-4).³

5.2 This test method can serve the following purposes:

5.2.1 To establish, in quantitative terms significant to service performance, the effects of fabrication variables on the fracture toughness of new or existing materials, and

5.2.2 To establish the suitability of a material for a specific application for which the stress conditions are prescribed and for which maximum flaw sizes can be established with confidence.

6. Specimen Configuration, Dimensions, and Preparation

6.1 Both the round short rod specimen and the rectangular shaped short bar specimen are equally acceptable and have been found to have the same calibration (5). The short rod dimensions are given in Fig. 1; the short bar in Fig. 2.

³ The boldface numbers in parentheses refer to the list of references at the end of this standard.

¹ This test method is under the jurisdiction of ASTM Committee B-9 on Metal Powders and Metal Powder Products and is the direct responsibility of Subcommittee B09.06 on Cemented Carbides.

Current edition approved Aug. 28, 1987. Published October 1987.

² Annual Book of ASTM Standards, Vol 03.01.

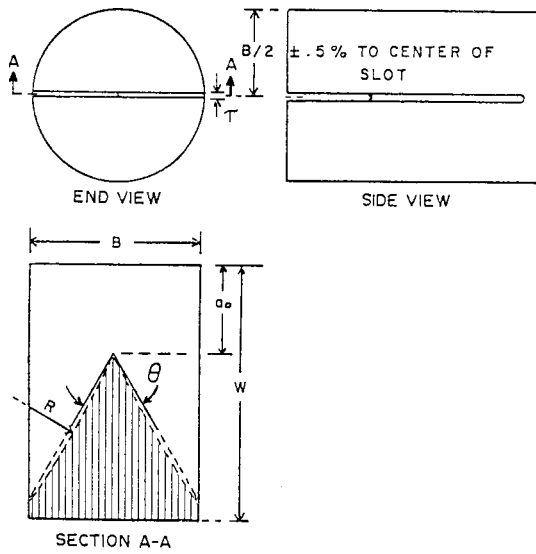

Standard Dimensions
Short Rod

(mm)	(in.)
$B = 12.700 \pm 0.025$	0.500 ± 0.001
$W = 19.050 \pm 0.075$	0.750 ± 0.003
$\tau = 0.381 \pm 0.025$	0.015 ± 0.001
For Curved Slot Option	
$a_o = 6.350 \pm 0.075$	0.250 ± 0.003
$\theta = 58.0^\circ \pm 0.5^\circ$	
$R = 62.23 \pm 1.27$	02.45 ± 0.05
For Straight Slot Option	
$a_o = 6.744 \pm 0.075$	0.266 ± 0.003
$\theta = 55.2^\circ \pm 0.5^\circ$	
$R = \infty$	∞

FIG. 1 Short Rod Specimen

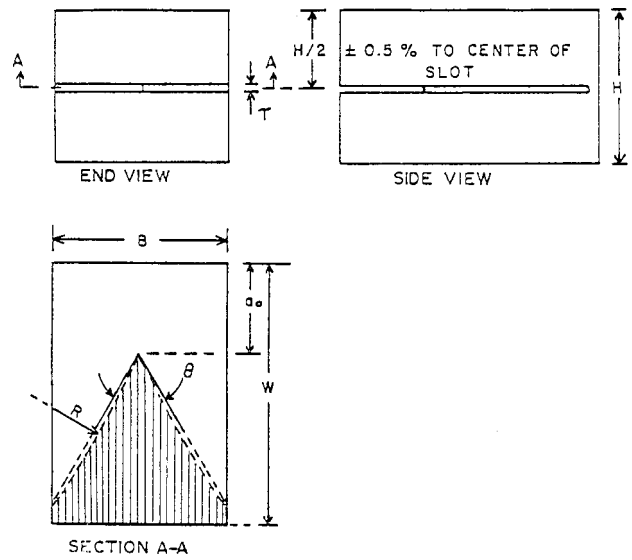

Standard Dimensions
Short Bar

(mm)	(in.)
$B = 12.700 \pm 0.025$	0.500 ± 0.001
$H = 11.050 \pm 0.025$	0.435 ± 0.001
$W = 19.050 \pm 0.075$	0.750 ± 0.003
$\tau = 0.381 \pm 0.025$	0.015 ± 0.001
For Curved Slot Option	
$a_o = 6.350 \pm 0.075$	0.250 ± 0.003
$\theta = 58.0^\circ \pm 0.5^\circ$	
$R = 62.23 \pm 1.27$	2.45 ± 0.05
For Straight Slot Option	
$a_o = 6.744 \pm 0.075$	0.266 ± 0.003
$\theta = 55.2^\circ \pm 0.5^\circ$	
$R = \infty$	∞

FIG. 2 Short Bar Specimen

6.2 *Grip Slot*—Depending on the apparatus used to test the specimen, a grip slot may be required in the specimen front face, as shown in Fig. 3. The surfaces in the grip slot shall have a smooth ground finish so that the contact with each grip will be along an essentially continuous line along the entire grip slot, rather than at a few isolated points or along a short segment within the grip slot.

6.3 *Crack-Guiding Slots*—These may be ground using a diamond abrasive wheel of approximately 124 ± 3 mm (4.9 ± 0.1 in.) diameter, with a thickness of 0.36 ± 0.01 mm (0.0140 ± 0.0005 in.). The resulting slots in the specimen are slightly thicker than the diamond wheel (0.38 ± 0.02 mm, or 0.015 ± 0.001 in.). A diamond concentration number of 50, and a grit size of 150 are suggested. Dimensions are given in Fig. 1 and Fig. 2 for two slotting options: (1) Specimens with curved slot bottoms made by plunge feeding the specimen onto a diamond cutting wheel of a given radius, and (2) Specimens with straight slot bottoms made by moving the specimen by a cutting wheel. The values of a_o and θ for the two slot configurations are chosen to cause the specimen calibration to remain constant.

7. Apparatus

7.1 The procedure involves testing of chevron-slotted specimens and recording the load versus specimen mouth opening displacement during the test.

7.2 *Grips and Fixtures for Tensile Test Machine Loading*—Grip slots are required in the specimen face for this test

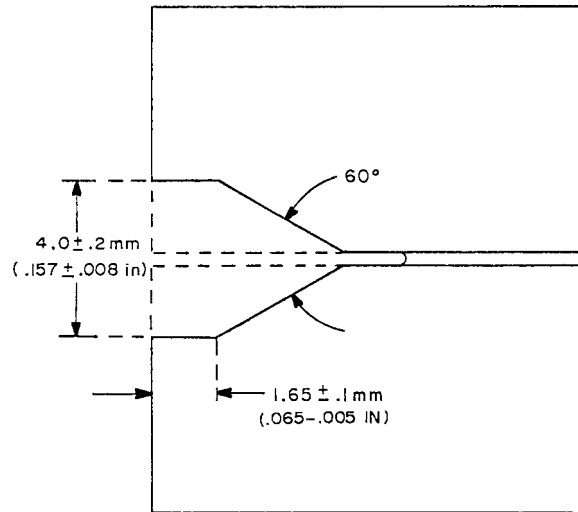

NOTE 1—The dashed lines show the front face profile of Figs. 1 and 2 without grip slot.

FIG. 3 Short Rod and Short Bar Grip Slot in Specimen Front Face

method, as shown in Fig. 3. Fig. 4 shows the grip design. Grips shall have a hardness of 45 HRC or greater, and shall be capable of providing loads to at least 1560 N (350 lbf). The grips are attached to the arms of tensile test machine by the pin and clevis arrangement shown in Fig. 5. The grip lips are

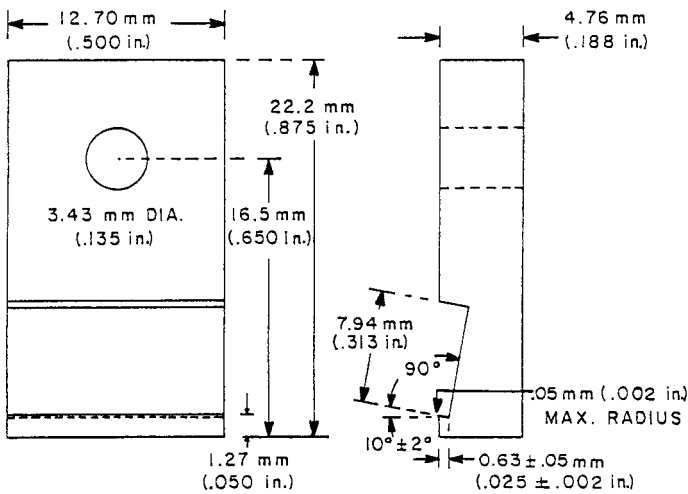

FIG. 4 Grip Design

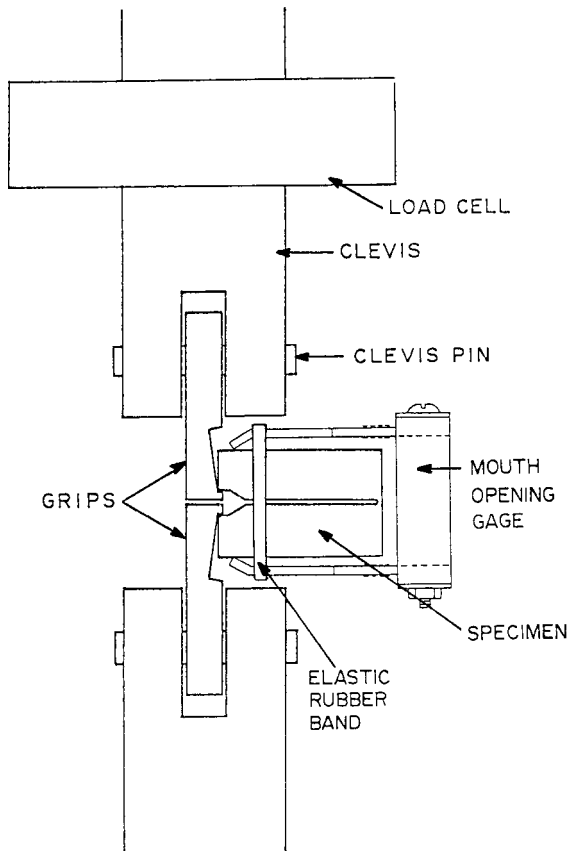

FIG. 5 Tensile Test Machine Test Configuration

inserted into the grip slot in the specimen, and the specimen is loaded as the test machine arms apply a tensile load to the grips. A transducer for measuring the specimen mouth opening displacement during the test, and means for automatically recording the load-displacement test record, such as an X-Y recorder, are also required when using the tensile test machine apparatus. A suggested design for the specimen mouth opening displacement gage appears in Fig. 6. The gage shall have a displacement resolution of 0.25 μm (10×10^{-6} in.) or better. However, it is not necessary to calibrate the displacement axis

of the test record since only displacement ratios are used in the data analysis.

7.3 *Distributed Load Test Machine*⁴—An alternative special purpose machine that has been found suitable for the test requires no grip slot in the front face of the specimen. A thin stainless steel inflatable bladder is inserted into the chevron slot in the mouth of the specimen. Subsequent inflation of the bladder causes it to press against the inner surfaces of the slot, thus producing the desired loading. The machine provides load and displacement outputs, which must be recorded externally on a device such as an X-Y recorder.

7.4 *Testing Machine Characteristics*—It has been observed that some grades of carbides show a “pop-in” type of behavior in which the load required to initiate the crack at the point of the chevron slot is larger than the load required to advance the crack just after initiation, such that the crack suddenly and audibly jumps ahead at the time of its initiation. Occasionally, the load at crack initiation can exceed the load maximum which occurs as the crack passes through the critical location in the specimen. When this occurs, a very stiff machine with controlled displacement loading is necessary in order to allow the crack to arrest well before passing beyond the critical location. The large pop-in load is then ignored, and the subsequent load maximum as the crack passes through the critical location is used to determine K_{IcSR} . Stiff machine loading is also required in order to maintain crack growth stability to well beyond the peak load in the test, where the second unloading-reloading cycle is initiated.

8. Procedure

8.1 *Number of Tests*—A minimum of 3 replicate tests shall be made.

8.2 Specimen Measurement:

8.2.1 Measure and record all specimen dimensions. If the dimensions are within the tolerances shown in Fig. 1 and Fig. 2, no correction to the data need be made for out-of-tolerance dimensions. If one or more of the parameters a_o , W , θ or τ are out of tolerance by up to 3 times the tolerances shown in Fig. 1 and Fig. 2, valid tests may still be made by the application of the appropriate factors to account for the deviation from standard dimensions (see 9.3). If the slot centering is outside the indicated tolerance, the crack is less likely to follow the chevron slots. However, the test may still be considered successful if the crack follows the slots sufficiently well, as discussed in 9.2.

8.2.2 The slot thickness measurement is critical on specimens to be tested on a Fractometer. It should be measured to within 0.013 mm (0.0005 in.) at the outside corners of the slot using a feeler gage. If a feeler gage blade enters the slot to a depth of 1 mm or more, the slot is said to be at least as thick as the blade. Because the saw cuts forming the chevron slot overlap somewhat in the mouth of the specimen, and because the cuts may not meet perfectly, the slot width near the center of the mouth may be larger than the width at the outside corners. If the slot width near the center exceeds the slot width

⁴ Fractometer, a trademark of Terra Tek Systems, 360 Wakara Way, Salt Lake City, UT 84108, has been found satisfactory for this purpose.

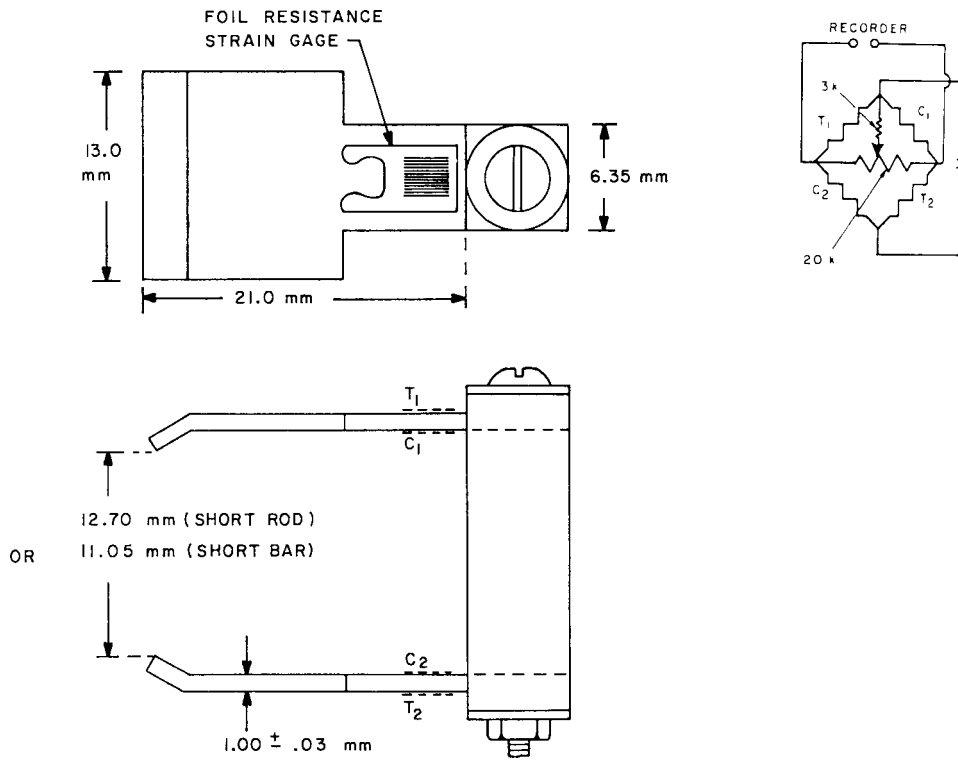

FIG. 6 Suggested Design for a Specimen Mouth Opening Gage

at the corners by more than 0.10 mm (0.004 in.), a test of that specimen by a Fractometer is invalid.

8.3 Specimen Testing Procedure:

8.3.1 Load Transducer Calibration:

8.3.1.1 Calibrate the output of the load cell in the test machine to assure that the load cell output, as recorded on the load versus displacement recorder, is accurately translatable into the actual force applied to the specimen. In those cases in which a distributed load test machine is used (see 7.3), the calibration shall be performed according to the instructions in Annex A1.

8.3.1.2 Install the specimen on the test machine. If using the tensile test machine (see 7.2), operate the test machine in the “displacement control” mode. Bring the grips sufficiently close together such that they simultaneously fit into the grip slot in the specimen face. Then increase the spacing between the grips very carefully until an opening load of 10 to 30 N (2 to 7 lb) is applied to the specimen. Check the alignment of the specimen with respect to the grips, and the alignment of the grips with respect to each other. The grips shall be centered in the specimen grip slot to within 0.25 mm (0.010 in.). The vertical offset between the grips shall not exceed 0.13 mm (0.005 in.). Using a magnifying glass, observe the grips in the grip slot from each side of the specimen to assure that the specimen is properly installed. The grips should extend as far as possible into the grip slot, resulting in contact lines (load lines) at 0.63 mm (0.025 in.) from the specimen front face. Correct any deviations from the desired specimen alignment.

8.3.1.3 Install the specimen mouth opening displacement gage on the specimen. The gage must sense the mouth opening no farther than 1 mm (0.040 in.) from the front face of the specimen. If the gage design of Fig. 6 is used, the contact force

between the gage arms and the specimen can be adjusted with a rubber elastic band so the gage will support itself, as indicated in Fig. 5. However, the contact force must not be more than 2 N (0.5 lb), as it increases the measured load to fracture the specimen.

8.3.1.4 Adjust the displacement (*x*-axis) sensitivity of the load-displacement recorder to produce a convenient-size data trace. A 70° angle between the *x*-axis and the initial elastic loading trace of the test is suggested. A quantitative calibration of the displacement axis is not necessary.

8.3.1.5 With the load-displacement recorder operating, test the specimen by causing the specimen mouth to open at a rate of 0.0025 to 0.0125 mm/s (0.0001 to 0.0005 in./s). The specimen is unloaded by reversing the motion of the grips twice during the test. The first unloading is begun when the slope of the unloading line on the load-displacement record will be approximately 70 % of the initial elastic loading slope. (For estimating the point at which the unloadings should be initiated, it can be assumed that the unloading paths will be linear and will point toward the origin of the load-displacement record.) The second unloading is begun when the unloading slope will be approximately 35 % of the initial elastic loading slope. Each unloading shall be continued until the load on the specimen has decreased to less than 10 % of the load at the initiation of the unloading. The specimen shall be immediately reloaded and the test continued after each unloading. The test record generated by the above procedure should be similar to that of Fig. 7.

8.3.2 Crack-Pop-In—If a sudden load drop occurs simultaneously with an audible “pop” or “tick” sound from the specimen during the initial part of the test when the load is rising most rapidly, a crack pop-in has occurred at the point of

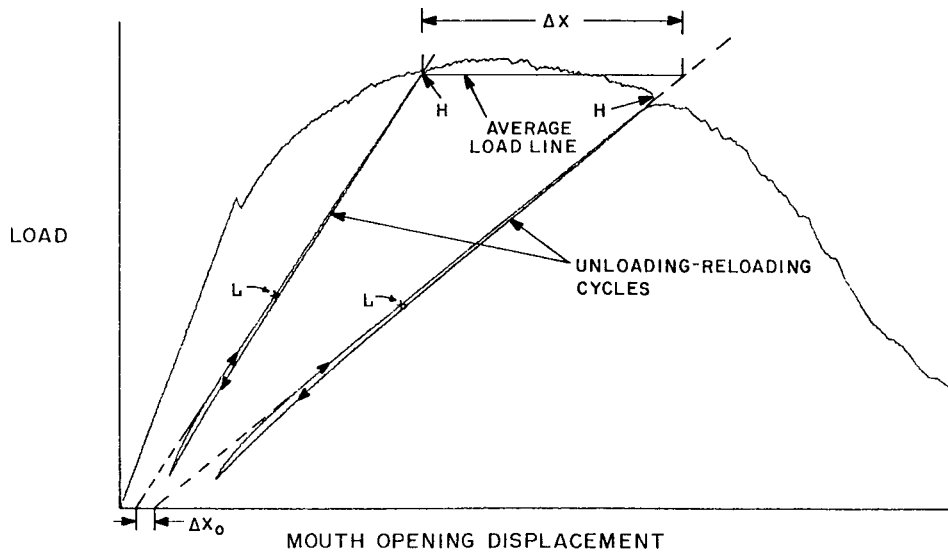

FIG. 7 Sample Load-Displacement Test Record with Data Analysis Constructions and Definitions

the chevron slot. If the pop-in is large, such that the first unloading slope that can be drawn is less than half of the initial elastic loading slope, the test is invalid.

9. Calculation and Interpretation of Results

9.1 Remove the specimen from the apparatus. If the two halves are still joined, break them apart with a wedge. Examine the fracture surfaces for any imperfections that may have influenced the measured peak load. Any imperfections (such as a void, a surface irregularity, or a piece of foreign matter) that is visible to the naked eye may influence the measurement if the imperfection is located between 7.6 mm (0.30 in.) and 14.2 mm (0.56 in.) from the mouth of the specimen. Imperfections outside this region do not affect the peak load unless they are very large. Discard the data whenever the peak load may have been affected by an imperfection in the fracture plane.

9.2 Examine the fracture surface to determine how well the crack followed the chevron slots in splitting the specimen apart. If the “crack follow” was imperfect, the crack will have cut substantially farther into one half of the specimen than the other, and the crack surface will not intersect the bottom of the chevron slots, as shown in Fig. 8. The size of the lip overhanging the slot bottom determines whether the crack follow was sufficiently good for a valid test. Measure the “overhang” of the fracture surface over the slot bottom on each side of the chevron at a distance of 10.8 mm (0.425 in.) from the mouth of the specimen (Fig. 8). If the sum, Δb , of the overhangs on each side of the chevron exceeds 0.25 mm (0.010 in.), the test is invalid.

NOTE 2—Imperfect crack follow often results from poor centering of the chevron slot in the specimen. However, it can also result from strong residual stresses in the test specimen.

9.3 *Out-of-Tolerance Dimension Corrections*—If the specimen dimensions are all within the tolerances specified in Fig. 1 and Fig. 2, assign $C_c = 1$, where C_c is the specimen configuration correction factor. If a_o , W , θ , or τ differ from their specified tolerance by more than 3 times the tolerance specified in Fig. 1 or Fig. 2, the sample is invalid. If a_o , W , θ , or τ differ

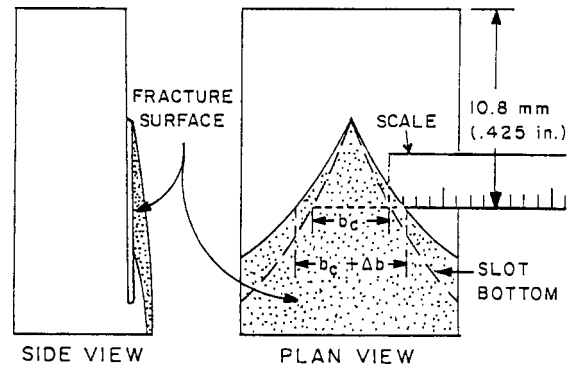

NOTE 1—For a valid test, the overhang sum Δb , measured at a distance of 10.8 mm from the specimen mouth, must not exceed 0.25 mm (0.010 in.).

FIG. 8 Short Rod or Short Bar Tested Specimen Half with Imperfect Crack Guidance by the Slots

from their specified tolerance by less than or equal to three times the tolerance specified in Fig. 1 or Fig. 2, compensation can be made using the correction factors defined in 9.3.1 through 9.3.5 (7). The subscript *nom* refers to the nominal dimension specified in Fig. 1 or Fig. 2.

9.3.1 If a_o is within tolerance, assign $C_a = 1$. However, if a_o is out of tolerance, calculate:

$$C_a = 1 + 1.8(a_o - a_{nom})/B. \quad (2)$$

9.3.2 If W is within tolerance, assign $C_W = 1$. However, if W is out of tolerance, calculate:

$$C_W = 1 - 0.7(W - W_{nom})/B. \quad (3)$$

9.3.3 If θ is within tolerance, assign $C_\theta = 1$. However, if θ is out of tolerance, calculate:

$$C_\theta = 1 - 0.015(\theta - \theta_{nom}) \quad (4)$$

where θ is in degrees.

9.3.4 If τ is within tolerance, or if τ is out of tolerance and grip loading was used, assign $C_\tau = 1$. However, if τ is out of tolerance and distributed loading (Fractometer) was used, calculate:

$$C_\tau = 1 - 12.5(\tau - \tau_{nom})/B \quad (5)$$

9.3.5 Calculate C_c from:

$$C_c = C_a C_w C_\theta C_\tau \quad (6)$$

9.4 Analyze the test record to obtain p , the residual stress parameter. The basis for the use of p to compensate for the effects of any macroscopic longitudinal residual stresses in the specimen is given in Ref (3).

9.4.1 Locate the “high” and “low” points on each unloading-reloading cycle. A high point is the point at which the mouth opening displacement started decreasing to unload the specimen, and the corresponding low point is on the reloading part of the unloading-reloading cycle at half the load of the high point. The high and low points are labeled H and L, respectively, in Fig. 7.

9.4.2 Draw the ideal elastic release path approximations through the high and low points of each unloading-reloading cycle (slanted dashed lines of Fig. 7).

9.4.3 Draw the horizontal “average load” line between the two ideal elastic release lines (Fig. 7). The average load line is drawn at the level of the average load on the data trace between the two unloading-reloading cycles. It must be drawn horizontal, but the choice of the average load can vary by $\pm 5\%$ from the correct value without materially affecting the results.

9.4.4 Measure ΔX (the distance between the ideal elastic release lines at the average load line) and ΔX_o (the distance between the ideal elastic release lines at the zero load line). Calculate $p = \Delta X_o / \Delta X$. If the release lines cross before reaching the zero load axis, ΔX_o , and therefore p , are considered to be negative. The analysis is nevertheless valid. However, the test is considered invalid unless $-0.15 < p < +0.15$, inasmuch as the theory assumes relatively small values of p .

9.5 From the test record, measure the maximum load in the experiment, F_c .

9.6 Calculate K_{ICSR} .

9.6.1 If grips and fixtures for tensile test machine loading are used, calculate:

$$K_{QSR} = AF_c C_c (1 + p) / B^{3/2} \quad (7)$$

in which $A = 22.0$ and B is the specimen diameter (short rod) or breadth (short bar) in the system of units in which F_c and K_{QSR} are expressed. A is the dimensionless specimen configuration calibration constant defined in Ref (1) and evaluated in Ref (6). It is not a function of machine stiffness, material properties, nor absolute specimen size, so long as the scaled specimen configuration, including the location of the applied load on the specimen, remains constant. The calibrated value of A is uncertain by about 5%.

9.6.2 If the distributed load test machine is used, calculate:

$$K_{QSR} = C_c (1 + p) K_{DL} \quad (8)$$

where:

K_{DL} = the fracture toughness output of the machine (see Annex A1).

9.6.3 If all of the validity requirements of the test are satisfied, then:

$$K_{ICSR} = K_{QSR} \quad (9)$$

Validity requirements are specified in 6.4, 6.5, 8.2, 8.3.6, 9.1, 9.2, and 9.4.4.

10. Report

10.1 The report shall include the following for each specimen tested:

10.1.1 Specimen identification,

10.1.2 Environment of test, if other than normal atmosphere and room temperature,

10.1.3 Diameter, B (short rod) or Breadth, B (short bar),

10.1.4 Length, W ,

10.1.5 Height, H (short bar only),

10.1.6 Chord angle, θ ,

10.1.7 Slot thickness, τ ,

10.1.8 Crack overhang sum, Δb , in accordance with 9.2,

10.1.9 Comments on any unusual appearance of the fracture surface, and

10.1.10 K_{ICSR} , or K_{QSR} with a summary of the invalidities.

11. Precision and Bias

11.1 Precision is the closeness of agreement between individual test results. The precision of a K_{ICSR} determination is a function of the precision and bias of the various measurements of the specimen and testing fixtures, the precision and bias of the load and displacement measuring and recording devices used to produce the test record, and the precision of the constructions made on the record.

11.2 The precision of K_{ICSR} measurements is estimated based on a round robin test series reported in a research report.⁵ Six laboratories participated in the round robin, in which five different grades of cemented carbides were tested. Each laboratory tested approximately five short rod specimens of each grade of material. The average within-laboratory percent standard deviation (the repeatability) was 2.9%. This pertains to tests done on the same material by the same operator using the same equipment within a short time. The average between-laboratory percent standard deviation (the reproducibility) was 5.0%.

11.3 Bias is a systematic error that contributes to the difference between a population mean of the measurements and an accepted reference or true value. Since there is no accepted method for determining the true fracture toughness of cemented carbides, no statement on bias can be made.

⁵ Supporting data are available from ASTM Headquarters. Request RR: B09-1005.

(Mandatory Information)
A1. CALIBRATION OF THE DISTRIBUTED LOAD TEST MACHINE

A1.1 The equation for the fracture toughness (critical stress intensity factor) for the specimen geometries of this test method and for the loading configuration used by the distributed load (*DL*) test machine is:

$$K_{DL} = 8.26 P_c \sqrt{B}, \quad (\text{A1.1})$$

where:

P_c = the peak pressure in the inflatable bladder during the test.

The factor 8.26 is a dimensionless constant for the specimen configuration and the loading configuration of the distributed load test machine. It is entirely comparable to the dimensionless constant $A = 22.0$ which applies for the grip loading configuration of this test method (see 9.6.1).

A1.2 The machine is normally calibrated to display the signal from the pressure transducer in units of pressure (MPa or ksi) times $8.26 \sqrt{B}$, where $B = 0.0127$ m for the SI read-out, or $B = 0.500$ in. for the inch-pound read-out. Thus, the peak reading displayed in a test is the K_{DL} for the specimen.

A1.3 The machine shall be calibrated in accordance with the manufacturer's instructions before testing each specimen. This involves switching a shunt resistor into the bridge circuit

of the pressure transducer to provide the same bridge balance offset as a known pressure. The amplifier gain is then adjusted to cause the display to read the correct value.

A1.4 The equivalent pressure signal obtained by switching the shunt resistor into the bridge circuit should be checked yearly, or more often by the manufacturer, or as follows:

A1.4.1 Disconnect the pressure tube from the intensifier, zero the display, and connect a pressure tube from a pressure standard to the intensifier.

A1.4.2 Apply an accurately known pressure of about 14 MPa (2 ksi). Adjust the amplifier gain to obtain an output display of $0.931 \text{ MPa} \sqrt{m}$ per MPa of applied pressure (SI), or $5.84 \text{ ksi} \sqrt{\text{in.}}$ per ksi of applied pressure (inch-pound). Check that the display returns to zero for zero applied pressure.

A1.4.3 With zero applied pressure and the display reading zero, switch the calibrating resistor into the bridge circuit and note the display. This displayed reading should be used in subsequent test-to-test calibrations.

NOTE A1.1—In performing the above calibration, considerable care must be exercised to prevent air from entering the machine's pressure system, as air destroys the stiffness of the system.

REFERENCES

- (1) Barker, L. M., "A Simplified Method for Measuring Plane Strain Fracture Toughness", *Engineering Fracture Mechanics*, Vol 9, 1977, pp. 361–369.
- (2) Barker, L. M., "Short Rod K_{Ic} Measurements of Al_2O_3 ", *Fracture Mechanics of Ceramics*, Vol 3, 1978, pp. 483–494.
- (3) Barker, L. M., "Residual Stress Effects on Fracture Toughness Measurements," *Advances in Fracture Research (ICF5)*, (D. Francois, Ed.), Vol 5, 1981, p. 2563.
- (4) "Fracture Toughness Testing and Its Applications," ASTM STP 381, Am. Soc. Testing Mats., April 1965.
- (5) Barker, L. M., "Short Bar Specimens for K_{Ic} Measurements," ASTM STP 678, Am. Soc. Testing Mats., 1979, pp. 73–82.
- (6) Barker, L. M., and Baratta, F. I., "Comparisons of Fracture Toughness Measurements by the Short Rod and ASTM Standard Method of Test for Plane-Strain Fracture Toughness of Metallic Materials (E 399–78)," *Journal of Testing and Evaluation*, Vol 8, 1980, pp. 97–102.
- (7) Barker, L. M., "Compliance Calibration of a Family of Short Rod and Short Bar Fracture Toughness Specimens," *Engineering Fracture Mechanics*, 17, 1983, pp. 289–312.

The American Society for Testing and Materials takes no position respecting the validity of any patent rights asserted in connection with any item mentioned in this standard. Users of this standard are expressly advised that determination of the validity of any such patent rights, and the risk of infringement of such rights, are entirely their own responsibility.

This standard is subject to revision at any time by the responsible technical committee and must be reviewed every five years and if not revised, either reapproved or withdrawn. Your comments are invited either for revision of this standard or for additional standards and should be addressed to ASTM Headquarters. Your comments will receive careful consideration at a meeting of the responsible technical committee, which you may attend. If you feel that your comments have not received a fair hearing you should make your views known to the ASTM Committee on Standards, 100 Barr Harbor Drive, West Conshohocken, PA 19428.