



Designation: B 809 – 95

Standard Test Method for Porosity in Metallic Coatings by Humid Sulfur Vapor ("Flowers-of-Sulfur")¹

This standard is issued under the fixed designation B 809; the number immediately following the designation indicates the year of original adoption or, in the case of revision, the year of last revision. A number in parentheses indicates the year of last reapproval. A superscript epsilon (ϵ) indicates an editorial change since the last revision or reapproval.

1. Scope

1.1 This standard covers equipment and test methods for determining the porosity of metallic coatings, where the pores penetrate down to a silver, copper, or copper-alloy substrate.

1.2 This test method is suitable for coatings consisting of single or combined layers of any coating that does not significantly tarnish in a reduced sulfur atmosphere, such as gold, nickel, tin, tin-lead, and palladium, or their alloys.

1.3 This test method is designed to determine whether the porosity level is less than or greater than some value which by experience is considered by the user to be acceptable for the intended application.

1.4 Recent reviews of porosity testing and testing methods can be found in the literature.^{2,3} Guide B 765 is suitable to assist in the selection of porosity tests for electrodeposits and related metallic coatings. Other porosity test standards are Test Methods B 735, B 741, B 798, and B 799.

1.5 The values stated in SI units are to be regarded as the standard. The values given in parentheses are for information only.

1.6 *This standard does not purport to address all of the safety concerns, if any, associated with its use. It is the responsibility of the user of this standard to establish appropriate safety and health practices and determine the applicability of regulatory limitations prior to use.* For specific hazards statements, see Section 8.

2. Referenced Documents

2.1 ASTM Standards:

B 374 Terminology Relating to Electroplating⁴

B 542 Terminology Relating to Electrical Contacts and Their Use⁵

B 735 Test Method for Porosity in Gold Coatings on Metal Substrates by Nitric Acid Vapor⁵

B 741 Test Method for Porosity in Gold Coatings on Metal Substrates by Paper Electrography⁵

B 765 Guide for Selection of Porosity Tests for Electrodeposits and Related Metallic Coatings⁴

B 798 Test Method for Porosity in Gold or Palladium Coatings on Metal Substrates by Gel-Bulk Electrography⁵

B 799 Test Method for Porosity of Gold and Palladium Coatings by Sulfurous Acid/Sulfur-Dioxide Vapor⁵

3. Terminology

3.1 *Definitions*—Many terms used in this test method are defined in Terminologies B 374 and B 542.

3.2 *Definitions of Terms Specific to This Standard:*

3.2.1 *corrosion products*—reaction products of the basis metal or underplate, that protrude from, or are otherwise attached to, the coating surface after the test exposure.

3.2.2 *measurement area*—*in this test method*, that portion or portions of the surface that is examined for the presence of porosity. The measurement area shall be indicated on the drawings of the parts, or by the provision of suitably marked samples.

3.2.3 *metallic coatings*—*in this test method*, include platings, claddings, or other metallic coatings applied to the substrate. The coating can comprise a single metallic layer or a combination of metallic layers.

3.2.4 *porosity*—the presence of any discontinuity, crack, or hole in the coating that exposes a different underlying metal (see Guide B 765).

3.2.5 *significant surface*—*of a coated part*, is that portion (or portions) of the coating surface that is essential to the serviceability or function of the part, or which can be the source of corrosion products or tarnish films that interfere with the function of the part. For many plated products, the critical surface is identical to the measurement area.

3.2.6 *tarnish*—reaction products of copper or silver with oxygen or reduced sulfur (that is, hydrogen sulfide (H₂S) and elemental sulfur vapor, but not sulfur dioxide (SO₂) or other sulfur oxides). They consist of thin films or spots that do not protrude significantly from the surface of the metallic coating (in contrast to *corrosion products*).

¹ This test method is under the jurisdiction of ASTM Committee B-8 on Metallic and Inorganic Coatings and is the direct responsibility of Subcommittee B08.10 on General Test Methods.

Current edition approved Oct. 10, 1995. Published December 1995. Originally published as B 809 – 90. Last previous edition B 809 – 90.

² Clarke, M., "Porosity and Porosity Tests," *Properties of Electrodeposits*, Sard, Leidheiser, and Ogburn, eds., The Electrochemical Society, 1975, p. 122.

³ Krumbain, S. J., "Porosity Testing of Contact Platings," *Transactions of the Connectors and Interconnection Technology Symposium*, Philadelphia, PA, October 1987, p. 47.

⁴ *Annual Book of ASTM Standards*, Vol 02.05.

⁵ *Annual Book of ASTM Standards*, Vol 03.04.

3.2.7 *tarnish creepage*—movement of tarnish films across the surface of the coating, the tarnish having originated either from pores or cracks in the coating or from areas of bare silver, copper, or copper alloy near the measurement area (as in a cut edge).

3.2.8 *underplate(s)*—a metallic coating layer(s) between the substrate and the topmost layer or layers. The thickness of an underplate is usually greater than 1 μm (40 $\mu\text{in.}$).

4. Summary of Test Method

4.1 The test specimens are suspended over “flowers-of-sulfur” (powdered sulfur) in a vented container at controlled elevated relative humidity and temperature. Elemental sulfur vapor, which always exists in equilibrium with sulfur power in a closed system, attacks any exposed silver, copper, or copper alloy, such as at the bottom of pores. Brown or black tarnish spots indicate porosity.

4.2 Exposure periods may vary, depending on the extent of porosity to be revealed.

4.3 This test involves tarnish or oxidation (corrosion) reactions in which the products delineate defect sites in coatings. Since the chemistry and properties of these products may not resemble those found in natural or service environments, this test is not recommended for prediction of product performance unless correlation is first established with service experience (but see 5.3).

5. Significance and Use

5.1 A major use of this test procedure is for determining coating quality. Porosity tests are indications of the completeness of protection or coverage offered by the coatings, since the coatings described in 1.2 are intended to be protective when properly applied. The porosity test results are therefore a measure of the deposition process control.

5.2 A particular purpose of the humid sulfur vapor test is for determining the quality of underplates of nickel or nickel alloy in those finish systems that have thin, 1.2 μm or less (50 $\mu\text{in.}$ or less) top layers above the nickel, since porosity in the underplate usually continues into such top layers.

5.3 The humid sulfur vapor test is often used as an environmental test to simulate many indoor humid atmosphere tarnishing and tarnish creepage effects. However, the chemistry and properties of these tarnish films may not resemble those found in other service environments. For such product performance evaluations, the test should only be used in combination with other performance evaluation tests, as specified in the referencing document for that product.

5.4 Porosity tests differ from corrosion and aging tests, since the latter are intended to measure the chemical inertness of the coating. In contrast, in a good porosity test procedure the corrosive agent should not attack the coating. It must, instead, clean, depolarize, and/or activate the substrate metal exposed by the pore, and attack it sufficiently to cause reaction products to fill the pore to the surface of the coating.

5.5 The humid sulfur test is highly sensitive, and is capable of detecting virtually all porosity that penetrates down to copper or copper alloys. Since nickel is not attacked by moist sulfur vapor at 100°C or less, this test will not detect pores or

cracks in the top coating if such pores or cracks do not penetrate through the nickel underplate overlaying the copper.

5.6 The level of porosity in the coating that may be tolerable depends on the severity of the environment that the product is likely to encounter during service or storage. Also, the location of the pores on the surface is important. If the pores are few in number or away from the significant surfaces, their presence can often be tolerated.

5.7 The present test method can be used on samples of various geometries, such as curved surfaces. It can also be used for selective area coatings, if allowance is made for tarnish creepage from bare copper alloy areas.

5.8 This test method is destructive in that it reveals the presence of porosity by contaminating the surface with tarnish films. Any parts exposed to this test method should not be placed in service.

5.9 The relationship of porosity levels revealed by this test method to product performance and service life must be made by the user of the test through practical experience or by judgment. Thus, absence of porosity in the coating may be a requirement for some applications, while a few pores on the significant surfaces may be acceptable for others.

6. Apparatus

6.1 *Test Vessel*—May be any convenient-size vessel of glass, acrylic-resin (or of any other material that is not affected by high humidity or sulfur), such as a glass desiccator of 9 to 10 L capacity. It should have a lid or cover capable of being plugged with a stopper. The stopper shall have a 1 to 4 mm diameter hole through it to serve as a vent.

6.2 *Sample Fixture or Holders*—Supports or hangers shall be made from material such as glass or acrylic plastic that will not be affected by sulfur or high humidity, and shall be arranged so that the samples will be at least 75 mm away from the humidity controlling solution or sulfur powder (see 6.3). The samples shall also be at least 25 mm from the vessel walls and at least 10 mm from other samples or other surfaces. Do not use a desiccator plate. The fixture shall not cover more than 20 % of the vessel’s cross-sectional area so that air movement within the vessel will not be restricted during the test.

6.3 *Glass Dish*—Petri or other shallow dish approximately 15 cm in diameter to hold powdered sulfur. Dish may be supported above the constant humidity solution with plastic blocks, or floated on the liquid.

6.4 *Oven, Air-circulating*, capable of maintaining test vessel at a temperature of $50 \pm 2^\circ\text{C}$ ($122 \pm 4^\circ\text{F}$).

6.5 *Temperature and Relative Humidity (RH) Sensor*, with a remote sensor probe having a range of approximately 76 to 95 % RH at 50°C, which can be kept in the desiccator during test.⁶

6.6 *Microscope, Optical, Stereo, 10 ×*—It is preferred that one eyepiece contain a graduated reticle for measuring the diameter of tarnish spots. The reticle shall be calibrated for the magnification at which the microscope is to be used.

6.7 *Light Source*, incandescent or circular fluorescent.

⁶ The Hydrodynamics Hygrometer, manufactured by Newport Scientific, Inc., has been found satisfactory for this purpose.

7. Reagents

7.1 *Potassium Nitrate* (KNO_3)—American Chemical Society analyzed reagent grade, or better.

9.1.3 During equilibration, open desiccator occasionally and stir contents. As the temperature in the vessel approaches 50°C (122°F), as indicated by the temperature probe, adjust oven

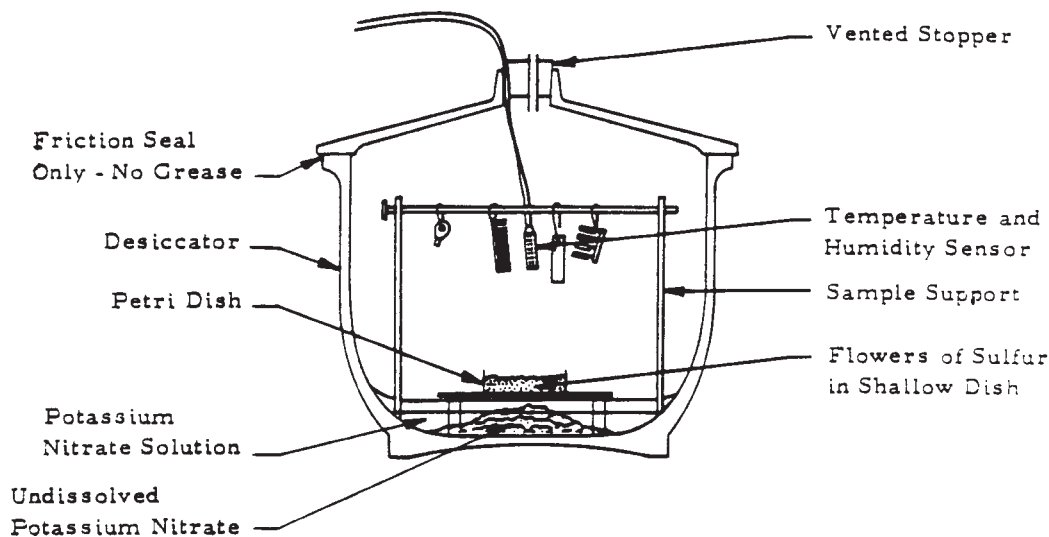

FIG. 1 Typical Test Equipment Setup

7.2 *Sulfur, Sublimed* (“Flowers-of-Sulfur”), N.F. or laboratory grade.⁷

8. Safety and Health Precautions

8.1 All of the normal precautions shall be observed in handling the materials required for this test. This shall also include, but not be limited to, procuring and reviewing material Safety Data Sheets (MSDS) that meet the minimum requirements of the U.S. Occupational Safety and Health Administration (OSHA) Hazard Communication Standard for all chemicals used in cleaning and testing, and observing the recommendations given.

9. Procedure

9.1 *Equilibration of Test Vessel*—For the initial series of tests, the test vessel shall be prepared for equilibration at least a day before the first exposure.

NOTE 1—For all subsequent tests, the initial 24-h equilibration procedures do not have to be repeated (see Note 2 and 9.8).

9.1.1 Place the test vessel in the oven, with sample supports in place. Make a saturated solution of potassium nitrate, prepared by adding approximately 200 g of the salt to approximately 200 mL of deionized water, with stirring, and place it in the bottom of the vessel.

NOTE 2—The saturated solution will contain undissolved potassium nitrate salt. This condition is necessary to achieve a constant humidity atmosphere above the solution.

9.1.2 Place lid on the vessel (do not seal it with grease), insert the temperature-humidity probe through the opening in the top of the lid (leave the stopper out), and set the oven to 55°C .

temperature as needed to stabilize the vessel at 50°C .

9.1.4 Fill the glass dish half-full with sulfur (break up any large lumps), and place the dish on supports above the potassium nitrate solution or float the dish directly on the solution (see Fig. 1).

9.1.5 Replace the lid and insert the vented stopper in the lid opening. Monitor the vessel temperature over several hours, and adjust oven temperature as needed to keep the vessel at $50 \pm 2^\circ\text{C}$ ($122 \pm 4^\circ\text{F}$). When stability has been attained, and the relative humidity is in the 86 to 90 % range, the apparatus is ready for insertion of test samples.

NOTE 3—The system described in this section may be reused for many subsequent tests without replacing the chemicals, and will remain stable for up to 6 months as long as the chemicals do not become contaminated with corrosion products or dirt. If allowed to cool, the potassium nitrate mixture will solidify, but it will liquify again when the vessel is reheated and the solution stirred. Crusts and lumps of hardened potassium nitrate should be broken up and stirred into the slurry. Add a few millilitres of deionized water if necessary to return the solution to its original condition.

9.2 Preparation of Test Samples:

9.2.1 Handle samples as little as possible, even prior to cleaning, and only with tweezers, microscope lens tissue, or clean soft cotton gloves.

9.2.2 Prior to being cleaned, the samples shall be prepared so that the measurement areas may be viewed easily through the microscope. If samples are part of assembled products, they may need to be disassembled to ensure proper access to these areas by the test environment. Since the test is specific to the planted metallic portions of the product, the latter should be separated from plastic housings, etc., whenever possible, prior to cleaning. Also, nonmetallic materials, such as paper tags, string, tape, etc., shall be removed, but take care to maintain sample identity.

9.2.3 Cleaning:

⁷ Fisher catalogue no. S-591 or WWR Scientific catalogue no. JT4088 have been found satisfactory for this purpose.

9.2.3.1 Inspect the samples under 10× magnification for evidence of particulate matter. If present, such particles should be removed by “dusting” (that is, blowing them off the sample) with clean, oil-free air.

NOTE 4—An aerosol-can “duster” or a photographer’s brushblower are convenient tools for this purpose.

9.2.3.2 Thoroughly clean the particle-free samples with solvents or solutions that do not contain CFCs, chlorinated hydrocarbons, or other known ozone-destroying compounds. The procedure outline in Note 5 has been found to give satisfactory results for coatings with mild to moderate surface contamination.

NOTE 5—Suggested cleaning procedure:

(1) Keep individual pieces separated if there is a possibility of damage to the measurement areas during the various cleaning steps.

(2) Clean samples for 5 min in an ultrasonic cleaner that contains a hot (65 to 85°C) 2 % aqueous solution of a mildly alkaline (pH 7.5 to 10) detergent.

(3) After ultrasonic cleaning, rinse samples thoroughly under warm running tap water for at least 5 s.

(4) Rinse samples ultrasonically for 2 min in fresh deionized water to remove the last detergent residues.

(5) Immerse in fresh analytical reagent-grade methanol or isopropanol, and ultrasonically agitate for at least 30 s in order to remove the water from the samples.

(6) Remove and dry samples until the alcohol has completely evaporated. If an air blast is used as an aid to drying, the air shall be oil free, clean, and dry.

(7) do not touch the measurement area of the samples with bare fingers after cleaning.

9.2.3.3 Reinspect the samples (under 10× magnification) for particulate matter on the surface. If particulates are found, repeat the cleaning step. Surface cleanliness is extremely important. Contaminants, such as plating salts and flakes of metal, may give erroneous indications of porosity.

9.3 Place the clean samples in the test vessel, in as quick a manner as possible, in order to minimize deviations from equilibrium conditions. A clean, unplated copper or copper-alloy panel should also be put into the vessel each time a test is run as an internal control, that is, to show that the test system is operative. The copper should start to darken within a few hours.

9.4 During the first 1 to 2 h of the test run, leave the desiccator slightly open, by removing the vented stopper, in order to prevent moisture condensation while the system is coming to test temperature. When the test temperature is reached and the relative humidity is in the 86 to 90 % range (which may take 1 to 2 h), replace the vented stopper.

9.5 During the first 2 to 3 h of exposure, check temperature and humidity in the desiccator and record it at suitable intervals in order to ensure the attainment of equilibrium conditions. The same shall be done towards the end of the test.

9.6 Continue the test for the required time; this shall be 24 h, unless otherwise specified. The test system may be left overnight (or over the weekend for a 3-day test), without further monitoring.

9.7 At the end of the test, remove the samples, replace the vessel lid, and allow the samples to cool to room temperature before examining them.

9.8 For all subsequent runs, eliminate the procedure described in 9.1. However, make routine checks of the actual temperature and humidity within the vessel; occasional stirring of the potassium nitrate solution may be required before a new run.

10. Examination and Evaluation

10.1 Examine the measurement areas at 10× magnification using an incandescent or circular fluorescent lamp. The presence of brown or black tarnish spots indicates that the finish is porous at these sites down to the silver or copper-alloy substrate.

10.2 If the pore sites are to be counted, the following may be useful as an aid to counting:

10.2.1 Count only tarnish and corrosion products that are brown to black.

10.2.2 Do not consider loose contamination that can easily be removed by mild air dusting as tarnish or corrosion products.

10.2.3 Move sample around under the light to vary the angle to verify pore indications. Burnished gold can give the appearance of black spots.

10.3 Measure and count a tarnish or corrosion spot when at least three-quarters of the spot falls within the measurement area. Tarnish creepage films which initiate outside the measurement area but fall within it, shall not be counted (see Fig. 2). However, the presence of significant tarnish creepage

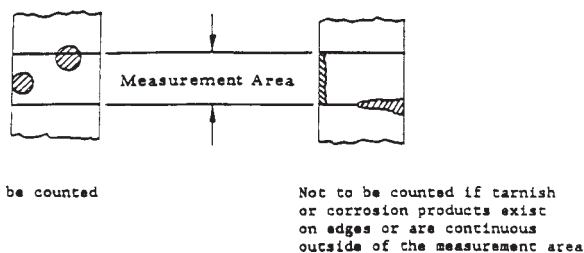

FIG. 2 Corrosion Products at Boundaries of Measurement Area

should be recorded and its location given.

10.4 Pore size shall be defined by the longest diameter of the corrosion product. Unless otherwise specified, corrosion products smaller than 0.05 mm (0.002 in.) in diameter shall not be counted. A graduated reticle in the microscope eyepiece is useful as an aid to counting and sizing.

NOTE 6—A useful sizing technique is to tabulate the pores in accordance with three size ranges: These are, approximately: (a) 0.12 mm (0.005 in.) diameter or less, (b) between 0.12 and 0.40 mm (0.005 and 0.015 in.) diameter, and (c) greater than 0.4 mm (0.015 in.) diameter.

10.5 The acceptable number, size, and location of these tarnish or corrosion spots shall be as specified in the appropriate drawing or specification

11. Precision and Bias

11.1 *Precision*—The precision of this test method is being investigated using gold-plated and nickel-plated coupons.

11.2 *Bias*—The porosity of commercially produced metallic coatings is a property with potentially large sample-to-sample variability.⁸ Since there is no acceptable reference material suitable for determining the bias for porosity testing, no statement on bias is being made.

⁸ Krumbein, S. J., and Holden, Jr., C. A., “Porosity Testing of Metallic Coatings,” *Testing of Metallic and Inorganic Coatings, ASTM STP 947*, Harding, W. B., and DiBari, G. A., eds., ASTM, 1987, p. 193.

ASTM International takes no position respecting the validity of any patent rights asserted in connection with any item mentioned in this standard. Users of this standard are expressly advised that determination of the validity of any such patent rights, and the risk of infringement of such rights, are entirely their own responsibility.

This standard is subject to revision at any time by the responsible technical committee and must be reviewed every five years and if not revised, either reapproved or withdrawn. Your comments are invited either for revision of this standard or for additional standards and should be addressed to ASTM International Headquarters. Your comments will receive careful consideration at a meeting of the responsible technical committee, which you may attend. If you feel that your comments have not received a fair hearing you should make your views known to the ASTM Committee on Standards, at the address shown below.

This standard is copyrighted by ASTM International, 100 Barr Harbor Drive, PO Box C700, West Conshohocken, PA 19428-2959, United States. Individual reprints (single or multiple copies) of this standard may be obtained by contacting ASTM at the above address or at 610-832-9585 (phone), 610-832-9555 (fax), or service@astm.org (e-mail); or through the ASTM website (www.astm.org).