



Standard Test Method for Reliability of Glass Coatings on Glassed Steel Reaction Equipment by High Voltage¹

This standard is issued under the fixed designation C 537; the number immediately following the designation indicates the year of original adoption or, in the case of revision, the year of last revision. A number in parentheses indicates the year of last reapproval. A superscript epsilon (ϵ) indicates an editorial change since the last revision or reapproval.

1. Scope

1.1 This test method covers the determination of the reliability of glass coating on metal and is intended for use by manufacturers of equipment that is designed to withstand highly corrosive conditions where a failure of the coating in service would cause extreme damage to the exposed metal. Its use outside the manufacturer's plant is discouraged because improper or indiscriminate testing can cause punctures that are difficult to repair without returning the equipment to the manufacturer's plant. This test method detects not only existing discontinuities in the glass coating, but also areas where the glass may be thin enough to be likely to result in premature failure in service.

1.2 *This standard does not purport to address all of the safety concerns, if any, associated with its use. It is the responsibility of the user of this standard to establish appropriate safety and health practices and determine the applicability of regulatory limitations prior to use. For specific precautionary statements, see Section 7.*

2. Terminology

2.1 Definition:

2.1.1 *glassed steel, glass-lined steel, or glass-coated steel*—designations generally applied to a class of porcelain enamels that have high resistance to chemical attack at elevated temperatures and pressures.

3. Summary of Test Method

3.1 This test method consists essentially of grounding the metal structure of the equipment to the ground side of a direct-current high-voltage generator and sweeping the glass surface with a high-potential probe on the end of an insulated

handle and cable. Wherever a discontinuity exists or the coating is thin enough (by reason of a concealed bubble or conducting inclusion, etc.) so that the dielectric strength of the remaining glass is less than some preset desired amount, the dielectric strength of air-plus-remaining-glass breaks down and a discharge occurs. Built-in current-limiting devices ensure electrical safety to the operator. A variable voltage control allows selection of a voltage which assures a predetermined minimum thickness of glass.

4. Significance and Use

4.1 The widespread use of glassed-steel equipment in highly corrosive chemical processes has made it necessary to detect weak spots in the coating and repair them before catastrophic failure occurs in service. This test is intended to detect discontinuities and thin areas in a glass coating on metal to ensure that the coating is defect free and has sufficient thickness to withstand the prescribed service conditions. A test voltage may be selected at any desired value up to 20 000 V, thus making the test applicable to a wide range of thickness requirements. When, because of bubbles or defects, the thickness of glass at any spot is less than enough to withstand the applied voltage, a puncture results with an accompanying indication of a defect. Remedial action is then required to repair the defect before the equipment can be used for corrosive service. (When such defects are found before the equipment leaves the manufacturer's plant another application of glass can usually be applied and fired to become an integral part of the coating.)

5. Interferences

5.1 Since the test method is electrical, it is necessary to have a good ground connection between the instrument and the metal substrate of the equipment being tested. It is also necessary that the surface of the glass be reasonably clean and dry. A wet surface will conduct enough of the high voltage to any exposed metal, including the edges of the glass coating, so

¹ This test method is under the jurisdiction of ASTM Committee B-8 on Metallic and Inorganic Coatings and is the direct responsibility of Subcommittee B08.12 on Materials for Porcelain Enamel and Ceramic-Metal Systems.

Current edition approved Aug. 28, 1987. Published October 1987. Originally published as C 537 – 64 T. Last previous edition C 537 – 82.

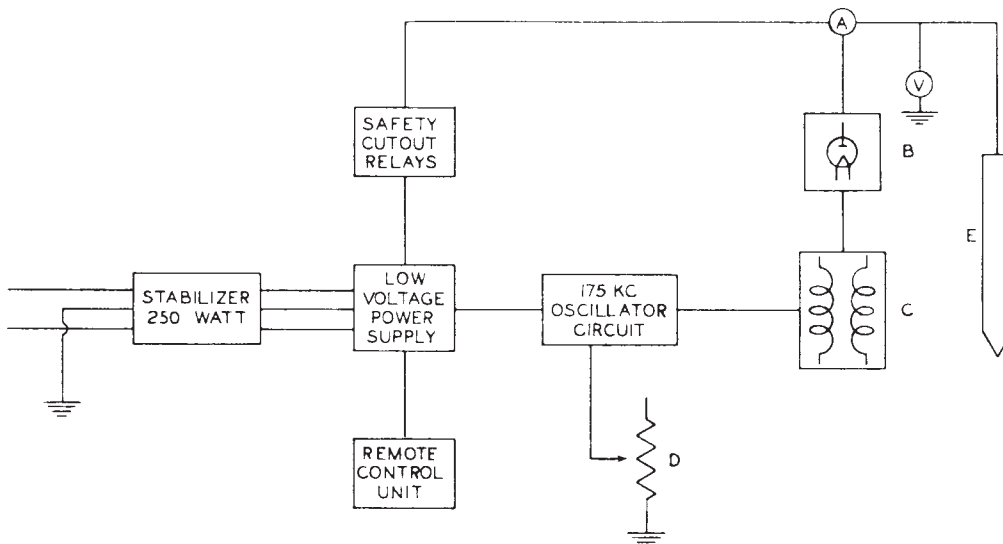

FIG. 1 Circuit Diagram, 20 000-V D-C Tester

that an indication of a “contact” may be obtained over a large area instead of at localized spots that can be marked and identified for repair.

6. Apparatus²

6.1 The tester is composed of a source of high-voltage direct current with a suitable device to limit the current. A constant-voltage transformer is used to supply a more uniform voltage source than the usual 115-V, 60-Hz line to which it is connected. The power supply unit consists of a suitable step-up transformer along with a voltage-control device, a current-limiting rheostat, a rectifier, and appropriate safety and remote control relays, meters, as well as an insulated cable and probe (see Fig. 1 for schematic wiring diagram). The current output is limited to 2.5 mA. The output voltage is variable up to 20 000 V, and the level is indicated by a voltmeter. The handle is insulated and grounded and is designed to use either a wire brush-type or a point probe. The brush probe is used for sweeping larger surfaces of glass coating while the point probe is better adapted to interior corners and the more restricted areas.

7. Safety Precautions

7.1 The instrument and equipment being tested should be well grounded both to a good ground and to each other. All grounding contacts should be clean bare metal and not rusted or painted metal.

7.2 Handle the insulated probe handle so that the hand contacts the ground ring to prevent build-up of a static charge which causes an unpleasant (although not dangerous) sensation on discharge.

7.3 Keep the probe electrode at least 305 mm (12 in.) away from conducting surfaces or personnel. Remember that con-

ducting surfaces may lead to personnel at some distance from the probe. Discharge the probe tip by grounding it after turning off the instrument and before changing probe tips. Although the current is low enough to be electrically safe, the involuntary reaction from a surprise discharge might cause injury.

7.4 Unless the surface to be tested is clean and dry, there may be sufficient conduction along the surface to cause a capacitance discharge even if there is no direct path to ground. Such a capacitance discharge is recognizable from a true failure because the discharge spark is not confined to certain spots but is a general discharge to a large area of the moist glass surface. Continuous application of the probe to such areas serves only to build up a capacitance charge on the surface of the vessel eventually resulting in a discharge through the operator to his discomfort.

7.5 A d-c tester should never be used in a chemical plant for discontinuity testing because of the possibility that a capacitive charge will be developed in the dielectric coating, resulting in an explosion hazard.

8. Procedure

8.1 The following procedure is applicable to commercially available test equipment:

8.1.1 Install ground connections to the instrument and to the equipment to be tested. Provide a separate ground connection between the instrument and the equipment.

8.1.2 Set the voltage-control knob near the minimum setting, connect the instrument to the voltage stabilizer, and connect the latter to the appropriate power line. Turn the power on and allow the test equipment to warm up for 2 to 3 min to ensure stabilization of the voltage.

8.1.3 Engage the overload relay and then the “DC On” switch to apply voltage to the probe.

8.1.4 Hold the probe by the handle with a firm grip on the ground ring and with the electrode well away from all objects and personnel, and slowly raise the voltage until the voltmeter indicates the desired value. Maintain hand contact with the ground ring of the handle all through the test to avoid a buildup

² A suitable apparatus meeting these specifications can be obtained from NJE Corp., 22 Boright Ave., Kenilworth, NJ 07033, or Technology Sales and Marketing Inc., 4872 Clearview Dr., Williamsville, NY 14221. When requesting information, specific reference should be made to the ASTM designation.



of static electricity in the operator that might result in an uncomfortable and annoying (although not dangerous) spark discharge. Pass the test probe across the coating surface at a speed not to exceed 40 cm/s.

NOTE 1—The instrument is set to discharge across an internal gap at slightly over 20 000 V. If the voltage is set high enough to cause such a discharge, ionization of the air usually causes the arc to persist until the voltage is reduced to approximately 5000 V. Shortly after the arc has extinguished, the voltage can be reset to the desired value.

8.1.5 When a point of failure in the coating is approached, a spark will jump to the point of failure with a visible and audible discharge or arc. As the path of the arc is shortened, by bringing the electrode close to the point of failure, the current in the arc builds up. At a 2.5-mA current in the arc, the overload relay will trip and the d-c current will cut off. When this happens it is necessary to engage first the overload relay and then the “DC On” switch before the tester is again operative.

8.1.6 Mark the point of failure with suitable chalk (or crayon) for subsequent repair.

9. Report

9.1 The report shall include the following:

9.1.1 Title of test, ASTM designation and issue,

9.1.2 Date of test,

9.1.3 Description or identification of equipment being tested,

9.1.4 Voltage used in the test, and

9.1.5 Number and location of failures.

10. Precision and Bias

10.1 No justifiable statements can be made regarding the precision and bias of this test method due to the fact that this method is designed for application to full-sized production vessels and reactors with the result that variables due to design, metal composition, fabrication, and metal processing, as well as porcelain enameling, are introduced into the results.

ASTM International takes no position respecting the validity of any patent rights asserted in connection with any item mentioned in this standard. Users of this standard are expressly advised that determination of the validity of any such patent rights, and the risk of infringement of such rights, are entirely their own responsibility.

This standard is subject to revision at any time by the responsible technical committee and must be reviewed every five years and if not revised, either reapproved or withdrawn. Your comments are invited either for revision of this standard or for additional standards and should be addressed to ASTM International Headquarters. Your comments will receive careful consideration at a meeting of the responsible technical committee, which you may attend. If you feel that your comments have not received a fair hearing you should make your views known to the ASTM Committee on Standards, at the address shown below.

This standard is copyrighted by ASTM International, 100 Barr Harbor Drive, PO Box C700, West Conshohocken, PA 19428-2959, United States. Individual reprints (single or multiple copies) of this standard may be obtained by contacting ASTM at the above address or at 610-832-9585 (phone), 610-832-9555 (fax), or service@astm.org (e-mail); or through the ASTM website (www.astm.org).