



Standard Test Method for Crack-Tip Opening Displacement (CTOD) Fracture Toughness Measurement¹

This standard is issued under the fixed designation E 1290; the number immediately following the designation indicates the year of original adoption or, in the case of revision, the year of last revision. A number in parentheses indicates the year of last reapproval. A superscript epsilon (ϵ) indicates an editorial change since the last revision or reapproval.

1. Scope

1.1 This test method covers the determination of critical crack-tip opening displacement (CTOD) values at one or more of several crack extension events. These CTOD values can be used as measures of fracture toughness for metallic materials, and are especially appropriate to materials that exhibit a change from ductile to brittle behavior with decreasing temperature. This test method applies specifically to notched specimens sharpened by fatigue cracking. The recommended specimens are three-point bend [SE(B)] compact [C(T)], or arc-shaped bend [A(B)] specimens. The loading rate is slow and influences of environment (other than temperature) are not covered. The specimens are tested under crosshead or clip gage displacement controlled loading.

1.1.1 The recommended specimen thickness, B , for the SE(B) and C(T) specimens is that of the material in thicknesses intended for an application. For the A(B) specimen, the recommended depth, W , is the wall thickness of the tube or pipe from which the specimen is obtained. Superficial surface machining may be used when desired.

1.1.2 For the recommended three-point bend specimens [SE(B)], width, W , is either equal to, or twice, the specimen thickness, B , depending upon the application of the test. (See 4.3 for applications of the recommended specimens.) For SE(B) specimens the recommended initial normalized crack size is $0.45 \leq a_o/W \leq 0.70$. The span-to-width ratio (S/W) is specified as 4.

1.1.3 For the recommended compact specimen [C(T)] the initial normalized crack size is $0.45 \leq a_o/W \leq 0.70$. The half-height-to-width ratio (H/W) equals 0.6 and the width to thickness ratio W/B is specified to be 2.

1.1.4 For the recommended arc-shaped bend [A(B)] specimen, B is one-half the specimen depth, W . The initial normalized crack size is $0.45 < a_o/W < 0.55$. The span to width ratio, S/W , may be either 3 or 4 depending on the ratio of the inner to outer tube radius. For an inner radius, r_1 , to an outer radius, r_2 , ratio of > 0.6 to 1.0, a span to width ratio, S/W , of 4 may be used. For r_1/r_2 ratios from 0.4 to 0.6, an S/W of 3 may be used.

¹ This test method is under the jurisdiction of ASTM Committee E-8 on Fatigue and Fracture and is the direct responsibility of Subcommittee E08.08 on Elastic-Plastic Fracture Mechanics Technology.

Current edition approved June 10, 1999. Published September 1999. Originally published as E 1290 – 89. Last previous edition E 1290 – 93.

1.2 *This standard does not purport to address all of the safety concerns, if any, associated with its use. It is the responsibility of the user of this standard to establish appropriate safety and health practices and determine the applicability of regulatory limitations prior to use.*

2. Referenced Documents

2.1 ASTM Standards:

- E 4 Practices for Force Verification of Testing Machines²
- E 8 Test Methods for Tension Testing of Metallic Materials²
- E 399 Test Method for Plane-Strain Fracture Toughness of Metallic Materials²
- E 1820 Test Method for Measurement of Fracture Toughness²
- E 1823 Terminology Relating to Fatigue and Fracture Testing²

3. Terminology

3.1 Terminology E 1823 is applicable to this test method.

3.2 Definitions:

3.2.1 *crack tip opening displacement, (CTOD), $\delta[L]$* —the crack displacement due to elastic and plastic deformation at variously defined locations near the original (prior to an application of force) crack tip.

3.2.1.1 *Discussion*—In this test method, CTOD is the displacement of the crack surfaces normal to the original (unloaded) crack plane at the tip of the fatigue precrack, a_o .

In CTOD testing, $\delta_c[L]$ is the value of CTOD at the onset of unstable brittle crack extension (see 3.2.13) or pop-in (see 3.2.7) when $\Delta a_p < 0.2$ mm (0.008 in.). The force P_c and the clip gage displacement v_c , for δ_c are indicated in Fig. 1.

In CTOD testing, $\delta_u[L]$ is the value of CTOD at the onset of unstable brittle crack extension (see 3.2.13) or pop-in (see 3.2.7) when the event is preceded by $\Delta a_p > 0.2$ mm (0.008 in.). The force P_u and the clip gage displacement v_u , for δ_u are indicated in Fig. 1.

In CTOD testing, $\delta_m[L]$ is the value of CTOD at the first attainment of a maximum force plateau for fully plastic behavior. The force P_m and the clip gage displacement v_m , for δ_m are indicated in Fig. 1.

3.2.2 *effective yield strength, $\sigma_Y [FL^{-2}]$* —an assumed value of uniaxial yield strength that represents the influence of plastic

² Annual Book of ASTM Standards, Vol 03.01.

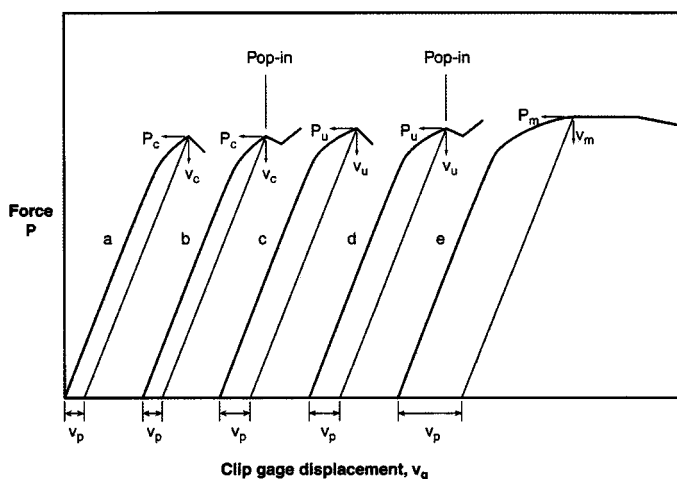

NOTE 1—Construction lines drawn parallel to the elastic loading slope to give v_p , the plastic component of total displacement, v_g .

NOTE 2—In curves b and d, the behavior after pop-in is a function of machine/specimen compliance, instrument response, etc.

FIG. 1 Types of Force Versus Clip Gage Displacement Records

yielding upon fracture test parameters.

3.2.2.1 *Discussion*—The calculation of σ_Y is the average of the 0.2 % offset yield strength (σ_{YS}), and the tensile strength (σ_{TS}), that is $(\sigma_{YS} + \sigma_{TS})/2$. Both σ_{YS} and σ_{TS} are determined in accordance with Test Methods E 8.

3.2.3 *original crack size, a_o [L]*—see Terminology E 1823.

3.2.4 *original uncracked ligament, b_o [L]*—the distance from the original crack front to the back surface of the specimen at the start of testing, $b_o = W - a_o$.

3.2.5 *physical crack extension, Δa_p [L]*—an increase in physical crack size, $\Delta a_p = a_p - a_o$.

3.2.6 *physical crack size, a_p [L]*—see Terminology E 1823.

3.2.6.1 *Discussion*—In CTOD testing, $a_p = a_o + \Delta a_p$.

3.2.7 *pop-in*—a discontinuity in the force versus clip gage displacement record. The record of a pop-in shows a sudden increase in displacement and, generally, a decrease in force. Subsequently, the displacement and force increase to above their respective values at pop-in.

3.2.8 *slow stable crack extension [L]*—a displacement controlled crack extension beyond the stretch zone width (see 3.2.12). The extension stops when the applied displacement is held constant.

3.2.9 *specimen span, S [L]*—the distance between specimen supports in a bend specimen.

3.2.10 *specimen thickness, B [L]*—see Terminology E 1823.

3.2.11 *specimen width, W [L]*—see Terminology E 1823.

3.2.12 *stretch zone width, SZW [L]*—the length of crack extension that occurs during crack-tip blunting, for example, prior to the onset of unstable brittle crack extension, pop-in, or slow stable crack extension. The SZW is in the same plane as the original (unloaded) fatigue precrack and refers to an extension beyond the original crack size.

3.2.13 *unstable brittle crack extension [L]*—an abrupt crack extension that occurs with or without prior stable crack extension in a standard test specimen under crosshead or clip gage displacement control.

4. Summary of Test Method

4.1 The objective of the test is to determine the value of

CTOD at one or more of several crack extension events. The values of CTOD may correspond to: δ_c , the onset of unstable brittle crack extension with no significant prior slow stable crack extension (see 3.2.1); δ_u , the onset of unstable brittle crack extension following prior slow stable crack extension; δ_m , at the first attainment of a maximum force plateau for fully plastic behavior.

4.2 The test method involves crosshead or clip gage displacement controlled three-point bend loading or pin loading of fatigue precracked specimens. Force versus clip gage crack opening displacement is recorded, for example, Fig. 1. The forces and displacements corresponding to the specific events in the crack initiation and extension process are used to determine the corresponding CTOD values. For values of δ_c , δ_u and δ_m , the corresponding force and clip gage displacements are obtained directly from the test records.

4.3 The rectangular section bend specimen and the compact specimen are intended to maximize constraint and these are generally recommended for those through-thickness crack types and orientations for which such geometries are feasible. For the evaluation of surface cracks in structural applications for example, orientations T-S or L-S (Terminology E 1823), the square section bend specimen is recommended. Also for certain situations in curved geometry source material or welded joints, the square section bend specimen may be preferred. Square section bend specimens may be necessary in order to sample an acceptable volume of a discrete microstructure.

4.4 The arc-shaped bend specimen permits toughness testing in the C-R orientation (Terminology E 1823), for pipe or tube. This orientation is of interest since pipes and tubes under pressure often fail with longitudinal cracks. The specimen geometry is convenient for obtaining samples with minimal use of material.

5. Significance and Use

5.1 This test method characterizes the fracture toughness of materials through the determination of crack-tip opening displacement (CTOD) at one of three events: (a) onset of unstable

ASTM E 1290

crack extension without significant prior stable crack extension, (b) onset of unstable crack extension with significant prior stable crack extension, or (c) achievement of plastic limit load with or without significant stable crack extension. This test method may also be used to characterize the toughness of materials for which the properties and thickness of interest preclude the determination of K_{Ic} fracture toughness in accordance with Test Method E 399.

5.2 The different values of CTOD determined by this test method characterize the resistance of a material to crack initiation and early crack extension at a given temperature.

5.3 The values of CTOD may be affected by specimen dimensions. It has been shown that values of CTOD determined on SE(B) specimens using the square section geometry may not be the same as those using the rectangular section geometry, and may differ from those obtained with either the (C)T or (A)B specimens.

5.4 The values of CTOD determined by this test method may serve the following purposes:

5.4.1 In research and development, CTOD testing can show the effects of certain parameters on the fracture toughness of metallic materials significant to service performance. These parameters include material composition, thermo-mechanical processing, welding, and thermal stress relief.

5.4.2 For specifications of acceptance and manufacturing quality control of base materials, weld metals, and weld heat affected zones.

5.4.3 For inspection and flaw assessment criteria, when used in conjunction with fracture mechanics analyses. Awareness of differences that may exist between laboratory test and field conditions is required to make proper flaw assessment (see 4.3 and 4.4).

6. Apparatus

6.1 This procedure involves measurement of applied force, P , and clip gage crack opening displacement, v . Force versus

displacement is autographically recorded on an x - y plotter for visual display, or converted to digital form for accumulation in a computer information storage facility and subsequent processing. Testing is performed under crosshead or clip gage displacement control in a compression or tension testing machine, or both, that conforms to the requirements of Practices E 4.

6.2 *Fixturing for Three-Point Bend Specimens*—A recommended SE(B) or A(B) specimen fixture is shown in Fig. 2. Friction effects between the support rollers and specimen are reduced by allowing the rollers to rotate during the test. The use of high hardness steel of the order of 40 HRC or more is recommended for the fixture and rollers to prevent indentation of the platen surfaces.

6.3 *Tension Testing Clevis*—A loading clevis suitable for testing C(T) specimens is shown in Fig. 3. Each leg of the specimen is held by such a clevis and loaded through pins, in order to allow rotation of the specimen during testing. To provide rolling contact between the loading pins and the clevis holes, these holes are produced with small flats on the loading surfaces. Other clevis designs may be used if it can be demonstrated that they will accomplish the same result as the design shown. Clevises and pins should be fabricated from steels of sufficient strength and hardness (greater than 40 HRC) to elastically resist indentation forces. The critical tolerances and suggested proportions of the clevis and pins are given in Fig. 3. These proportions are based on specimens having $W/B = 2$ for $B > 12.7$ mm (0.5 in.) and $W/B = 4$ for $B \leq 12.7$ mm (0.5 in.). If a 1930-MPa (280 000-psi) yield strength maraging steel is used for the clevis and pins, adequate strength will be obtained. If lower strength grip material is used, or if substantially larger specimens are required at a given σ_{ys}/E ratio, then heavier grips will be required. As indicated in Fig. 3, the clevis corners may be cut off sufficiently to accommodate seating of the clip gage in specimens less than 9.5 mm (0.375 in.) thick.

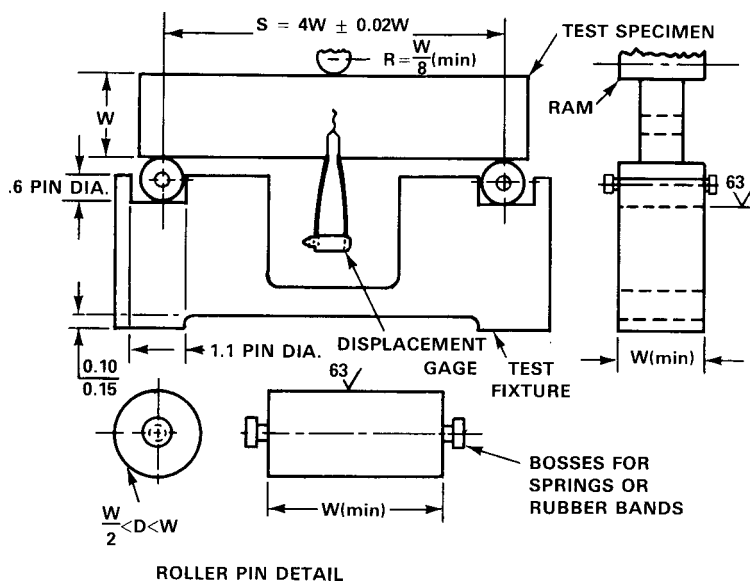
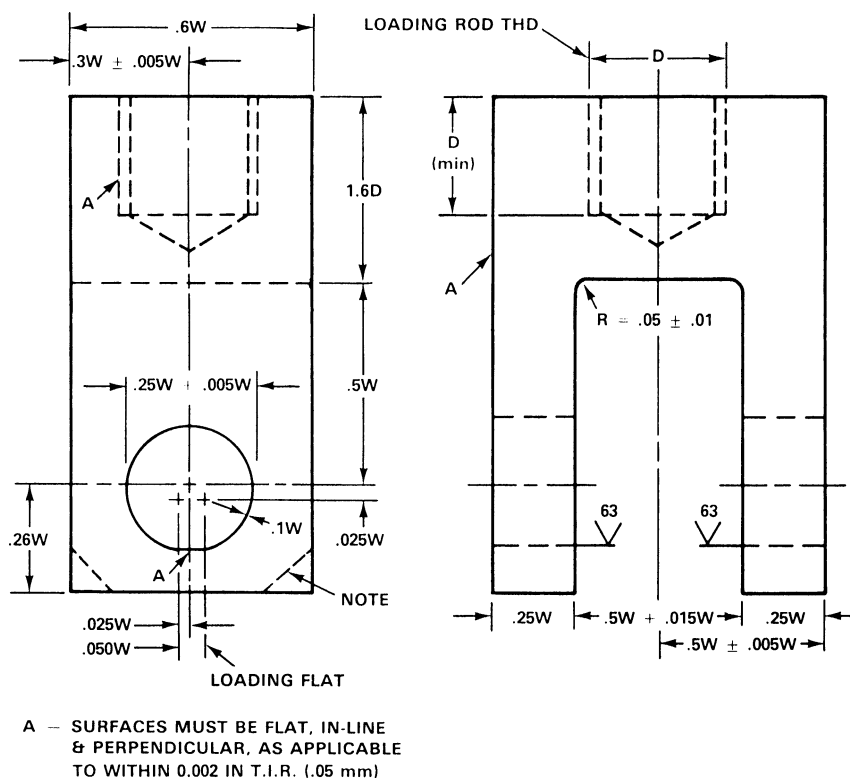

FIG. 2 SE(B) Test Fixture Design

NOTE 1—Roller pins and specimen contact surface of loading ram must be parallel to each other within 0.002W.

NOTE 2—0.10 in. = 2.54 mm; 0.15 in. = 3.81 mm.

E 1290



NOTE 1—Corners of the clevis may be removed as necessary to accommodate the clip gage.

FIG. 3 Clevis for C(T) Specimen Testing

Attention should be given to achieving good alignment through careful machining of all auxiliary gripping fixtures.

6.4 Displacement Measuring Devices:

6.4.1 Displacement measuring gages are used to measure opening displacements on SE(B) specimens at either knife edges a distance z beyond the crack mouth, Fig. 4a, or at the crack mouth ($z = 0$) in the case of integral knife edges, Fig. 4b. For C(T) specimens, where the opening displacement is not measured on the load line, the difference between the load line and the displacement measuring point shall constitute the dimension z (see 9.2). Alternatively, when the opening displacements on C(T) specimens are made on or within $\pm 0.002 W$ of the load line, it may be assumed that $z = 0$. For A(B) specimens, special measurements must be taken to establish location of the clip gage knife edges with respect to the crack plane. Paragraphs 8.9.4 and 8.9.5 provide more detail on required measurements.

6.4.2 The clip gage recommended in Test Method E 399 may be used in cases where the total expected displacement is 2.5 mm (0.1 in.) or less. Sensitivity and linearity requirements specified in Test Method E 399, shall be met over the full working range of the gage. In addition, the gage is to be calibrated to within $\pm 1\%$ of the working range.

6.4.3 For cases where a linear working range of up to 8 mm (0.3 in.) or more is needed, an enlarged gage such as that shown in Fig. 5 can be used. Both linearity and accuracy of the equipment or system used shall be demonstrated to be within $\pm 1\%$ of the working range of the equipment.

6.4.4 The seating between the clip gage and knife edges shall be firm and free from friction drag.

6.5 *Force Measurement*—The sensitivity of the force sensing device shall be sufficient to avoid distortion caused by over amplification and the device shall have a linearity identical to that for the displacement signal. The combination of force sensing device and recording system shall permit the force P to be determined from the test record within an accuracy of $\pm 1\%$.

7. Specimen Configurations, Dimensions, and Preparation

7.1 The SE(B) specimens, shown in Fig. 6 and Fig. 7, are tested with a span to width ratio, S/W , of 4. Therefore, it is suggested that overall specimen length should be at least $4.5 W$.

7.1.1 The standard bend specimens shall be of thickness, B , at least equal to that employed in the specific structural application of interest, or the original product form thickness. The specimen should be one of the types shown in Fig. 6 and Fig. 7.

7.1.2 The recommended original crack size, a_o , of the SE(B) specimen shall be within the range $0.45 W \leq a_o \leq 0.70 W$.

7.1.3 In order to machine fatigue crack-starter notches to depths greater than 2.5 mm (0.1 in.), a stepped width notch is an allowed exception. This is acceptable, provided that: (a) the stepped width notch falls completely within the envelope shown in Fig. 8, and, (b) the length of the fatigue precrack extension from the machined notch tip satisfies the requirement of 7.4.2. Separate or integral knife edges for accommodating clip gages are shown in Fig. 4.

7.2 The recommended C(T) specimen designs are shown in Fig. 9. These are similar to the configurations recommended in

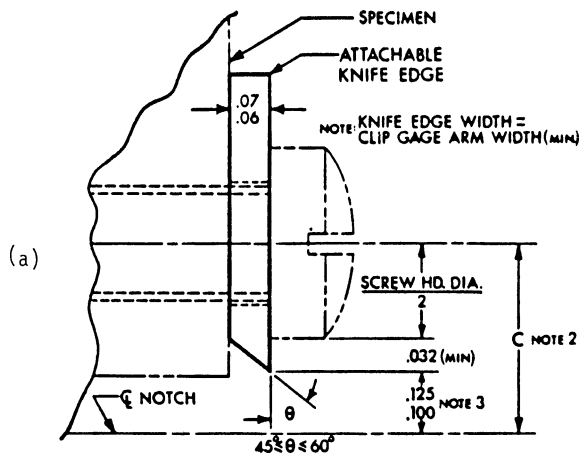

NOTE 1—Dimensions are in inches.

NOTE 2—Effective gage length = $2C + \text{Screw Thread Diameter} \leq W/2$. (This will always be greater than the gage length specified in Test Method E 399, A 1.1.)

NOTE 3—Dimension shown corresponds to clip gage spacer block dimension in Test Method E 399, Annex A1 .

		Metric Equivalents				
in.	0.032	0.06	0.07	0.100	0.125	
mm	0.81	1.5	1.8	2.54	3.18	

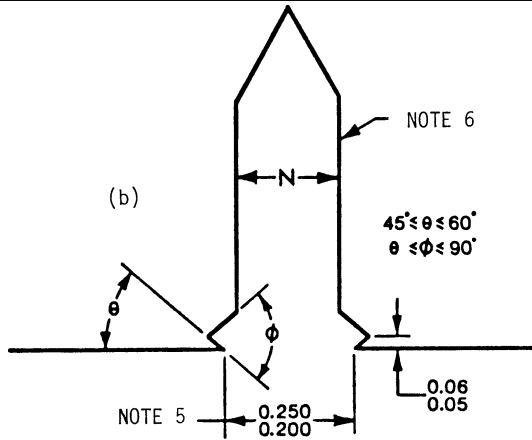

NOTE 4—Dimensions in inches.

NOTE 5—Gage length shown corresponds to clip gage spacer block dimensions shown in Test Method E 399, Annex A1 , but other gage lengths may be used provided they are appropriate to the specimen.

NOTE 6—For starter notch configurations see Fig. 8

		Metric Equivalents			
in.	0.050	0.060	0.200	0.250	
mm	1.3	1.5	5.1	6.4	

FIG. 4 Knife Edges for Location of Clip Gages

Test Method E 1820. The designs are suitable for use with flat bottom clevises of Test Method E 399 design (see Fig. 3). A cut-out section on the front face provides room to attach razor blade edges on the load line of the specimen. The sharp edges of the blades shall be square with respect to specimen surfaces and parallel within 0.5° . A specially prepared spacer block can be used to achieve these requirements.

7.2.1 The C(T) specimen shall be of thickness, B , at least equal to that employed in the specific structural application of interest, or the original product form thickness.

7.2.2 The C(T) specimen half-height to width ratio H/W is

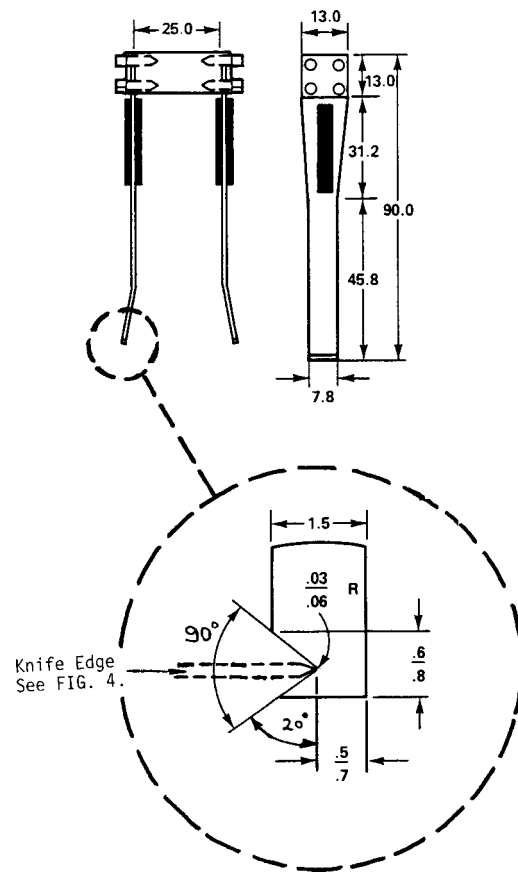

NOTE 1—All dimensions in mm.

FIG. 5 Clip Gage Design for 8-mm (0.3-in.) and More Working Range (see 6.4.3.)

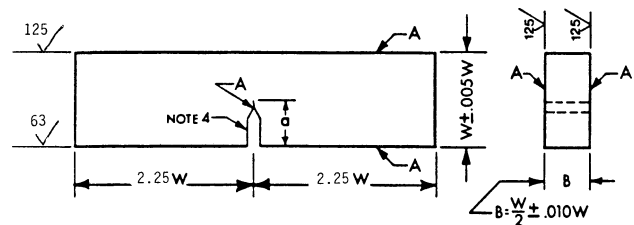

NOTE 1—A surfaces shall be perpendicular and parallel as applicable within $0.001 W$ TIR.

NOTE 2—Crack starter notch shall be perpendicular to specimen surfaces to within $\pm 2^\circ$.

NOTE 3—Integral or attachable knife edges for clip gage attachment may be used (see Fig. 4).

NOTE 4—For starter notch and fatigue crack configurations see Fig. 8.

FIG. 6 Proportional Dimensions and Tolerances for Rectangular Section SE(B) Specimens

0.6, and the width W to thickness B ratio W/B is specified to be 2.

7.2.3 The original crack length, a_o , of the compact specimen shall be within the range $0.45 W \leq a_o \leq 0.70 W$.

7.3 The arc-shaped bend specimen (1)³ is a single-edge notched and fatigue cracked ring segment loaded in bending.

³ The boldface numbers in parentheses refer to the list of references at the end of this test method.

E 1290

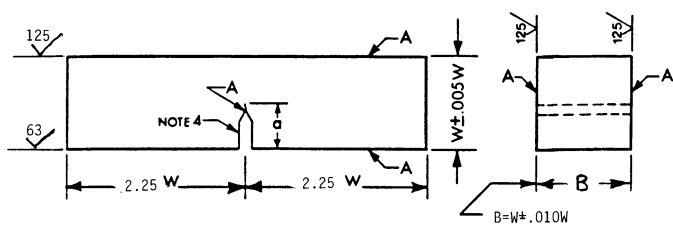

NOTE 1—A surfaces shall be perpendicular and parallel as applicable within 0.001 W TIR.

NOTE 2—Crack starter notch shall be perpendicular to specimen surfaces to within $\pm 2^\circ$.

NOTE 3—Integral or attachable knife edges for clip gage attachment may be used (see Fig. 4).

NOTE 4—For starter notch and fatigue crack configurations see Fig. 8.

FIG. 7 Proportional Dimensions and Tolerances for Square Section SE(B) Specimens

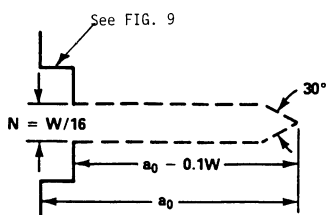

ENVELOPE

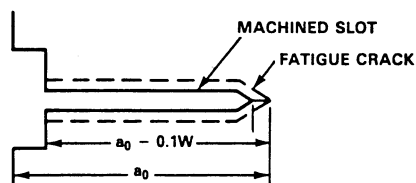

ACCEPTABLE NOTCH

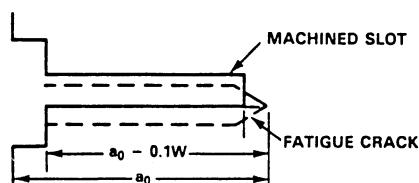

UNACCEPTABLE NOTCH

NOTE 1—N must not exceed W/16.

NOTE 2—The intersection of the crack starter surfaces with the two specimen faces shall be equidistant from the top and bottom edges of the specimen within 0.005 W.

FIG. 8 Envelope of Crack-Starter Notches

The general proportions of the standard specimen are shown in Fig. 10. The value of the radius ratio r_1/r_2 is limited to the range from > 0.6 to 1.0 when the specimen is loaded with a span-to-width ratio S/W of 4, and from 0.4 to 0.6 when the specimen is loaded with a span-to-width ratio S/W of 3.

7.3.1 The arc-shaped bend specimen is intended to measure the fracture toughness so that the normal to the crack plane is in the circumferential direction and the direction of crack propagation is in the radial direction. This is the C-R orientation as defined in Terminology E 1823. For other orientations, the SE(B) or C(T) specimen should be used.

7.3.2 The recommended original crack size, (a_o , of the A(B) specimen shall be within the range from $0.45 W \leq a_o \leq 0.55 W$.

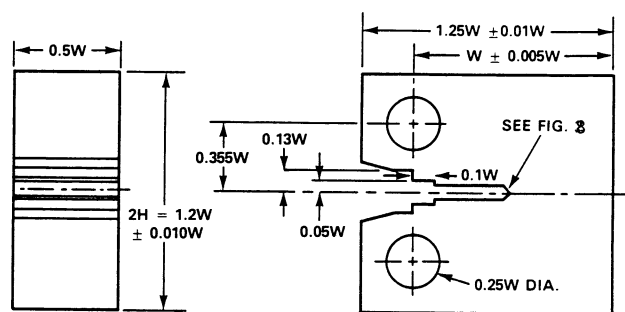

C(T) Specimen for pin of 0.24W (+0.000 W/-0.005W) diameter

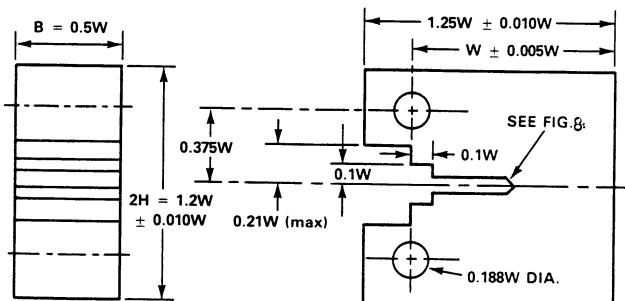

C(T) Specimen for pin of 0.1875W (+0.000W/-0.001W) diameter

FIG. 9 Alternative C(T) Specimen Designs

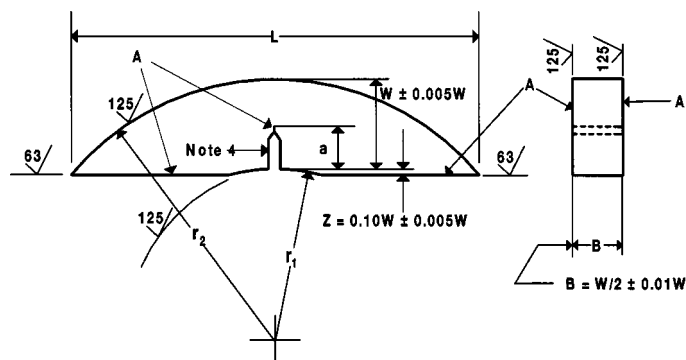

NOTE 1—A surfaces shall be perpendicular and parallel as applicable within 0.0001 W TIR.

NOTE 2—Crack starter notch shall be perpendicular to specimen surfaces to within $\pm 2^\circ$.

NOTE 3—Integral or attachable knife edges for clip gage attachment shall be used (see Fig. 4).

NOTE 4—For starter notch and fatigue crack configuration see Fig. 8.

FIG. 10 Arc-shaped Bend Specimen A(B)—Standard Proportions and Tolerances

7.4 Fatigue Precracking:

7.4.1 All specimens shall be precracked in fatigue at force values no greater than the force P_f calculated in accordance with the following equations.

For SE(B) and A(B) specimens use:

$$P_f = 0.5(Bb_o^2\sigma_y/S) \quad (1)$$

For C(T) specimens use:

$$P_f = 0.4 Bb_o^2\sigma_y/(2W + a_o) \quad (2)$$

7.4.2 The length of the fatigue precrack extension from the machined notch shall not be less than 5 % of the total crack length, a_o , and not less than 1.3 mm (0.05 in.). For the final 50 % of fatigue precrack extension or 1.3 mm (0.05 in.), whichever is less, the maximum force shall be no larger than: (a) P_f , or, (b) a force such that the ratio of stress intensity factor range to Young's modulus ($\Delta K/E$) is equal to or less than $0.005 \text{ mm}^{1/2}$ ($0.001 \text{ in.}^{1/2}$), whichever is less. The accuracy of these maximum force values shall be known within ± 5 %. The ratio of minimum precracking force to maximum precracking force shall not exceed 0.10. The stress intensity range ΔK may be calculated using the formulae in 9.2.

7.4.3 Normally, the fatigue precracking should be done at room temperature with the material in the condition (metallurgical and thermal-mechanical processing) in which it will be tested. Intermediate treatments between fatigue precracking and testing are only allowed when such treatments are used to simulate a specific structural application of interest.

7.4.4 To promote early fatigue crack initiation, and promote planar crack growth, a notch tip radius of 0.08 mm (0.003 in.) or less should be used. Additionally, there may be an advantage in using a Chevron notch (see appropriate figure in Test Method E 399), or by statically preloading the specimen. In the latter case, the specimen is loaded in such a way that the straight-through notch tip is compressed in a direction normal to the intended crack plane, but without allowing the applied force to exceed P_f .

7.4.5 The fatigue crack shall fall within the limiting envelope as shown in Fig. 8.

8. Procedure

8.1 The objective of the procedure described herein is to identify the critical CTOD values that can be used as measures of the fracture toughness of materials. These values are derived from measurements of force and clip gage displacement, as described in Section 9.

8.2 After completion of the test, proceed as follows:

8.2.1 Heat tint or fatigue crack the specimen to mark the amount of slow stable crack extension. If fatigue crack marking is used, this should be done using a maximum cyclic force less than the previously applied monotonic force with the minimum cyclic force equal to 70 % of the maximum cyclic force. The maximum cyclic force should be of sufficient magnitude to prevent damage to the fracture surfaces by crack closure.

8.2.2 Break the specimen open to expose the crack, taking care to minimize additional deformation. Cooling ferritic steels enough to ensure brittle behavior may be helpful.

8.2.3 Measure the original crack length, a_o , and physical crack length after slow stable crack extension, a_p , in accordance with 8.9.5.

8.3 *Testing Rate*—Force the specimen such that the rate of increase of stress intensity factor to the force P_f is within the range from 0.55 to 2.75 MPa $\text{m}^{1/2}/\text{s}$ (30 000 to 150 000 psi $\text{in.}^{1/2}/\text{min}$). Carry out the test under either crosshead or clip gage displacement control (see 6.1 and 10.1.4).

8.4 *Specimen Test Temperature*—Control the specimen test temperature to an accuracy of $\pm 2^\circ\text{C}$ ($\pm 3^\circ\text{F}$). It is recommended that tests be made in situ in suitable low or high

temperature media, as appropriate. In a liquid medium, hold the specimen at least 30 s/mm (12 min/in.) after the specimen surface has reached the test temperature and prior to testing. When using a gaseous medium, use a soaking time significantly longer than 30 s/mm (12 min/in.) of thickness. The determination of an appropriate soaking time in a gaseous medium shall be the responsibility of those conducting the test.

8.5 *SE(B) and A(B) Testing*—Install the bend fixture so that the line of action of the applied force passes mid-way between the support roller centers within 0.5 % of the distance between these centers. Position the specimens with the notch centerline mid-way between the rollers to within 0.5 % of the span, and position square to the roller axes within 2° .

8.6 *C(T) Testing*—To minimize errors from loading pin friction and eccentricity of loading from misalignment, the axes of the loading rods should be kept coincident within 0.8 mm (0.03 in.) during the test. Center the specimen with respect to the clevis opening within 0.8 mm (0.03 in.).

8.7 *Clip Gage Seating*—Seat the displacement gage in the knife or razor edges firmly, by lightly rocking the gage.

8.8 *Recording*:

8.8.1 The test records shall consist of autographic plots or digital records, or both, of the output of the force sensing device versus the output from the clip gage.

8.8.2 *Test Record*—The linear elastic portion of the force versus deflection test record shall exhibit a slope between 0.7 and 1.5. Maximum force can be estimated from $2.5 P_f$, where P_f is as specified for SE(B) and C(T) specimens in 7.4.1.

8.9 *Measurements*—All specimen dimensions shall be within the tolerances shown in Fig. 6, Fig. 7, and Fig. 9.

8.9.1 *Thickness*—Measure the specimen thickness, B , before testing, accurate to the nearest 0.05 mm (0.002 in.) or 0.5 % B , whichever is larger, at three locations along the uncracked ligament of the specimen. Record the average B .

8.9.2 *SE(B) Specimen Width*—Prior to testing, measure the width, W , adjacent to the notch on both sides accurate to the nearest 0.05 mm (0.002 in.) or 0.1 % W , whichever is larger. Record average W .

8.9.3 *C(T) Specimen Width*—Prior to testing, measure the width, W , from the load line to the back edge of the specimen on both sides of the notch, accurate to the nearest 0.05 mm (0.002 in.) or 0.1 % W , whichever is larger. Record average W .

8.9.4 *A(B) Specimen Measurement*—Before testing an arch-shaped bend sample, measure $(r_2 - r_1)$ to the nearest 0.025 mm (0.01 in.) or to 0.1 %, whichever is greater, at mid-thickness positions on both sides of, and immediately adjacent to, the crack starter notch mount (see Fig. 10). Record the average of these two readings as W . Also measure $(r_2 - r_1)$ at four positions, two as close as possible to the intersection of the inside radius and the machined flat surfaces, and two at approximately one half the circumferential distance between the machined flat surfaces and the crack plane. If any of these four measurements differ from W by more than 10 % discard or rework the specimen. Next, measure to the nearest 0.025 mm (0.001 in.) or to the nearest 1 %, whichever is greater, the distance in the crack plane between the chord that connects the two machined flat surfaces and the outer radius of the specimen. This measurement should be performed on both sides of

the specimen referencing each flat machined surface. Subtract W from the average of these two measurements and record the result as Z . Measure within 5 % the distance, g , across the crack mouth at the reference points for the measurement of the crack mouth opening displacement. (For example, $g = 6.3$ mm (0.25 in.) in Fig. 11.) It should be noted that g may be equal to the notch width N , or larger than N if machined knife edges are used. Measure within 5 % of the outer radius, r_2 , if this is not possible, determine the average value of r_2 as follows: Measure within 5 % the length, L , of the chord of the outer surface, that is, the chord established by the flat machined surfaces (see Fig. 10). Using this measurement, calculate

$$r_2 = L^2/8(W + Z) + (W + Z)/2 \quad (3)$$

Then $r_2 r_2 = 1 - W/r_2$.

8.9.5 Crack Length—After completion of the test (and, if necessary, breaking open the specimen after heating tinting or fatigue cracking in accordance with 8.2), examine the fracture surface. Along the front of the fatigue crack, and along the front of any slow stable crack extension, including the SZW, measure the crack length at nine equally spaced points across the specimen thickness, centered about the specimen centerline and extending to 0.005 W from the specimen surfaces. Calculate the original (fatigue) crack length, a_o , and the final physical crack length, a_p (which includes the tear length and SZW), as follows: average the two near-surface measurements, add this result to the remaining seven crack length measurements, and average this total length by dividing by eight (see 9.4 for crack geometry validity criteria). The individual crack length measurements should be accurate to within the nearest 0.03 mm (0.001 in.).

8.9.5.1 Special Requirement for A(B) Specimen—An additional special procedure is necessary for the arc-shaped bend specimen due to its curvature as illustrated in Fig. 11. A length measurement, m , made from a reference point adjacent to the crack mouth to a point on the crack front will be greater than the corresponding distance from the virtual point of intersection between the crack plane and the inside circumference of the specimen (see Fig. 11). The error, e , may be computed from the following expression:

$$e = r_1 - (r_1^2 - g^2/4)^{1/2} \quad (4)$$

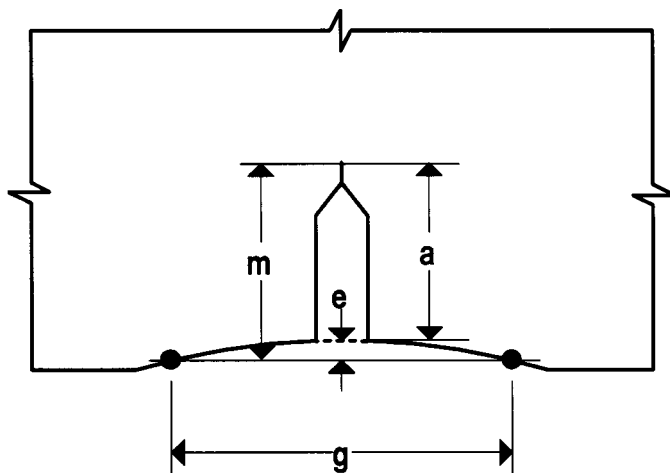

FIG. 11 Measurement of Crack Length for the Arc-shaped Bend Specimen

If the relative error $e/m < 0.01$, then record m as the crack length. Otherwise, e should be subtracted from m and the result recorded as the crack length.

9. Analysis of Experimental Data

9.1 Assessment of Force/Clip Gage Displacement Records—The applied force-displacement record obtained from a fracture test on a notched specimen will usually be one of the five types shown in Fig. 1.

9.1.1 In the case of a smooth continuous record in which the applied force rises with increasing displacement up to the onset of unstable brittle crack extension or pop-in, and where no significant slow stable crack growth has occurred (see 3.2 and Fig. 1a and Fig. 1b), the critical CTOD, δ_c shall be determined from the force and plastic component of clip gage displacement, v_p , corresponding to the points P_c and v_c . If failure occurs close to the linear range, apply the procedure of Test Method E 399 to test whether a valid K_{Ic} measurement can be made.

9.1.2 In the event that significant slow stable crack extension (see 3.2) precedes either unstable brittle crack extension or pop-in, or a maximum force plateau occurs, the force-displacement curves will be of the types shown in Fig. 1c, Fig. 1d, and Fig. 1e, respectively. These figures illustrate the values of P and v to be used in the calculation of δ_u or δ_m , whichever is appropriate.

9.1.3 If the pop-in is attributed to an arrested unstable brittle crack extension in the plane of the fatigue precrack, the result must be considered as a characteristic of the material tested.

NOTE 1—Splits and delaminations can result in pop-ins with no arrested brittle crack extension in the plane of the fatigue precrack.

For this test method, pop-in crack extension in the plane of the fatigue precrack can be assessed by a specific change in compliance. The following procedure may be used to assess the significance of small pop-ins (see 3.2 and Fig. 1b and 1d). Referring to Fig. 1 and Fig. 12, measure the values of P_c and v_c or P_u and v_u from the test record at points corresponding to: (a) the earliest significant pop-in fracture, that is, for which $F \geq 0.05$ and (b) fracture, when pop-ins prior to fracture may be ignored, that is, for which $F < 0.05$ as follows:

E 1290

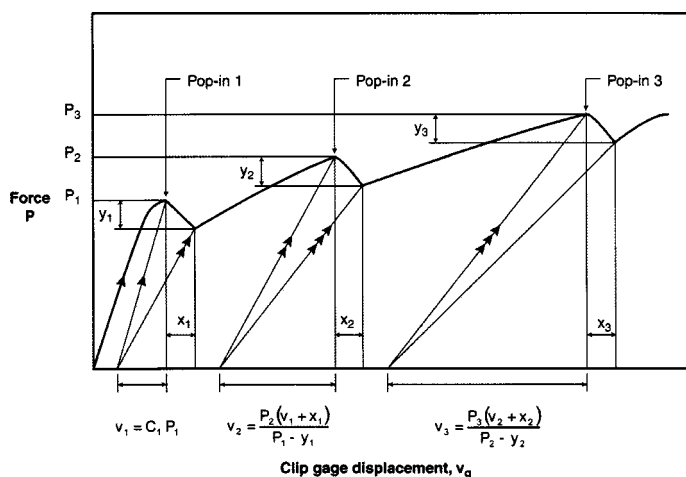

NOTE 1— C_1 is the initial compliance.

NOTE 2—The pop-ins have been exaggerated for clarity.

FIG. 12 Significance of Pop-In

$$F = 1 - \frac{v_1}{P_1} \cdot \left(\frac{P_n - y_n}{v_n + x_n} \right) \quad (5)$$

where:

F = factor representing the accumulated increase in compliance and crack size due to all stable crack extensions, or pop-ins, or both, prior to and including the n^{th} pop-in, and

n = sequential number (see Fig. 12) of the last of the particular series of pop-ins being assessed.

NOTE 2—When only one pop-in occurs, $n = 1$. When multiple pop-ins occur it may be necessary to make successive assessments of F with $n = 1, 2, 3$, or more.

v_j = elastic displacement at pop-in No. 1 (see Fig. 12),

P_n = force at the n^{th} pop-in, and

v_n = elastic displacement at the n^{th} pop-in.

NOTE 3— v_n may be determined graphically or analytically (see Fig. 12).

y_n = force drop at the n^{th} pop-in, and

x_n = displacement increase at the n^{th} pop-in.

NOTE 4—Although an individual pop-in may be ignored on the basis of these criteria, this does not necessarily mean that the lower bound of fracture toughness has been measured. For instance, in an inhomogeneous material such as a weld, a small pop-in may be recorded because of fortuitous positioning of the fatigue precrack tip. Thus, a slightly different fatigue precrack position may give a larger pop-in, which could not be ignored. In such circumstances the specimens should be sectioned after testing, and examined metallographically to ensure that the crack tips have sampled the weld or base metal region of interest (see Ref. (2)).

9.1.4 The initial compliance C_I shall be determined by constructing the tangent OA to the initial portion of the force-clip gage displacement curve as shown in Fig. 13. The initial compliance C_I is the inverse of the slope of the tangent line OA:

$$C_I = \Delta v_g / \Delta P \quad (6)$$

9.2 Methods for Calculation of δ_c , δ_w or δ_m —Having

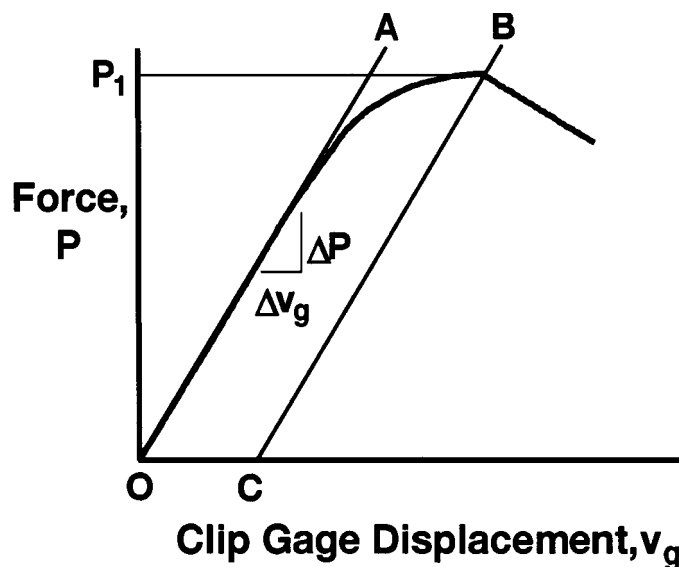

FIG. 13 Determination of Initial Compliance

obtained the required value of the clip gage displacement, it is necessary to convert this to the relevant CTOD using the following relationship for SE(B) and C(T) specimens having $0.45 \leq a_o/W \leq 0.70$ (see 1.1.2, 1.1.3, 7.1.2, and 7.1.3) A(B) and specimens having $0.45 \leq a_o/W \leq 0.55$ (see 1.1.4 and 7.3.2). To calculate δ_c , δ_u or δ_m :

$$\delta = K^2(1 - v^2)/2\sigma_{YS}E + r_p(W - a_o)v_p/[r_p(W - a_o) + a_o + z] \quad (7)$$

where:

$K = YP/[BW^{1/2}]$, and

Y is determined as follows:

(a) SE(B) Specimen having $S = 4W$:

Y

$$= \frac{6(a_o/W)^{1/2} (1.99 - a_o/W[1 - a_o/W][2.15 - 3.93a_o/W + 2.7(a_o/W)^2])}{(1 + 2a_o/W)(1 - a_o/W)^{3/2}} \quad (8)$$

(b) C(T) Specimen:

 **E 1290**

$$Y = \frac{(2 + a_o/W)(0.886 + 4.64a_o/W - 13.32(a_o/W)^2 + 14.72(a_o/W)^3 - 5.6(a_o/W)^4)}{(1 - a_o/W)^{3/2}} \quad (9)$$

(c) A(B) Specimen:

for $S = 4W$,

$$Y = 4 [1 + (1 - r_1/r_2) \cdot h_1(a_o/W)] f_1(a_o/W) \quad (10)$$

for $S = 3W$,

$$Y = 3 [1 + (1 - r_1/r_2) \cdot h_2(a_o/W)] f_2(a_o/W). \quad (11)$$

Values of Y for the SE(B) and C(T) specimens are summarized in Table 1 and Table 2, respectively. Table 3 lists values of h_1 , f_1 , h_2 , and f_2 for the A(B) specimen:

P = force corresponding to P_c , P_u , or P_m , (See Fig. 1),

ν = Poisson's ratio,

σ_{YS} = yield or 0.2 % offset yield strength at the temperature of interest,

E = Young's modulus at the temperature of interest,

v_p = plastic component of clip gage opening displacement corresponding to v_c , v_u or v_m . See Fig. 1,

z = distance of knife edge measurement point from front face (notched surface) on SE(B) specimen, or from load line in C(T) specimen (see 6.4.1), and

r_p = plastic rotation factor = $0.4(1 + \alpha)$.

(d) for SE(B) and A(B) specimens:

$\alpha = 0.1$, and

$r_p = 0.44$.

(e) for C(T) specimens:

$$\alpha = 2\sqrt{[(a_o/b_o)^2 + a_o/b_o + 1/2]} - 2(a_o/b_o + 1/2) \quad (12)$$

and

$$r_p = 0.47 \text{ for } 0.45 \leq a_o/W \leq 0.50, \text{ or} \quad (13)$$

$$r_p = 0.46 \text{ for } 0.50 < a_o/W \leq 0.56, \text{ or} \quad (14)$$

$$r_p = 0.45 \text{ for } 0.56 < a_o/W \leq 0.63, \text{ or} \quad (15)$$

$$r_p = 0.44 \text{ for } 0.63 < a_o/W \leq 0.70 \quad (16)$$

9.3 Discontinued Test—If the test is terminated by some fault in the testing system, or the force-displacement recording exceeds the range of the clip gage or recording chart, report δ as being greater than that concomitant with the last force recorded. In the latter case, report the maximum force as greater than the force recorded at chart run-out.

9.4 Qualifying CTOD Values:

9.4.1 The critical CTOD values, for example, δ_c and δ_u , are valid if:

9.4.1.1 These values of CTOD are equal to or less than the measurement capacity of the specimen, which corresponds to δ_m .

9.4.1.2 The difference between the maximum and minimum of all 9 crack length measurements of the fatigue crack does not exceed 0.10 the original (fatigue) crack length a_o ,

9.4.1.3 No part of the fatigue crack front is closer to the machined notch than the lesser of 0.025 W or 1.3 mm (0.05 in.),

9.4.1.4 The plane of the fatigue crack surface does not exceed an angle of 10° from the plane of the notch, and

9.4.1.5 The fatigue crack front is not multi-planar or branched.

10. Report

10.1 Report the following information for each test:

10.1.1 The specimen configuration.

10.1.2 The crack plane orientation in accordance with appropriate figures in Terminology E 1823.

10.1.3 Specimen test temperature, $^\circ\text{C}$ ($^\circ\text{F}$), and environment.

TABLE 1 Stress Intensity Coefficients (Y) for SE(B) Specimens Having $S/W = 4$

NOTE 1—For rectangular and square section specimens see Figs. 6 and 7.

a/W	0.000	0.001	0.002	0.003	0.004	0.005	0.006	0.007	0.008	0.009
0.45	9.142	9.169	9.196	9.223	9.250	9.278	9.305	9.333	9.361	9.389
0.46	9.417	9.445	9.473	9.502	9.530	9.559	9.588	9.617	9.646	9.675
0.47	9.704	9.734	9.763	9.793	9.823	9.853	9.883	9.913	9.944	9.974
0.48	10.01	10.04	10.07	10.10	10.13	10.16	10.19	10.22	10.26	10.29
0.49	10.32	10.35	10.38	10.42	10.45	10.48	10.52	10.55	10.58	10.62
0.50	10.65	10.68	10.72	10.75	10.79	10.82	10.86	10.89	10.93	10.96
0.51	11.00	11.03	11.07	11.10	11.14	11.18	11.21	11.25	11.29	11.32
0.52	11.36	11.40	11.43	11.47	11.51	11.55	11.59	11.63	11.66	11.70
0.53	11.74	11.78	11.82	11.86	11.90	11.94	11.98	12.02	12.06	12.10
0.54	12.15	12.19	12.23	12.27	12.31	12.35	12.40	12.44	12.48	12.53
0.55	12.57	12.61	12.66	12.70	12.75	12.79	12.84	12.88	12.93	12.97
0.56	13.02	13.06	13.11	13.16	13.20	13.25	13.30	13.35	13.39	13.44
0.57	13.49	13.54	13.59	13.64	13.69	13.74	13.79	13.84	13.89	13.94
0.58	13.99	14.04	14.10	14.15	14.20	14.25	14.31	14.36	14.41	14.47
0.59	14.52	14.58	14.63	14.69	14.74	14.80	14.86	14.91	14.97	15.03
0.60	15.09	15.14	15.20	15.26	15.32	15.38	15.44	15.50	15.56	15.62
0.61	15.69	15.75	15.81	15.87	15.94	16.00	16.06	16.13	16.19	16.26
0.62	16.32	16.39	16.46	16.52	16.59	16.66	16.73	16.80	16.86	16.93
0.63	17.00	17.08	17.15	17.22	17.29	17.36	17.44	17.51	17.58	17.66
0.64	17.73	17.81	17.88	17.96	18.04	18.12	18.19	18.27	18.35	18.43
0.65	18.51	18.59	18.67	18.76	18.84	18.92	19.01	19.09	19.18	19.26
0.66	19.35	19.44	19.52	19.61	19.70	19.79	19.88	19.97	20.06	20.15
0.67	20.25	20.34	20.44	20.53	20.63	20.72	20.82	20.92	21.02	21.12
0.68	21.22	21.32	21.42	21.52	21.63	21.73	21.84	21.94	22.05	22.16
0.69	22.27	22.38	22.49	22.60	22.71	22.82	22.94	23.05	23.17	23.28
0.70	23.40									



TABLE 2 Stress Intensity Coefficients (Y) for C(T) Specimens

a/W	0.000	0.001	0.002	0.003	0.004	0.005	0.006	0.007	0.008	0.009
0.45	8.340	8.363	8.387	8.410	8.434	8.458	8.482	8.506	8.531	8.555
0.46	8.579	8.604	8.629	8.654	8.678	8.704	8.729	8.754	8.779	8.805
0.47	8.830	8.856	8.882	8.908	8.934	8.960	8.987	9.013	9.040	9.066
0.48	9.093	9.120	9.147	9.175	9.202	9.230	9.257	9.285	9.313	9.341
0.49	9.369	9.398	9.426	9.455	9.483	9.512	9.541	9.571	9.600	9.629
0.50	9.659	9.689	9.719	9.749	9.779	9.810	9.840	9.871	9.902	9.933
0.51	9.964	10.00	10.03	10.06	10.09	10.12	10.16	10.19	10.22	10.25
0.52	10.29	10.32	10.35	10.39	10.42	10.45	10.49	10.52	10.56	10.59
0.53	10.63	10.66	10.70	10.73	10.77	10.80	10.84	10.87	10.91	10.95
0.54	10.98	11.02	11.06	11.10	11.13	11.17	11.21	11.25	11.29	11.33
0.55	11.36	11.40	11.44	11.48	11.52	11.56	11.60	11.64	11.68	11.73
0.56	11.77	11.81	11.85	11.89	11.94	11.98	12.02	12.06	12.11	12.15
0.57	12.20	12.24	12.28	12.33	12.37	12.42	12.47	12.51	12.56	12.60
0.58	12.65	12.70	12.75	12.79	12.84	12.89	12.94	12.99	13.04	13.09
0.59	13.14	13.19	13.24	13.29	13.34	13.39	13.44	13.50	13.55	13.60
0.60	13.65	13.71	13.76	13.82	13.87	13.93	13.98	14.04	14.09	14.15
0.61	14.21	14.27	14.32	14.38	14.44	14.50	14.56	14.62	14.68	14.74
0.62	14.80	14.86	14.92	14.99	15.05	15.11	15.18	15.24	15.31	15.37
0.63	15.44	15.50	15.57	15.64	15.70	15.77	15.84	15.91	15.98	16.05
0.64	16.12	16.19	16.26	16.34	16.41	16.48	16.56	16.63	16.71	16.78
0.65	16.86	16.93	17.01	17.09	17.17	17.25	17.33	17.41	17.49	17.57
0.66	17.65	17.73	17.82	17.90	17.99	18.07	18.16	18.25	18.33	18.42
0.67	18.51	18.60	18.69	18.78	18.87	18.97	19.06	19.15	19.25	19.34
0.68	19.44	19.54	19.64	19.74	19.83	19.94	20.04	20.14	20.24	20.35
0.69	20.45	20.56	20.66	20.77	20.88	20.99	21.10	21.21	21.32	21.44
0.70	21.55									

TABLE 3 Stress Intensity Coefficients h_1 , h_2 and f_1 , f_2 for A(B) Specimens

a/W	$h_1(a/W)$	$f_1(a/W)$	$h_2(a/W)$	$f_2(a/W)$
0.450	0.0679	2.29	0.0803	2.23
0.455	0.0663	2.32	0.0792	2.26
0.460	0.0647	2.36	0.0782	2.29
0.465	0.0631	2.39	0.0771	2.33
0.470	0.0615	2.43	0.0761	2.36
0.475	0.0600	2.47	0.0751	2.40
0.480	0.0584	2.50	0.0740	2.44
0.485	0.0569	2.54	0.0730	2.48
0.490	0.0554	2.58	0.0720	2.52
0.495	0.0540	2.62	0.0710	2.55
0.500	0.0525	2.66	0.0700	2.60
0.505	0.0511	2.71	0.0690	2.64
0.510	0.0496	2.75	0.0680	2.68
0.515	0.0482	2.80	0.0670	2.72
0.520	0.0468	2.84	0.0660	2.77
0.525	0.0455	2.89	0.0651	2.82
0.530	0.0441	2.94	0.0641	2.86
0.535	0.0428	2.99	0.0631	2.91
0.540	0.0415	3.04	0.0622	2.96
0.545	0.0402	3.09	0.0612	3.01
0.550	0.0389	3.14	0.0603	3.06

10.1.4 The crosshead displacement rate for testing systems in which the rate of change of crosshead displacement can be set, mm/min (in./min).

10.1.5 The time to reach the force P_f , min.

10.1.6 Material yield strength and tensile strength at room temperature.

10.1.7 Material yield strength and tensile strength at the temperature corresponding to the CTOD test conditions.

10.1.8 CTOD, δ_c , δ_u , or δ_m , mm (in.), as appropriate, to an accuracy of two significant figures.

10.1.9 Specimen thickness B , mm (in.).

10.1.10 Specimen width W , mm (in.).

10.1.11 SE(B) and A(B) specimen load span S , mm (in.).

10.1.12 Specimen initial uncracked ligament size b_o , mm (in.).

10.1.13 Distance of clip gage away from SE(B) surface or from C(T) load line, z , mm (in.).

10.1.14 Crack length a_o , mm (in.), and, if applicable, Δa_p , mm (in.).

10.1.15 Force-displacement record.

10.1.15.1 The appropriate plastic component v_p of the clip gage opening displacement v_c , v_u , or v_m , mm (in.).

10.1.15.2 The appropriate applied force P_c , P_u , or P_m , N (lbf).

10.1.16 Fatigue precracking parameters and observations.

10.1.16.1 Range of stress intensity factor, ΔK , for the final portion of precrack growth, MPa-m (ksi-in.).

10.1.16.2 The temperature of the specimen during precracking, °C (°F).

10.1.16.3 The force ratio, $R = P_{\min}/P_{\max}$.

10.1.16.4 Details of any pop-in that may have been ignored in accordance with the assessment procedure in 9.1.3.

11. Precision and Bias

11.1 Precision:

11.1.1 This practice contains four indices of fracture toughness, each of which derives variability from unique sources. Materials tested at upper shelf temperatures are characterized by δ_m for the onset of a maximum force plateau. The CTOD at maximum force, δ_m , can be sensitive to the quality of the autographic equipment used, especially the responsiveness to small changes in force or displacement, or both. The selection of the point of first onset of a maximum force plateau can be somewhat subjective and is a significant problem with very ductile materials that show extensive displacement approaching the maximum force.

11.1.2 The CTOD toughness of ferritic materials tested in the transition temperature range is characterized in this method by δ_c or δ_u . Subtle differences in constraint from geometry

 **E 1290**

differences can promote inconsistency. Also in the mid-transition, data inconsistency, even among specimens of identical dimensions, is commonly encountered. This method recommends testing practices and specimen geometries that affect reasonable control over variability in CTOD outcome. Laboratories should replicate tests in order to assess the effects of variability on CTOD values.

11.1.3 An interlaboratory test program involving eleven laboratories was conducted to assess: (a) the measurement precision of the estimation of specific values of CTOD, and (b) the correlation between rectangular section SE(B) and C(T) specimens. CTOD fracture toughness was estimated for two materials at: (a) initiation of stable crack extension, (b) initiation of unstable crack extension, or (c) the onset of a maximum force plateau. The participants used either single-specimen unloading compliance, electric potential drop, or multiple-specimen heat tinting to estimate the CTOD at initiation of crack extension.⁴

11.2 *Bias*:

⁴ Data on the round robin results are on file at ASTM Headquarters. Request RR: E-24-1013.

11.2.1 Bias suggests a consistent difference from a standard value or set of standard values. There are no “standard” CTOD values for any material. However, bias due to geometry variations can be expected in CTOD values for a particular material. In particular, specimen size and/or remaining ligament size are known to affect the CTOD transition temperature behavior in ferritic steels. Thicker specimens of a given material are expected to have a higher transition temperature. Also, for upper shelf behavior, the value of δ_m can be expected to be larger in specimens of larger plan view size or in specimens of larger remaining ligament size.

11.2.2 Differences in CTOD values for a given specimen thickness and test temperature have been observed between SE(B) and C(T) specimens. However, the present test method attempts to minimize such differences.

11.2.3 Finally, it should be noted that the plastic rotation factor r_p is not a constant factor. The parameter r_p is a complex function of specimen configuration and size, applied loading and material. The values of r_p used in this test method are slightly larger than those in other CTOD test methods (3, 4). The values in this test method are based on an examination of published experimental data (see Refs 5-7), and rigid plastic slip line field analyses (8, 9).

REFERENCES

- (1) Underwood, J. H., “Proposed Standard Arc-Bend Chord-Support Fracture Toughness and K Expressions,” *Journal of Testing and Evaluation*, Vol 17, No. 4, July 1989, pp. 230-233.
- (2) H. G. Pisarski, “Measurement of Heat Affected Zone Fracture Toughness,” Paper TS31, pp. 647–656, Steel in Marine Structures, C. Noordhoek and J. de Back, eds. Proceedings of 3rd International ECSC Conference, Delft, June 15–18, 1987. Elsevier Science Publishers B.V., Amsterdam, 1987.
- (3) BS 7448: Part 1: 1991, “Fracture Mechanics Toughness Tests, Part 1, Method for Determination of K_{IC} , critical CTOD and Critical J Values of Metallic Materials,” The British Standards Institution, 1991.
- (4) AS 2205.7.3, “Crack Opening Displacement (COD) Test,” Standards Association of Australia, 1983.
- (5) Lin, I. H., Anderson, T. L., DeWit, R., and Dawes, M. G., “Displacements and Rotational Factors in Single Edge Notched Bend Specimens,” *Int. Journal of Fracture*, Vol 20, 1982, pp. R3–R7.
- (6) Shang-Xian, Wu, “Plastic Rotational Factor and J-COD Relationship of Three-Point Bend Specimen,” *Engineering Fracture Mechanics*, Vol 18, No. 1, 1983, pp. 83–95.
- (7) Hellmann, D., and Schwalbe, K-H., “On the Experimental Determination of CTOD Based R-Curves,” *The Crack Tip Opening Displacement in Elastic Plastic Fracture Mechanics*, Ed., K-H. Schwalbe, Springer-Verlag Berlin, Heidelberg, 1986, pp. 115–132.
- (8) Matsoukas, G., Cotterell, B., and Mai, Y-W., “On the Plastic Rotation Constant Used in Standard COD Tests, AWRA Document P4-5A-84, AWRA Contract 93,” Australian Welding Research, December 1984, pp. 50–51.
- (9) Wu, Shang-Xian, Mai, Y-W., and Cotterell, B., “Slip Line Field Solutions of Three-Point Bend Specimens with Deep Notches, AWRA Document P2-57-86, AWRA Contract 93,” Australian Welding Research, December 1986, pp. 32–36.

The American Society for Testing and Materials takes no position respecting the validity of any patent rights asserted in connection with any item mentioned in this standard. Users of this standard are expressly advised that determination of the validity of any such patent rights, and the risk of infringement of such rights, are entirely their own responsibility.

This standard is subject to revision at any time by the responsible technical committee and must be reviewed every five years and if not revised, either reapproved or withdrawn. Your comments are invited either for revision of this standard or for additional standards and should be addressed to ASTM Headquarters. Your comments will receive careful consideration at a meeting of the responsible technical committee, which you may attend. If you feel that your comments have not received a fair hearing you should make your views known to the ASTM Committee on Standards, 100 Barr Harbor Drive, West Conshohocken, PA 19428.

This standard is copyrighted by ASTM, 100 Barr Harbor Drive, West Conshohocken, PA 19428-2959, United States. Individual reprints (single or multiple copies) of this standard may be obtained by contacting ASTM at the above address or at 610-832-9585 (phone), 610-832-9555 (fax), or service@astm.org (e-mail); or through the ASTM website (<http://www.astm.org>).